

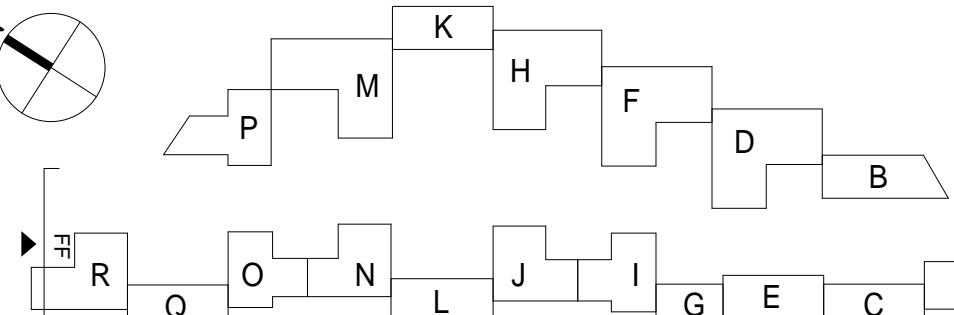

KEY PLAN



REV	DATE	DESCRIPTION
P1	15.02.19	Planning board for Information
P2	17.05.19	GLA Planning Askandum

**NOTES**  
 Check and verify all dimensions prior to commencement of work.  
 This drawing shall be read in conjunction with all other contract documents including those by other consultants, and including specifications.  
 Seek clarification of inconsistencies/ conflicts.  
 Figured dimensions shall take precedence to scaled dimensions.

DRAWN	CHECKED	JOB NO.
Author	Checker	44032

This drawing is COPYRIGHT and shall remain the property of  
**ARNEY FENDER KATSALIDIS**

**CLIENT**  
 Meadow Residential

**PROJECT**  
 Mill Hill - London

**ARCHITECTS**  
 AFK ARCHITECTURE + INTERIORS  
 44-46 SCRUTTON STREET LEVEL 1  
 LONDON, EC2A-4HH, UNITED KINGDOM.  
 CLIENT:  
 MEADOW RESIDENTIAL  
 FIRST FLOOR 51 GREAT  
 MARLBOROUGH STREET, LONDON,  
 W1F 7JZ.

**DRAWING TITLE**  
 SECTION FF

**STRUCTURAL ENGINEER:**  
 FTS  
 FEAR TREE COURT,  
 LONDON,  
 EC1N 8DS.  
**MECHANICAL / ELECTRICAL ENGINEER:** CHAPMAN BOSP  
 SAFFRON HOUSE, 5-11 KIRBY STREET,  
 LONDON, EC1N 8TS.

**LANDSCAPE ARCHITECT:**  
 OUTERSIDGE  
 THE BOATHOUSE 27 FERRY  
 ROAD, TEDDINGTON, TW11 9NN.

**Arney Fender Katsalidis**

**SCALE**  
 1 : 100 @ A1

**REVISION / DRAWING No.**  
 P2 | PLANNING

A25-10-03