

SECTION AA

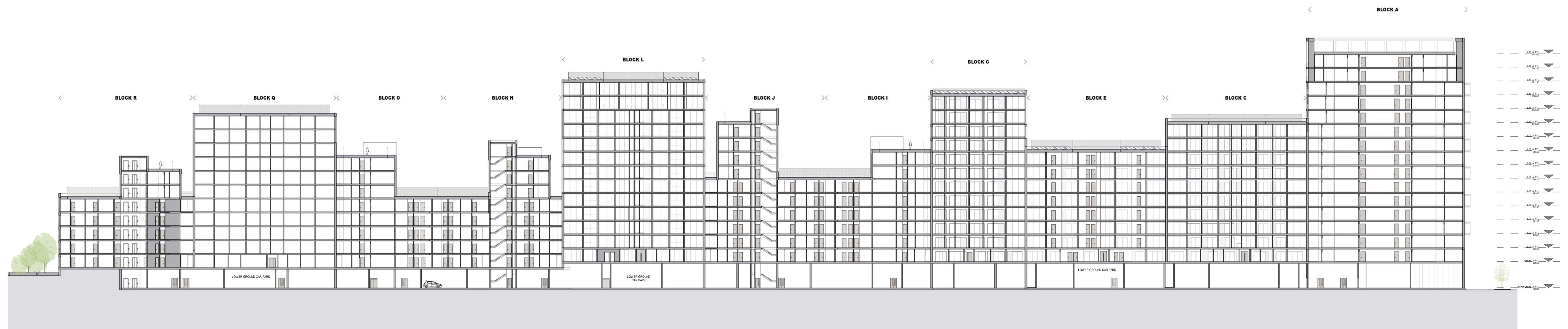

SECTION BB



SECTION CC

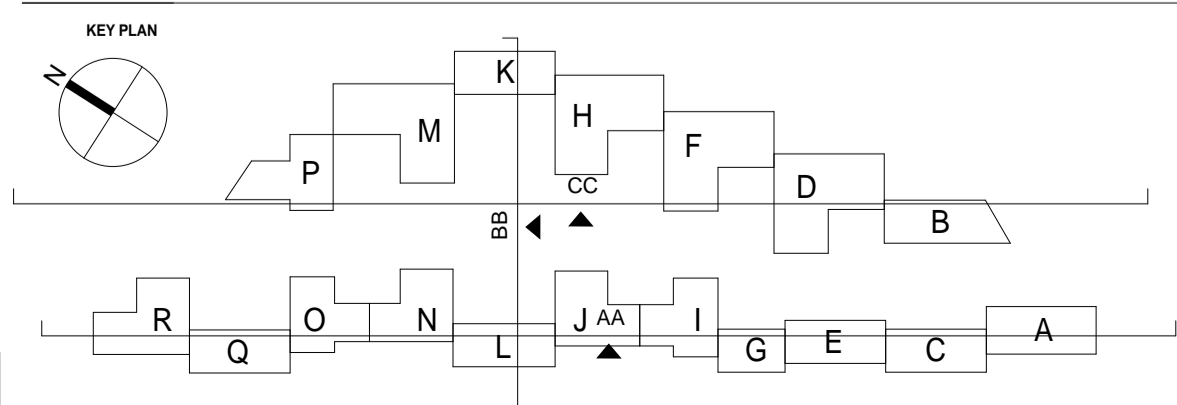

REV	DATE	DESCRIPTION
P1	15.02.19	Planning board for Information
P2	17.05.19	GLA Planning Addendum

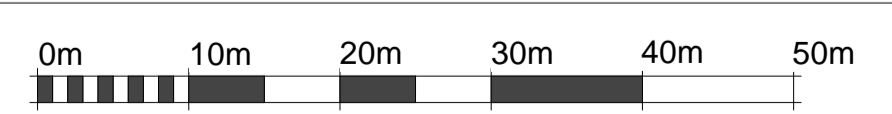

**NOTES**  
 Check and verify all dimensions prior to commencement of work.  
 This drawing shall be read in conjunction with all other contract documents including those by other consultants, and including specifications.  
 Seek clarification of inconsistencies/ conflicts.  
 Figured dimensions shall take precedence to scaled dimensions.

DRAWN	CHECKED	JOB NO.
PA	JC	44032

This drawing is COPYRIGHT and shall remain the property of  
**ARNEY FENDER KATSALIDIS**

**CLIENT**  
 Meadow Residential

**PROJECT**  
 Mill Hill - London

**ARCHITECTS:**  
 AFK ARCHITECTURE + INTERIORS  
 44-46 SCRUTTON STREET LEVEL 1  
 LONDON, EC2A-4HH, UNITED KINGDOM.  
**CLIENT:**  
 MEADOW RESIDENTIAL  
 FIRST FLOOR, 51 GREAT  
 MARLBOROUGH STREET, LONDON,  
 W1F 7JZ.

**STRUCTURAL ENGINEER:**  
 FTS  
 FERRAR TREE COURT,  
 LONDON,  
 EC1N 8JG.  
**MECHANICAL / ELECTRICAL ENGINEER:** CHAPMAN BOSS  
 SAFRON HOUSE, 5-11 KIRBY STREET,  
 LONDON, EC1N 8TS.

**LANDSCAPE ARCHITECT:**  
 THE BATHHOUSE, 27 FERRY  
 ROAD, TEDDINGTON, TW11 9NN.

**DRAWING TITLE**  
 SECTION AA / BB / CC

**Arney Fender Katsalidis**

**SCALE**  
 1:500@A1

**REVISION / DRAWING No.**  
 P2 | PLANNING

A25-00-01