

GREATER**LONDON**AUTHORITY

**London's Zero Carbon Energy
Resource:
Secondary Heat
Report Phase 2**

April 2013

Secondary Heat study Phase 2: Network and System impacts

Copyright

Greater London Authority

March 2013

Greater London Authority

City Hall

The Queen's Walk

More London

London SE1 2AA

www.london.gov.uk

enquiries 020 7983 4100

minicom 020 7983 4458

Team

The Greater London Authority

Peter North

Ross Hudson

Buro Happold Ltd

Alasdair Young

Henrietta Cooke

Chris Grainger

DEC Engineering Ltd, Canada

Erik Lindquist

COWI, Denmark

Poul Weiss

This report has been led by Buro Happold Ltd, working in collaboration with the Greater London Authority and supported by DEC Engineering, Canada, and COWI, Denmark.

Secondary Heat study Phase 2: Network and System impacts

Revision	Description	Issued by	Date	Checked
00	Draft for comment	AY	08/03/13	GS
01	Final	HC	04/04/13	AY

report collation **Henrietta Cooke**

signature



date 04/04/13

report checking **Alasdair Young**

signature



date 04/04/13

report approval **Andy Keelin**

signature



date 04/04/13

GLA approval **Ross Hudson**

signature

date

Executive summary

The Greater London Authority (GLA) has commissioned a study into the capacity and utilisation of secondary heat sources in London. For the purposes of this study, secondary heat is considered to be heat arising as a by-product of industrial and commercial activities, from infrastructure operation, and from the environment (air, ground, water).

This study builds on the *Mayor's Decentralised Energy Capacity Study* (2011)¹ which suggests that by 2030 22% of London's heat and electrical energy could be generated by decentralised energy sources linked to heat networks. Sources of this heat are likely to be combustion of primary fuel sources including gas, biomass and waste. With the likely reduction in availability and viability of gas, and possibly waste, there will be an increasing emphasis on alternative sources, of which secondary heat is one. Further to this as gas fired combined heat and power ceases to be a low carbon option from around 2030 zero carbon heat sources are required to ensure heat networks do not become a stranded asset.

In the first phase of this study the London wide potential for secondary heat sources was addressed. The objectives of this report are to provide an understanding of the impacts on buildings and heat networks of utilising these secondary sources of heat via low temperature heat networks. This report also addresses the cost and environmental benefits of each heat source and explores emerging spatial and project opportunities for using secondary heat.

Carbon Intensity

For most secondary heat sources it is necessary to upgrade the temperature of available heat to be usable directly within district heating systems – this requires the use of heat pumps. The carbon intensity of secondary heat is therefore directly related to the carbon intensity of the electricity supply driving the heat pumps in these cases. Section 2 explores the cost and carbon intensity of heat from secondary sources.

Using heat networks allows the use of larger scale heat pumps, operating with higher heat input temperatures. Both of these factors significantly improve the efficiency of heat pumps (modelled as co-efficient of performance). Heat pump efficiency increases by around 80% when input temperatures increase from 5°C to 35°C. The operating temperature of heat networks is also very important. For example heat pumps supplying heat at 55°C are around 25% more efficient than heat pumps supplying heat at 70°C.

Future projections of carbon factors consider the decarbonisation of the electricity grid network and as such, heat pumps connected to secondary sources can deliver heat at 70°C and still offer significant carbon savings. For 2030 and 2050 scenarios the heat carbon intensity is below 0.05tCO₂/MWh, four times less than the equivalent heat from large gas boilers and in for most sources it is much lower than this. The carbon intensity is lower than individual air source heat pumps in all cases.

¹ GLA (2011) Decentralised Energy Capacity Study: <http://www.london.gov.uk/priorities/environment/climate-change/decentralised-energy>

Cost

Approximately one third of the secondary heat sources explored in this study have a lower levelised cost than that of the counterfactual gas boiler case at current prices. Viable sources include heat recovery from supermarkets, power stations, national grid substations and data centres. Sources more expensive than the counterfactual case are dominated by the environmental sources such as air and river. As with carbon, the cost of heat from secondary heat sources is linked to the need to upgrade their temperature for effective use. Future costs associated with the use of these sources are highly dependent on electricity prices, but less so than individual heat pumps due to their higher efficiency. The opportunity to use heat pumps connected to heat networks also increases their utilisation (or run hours or load factor) which significantly reduces the cost of heat.

In the short term secondary heat system projects should focus on recovering heat at the highest possible temperatures, including heat from industry and existing gas engine generators. These sources also provide the lowest cost of heat and can often be used directly.

Building connections and performance

The lowest practical temperature for connecting to heat networks without heat pumps is approximately 55°C. A number of generic building types were modelled (see Section 3) to explore the implications of connecting to lower temperature networks. For the buildings modelled, a flow temperature of 55°C could be used to supply at least 70% of the total heating load in residential buildings and more in non-residential buildings. In most cases modest improvements in energy efficiency, equivalent to an increase in one Energy Performance Certificate (EPC) band, could enable almost 100% of heating demand to be met from flow temperatures of 55°C or above. Practical applications decrease significantly below 55°C - heat supply temperatures of 40°C can only supply a minority of annual heat demand, even with extensive retrofit. They cannot supply domestic hot water. Only electrical transformer and industrial sources are considered available at or above 55 °C meaning heat pumps are required for all other sources.

System design

Using secondary heat sources requires the use of low temperature heat networks to maximise carbon savings and minimise the cost of heat. The focus of system design should be on ensuring low return temperatures to the district network. This is key to enabling the use of low temperature secondary heat and building heating systems must be designed to comply with best practice guidelines to ensure this. This is particular true during relatively low load conditions which constitute the majority of operating conditions. Incentives to ensure can be included in heat tariffs. Specific recommendations for system designers are included in Section 4 of this report.

Systems can be designed to integrate a low temperature heat source into a high temperature network however the heat is usually upgraded (using heat pumps) to the same temperature at which the network is running. Control of systems with multiple input temperatures is difficult for small systems, though can be managed with careful design. For larger systems with more stable operating conditions the use of multiple temperatures is possible, though operating the entire system at a lower temperature may be preferable, raising temperature only during peak load conditions. Use of twin pipe and plastic pipes can help to reduce heat loss and costs for low temperature systems. Section 5 explores the impact of secondary heat sources on heat network operation.

Emerging opportunities

Based on the modelling of supply and demand of secondary heat undertaken in Phase 1 of this study, five potential opportunities around London have been identified in Section 6 of this report. These areas exhibit varied characteristics in terms of available secondary heat and demand for heat from low temperature networks. They were identified on the basis of the following factors: the availability of multiple secondary heat sources; the presence of high density heat demand area making heat networks more viable; location close of existing or planned heat networks, and; the available secondary heat sources being able to meet the majority of heat demand within an area.

From these opportunities Barking and the Royal Docks has been selected as a pilot area to understand the technical and economic viability of such a system. This could be further extended to Canary Wharf with the additional benefit of capturing waste heat from the large commercial buildings located there. The secondary heat supply in the pilot study area is extensive and can easily match the demand in the area. Modelling suggests that multiple heat sources are required, with peak load provided by conventional heat sources to provide backup and resilience. The sources are cost competitive with gas boilers for the provision of heat via heat networks. This assumes that a heat network already exists in the area.

The demand in this area can be met by secondary sources with carbon intensities significantly lower than that of the counterfactual (gas boilers) case under 2010 energy prices (a 'Business as Usual' scenario). Under this scenario eleven sources have lower levelised costs than the counterfactual case and these represent 92% of the predicted secondary heat demand in the pilot study area. Gas boilers have been included in the recommended system design to allow for peak lopping and to increase the flow temperature above 70°C during peak demand conditions. The number and diversity of sources can be reduced by including thermal storage in the system. Diurnal storage is considered most appropriate in practice as seasonal storage is likely to be expensive. The relative abundance of secondary heat in the area limits the usefulness of seasonal storage.

The opportunity for sharing heating and cooling between buildings is explored in Section 6 using ambient temperature district networks within the pilot area. Significant reductions in energy use are possible through this technology, along with potentially much lower network costs.

Further work

This phase of the study has identified a number of areas of further work which should be undertaken. This includes a capital and whole life cost comparison between a low temperature and a conventional temperature district heating system. Technical issues include a more detailed review of network sizing for low temperature systems, particularly in comparison to requirements for a conventional district heating system. This will influence the ability to switch a conventional heat network to lower temperature operation in future. To further develop the pilot area data collection on the heating systems and heat emitter types for any buildings considered for connection to a low temperature heat network is required. This data would also better inform the opportunities for using low temperature heat in London as the modelling undertaken has been limited to a few generic building types. To understand the minimum operating temperature for heat networks engagement with public health authorities on the issue of Legionella is required.

Contents

Executive summary	i	
1	Introduction	7
	1.1 Background	7
	1.2 Study Objectives	7
	1.3 Overall methodology	8
	1.4 Key research questions	9
2	Heat capture	11
	2.1 Overview	11
	2.2 Heat Pump Analysis	11
	2.3 Cost and Carbon Intensity Analysis	13
	2.4 Conclusions	20
3	Heat connections: buildings	22
	3.1 Overview	22
	3.2 Building heating systems	22
	3.3 Building performance	25
	3.4 Conclusions	38
4	Heat connections: secondary side systems	40
	4.1 Overview	40
	4.2 Approaches for secondary system design	41
	4.3 Case study examples of recent practice	48
	4.4 Conclusions on heat network connections	52
5	System operation	53
	5.1 Overview	53
	5.2 Connection to higher temperature networks	53
	5.3 Benefits of using lower temperature sources of heat	55
	5.4 Temperature Variation	57
	5.5 Changing from one temperature to another	58
	5.6 Impacts on connected building systems	59
	5.7 Conclusions	60
6	Emerging opportunities and pilot study	62
	6.1 Overview	62

Secondary Heat study Phase 2: Network and System impacts

6.2	Emerging opportunities	62
6.3	Pilot study area	66
6.4	Results and discussion	71
6.5	Conclusions	79
7	Employment and Investment Opportunities	80
8	Further work	81
8.1	Heat supply	81
8.2	Connections	81
8.3	System operation	81
8.4	Emerging areas and pilot study area	82
	APPENDIX A – Scenarios	83
	APPENDIX B – Heat source Infrastructure Costs	84
	APPENDIX C – Marginal cost of heat curves	85
	APPENDIX D – Comments on Poyry Heat Pump Technical Assessment	87
	APPENDIX E – Comparison of ambient temperature energy sharing networks	90
	APPENDIX F – Pilot study district energy sharing system	93
	APPENDIX G – DESS Loads and Sources Maps	106
	APPENDIX H – DESS Concept Schematic	108

Table of tables

Table 2-1 – Data for scenario modelling	14
Table 2-2 – Levelised costs of each secondary heat source under the 2010 BAU scenario	16
Table 3-1 – District heating temperatures modelled in building heat performance calculations	26
Table 3-2 – Proportion of annual heat demand which can be met by heat source temperature for radiators sized to meet peak demand at base case flow and return temperatures – residential	32
Table 3-3 - Proportion of annual heat demand which can be met by heat source temperature for radiators sized to meet peak demand at base case flow and return temperatures – non-residential	32
Table 3-4 – Percentage of annual heat demand which can be met for a given fabric efficiency after retrofit – supply temperature 70/50 °C (LT Type A heat network) – residential	34
Table 3-5 – Percentage of annual heat demand which can be met for a given fabric efficiency after retrofit – supply temperature 55/35 °C (LT Type B heat network) – residential	34
Table 3-6 – Percentage of annual heat demand which can be met for a given fabric efficiency after retrofit – supply temperature 40/20 °C (LT Type C heat network) – residential	34
Table 3-7 – Percentage of annual heat demand which can be met for a given fabric efficiency after retrofit – supply temperature 70/50 °C (LT Type A heat network) – non-residential	35
Table 3-8 – Percentage of annual heat demand which can be met for a given fabric efficiency after retrofit – supply temperature 55/35 °C (LT Type B heat network) – non-residential	35
Table 3-9 – Percentage of annual heat demand which can be met for a given fabric efficiency after retrofit – supply temperature 40/20 °C (LT Type C heat network) – non-residential	35
Table 4-1 – Recommendations for design of building heating systems for connections to low temperature heat networks	42
Table 4-2 – Recommendations for design of building heating systems for connections to low temperature heat networks	45
Table 6-1 – Shortlisting criteria for emerging opportunities for low temperature heat networks	63
Table 6-2 – Pilot study supply sources	68
Table 6-3 – Heat demand suited to 70°C heat network	70
Table 6-4 – Additional heat supply sources for the pilot study area	71
Table 6-5 – Summary of DESS capacity and supply in each sub-section	78

Table of figures

Figure 1-1 – Schematic indicating primary system elements to be reviewed.....	8
Figure 2-1 – Heat pump COPs by evaporator (source) temperature for four different heat output (condenser) temperatures (500-1000kW scale heat output)	12
Figure 2-2 – Outline methodology for heat capture section	13
Figure 2-3 – Heat supply marginal abatement cost curve BAU 2010. The counterfactual levelised cost is indicated by the grey line.....	16
Figure 2-4 – Carbon intensity of heat supply sources by scenario.....	17
Figure 2-5 –Carbon intensity v levelised cost of secondary heat sources in London (BAU 2010)	18
Figure 2-6 – Carbon intensity v levelised cost of secondary heat sources in London (Co-ordinated 2050)	19
Figure 2-7 – Levelised heat generation costs at the point of generation for all scenarios.....	20
Figure 3-1 – Approach to analysis of issues associated with heat connections within buildings	22
Figure 3-2 – Danish heat network temperatures in new buildings for domestic hot water supply..	25
Figure 3-3 – District heating mean temperature vs heat output factor for radiator system peak load. The blue line highlights the mean temperature and corresponding output factor for flow/return temperatures of 82/71°C; the red line highlights the equivalent for 70/50°C; the green line for 50/35°C; and the purple line for 40/20°C. The colours correspond to those used in figures 3-5 to 3-8 for the same flow and return temperatures.....	28
Figure 3-4 – Heat output vs flow temperature for a typical underfloor heating system with tiled finish	29
Figure 3-5 – Annual heat demand percentage met by heat supply temperatures – residential high build quality.....	29
Figure 3-6 – Annual heat demand percentage met by heat supply temperatures – residential low build quality.....	30
Figure 3-7 – Annual heat demand percentage met by heat supply temperatures – non-residential high build quality.....	30
Figure 3-8 – Annual heat demand percentage met by heat supply temperatures –non- residential low build quality.....	31
Figure 3-9 – Impact on load duration curve of upgrading the fabric of a poor quality building by one rating (orange line) and by two ratings (grey line) - residential.....	36
Figure 3-10 – Impact on load duration curve of upgrading the fabric of a poor quality building by one rating (orange line) and by two ratings (grey line) – non-residential	37
Figure 4-1 – Principle of two port control for terminal devices.....	41

Secondary Heat study Phase 2: Network and System impacts

Figure 4-2 – Principle of recommended approach for secondary side heating system design to minimise heat network return temperatures	44
Figure 4-3 - Example of use of low loss header with primary pump circuit.....	48
Figure 4-4 – Example of use of 3-port control to bypass heat load and increase return temperatures	49
Figure 4-5 – Example of use of three port control along with a low loss header	50
Figure 5-1 – Use of twin pipe system to limit heat losses.....	56
Figure 6-1 – Emerging opportunities for low temperature heat networks.....	63
Figure 6-2 – Pilot area low temperature heat sources.....	69
Figure 6-3 – Annual heat demand profile showing loads not met by a 70 °C heat supply.....	69
Figure 6-4 – Pilot study heat supply cost curve (BAU 2010)	71
Figure 6-5 – Carbon intensity v levelised cost of secondary heat sources within the Pilot Study area (BAU 2010).....	72
Figure 6-6 – Pilot study area energy balance.....	73
Figure 6-7 – Heat production graphic for typical winter week.....	73
Figure 6-8 – Duration curve for pilot study heat supply	74
Figure 6-9 – Principles of thermal storage	75
Figure 6-10 – Pilot study network map.....	76
Figure 6-11 – Illustration of a District Energy Sharing System (DESS) showing interconnection between sources, loads and transfer stations (source: DEC Engineering, Canada).....	77
Figure 6-12 – Map showing potential location of two DESS sub-sections within the pilot study area, Canary Wharf towards the west and Royal Docks in the centre/east.	78
Figure 7-1 –Investment potential by supply source.....	80

Abbreviations

ASHP	Air source heat pumps
CLG	Department for Communities and Local Government
CHP	Combined heat and power
CHPQA	Combined Heat and Power Quality Assurance
CO ₂	Carbon dioxide
COP	Coefficient of Performance
DE	Decentralised energy
DECC	Department for Energy and Climate Change
Defra	Department for the Environment, Food and Rural Affairs
DESS	District Energy Sharing System
DHW	Domestic Hot Water
EA	Environment Agency
EfW	Energy from waste
EPC	Energy Performance Certificate
GIS	Geographical Information System
GLA	Greater London Authority
GSHP	Ground source heat pump
GWh	Gigawatt hour
LCBP	Low Carbon Buildings Programme
LUL	London Underground Ltd
MSOA	Middle Super Output Area
MW	Megawatt
MWe	Megawatt electric
MWth	Megawatt thermal
MWh	Megawatt hour
SAP	Standard Assessment Procedure
SER	Seasonal Efficiency Rating
SCADA	Supervisory control and data acquisition
SWH	Solar water heating
TfL	Transport for London
UKPN	UK Power Networks
WWTP	Waste Water Treatment Plant

1 Introduction

1.1 Background

The Greater London Authority (GLA) has commissioned a study into the capacity and utilisation of secondary heat sources in London. For the purposes of this study, secondary heat is considered to be heat arising as a by-product of industrial and commercial activities, from infrastructure operation, and from the environment (air, ground, water).

This study builds on the *Mayor's Decentralised Energy Capacity Study (2011)*² which suggests that 22% of London's heat and electrical energy could be distributed by district heating networks by 2030. Sources of this heat are forecast to be via combustion of primary fuel sources including gas, biomass and waste. With the likely reduction in availability and viability of gas and waste, there will be an increasing emphasis on alternative sources, of which secondary heat is one.

This study is being undertaken by Buro Happold in conjunction with specialist consultants DEC Engineering in Canada and COWI in Denmark. It is being overseen by a Steering Group from within the GLA with further input provided by an Advisory Panel, established to help steer the project, particularly in relation to data gathering and interpretation.

1.2 Study Objectives

This Phase 2 report is the final draft of the second report delivered for the project. The Phase 1 report provided a city wide view of the origin, quantum and spatial distribution of sources of secondary heat in London. The key thermodynamic and temporal (diurnal, seasonal) characteristics of each heat source were described. The potential for utilisation of secondary heat sources was quantified by dis-aggregating heat demand into components suitable for supply by low temperature heat within specific areas known as Middle Layer Super Output Areas (MSOA)³.

This report takes a more detailed approach to the analysis in order to examine factors that could influence the connection of secondary heat sources into new and / or existing heat networks.

Objectives of this report are:

1. To provide an understanding of the impacts on network and energy systems of utilising these secondary sources of heat. For the purposes of this study, 'network and energy systems' is set out in Section 1.3.
2. To provide an understanding of the cost and environmental benefits of each heat source in the context of meeting London's heat demand
3. To explore emerging spatial and project opportunities
4. To understand the implications of development of low temperature heat networks for investment and employment

² GLA (2011) Decentralised Energy Capacity Study: <http://www.london.gov.uk/priorities/environment/climate-change/decentralised-energy>

³ An MSOA is a geographical area based on a population of around 7,000 defined to enable consistent reporting of statistics

1.3 Overall methodology

For the purposes of this study, network system elements have been categorised as capture, distribution, connection and overall system operation (Figure 1-1). In general the study assumes that low temperature sources are connected to networks that already exist and does not therefore seek to understand economics of distribution except in cases where additional pipe work may be required to connect remote sources or a new network is required to deal with particularly low temperatures.

- **Capture** refers to the plant and retrofit measures required at the heat source to capture low grade heat and deliver it at a suitable temperature to a district heating network. For conventional temperature connections the heat can be either upgraded at source and delivered at a higher temperature or delivered at a low temperature and upgraded close to the point of end use.
- **Distribution** refers to the underground pipe work that forms the district heating network and transfers the heat from source to point of connection for end use. This element of the overall system is not covered in depth in this study.
- **Connection** refers to the plant and possible retrofit measures required at the point of use to enable the use of low temperature sources of heat.
- **System operation** refers to the management and control of the network system enabling supply of heat at appropriate and usable temperatures to end users.

Detailed methodologies are included in the relevant chapters.

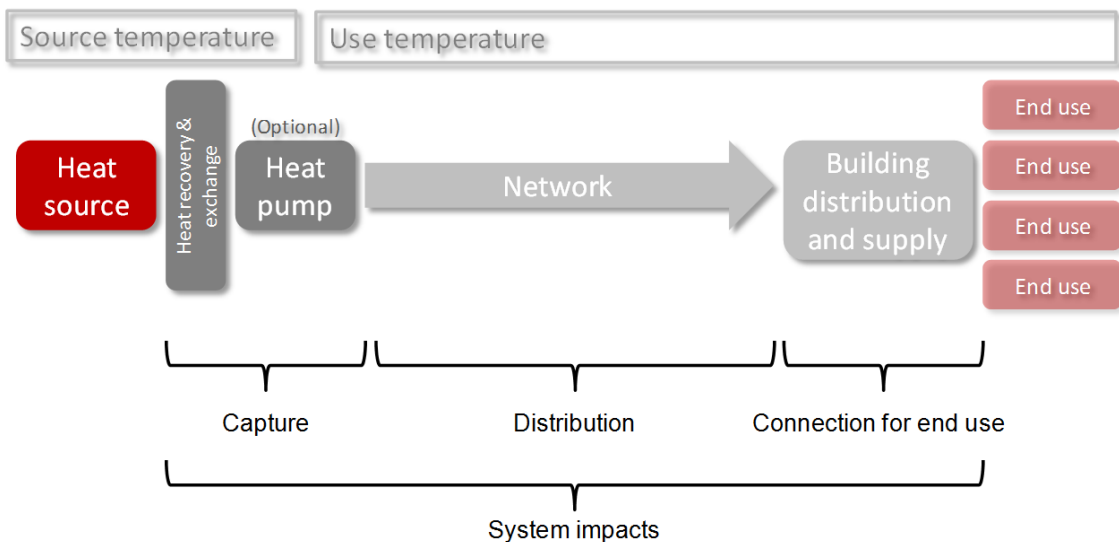

Figure 1-1 – Schematic indicating primary system elements to be reviewed.

1.4 Key research questions

The report aims to address the objectives by answering the following key questions:

System elements	Question	Section of report	Related objective(s)
Capture	1. How can low temperature sources connect to higher temperature networks a. Can these connections be direct b. Can sources supply heat at different temperatures c. Connection into the return leg of DH pipework from lower temperature sources – is this possible / desirable	3 and 4	1
	2. What is the performance of the secondary heat sources a. Carbon intensity of heat b. £/MWh of heat energy	2	2
	3. Obtain and plot real world performance data from heat pumps to understand how their performance varies with temperature of heat source and heat output	2	2
	4. Where secondary heat requires upgrading to useful temperatures should this be done at source, or at the point of demand	5	1
Distribution	5. What are the benefits from lower temperature networks a. Extent of reduced losses b. Change in capital costs	5	4
	6. Can different piping technology be used for low temperature networks (e.g. plastic pipes, non-insulated return pipes, double pipes)	2	4
	7. What are the difference in terms of network design compared to conventional district heating systems; are there any future proofing considerations.	1	4
Connection	8. Can different heat sources be used at different times of year a. Low temperatures for most of the year b. Higher temperatures during peak heating conditions c. Is there a Legionella regulations question e.g. should these be modified to allow lower temperature DH systems	3	1
	9. What impact on peak heat loss to different retrofit measures have an how do these influence the heating system required a. For a typical size of radiator system by how much does capacity drop when temperature is reduced b. How does this reduction in heating system output compare with reduction in heat demand through building retrofit	3	1
	10. What is the lowest temperature heat source that can be used directly	3	1
	11. What is the impact of temperature change on buildings and system operation a. Can different heat sources be used at different times of year b. Low temperatures for most of the year c. Higher temperatures during peak heating conditions d. Is there a Legionella regulations question e.g. should these be modified to	3 and 4	1

System elements	Question	Section of report	Related objective(s)
	<p>allow lower temperature DH systems</p> <p>e. To what extent can this be achieved by making use of local boiler plant, or plant which already exists within buildings</p>		
	<p>12. What impact on peak heat loss do different retrofit measures have and how do these influence the heating system required</p> <p>a. For a typical size of radiator system by how much does capacity drop when temperature is reduced</p> <p>b. For a typical building how does the peak heat demand vary with improvements to the energy efficiency of the building fabric (insulation, infiltration)</p>	3	1
	<p>13. What is the impact of varying the flow temperatures in systems to meet peak heating loads, and the duration of such peak load periods</p>	3	1
System operation	<p>14. How are low temperature systems controlled</p>	4	1
	<p>15. What is the impact of storage and how is this best deployed</p>	5	1
	<p>16. Is it possible to change from one type of network to another</p> <p>a. What impact does this have on capacity</p> <p>b. Is there an impact on longevity</p>	4	1
Emerging spatial opportunities and pilot study area	<p>17. What areas might be suitable for using secondary heat networks in London</p>	6	3
	<p>18. What is the energy balance, cost and carbon intensity of heat supply from secondary sources in a particular area</p>	6	3

2 Heat capture

2.1 Overview

Heat capture refers to the plant and retrofit measures required at the point of supply to extract low grade heat and deliver it at a suitable temperature to a district heating network. The technical scope of heat capture plant and any retrofit measures required for each of the different secondary heat sources have been described in the Phase 1 report of this study.

This section uses the technical details provided in Phase 1 to assess the performance of each heat source in terms of levelised cost (p/kWh) and carbon intensity (kgCO₂/kWh) of the heat extracted.

Unless otherwise stated, heat is assumed to be supplied at 70°C for use via a district heating network. To support the analysis, a review of heat pump performance at various scales and operating temperatures has also been undertaken and is presented here.

2.2 Heat Pump Analysis

2.2.1 Methodology

An essential aspect of extracting usable heat from low grade sources is the use of heat pump technology to elevate temperatures. The efficiency of any heat pump used therefore has a significant impact on unit cost and carbon intensity of heat supplied. To this end, an in depth review of heat pump coefficient of performance (COP) has been carried out from a review of manufacturers' data, as described in the Phase 1 report. As previously, a central case has been assessed for a 500-1,000 kW unit⁴ and a scale factor applied to adjust for the relationship between scale and performance.⁵

Performance of this heat pump range is highlighted in Figure 2-1 for different source (evaporator) temperatures for four output temperatures on the heat network (condenser) side - 40°C, 55°C, 70°C and 85°C.

The performance of a heat pump is in part controlled by the refrigerant used as it is this medium that transfers the heat energy. Refrigerant properties vary and there is a compromise between flexibility and performance – those with the highest COP can typically operate at a high efficiency for a limited range of input water temperatures and conditions. In this case for example, the limits in refrigerants account for why it is not possible to raise water temperatures from 30°C to 40°C or from 10°C to 85°C - these conditions are outside the standard operating conditions of heat pump refrigerants.

To model the large range of operating conditions, two different refrigerants have been used. For heat networks of 70°C and 85 °C delivered water the units proposed use HFO1234ze (Honeywell Solstice L13) refrigerant; for 40°C and 55°C networks they use R134a.

⁴ Heat Pump data is based on information provided J&E Hall International for high efficiency inverter drive water source heat pumps.

⁵ Based on heat pump performance data provided by Star Refrigeration for 3 to 10MW industrial heat pumps.

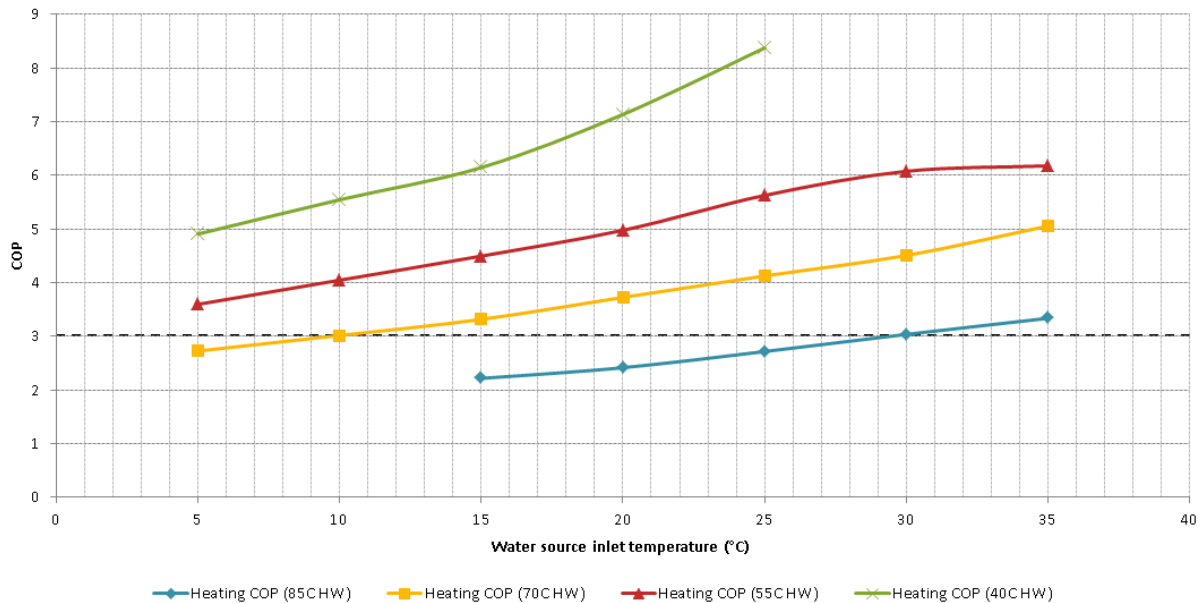

Figure 2-1 – Heat pump COPs by evaporator (source) temperature for four different heat output (condenser) temperatures (500-1000kW scale heat output)

2.2.2 Results

Figure 2-1 shows the relationship between heat pump conditions and COP. A dashed line has been added at a COP of 3 as a guide for the performance below which a heat pump can typically be considered to be unviable because of high heat pump electricity requirements.⁶ For the set of curves presented it can be concluded that elevating temperatures from below 20°C to 80°C and above would be unlikely to yield a cost or energy effective solution under this case. In contrast, elevating temperatures to 55°C and below can expect to retain a high heat pump COP.

Though meeting demand at a low temperature is more efficient from a supply point of view, the building systems in the current building stock which can utilise such temperatures are limited. This is discussed in detail in Section 3.

As a compromise between these factors, a 70°C district heating flow temperature has been assumed for all carbon and cost modelling discussed in this chapter. This is the same as the methodology used in the Phase 1 study. Clearly reducing the return temperature of water back to the district heating network improves the efficiency of the heat source, as well as reducing pumping costs and allowing smaller diameter pipework to be used. This is a key requirement for low temperature heat networks and is discussed in detail in Section 4.

⁶ Based on recommendations from previous work by the GLA and notwithstanding any future decarbonisation of the electricity network. GLA Steering group meeting, March 2013.

2.3 Cost and Carbon Intensity Analysis

2.3.1 Methodology

The methodology used to arrive at cost and carbon intensities for the heat supply from each source is summarised in Figure 2-2.

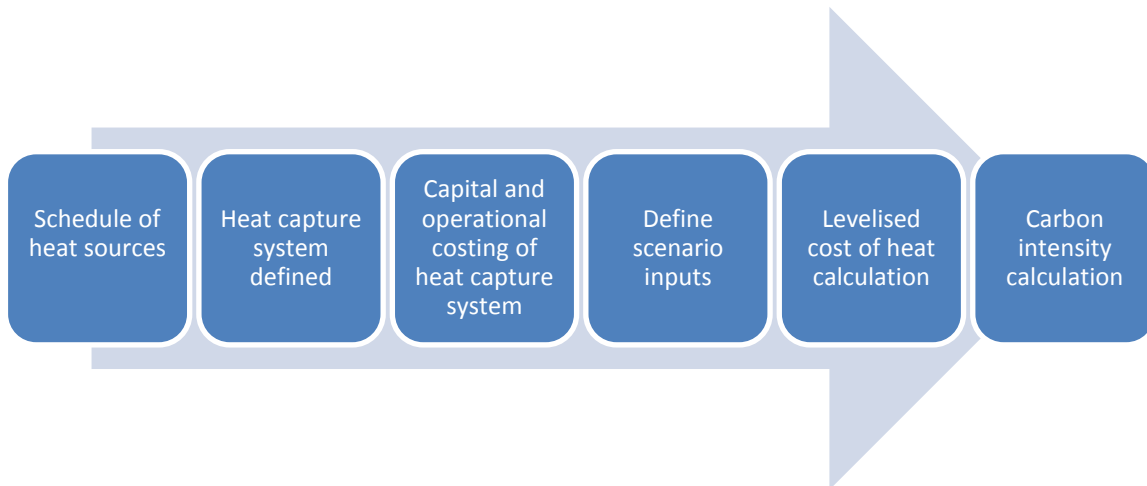

Figure 2-2 – Outline methodology for heat capture section

2.3.1.1 Capital and operational costs

An outline bill of quantities has been developed for each heat source based on the Phase 1 technical scopes showing the following information:

- Details of the plant required to deliver heat at the required temperatures (e.g. heat pumps / heat exchanges)
- Typical heat pump capacity for an indicative supply source example
- Temperature(s) available at heat source
- Heat source 'retrofit' measures required to enable heat extraction / capture
- Lifetime of plant

This information was used to determine:

- Capital cost
- Maintenance and energy input costs
- Levelised unit cost of heat in p/kWh

2.3.1.2 Levelised cost of heat

The levelised cost of heat has been calculated as the total cost of generation divided by the total heat generated (MWh) over a defined period. Costs include capital costs associated with heat capture, operations and maintenance and the cost of fuel (in this case, 'fuel' is either electricity for

running heat pumps or, in the case of the counterfactual, gas). For the purposes of this study any costs associated with the distribution network (ie. pipes and their installation) have been excluded as it is assumed that all heat networks will be in place prior to the utilisation of secondary heat sources.

A counterfactual case has been included for comparison purposes. This case assumes a 90% efficient 4MW gas boiler supplying heat into a district system from a central energy centre.

Costs have been explored across the different scenarios out to 2050 described in the Phase 1 report. The energy price and carbon intensity assumptions for these scenarios are outlined in Table 2-1 below (and included in Appendix A with references). Key assumptions are as follows:

- Under the Business as Usual (BAU) scenario it is assumed that electricity and gas prices increase modestly and there is no change in carbon intensity of the grid out to 2050
- Under the Co-ordinated and Ambitious scenarios it is assumed that energy prices are higher than under the BAU scenario in both 2030 and 2050
- In both the Co-ordinated and Ambitious scenarios, grid electricity carbon intensity falls in 2030 and again in 2050
- In the Ambitious scenario, grid gas carbon intensity also falls (due to an increase in the injection of low carbon biogas to the existing gas network).

For all scenarios a discount rate of 3.5%⁷ is assumed and no financial incentives have been modelled.

Table 2-1 – Data for scenario modelling

Data	BaU	Co-ordinated	Ambitious
	Current (2010)		
Electricity price (p/kWh)	7.1	n/a	n/a
Gas price (p/kWh)	1.9	n/a	n/a
Grid carbon – electricity consumed (kgCO ₂ /kWh)	0.542	n/a	n/a
Grid carbon – gas consumed (kgCO ₂ /kWh)	0.185	n/a	n/a
	2030		
Electricity price (p/kWh)	10.1	12.1	14.1
Gas price (p/kWh)	2.0	3.2	4.4
Grid carbon – electricity consumed (kgCO ₂ /kWh)	0.542	0.104	0.104
Grid carbon – gas consumed (kgCO ₂ /kWh)	0.185	0.185	0.176
	2050		
Electricity price (p/kWh)	10.1	12.1	14.1
Gas price (p/kWh)	2.0	3.2	4.4
Grid carbon – electricity consumed (kgCO ₂ /kWh)	0.542	0.023	0.023
Grid carbon – gas consumed (kgCO ₂ /kWh)	0.185	0.185	0.176

⁷ HM Treasury. The Green Book, 2011. http://www.hm-treasury.gov.uk/d/green_book_complete.pdf

2.3.1.3 Carbon intensity

The carbon intensity associated with the heat pump energy requirements is determined by applying the carbon factors in Table 2-1 against the electricity used by each heat pump. For the counterfactual case this relates to gas required for the boiler rather than electricity consumption and there is no heat pump requirement in this case. As with levelised costs, the carbon intensity is levelised by dividing the absolute tonnes of carbon⁸ over the system life by the energy delivered over the same period.

2.3.2 Results and discussion

2.3.2.1 Levelised cost

A summary of levelised costs for BAU 2010 scenario is given in Table 2-2 below. A typical 'heat infrastructure capacity (MWth)' has been assessed and costed for each heat source. The total levelised cost has been split into the levelised infrastructure cost and the levelised energy cost, the former including capital, operational and maintenance costs and the latter the cost of fuel for the heat pump (where required) or in the counterfactual case, the gas boiler. The period over which the levelised costs have been calculated relates to the estimated equipment lifetime and is 20 years in most cases.

A more detailed breakdown of capital costs is given in Appendix B. Levelised costs for all scenarios are discussed in chapter 2.3.2.3.

⁸ Only operational carbon has been included. No attempt has been made to assess embodied carbon.

Table 2-2 – Levelised costs of each secondary heat source under the 2010 BAU scenario

Technology	Heat infrastructure capacity (MWth)	Indicative system costs (£)	Levelised cost of delivered heat at 70°C	
			Infrastructure cost (p/kWh)	Energy cost (p/kWh)
Ground source - open loop	0.378	£411,600	0.89	2.27
Ground source - closed loop	0.288	£465,600	1.29	2.38
Air source with storage	12	£5,666,000	1.07	3.15
River source heat rejection	20	£7,255,600	0.47	2.04
Large power stations	20	£7,245,600	0.84	1.28
Energy from waste	20	£7,245,600	0.44	1.28
Building HVAC – office and retail	0.5	£249,800	1.56	1.63
Industrial sources	0.5	£216,200	0.55	0.00
Supermarkets (non-HVAC)	0.5	£209,800	0.45	1.50
Data centres (non-HVAC)	3	£1,492,400	0.81	1.23
Water treatment works	20	£7,245,600	0.60	1.86
London Underground	0.05	£71,000	1.84	2.09
National Grid electrical infrastructure	1.3	£641,300	1.18	0.93
UKPN	0.25	£149,200	1.77	0.96
Sewer heat mining	0.5	£280,400	0.65	2.20
<i>Counterfactual</i>	<i>4.0</i>	<i>£249,800</i>	<i>0.04</i>	<i>2.11</i>

The results in Table 2-2 have been used to plot a marginal cost curve for the BAU 2010 scenario and are ordered to highlight the most financially attractive sources. Figure 2-3 is reproduced from a larger scale graph in Appendix C.

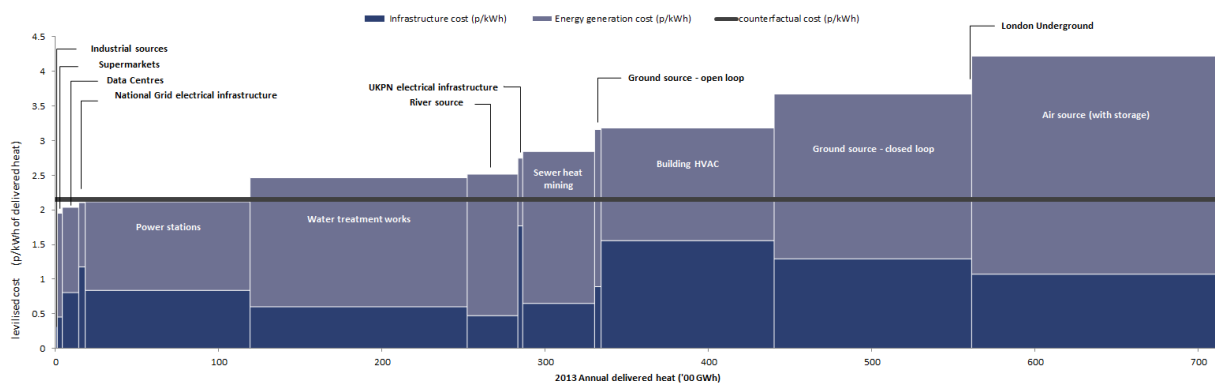

Figure 2-3 – Heat supply marginal abatement cost curve BAU 2010. The counterfactual levelised cost is indicated by the grey line.

These results demonstrate that heat sources available at higher temperatures and with high load factors are most cost effective. The most favourable sources are the industrial sources where it is assumed that heat can be captured directly at 70°C without the need for a heat pump. Sources with less economic potential than the counterfactual case are primarily the environmental sources. The heat supply of these sources is limited seasonally and of a lower grade than that associated

with heat 'rejection' from industrial or commercial sources thereby requiring more heat pump energy to upgrade them to a useful temperature.

2.3.2.2 Carbon intensity of heat sources

The carbon intensity of the different heat supply sources under the different scenarios is given in Figure 2-4.

Industrial sources can recover exhaust or engine jacket heat at or near the district heating supply temperature and so have no or limited carbon impact associated with heat supply.

The highest carbon intensities are for the environmental sources, as these provide the lowest grade heat and need significant amounts of electricity to upgrade temperate to 70°C. Under BAU 2010 the environmental sources provide heat above or close to the carbon intensity associated with heat from gas boilers. Air source heat pumps are the only supply source which provides heat at a carbon intensity above that of natural gas boilers.

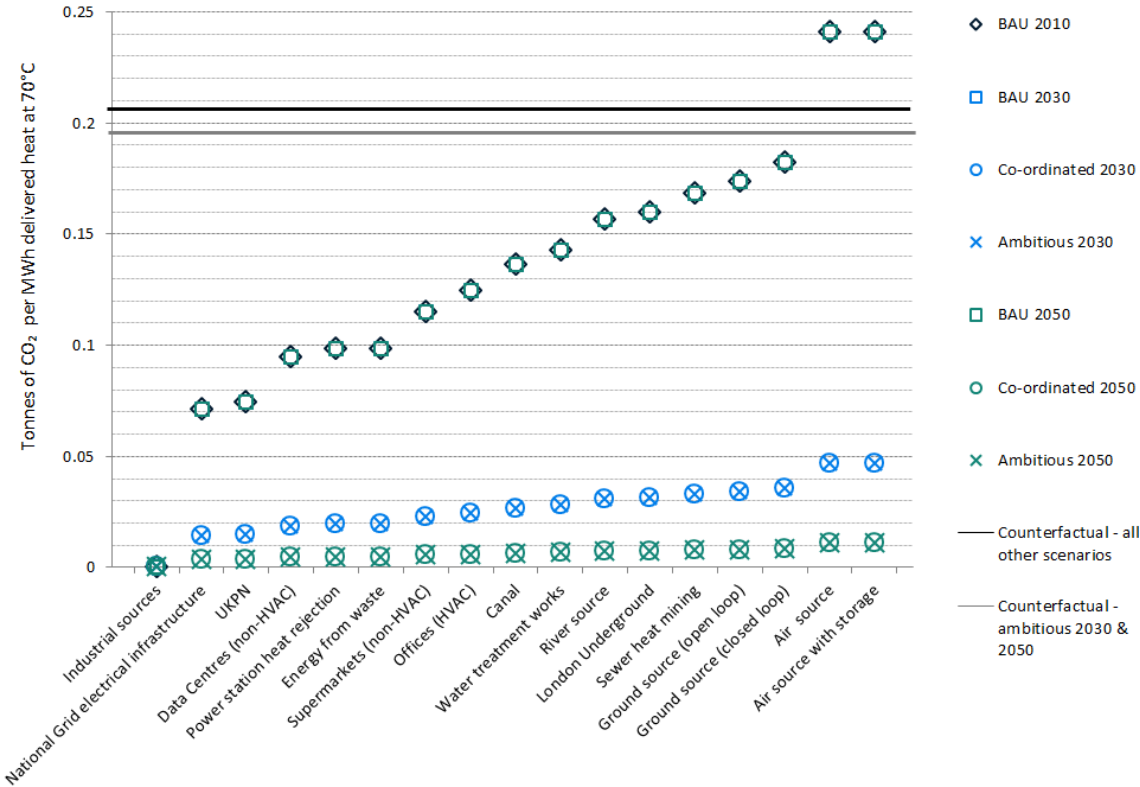

Figure 2-4 – Carbon intensity of heat supply sources by scenario

There is a significant carbon saving over the counterfactual case for all sources under the Co-ordinated and Ambitious scenarios. In these cases the carbon intensity of the electricity network is assumed to fall so that the carbon intensity becomes comparable with and subsequently less than that of gas. The large effect of this on secondary heat sources is apparent; the carbon intensity of all sources becomes over 4 times less than the counterfactual case for these scenarios. By 2050 the carbon intensity of all secondary heat sources is virtually zero. Clearly this conclusion is highly dependent on the decarbonisation of the UK electricity grid network.

2.3.2.3 Cost and carbon: combined analysis

The relationship between carbon intensity and levelised cost for the BAU 2010 scenario is important when considering the overall viability of heat sources. This relationship is displayed in Figure 2-5 (the diameter of each circle represents the availability of each resource for London as a whole).

The layout of the chart means that the nearer to the bottom left corner (low emissions, low cost), the more attractive the technology. The grey lines represent the counterfactual case, beyond which the heat pump technology can be considered comparable to or worse than large decentralised gas boilers.

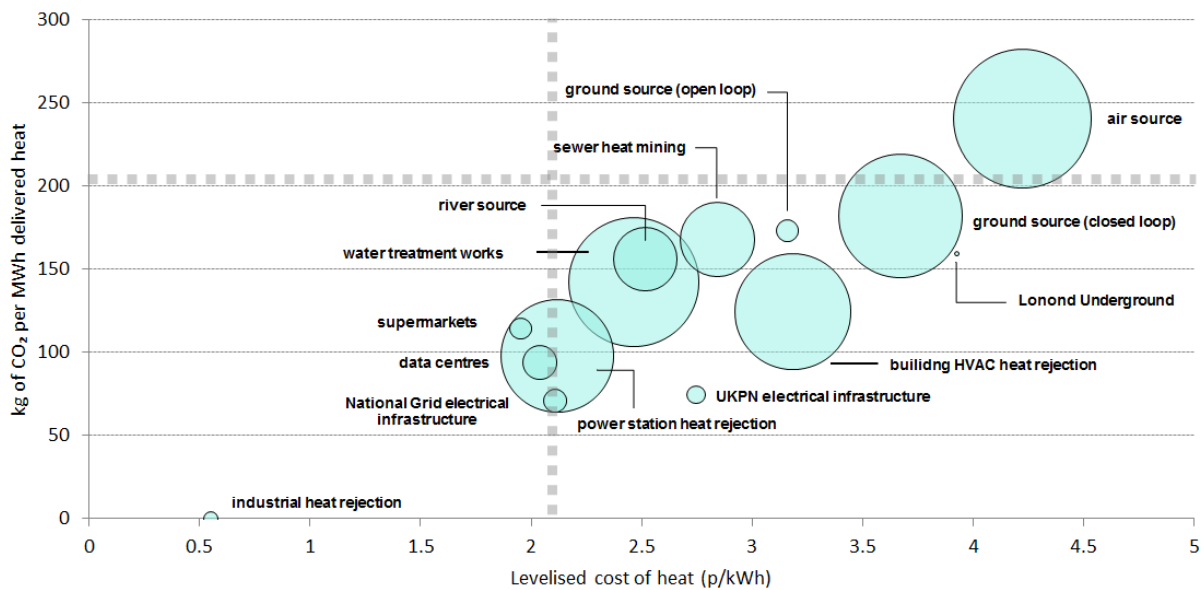

Figure 2-5 – Carbon intensity v levelised cost of secondary heat sources in London (BAU 2010)

This figure clearly demonstrates that industrial heat rejection is the most attractive source as, when recovered from flue stacks or engine jackets, it requires no heat pumps to upgrade to the temperature required for the network. The quantity of heat available from these sources across London as a whole is however limited.

In contrast, air source heat pumps are both expensive and have high carbon intensity as they require a large amount of heat pump electricity to supply in to the network. Load factors for this technology are also low, as it is assumed that heat would not be recovered below a 5°C ambient air temperature. The benefit of air source would be in scale: the energy potentially is available in large quantities.

The impact of the scale at which the heat can be captured also becomes apparent in the analysis of this graph. Both the COP and load factor for sewer heat mining are higher than those of river source heat pumps yet, on this graph, it appears a less attractive technology. This is due to the assumption that a heat recovery station at a water treatment plant will be afforded more space and have a higher maximum capacity than a location breaking into an existing sewer where space is likely to be a constraint. As such the heat pumps specified are an order of magnitude larger benefiting from a lower cost per MW. This lower cost is reflected in a lower levelised cost.

Figure 2-6 shows the projection of results for the 2050 Co-ordinated scenario. The results show a similar spread to the BAU 2010 graph however the scale on the y-axis has changed as the carbon

intensity predicted is far less than previously. The counterfactual carbon case is not displayed as it is off the scale of the graph (205 kg CO₂/MWh). As such all sources have an increased environmental benefit over the 2010 BAU case, making those at a higher cost more attractive than previously because of their environmental benefits. As before, this analysis is prior to considering future financial incentives – possibly greater in this case because of an increased margin between secondary sources and the counterfactual.

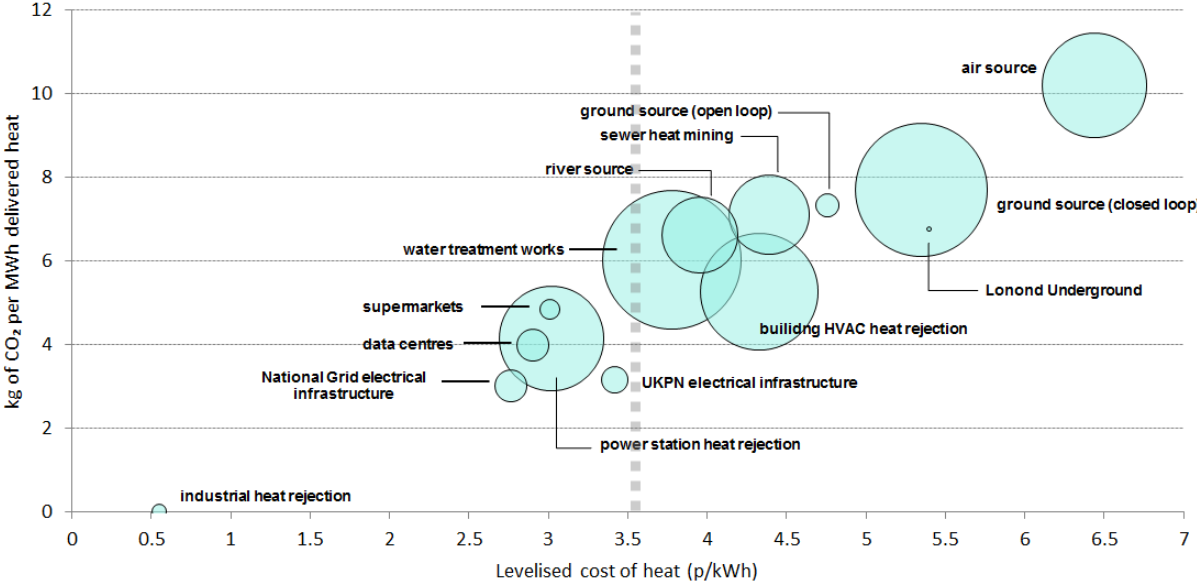

Figure 2-6 – Carbon intensity v levelised cost of secondary heat sources in London (Co-ordinated 2050)

The counterfactual cost shown is dominated by the levelised cost of energy (98% of the total cost). This contrasts to the secondary heat sources where capital costs are a much more significant proportion of the total costs (Figure 2-7). This has a knock on effect when considering the commercial viability of certain heat sources as although they may be more cost effective over their lifetime, their upfront costs are high. Electrical transformer and building HVAC heat rejection have particularly high ratios of infrastructure to energy costs because of their low load factors caused by the intermittence of supply from these sources. The grade of heat available from these sources is relatively high (55°C and 28°C respectively) and so the total levelised costs remain competitive. They are therefore less sensitive to variations in future energy prices, though requiring a greater capital investment.

This is demonstrated as electricity prices inflate under the different scenarios as shown in Figure 2-7 below. This graph shows the levelised cost of each secondary heat source under each scenario and compares them against the counterfactual. The sources have been ranked with the lowest cost sources on the left and highest cost sources on the right. The share of levelised cost associated with plant and equipment is shown in dark colours compared with that associated with energy input in light colours.

Energy from waste has been separated from a conventional gas fired power station case (e.g. combined cycle gas turbine) in Figure 2-7 to highlight the sensitivity of the supply sources to variations in load factors. Both of these sources have the same constraints in all other fields and the same levelised cost of heat pump energy but their differences in load factor and the resulting decrease in annual delivered heat cause the levelised capital costs to double from one to the other. This is apparent because although the same heat pump infrastructure is being installed for both

sources it is expensive and so relies on high run hours to pay back this cost – an average combined cycle gas turbine has approximately half the annual run hours of an energy from waste plant. Clearly the run hours of gas fired power plants will vary according to energy prices, operating strategies and energy demand, so this result considers only the average case.

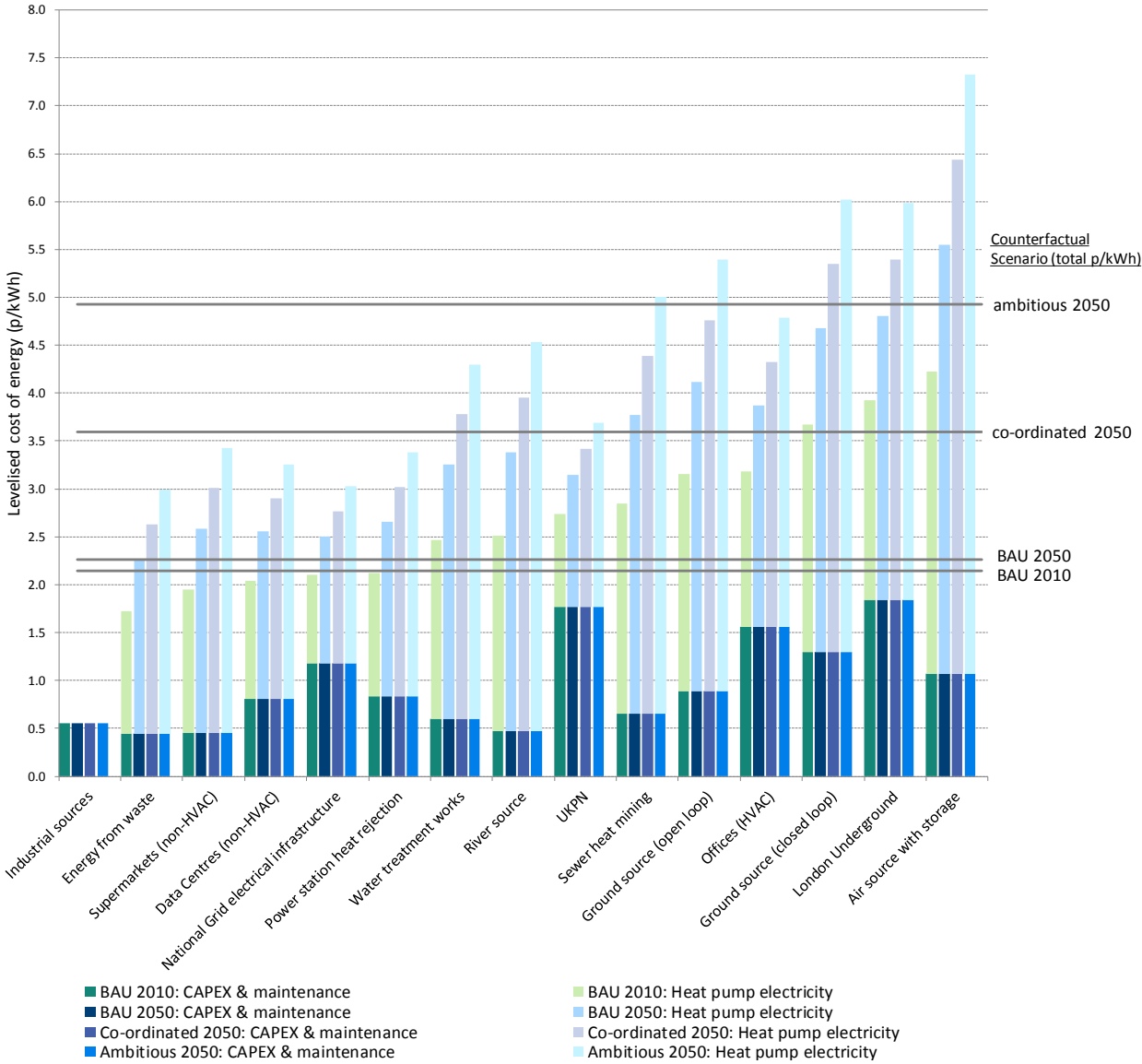

Figure 2-7 – Levelised heat generation costs at the point of generation for all scenarios

2.4 Conclusions

For most secondary heat sources it is necessary to upgrade the heat to a temperature at which it can be directly used within a district heating system. This means using heat pumps. The implications of this are two fold:

- The carbon intensity of the heat supplied is directly related to the carbon intensity of the electricity supply driving the heat pumps. If the carbon intensity of the electricity grid falls (as planned) the carbon intensities of secondary heat sources will also fall. Under the future

scenarios modelled here, the carbon intensity of all secondary heat sources would be more than four times less than the counterfactual case, and even lower by 2050.

- The levelised cost of the secondary heat supplied is related to the cost of electricity driving the heat pumps. Those sources installed with heat pumps with a higher capital cost but higher efficiency will be less sensitive to electricity prices than those sources with a lower capital cost and lower efficiency. Under the scenarios modelled here, as the margin between gas and electricity prices increases the levelised cost of most secondary heat sources falls below that of the counterfactual case.

In terms of specific heat sources, the following observations can be made:

- Air source heat pumps provide abundant heat but at a higher cost and higher carbon intensity than gas boilers under 2010 conditions. The heat pump energy required to convert air source heat to usable temperatures means that their associated unit cost and carbon intensity are highly sensitive to progress on decarbonising the electricity grid and to electricity prices.
- Heat supply from electricity substations is the lowest carbon after industrial heat recovery, but costs are dependent on scale
- Under BAU 2010 heat recovery from supermarkets, power stations, national grid substations and data centres is comparable to the cost of heat from a gas boiler
- Under the Co-ordinated 2050 scenario heat recovery from industrial sources, supermarkets, power stations, national grid substations and data centres are lower cost than heat from a central gas boiler
- As electricity prices increase in BAU 2050 only heat from industrial sources and energy from waste remain competitive with natural gas, assuming that natural gas prices do not increase significantly
- Heat from air source, ground source and London Underground are significantly more expensive than heat from gas boilers in all scenarios.
- Load factors of power plants have a large effect on the levelised cost of delivered heat because of the high associated capital costs.
- Larger heat pumps typically have lower levelised capital costs because of both economies of scale and slightly higher efficiencies.

In the short term secondary heat system projects should focus on recovering heat from sources that have the highest possible temperatures, including heat from industry and existing gas engine generators. These sources also have the lowest carbon intensity.

Longer term other options are available. Clearly, improving the efficiency of heat pumps would reduce both cost and carbon intensity of upgrading low temperature heat sources. In addition, adapting end user systems to be better able to utilise lower temperature heat would be beneficial. The analysis in this chapter shows that heat pump efficiency is far greater when the temperature upgrade required is lower. Thus heat pump efficiency roughly doubles between a heat supply temperature of 85°C compared with one of only 55°C. The more that buildings can be designed to make use of lower temperature sources without the need to upgrade temperatures, the more cost effective these secondary sources will become. This issue is discussed in the next chapter.

3 Heat connections: buildings

3.1 Overview

'Connections' refers to all the plant and retrofit measures required at the consumer end of the network to enable the effective use of low temperature sources of heat. This includes all aspects of the building and its internal systems that relate to the provision of heat to meet occupant needs, namely:

1. the heating systems within the building (e.g. radiators, underfloor heating) and how they are used
2. the thermal efficiency of the building fabric
3. the design of the pipe work within the building (the 'secondary system') connecting the external network to the internal building heating systems

This chapter uses building modelling techniques to explore the first two of these issues. The following chapter uses case studies to understand and make recommendations in relation to the third. A summary outline of the approach is given in Figure 3-1 below.

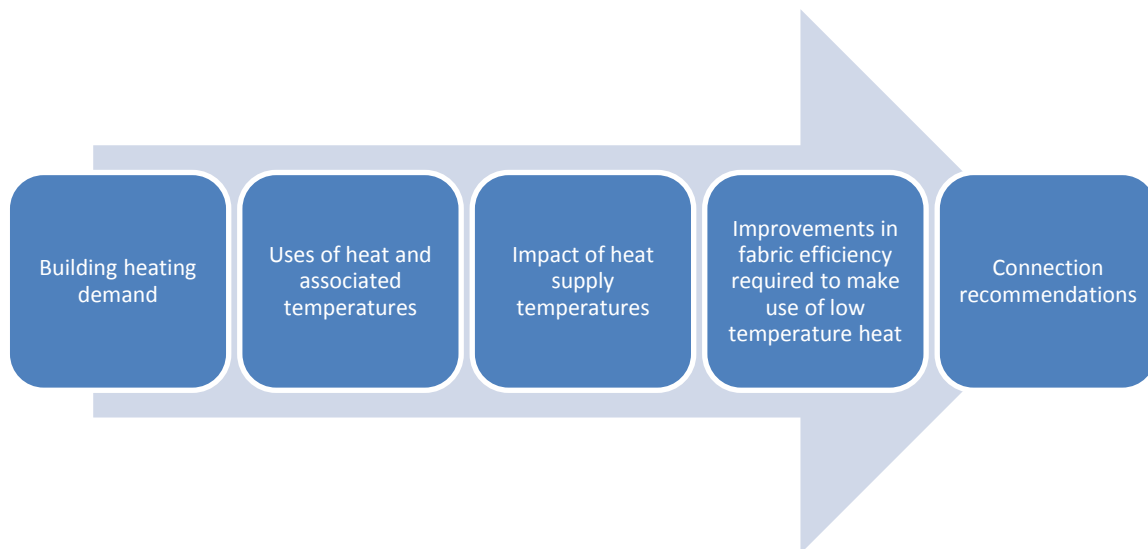

Figure 3-1 – Approach to analysis of issues associated with heat connections within buildings

3.2 Building heating systems

Heating systems in buildings are composed of three elements:

- Heat sources
- Distribution networks
- Heat emitters

This section reviews the types of distribution networks and heat emitters currently in use in buildings in London. Understanding these systems, and the flow temperatures that may be applied

in each case, is important in understanding how low temperature heat can be used within buildings. For full descriptions refer to CIBSE Guide B1⁹.

Heat distribution

The following media can be used to distribute heat within buildings:

- Hydronic systems¹⁰
 - Low temperature hot water (40-85°C, low pressure)(LTHW¹¹)
 - Medium temperature hot water (~ 100 - 120°C, < 5bar pressure)(MTHW)
 - High temperature hot water (>120°C, < 10bar pressure)(HTHW)
- Steam (usually used in hospitals and is often in older buildings e.g. Palace of Westminster)
- Electricity
- Air

By far the most common heat distribution media are thought to be low temperature and medium temperature heat. LTHW systems are sometimes further subdivided into very low temperature hot water (~50°C, low pressure).

LTHW systems have historically been designed to operate at 82-71°C flow and return temperatures as this keeps return temperatures above the level where condensing of combustion water vapour occurs (~66°C), which has traditionally been avoided. This has the added advantage of maintaining high mean radiator temperatures, reducing required heat emitter areas. The advent of condensing boilers means it is now common to design heating systems on a 70-50°C flow and return system, lowering the mean radiator temperature to 60°C and enabling improved efficiency of condensing boilers. The relative split of building heating system distribution media in London is not known and further research is required to determine this, outside the scope of the study.

Previous guidance for district heating schemes suggested modifying temperatures to operate at 80-50°C flow and return (mean radiator temperature of 65°C), providing a reduction of 25% in peak heat loss could be made. Requirements to maintain Legionella disinfection temperatures of 65°C within hot water storage and circulation systems suggest a minimum network temperature of 70°C¹².

Heat emitters

The following heat emitters may be used to deliver heat directly to spaces:

- Radiators: Normally found on LTHW circuits. Convective component 50 – 70%. Manufacturer's quoted output usually assumes a 50°C difference between water and air. Reductions in temperature are permissible if the unit size is increased to compensate, assuming correct

⁹ Chartered Institute of Building Services Engineers (2002): CIBSE Guide B1, Heating

¹⁰ Chartered Institute of Building Services Engineers (2002): CIBSE Guide B1, Heating, Table 4.3

¹¹ LTHW and MTHW are also often described as low/medium pressure hot water (LPHW or MPHWH)

¹² DETR (1998) Good Practice Guide 234: Guide to community heating and CHP Commercial, public and domestic applications

<http://www.chpa.co.uk/medialibrary/2011/04/07/81f83acc/CHPA0003%20Good%20practice%20guide%20to%20community%20heating%20and%20CHP.pdf>

sizing initially. Temperature change across the radiator should be a minimum of 12°C in a correctly commissioned system.

- Fan convectors: Often fed with low temperature hot water but can be electric (up to 5kW in capacity). The additional convection provided by the fan can allow lower temperatures than radiators to be used; 40°C can be reached.
- Unit heaters: May be electric or served by low temperature hot water. In the hot water case entering and leaving temperatures are typically ~ 95 to 75°C, respectively.
- Ceiling panels: Typically operated at 79 to 85°C. May be electric or low temperature hot water driven. Radiant component ~ 65%.
- Underfloor heating: Operating temperatures are typically around 30 – 45°C and so are commonly used in conjunction with air or ground source heat pumps. Maximum allowable surface temperature is 29°C to avoid discomfort. Circuit temperature and heat load determine required spacing of pipework within the floor screed. Lower temperature systems require closer spacing. Output is limited to around 60W/m².
- Wall heating: Similar to underfloor heating but with reduced output due to the lower mean temperature difference between the air and wall surface (warmer air higher up). This is not a common type of system.

Section 3.3 analyses the impact of reducing distribution temperatures on heating system emitters and on the ability to maintain internal design temperatures during peak heating conditions.

The extent to which heating systems can be oversized is not clear, but anecdotally we are aware of suggestions of oversizing by up to 50%. Further research is required to understand the spread and extent of oversizing of heat emitters in the London building stock. Oversizing may have the unexpected benefit of making reductions in flow temperatures acceptable in many buildings.

Domestic hot water

Legionella regulations require any domestic hot water storage to be disinfected on a regular basis by raising temperatures to a minimum of 65°C¹³. This limits the practical district heating network temperature to around 70°C. Domestic hot water is required to reach 50°C after 1 minute of operating a tap. In practice temperatures higher than this can cause scalding and are rarely required in domestic and most non-domestic buildings.

Neglecting the storage disinfection requirements it is possible to operate an indirectly connected heat network at 55°C and maintain a 50°C outlet temperature. This does raise potential health concerns as after a tap or shower is stopped, water in the system would then cool to below 50°C and hence be at risk of Legionella growth before being drawn off for subsequent usage. As this water would never have been heated above disinfection temperature it could lead to a higher risk of bacterial growth.

In new flats in Denmark they operate their systems at 50°C and deliver hot water at 45°C, minimising health risk by having negligible storage of hot water in their systems. Storage is limited

¹³ Building Regulations Approved Document G says that control of legionella should be done in accordance with the HSE Approved Code of Practice L8. These requirements are echoed in the CIBSE guidance document TM13 2002.

to 0.5l in the plate heat exchanger and 3l in the domestic hot water pipework to the outlet. Achieving the latter requires careful location of outlets relative to heat exchangers. The Danish approach is illustrated in Figure 3-2.

An alternative solution is to use chemical dosing with chlorine dioxide to disinfect the lower temperature water. In UK health and safety policy, the Approved Code of Practice on Legionnaires' disease (ACoP L8) lists this as an appropriate method of legionella control, and recommends levels of 0.5 mg/l for it to be effective. This dosing could take place in a cold water storage tank.

Further work is clearly required to understand the impact on health risks of operating heat networks below 70°C. Work is being undertaken by the IEA in this area (see Section 4).

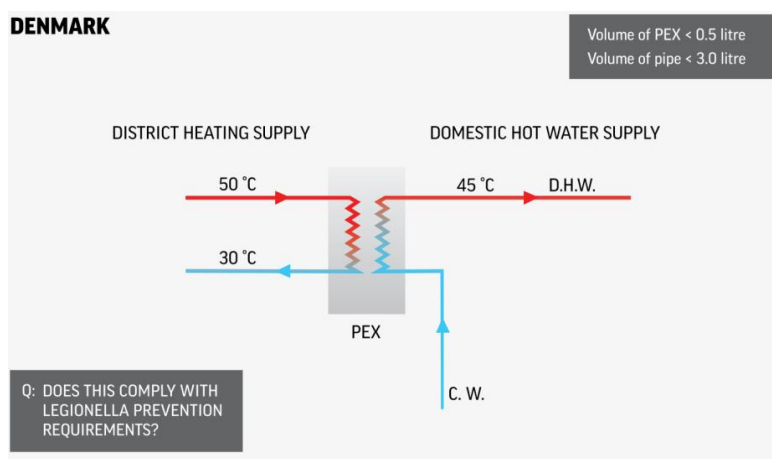

Figure 3-2 – Danish heat network temperatures in new buildings for domestic hot water supply

3.3 Building performance

3.3.1 Modelling methodology

To determine the impact of heat temperature on the performance of building heating systems dynamic thermal models of four types of building have been developed using specialist software, IES VE 2012:

- Residential – high build quality (thermally efficient)
- Residential – low build quality (thermally inefficient)
- Non-residential – high build quality (thermally efficient)
- Non-residential – low build quality (thermally inefficient)

The high build quality models had double glazing and building envelope elements with U-values of 0.15 W/m²/K. This corresponds to PassiveHaus or zero carbon homes fabric energy efficiency standard cases¹⁴ and may be taken as the upper limit of fabric performance. A low infiltration rate of 0.17 air changes per hour was also applied.

¹⁴ Zero Carbon Hub (2013) DEFINING A FABRIC ENERGY EFFICIENCY FOR ZERO CARBON HOMES <http://www.zerocarbonhub.org/building.aspx?page=2>

The low quality building models were based on typical UK solid wall construction with single glazing. U-values of 2.0 W/m²/K were applied to all envelope elements and an infiltration rate of 1.5 ACH was applied to all spaces. Typical occupancy, lighting and internal equipment profiles were added in each case, with the non-residential case considered typical office profiles to be representative of non-domestic buildings.

In the residential case the best and worst case models were run to establish an energy efficiency rating (EPC rating) based on SAP calculations – a recognised rating system for energy efficiency in dwellings. The models were then run again to obtain annual heating loads. It was assumed that all residential buildings are heated with gas-fired central heating running on flow and return temperatures of 82°C and 71°C, respectively, and that all systems including heat emitters (radiators) are accurately sized to the peak heating load¹⁵. Applying standard manufacturer’s radiator temperature and output relationships, the reduced maximum output of the ‘existing’ central heating systems were calculated for lower flow temperatures from a range of future low temperature district heating schemes. The temperatures considered are described in Table 3-1 and are as follows (temperatures not modelled are in italic, but shown for reference):

- Base case – non-district heating
- Low temperature (LT) Type A
- LT Type B, and
- LT Type C

Table 3-1 – District heating temperatures modelled in building heat performance calculations

Technical classification	Type of system	Description	Temperature characteristics	Pressures
Base case – non-district heating	Conventional radiator system	Wet central heating system sized at pre-condensing boilers normal industry practice	Flow – 82 °C Return – 71 °C	< 6bar
<i>Base case – district heating</i>	<i>Conventional temperature (LTHW) heat network</i>	<i>Conventional district heating network, cannot connect to low temperature sources without heat pumps</i>	<i>Flow – 85-95 °C Return – 55 °C Flow can be raised to 110 °C in high load conditions (then MTHW)</i>	<i>6-16 bar</i>
LT Type A	Low temperature heat network	Conventional district heating network, operating at lower temperature, highly likely to use heat pumps to upgrade low temperature sources	Flow – 70 °C Return – 50-35 °C	<6 bar
LT Type B	Very low temperature heat network	District heating system, operating at very low flow temperature, still capable of supplying domestic hot water via plate heat exchangers	Flow – 55 °C Return – 35-25°C	<6 bar

¹⁵ In practice this assumption may not be accurate and many heat emitters are likely to be oversized

Technical classification	Type of system	Description	Temperature characteristics	Pressures
LT Type C	Ultra low temperature heat network	District heating system, operating at extremely low flow temperature and able to provide heat via underfloor heating to high fabric efficiency buildings only	Flow – 40 °C Return – 20°C	<6 bar
LT Type D	Ambient district energy sharing system	Warm and cool pipes providing storage and coupling between buildings which are in a mixture of heating and cooling mode. Reversible heat pumps are used at each building to upgrade to higher or lower temperature thermal energy for chilled water and heating	Warm pipe – 15-30 °C Cool pipe – 5-15 °C	<6 bar

The proportion of the total heat load that may be covered by a lower temperature source was found by selecting all loads that are below the calculated reduced maximum output of the heating load profile and dividing by the total load. This procedure was applied for the best and worst case models. This allowed values to be entered for EPC ratings of C and E. The corresponding values for the remaining ratings were calculated by interpolating or extrapolating between the obtained values. Values above an EPC rating of C were assumed to be the same as C since this approximately corresponded to PassiveHaus or zero carbon homes fabric energy efficiency standard cases¹⁶.

The non-residential cases were treated in a similar way but rather than obtaining an EPC rating, the obtained heat loads were used in conjunction with figures for typical end-use energy and small power to calculate a likely total energy per unit floor area for both fabric quality cases. Reduced heating system outputs were calculated in the same way as in the residential cases and provided proportional heating load figures for cases of buildings with up to 100 kWh/m² and 400 – 500 kWh/m² total energy use. The remaining energy use categories were then filled in through interpolation and extrapolation.

3.3.2 Results and discussion

3.3.2.1 Impact of heat supply temperature on ability to meet peak loads

Peak heating loads occur when external temperatures are lowest. Systems are usually designed to maintain a specific internal temperature during an external ‘design temperature’ of usually around minus 4°C.

The output of all central heating systems will vary with flow and return temperature. The majority of systems in London use radiators with flow and return temperatures of typically at 82°C and 71°C, respectively. If these systems were to accept reduced flow and return temperatures, their heat output would fall accordingly. Figure 3-3 shows the relationship between flow temperature and related heat output for mean temperatures relative to 76.5°C, the mean of an 82-71°C system.

Mean temperatures are indicated for the 82-71°C system (blue), which has relative output factor of 100%. All other system temperatures are compared to this. Reducing the flow and return

¹⁶ Zero Carbon Hub (2013) Defining a fabric energy efficiency for zero carbon homes <http://www.zerocarbonhub.org/building.aspx?page=2>

temperature for the same system to 70 and 50°C, respectively, will yield a relative heat output of 64%. Likewise, reducing to 55-35 °C would yield 35% of the peak heat output. With 40-20°C, the relative output is just 10%.

This reduced output is equivalent to a reduction in capacity. The relationship between mean temperature and capacity allows us to understand what impact lower temperature district heating sources would have on the ability of currently installed systems to heat buildings.

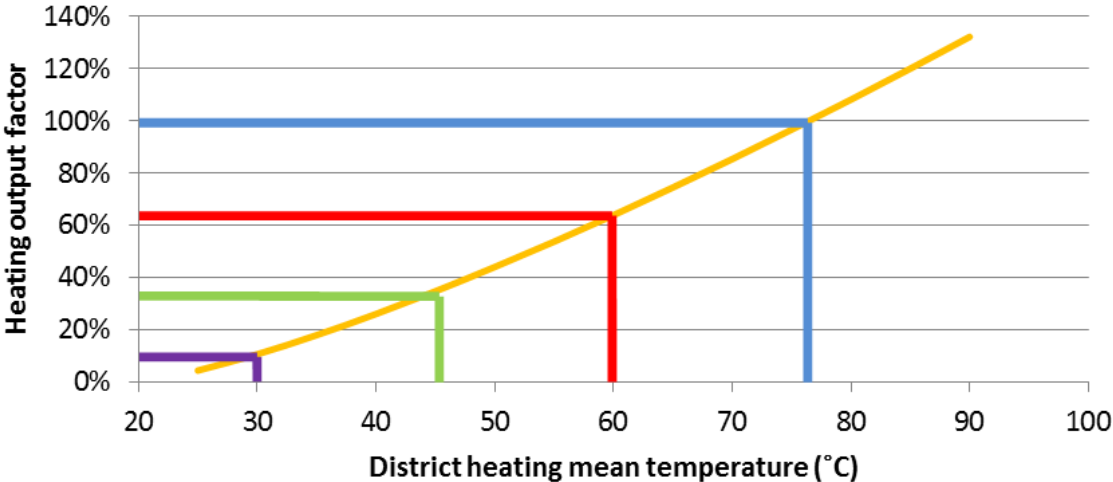

Figure 3-3 – District heating mean temperature vs heat output factor for radiator system peak load. The blue line highlights the mean temperature and corresponding output factor for flow/return temperatures of 82/71°C; the red line highlights the equivalent for 70/50°C; the green line for 50/35°C; and the purple line for 40/20°C. The colours correspond to those used in figures 3-5 to 3-8 for the same flow and return temperatures

Modern underfloor heating systems are designed to operate at lower temperatures and, due to their large surface area, represent a good practical limit to the minimum temperatures that can usefully heat a space. Figure 3-4 shows the output of a typical system for a range of flow temperatures.

The models of residential and non-residential buildings with high performance fabric constructed for this study yielded peak heating loads of 25 and 13 W/m² respectively. Assuming these are limiting cases of high performance, a realistic minimum flow temperature that could be employed in any heating system would be around 26°C. Thus, any district heating scheme would have to supply temperatures of at least this temperature. However, given current installed systems are largely radiator-based, the minimum permissible flow temperature would have to be considerably higher. Supplying domestic hot water is also likely to require higher temperatures, as discussed in Section 3.2.

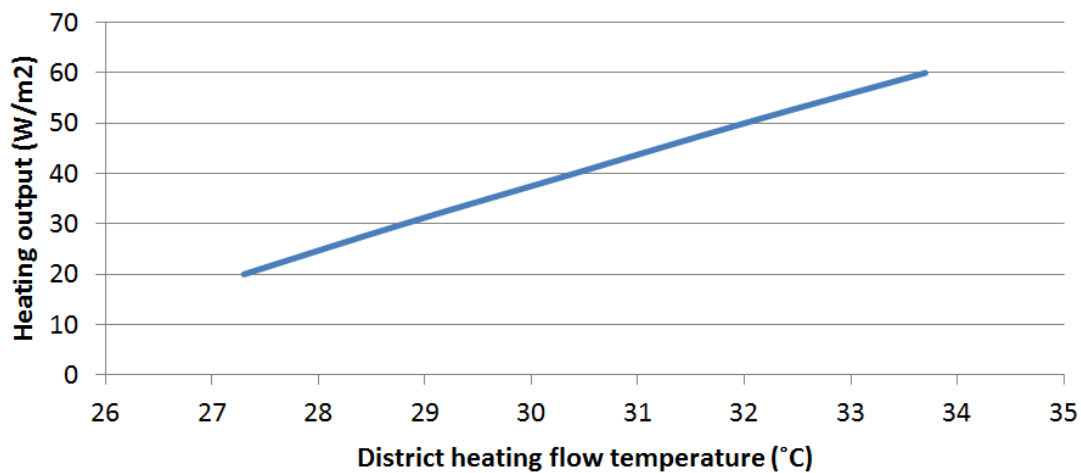

Figure 3-4 – Heat output vs flow temperature for a typical underfloor heating system with tiled finish¹⁷

3.3.2.2 Impact of heat supply temperature on ability to meet annual heat demand

The heat loads from each of the models described in Section 3.3.1 have been extracted and plotted as load duration curves (Figure 3-5 to Figure 3-8). The percentage of the total annual heat load that can be met by the lower temperature sources is indicated on each curve. Note that these demands exclude domestic hot water and that the heating demands are not corrected for occupancy or controls e.g. they assume a heating demand whenever the internal temperature falls below a set point. This has the result of indicating a longer heating season than might be expected in practice.

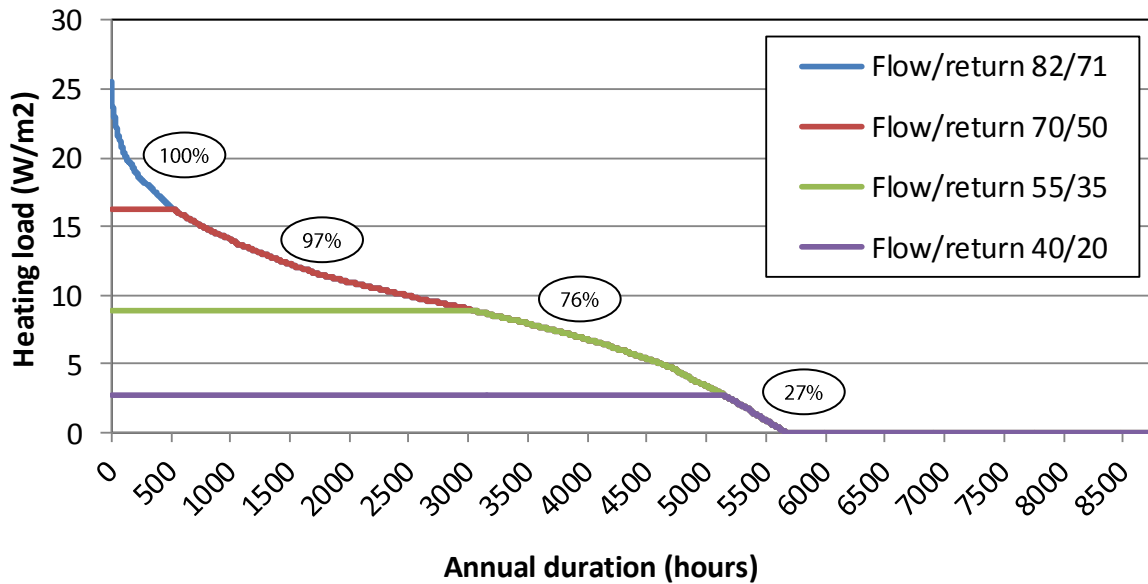

Figure 3-5 – Annual heat demand percentage met by heat supply temperatures – residential high build quality

¹⁷ Thermotec (2013) Private correspondence with Giles Gillmore of Thermotec UK underfloor heating systems dated 04/03/13

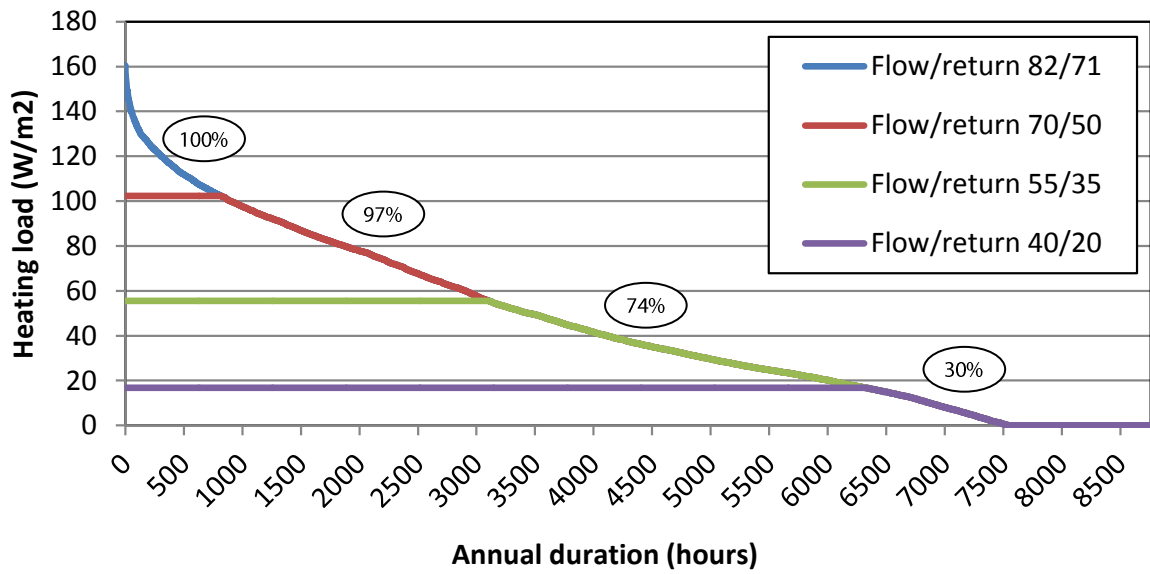

Figure 3-6 – Annual heat demand percentage met by heat supply temperatures – residential low build quality

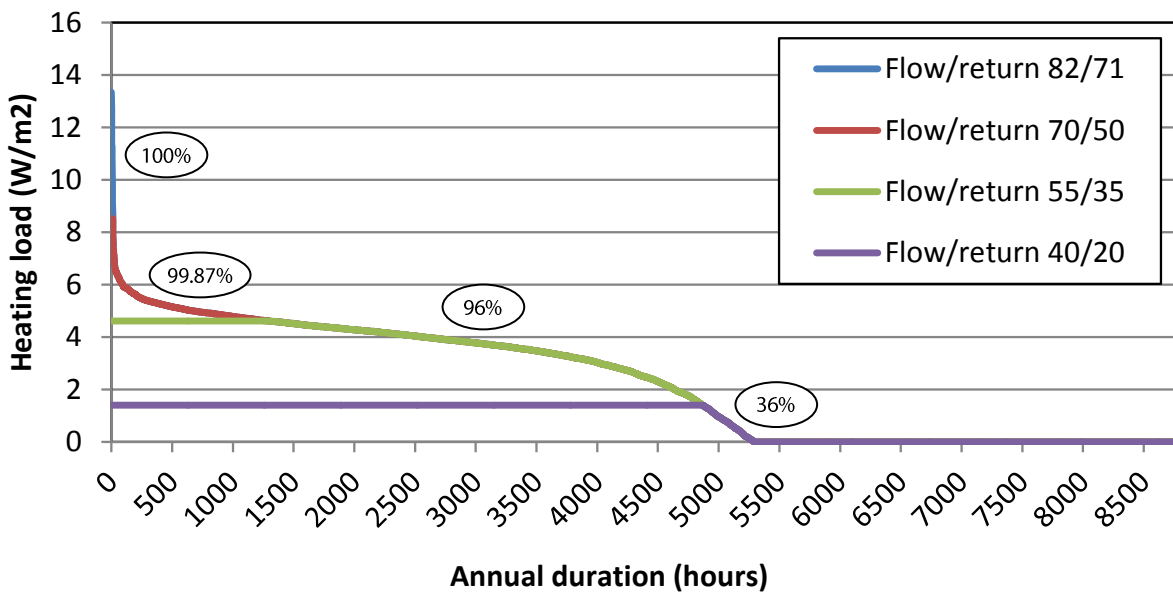

Figure 3-7 – Annual heat demand percentage met by heat supply temperatures – non-residential high build quality

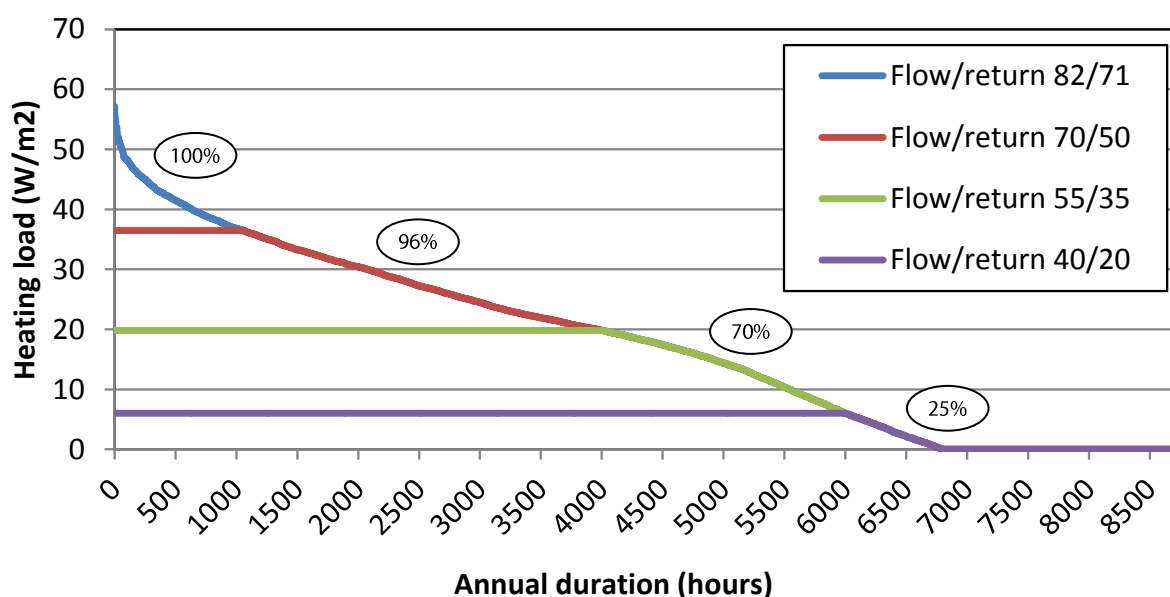

Figure 3-8 – Annual heat demand percentage met by heat supply temperatures –non-residential low build quality

The shape of the load profile in each case determines the proportion of total heat load that may be supplied by a certain lower temperature heat source. For example in the case of the high quality non-residential building (Figure 3-7), the highest loads occur for a very short period of the year, with the rest of the year experiencing a much steadier and lower load. Based on the assumption that systems have been sized to meet these rare peak loads, in this case all the annual heating demand can be met by flow and return temperatures of 70/50°C. Furthermore 96% could be met with flow and return temperatures of 55/35°C. This general pattern may be seen in all the graphs, although not to the same extent.

The figures above display similar percentages across the range of build qualities presented. This is because the percentages refer to the *proportion* of the heat load in each particular building that would be covered by district heat schemes of the stated temperatures. At flow and return temperatures of 82 and 71°C, all buildings will cover 100% of their load since it is assumed that all systems are sized to these temperatures. When the flow and return temperatures fall, whether the building has a very well performing fabric or not, the output of the heating system will also correspondingly fall. This change is a similar *proportion* of the load for each building type.

In *absolute*, rather than relative terms, there is a large variation in the heat loads covered across the range of building quality as can be seen by reviewing the y-axis scale of each of the graphs.

What is clear is that the highest heating loads, that is, those that can only be covered by heating systems supplying and returning water at 82/71°C, occur for a relatively short time over the year. The proportion of heating load that can only be met by this high temperature supply is even smaller. The vast majority of the heating load for these buildings (96% minimum) could be covered by a supply/return at 70/50°C. The majority (70% minimum) could be covered by supply/return at 55/35°C. The lowest temperature examined 40/20°C could only supply a much smaller proportion of the heating load if current systems and buildings were not upgraded.

District heating schemes serving buildings with similar load profiles to those modelled could successfully make use of lower temperature heat sources, with a minimum flow temperature of 55°C, if the temperature could be boosted by a higher temperature source, either locally or

centrally, at times of peak heating load. Recent studies by National Grid Gas¹⁸ have suggested that a similar approach may be adopted with electric air-source heat pumps, where an alternative source, such as natural gas, is used to provide heat under peak 'design load' conditions.

3.3.3 Impact of altering building efficiency

In order to meet a greater proportion of peak and annual heating load, improvements to building fabric are required. Using the energy models developed for the previous section it is possible to quantify this, using ratings derived from SAP models and energy use indicators as proxies for fabric efficiencies (for residential and non-residential buildings respectively).

3.3.3.1 Base case

The proportions of total heat load that could be covered by the various flow and return temperatures, for each building type, can be mapped onto EPC ratings and overall energy use ratings for the residential and non-residential cases, respectively. These results then act as markers, allowing the remaining ratings columns to be filled by linear interpolation and extrapolation. These results are presented in

Table 3-2 (residential) and Table 3-3 (non-residential) below.

Table 3-2 – Proportion of annual heat demand which can be met by heat source temperature for radiators sized to meet peak demand at base case flow and return temperatures – residential

EPC class	A	B	C	D	E	F	G
Base case temperature							
Flow/return 81/72 °C	100%	100%	100%	100%	100%	100%	100%
New temperatures							
Flow/return 70/50 °C	97%	97%	97%	97%	97%	96%	96%
Flow/return 55/35 °C	76%	76%	76%	75%	74%	73%	72%
Flow/return 40/20 °C	27%	27%	27%	28%	30%	31%	32%

Table 3-3 - Proportion of annual heat demand which can be met by heat source temperature for radiators sized to meet peak demand at base case flow and return temperatures – non-residential

Heating use (kWh/m ²)	0 - 100	100 - 200	200 - 300	300 - 400	400 - 500
Base case temperature					
Flow/return 81/72 °C	100%	100%	100%	100%	100%
New temperatures					
Flow/return 70/50°C	100%	99%	98%	97%	96%
Flow/return 55/35°C	96%	90%	83%	77%	70%
Flow/return 40/20°C	36%	33%	30%	28%	25%

¹⁸ Redpoint Baringa (2013) Pathways for decarbonising heat: A report for National Grid
http://www.baringa.com/our_point_of_view/item/uk-heat-economics-study-pathways-decarbonising-heat#.UTm8ShxA2ls

3.3.3.2 Improved case

Improving the quality of the fabric of a building reduces its heating load. If the heating system originally installed is assumed to have been accurately sized, by improving the fabric this installed system is then effectively oversized. In the improved case the reduced load profile may be compared with the central heating system operating at a lower temperature. This indicates what proportion of the newly reduced heating load may be covered in the instance of fabric improvement and originally installed central heating system.

In the tables below, the left hand column indicates the original rating of the building, with the percentages indicating the proportion of the heating load that the building could cover if its fabric were upgraded to the rating indicated in each of the subsequent columns. EPC Class C is considered the highest fabric efficiency standard beyond which lower carbon supply systems are required to achieve A and B ratings.

Table 3-4 – Percentage of annual heat demand which can be met for a given fabric efficiency after retrofit – supply temperature 70/50 °C (LT Type A heat network) – residential

Building fabric energy performance before upgrade (EPC class)	Building fabric energy performance after upgrade (EPC class)			
	C	D	E	F
D	100%	-	-	-
E	100%	100%	-	-
F	100%	100%	100%	-
G	100%	100%	100%	99.9%

Table 3-5 – Percentage of annual heat demand which can be met for a given fabric efficiency after retrofit – supply temperature 55/35 °C (LT Type B heat network) – residential

Building fabric energy performance before upgrade (EPC class)	Building fabric energy performance after upgrade (EPC class)			
	C	D	E	F
D	100%	-	-	-
E	100%	96%	-	-
F	100%	100%	93%	-
G	100%	100%	99%	87.3%

Table 3-6 – Percentage of annual heat demand which can be met for a given fabric efficiency after retrofit – supply temperature 40/20 °C (LT Type C heat network) – residential

Building fabric energy performance before upgrade (EPC class)	Building fabric energy performance after upgrade (EPC class)			
	C	D	E	F
D	81%	-	-	-
E	98%	46%	-	-
F	100%	66%	44%	-
G	100%	81%	56%	39%

Table 3-7 – Percentage of annual heat demand which can be met for a given fabric efficiency after retrofit – supply temperature 70/50 °C (LT Type A heat network) – non-residential

Building fabric energy performance before upgrade (total energy demand kWh/m ²)	Building fabric energy performance after upgrade (total energy demand kWh/m ²)			
	0 - 100	100 - 200	200 - 300	300 - 400
100 - 200	100%	-	-	-
200 - 300	100%	100%	-	-
300 - 400	100%	100%	100%	-
400 - 500	100%	100%	100%	99.7%

Table 3-8 – Percentage of annual heat demand which can be met for a given fabric efficiency after retrofit – supply temperature 55/35 °C (LT Type B heat network) – non-residential

Building fabric energy performance before upgrade (total energy demand kWh/m ²)	Building fabric energy performance after upgrade (total energy demand kWh/m ²)			
	0 - 100	100 - 200	200 - 300	300 - 400
100 - 200	100%	-	-	-
200 - 300	100%	95%	-	-
300 - 400	100%	100%	87%	-
400 - 500	100%	100%	95%	82.3%

Table 3-9 – Percentage of annual heat demand which can be met for a given fabric efficiency after retrofit – supply temperature 40/20 °C (LT Type C heat network) – non-residential

Building fabric energy performance before upgrade (total energy demand kWh/m ²)	Building fabric energy performance after upgrade (total energy demand kWh/m ²)			
	0 - 100	100 - 200	200 - 300	300 - 400
100 - 200	63%	-	-	-
200 - 300	86%	41%	-	-
300 - 400	97%	51%	34%	-
400 - 500	100%	61%	41%	31%

In these tables a C rated residential building and above constitutes a thermal efficiency roughly comparable with the proposed Fabric Energy Efficiency Standard (FEES) as defined by the Zero Carbon Hub. E rated buildings correspond to solid wall, single glazed constructions. The non-residential buildings with annual energy demand of 0 – 100 kWh/m² are similar to a FEES standard in construction and, with annual energy demand of 400 – 500 kWh/m², to solid wall single glazed construction.

To upgrade a building from single-glazed, solid-wall construction to the highest standard of fabric efficiency is likely to be prohibitively expensive. It is more likely that upgrades correspond to moving one or two places up the relevant energy performance class. However, these more modest fabric upgrades can still lead to the great majority of the load being covered by sources with LT Type B (flow temperatures down to 55°C) (see orange lines in Figure 3-9 and Figure 3-10). LT Type C systems (flow and 40°C) still leave a significant portion of the load unmet even with fabric improvements.

Making incremental thermal efficiency upgrades to the fabric of current buildings (i.e. transforming F rated buildings to E rated buildings) could allow low temperature sources to meet almost all heating demand. At peak load conditions flow temperatures of more than 55 °C can be generated, either centrally, or by using existing heating systems to ‘peak lop’. This would enable use of secondary heat, meet heat demands and reduce the carbon intensity of heat supply as the very limited number of hours where the peak lopping was required would not significantly increase the carbon intensity of the heat.

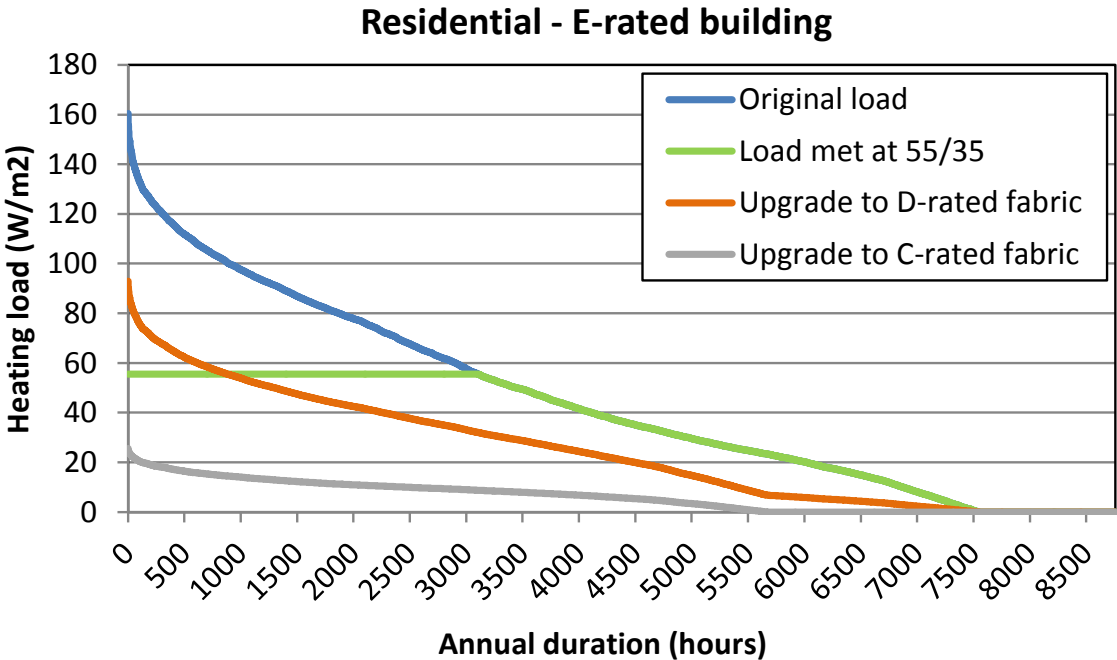

Figure 3-9 – Impact on load duration curve of upgrading the fabric of a poor quality building by one rating (orange line) and by two ratings (grey line) - residential

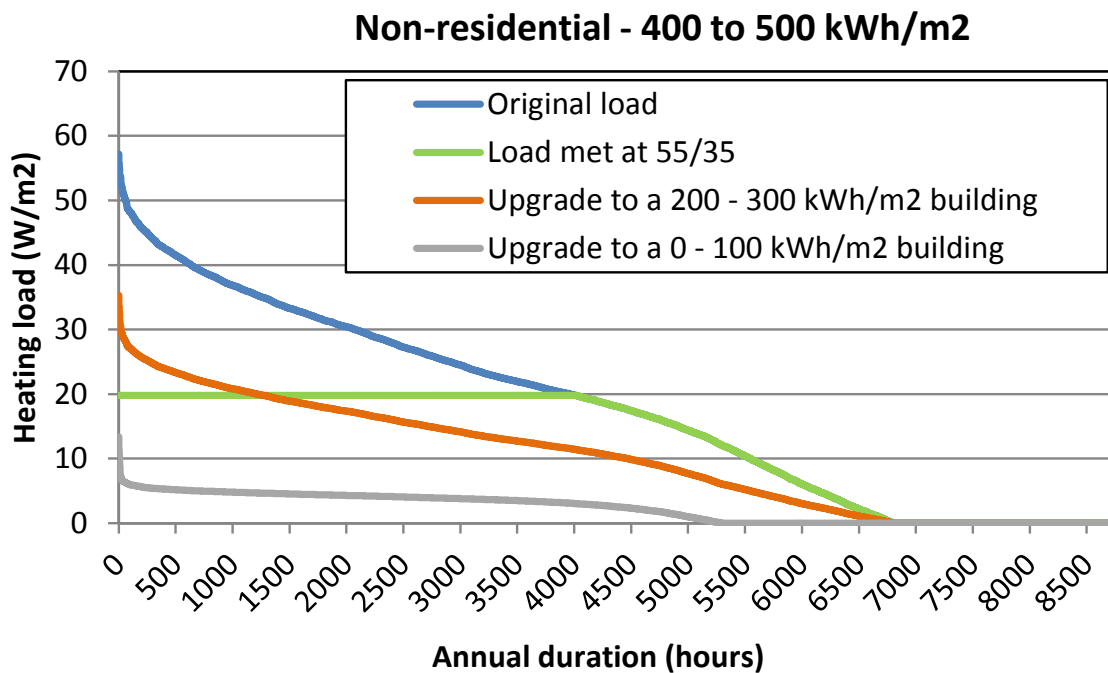

Figure 3-10 – Impact on load duration curve of upgrading the fabric of a poor quality building by one rating (orange line) and by two ratings (grey line) – non-residential

Buildings present in the current London stock have varying quantities of thermal mass. The presence of thermal mass will cause a building to be less reactive to its heating system – in other words it will take longer to heat up and cool down than an equivalent building with less thermal mass. This has to be accounted for in the operation of central heating systems. Buildings with more thermal mass will require their heating systems to engage earlier in the day if they are to be sufficiently warm during the active or occupied period. If all heating systems were appropriately controlled, the variation in thermal mass would become apparent in a district heating scheme by a spreading out of the time in which buildings start and stop demanding heat from the network. Further work is required to understand the impact of thermal mass in detailed terms, however in steady-state conditions at the design temperature it may not significantly impact peak load.

Lower temperature heat systems have a lower instantaneous heat output and so consideration of how they are controlled needs to allow for potentially longer ‘warm-up’ periods and balance the impact of thermal mass. Using programmable room thermostats can help manage this. Intelligent controllers which ‘learn’ the characteristics of the heating system could also manage this. This is an important area to understand as there is strong evidence to suggest many users of heating controls do not understand them, as they are often complex and poorly designed¹⁹. Thermostatic radiator valves which have their temperature sensors in the room air return to the radiator or in the building fabric, rather than on the radiator return, could also help to this.

¹⁹ Coombe, N. et al (2011) ENABLING SUSTAINABLE USER INTERACTION WITH DOMESTIC HEATING CONTROLS <http://bura.brunel.ac.uk/bitstream/2438/6061/2/Fulltext.pdf>

3.4 Conclusions

There are a range of implications of connecting buildings to low temperature heat networks. This chapter has explored the interplay between building fabric and internal heating systems by modelling a selection of 'typical' residential and non-residential building types. Clearly, there are a huge range of such types within London. Some of the conclusions drawn from the modelled cases can be considered to have relevance to the building stock as a whole, however it should be noted that some need to be interpreted in relation to specific building types as necessary:

- Low temperature district heating sources with minimum flow temperatures of 55°C could be used to supply at least 70% of the total heating load of the building types modelled.
- The remaining higher grade heat required to cover the full heat demand at peak times could be supplied either locally or centrally. Given that network construction of systems for the low temperature and conventional district heating systems is likely to be similar, the centralised option would appear to be optimal from an operational perspective. This would also allow for the removal of heating supply plant from buildings. Alternatively the use of existing boiler plant at the point of use would allow a bivalent system to be used, with low temperature sources used for the majority of the year and local plant running on natural gas providing peak lopping. The latter approach may allow for a reduction in pipe size within the heat network, reducing capital cost and heat loss. However, it does increase operational complexity.
- Improving the fabric of buildings by aiming to increase their EPC ratings by a single grade, in the case of residential buildings, or around 100 kWh/m² total energy use, in the case of non-residential buildings, would allow a large proportion (or the whole load) to be covered by low temperature heat sources. This is based on the assumption that the original central heating system which would have been designed to cover a higher heat load than the upgraded building experiences.
- The requirements for peak lopping plant would gradually be phased out as building fabrics were improved. This would allow the heat network to be constructed with the lowest cost, whilst eventually eliminating the increased complexity of a bivalent system.
- Low temperature sources with flow temperatures of around 40°C would require much greater fabric improvements to be made in order to cover a significant proportion of the heating load. This is unlikely to be feasible due to the increasing marginal cost of energy savings at higher levels of retrofit. Low carbon heat supply costs may exhibit lower marginal costs, meaning there is a point beyond which retrofit is not the most cost effective method of saving carbon or supplying energy²⁰.
- The more thermally efficient buildings significantly reduce peak heat demand, as well as consumption. They also flatten the heating duration curve, meaning that systems can operate with more efficient base load plant, and secondary sources can supply a greater proportion of demand.

²⁰ On the basis that negative energy demand = energy supply

- Upgrading building fabric to connect to a lower temperature system is likely to require different heating system operation from that which occupants are used to. Implications of this need to be considered when any upgrades are made.

As noted in the preceding chapter, strategies to improve the viability of utilisation of low temperature heat sources could focus on improving end user systems and building fabric so that they can make better use of lower grade sources of heat. This would require less input from heat pumps and consequently would be less sensitive to energy prices and grid carbon factors going forward.

4 Heat connections: secondary side systems

4.1 Overview

This section considers the design of secondary heating systems connected to low temperature heat networks. It is split as follows:

- Approaches for building secondary system design
 - Terminal design
 - Circuit design
- Case study examples of secondary heating systems connected to heat networks.

4.1.1 References

Research into district heating connections has received significant attention through the International Energy Agency (IEA) *Implementing Agreement on District Heating and Cooling including the integration of Combined Heat and Power*²¹. A number of annexes, the latest being Annex X, have been run each over a period of around three years, covering a variety of research topics. Those most relevant to connections for low temperature sources in district heating are:

- Annex VI: District Heating and Cooling Building Connection Handbooks²²
- Annex VIII: District heating distribution in areas with low heat demand density²³
- Annex X: Towards 4th Generation DH: Experiences with and Potential of Low Temperature DH (complete by 2014)²⁴

The following sections draw heavily on first two of these references. When the third reference is completed this will form an important source of knowledge regarding the operation of low temperature systems which is covered in Section District energy sharing 6.4.6 of this report. Reference has also been made to connection requirements from various district heating operators reflecting recent project experience.

²¹ IEA (2013) Home page of Implementing Agreement on District Heating and Cooling including the integration of Combined Heat and Power <http://www.iea-dhc.org/home.html>

²² IEA (2002) District Heating and Cooling Building Connection Handbooks <http://iea-dhc.org/dhc-research/annexes/1999-2002-annex-vi/annex-vi-project-06.html>

²³ IEA (2008) District heating distribution in areas with low heat demand density <http://iea-dhc.org/dhc-research/annexes/2005-2008-annex-viii/annex-viii-project-03.html>

²⁴ IEA (2013) Towards 4th Generation DH: Experiences with and Potential of Low Temperature DH <http://iea-dhc.org/dhc-research/annexes/2011-2014-annex-x/annex-x-project-03.html>

4.2 Approaches for secondary system design

For the purposes of this report, the term ‘secondary system’ design is used to refer to all elements within the building that enable it to utilise heat from a district system. Two aspects of secondary system design are considered in particular, the terminal design and controls and the secondary circuit design.

The following sections set out a recommended approach for connections to low temperature heat networks, however, in practice these principles should also be followed for connections to all district heating systems.

4.2.1 Recommendations for terminal design and controls

The design of the final heating systems and the control of that system is important for effective utilisation of lower temperature heat sources, and particularly for ensuring low return temperatures to the heat network. Key design issues and their pros and cons are outlined in Table 4-1 below. Figure 4-1 shows the principle of 2-port control, referred to in Table 4-1. The regulator can also be placed in the return air to the terminal device (e.g. a radiator or fan coil unit) to sense when additional heat is required in the space.

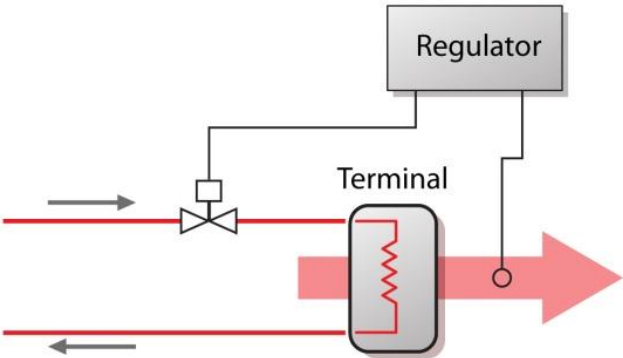

Figure 4-1 – Principle of two port control for terminal devices

Table 4-1 – Recommendations for design of building heating systems for connections to low temperature heat networks

Principle	Description	Advantages	Disadvantages
2-port control	2-port control regulates flow to control heat output (see)	Using 2-port control ensures heating water passes through heat emitters at only the rate required to heat the space. This means that heating water is cooled as much as possible, reducing the return temperature. This is as opposed to 3-port control where a significant part of the heating water flow bypasses the heat emitters returning at close to the flow temperature.	Bypasses are sometimes required to maintain temperatures on main branches of heating systems with low demand. However, these should be minimised and use temperature controlled bypass valves.
Underfloor heating	Central heating system	Operating temperatures are typically around 30 – 45°C and so well suited to low temperature supply without the need for extensive modifications.	Delayed response time and low flow temperatures may not suit all occupants and building types. Output typically limited to 60W/m ² Requiring a relatively efficient building fabric
TRVs	Thermostatic radiator valves	Valves automatically control the temperature of the room by changing the flow to the radiator. Temperature is based on user control	TRVs are less discreet than manual radiator valves and do not allow as much user control as programmable thermostats
Programmable room thermostats	Dynamic control of room temperatures	Allows heating for individual rooms to be restricted to certain periods and temperatures to reduce heat wastage and to avoid overheating	Room thermostats usually control boiler operations, this level of functionality is also available from a district network.
Weather compensation controls	Adjusts the flow temperature based on ambient temperature	The network and systems can be operated at lower temperatures allowing lower temperature sources to be used. Only on cold days are flow temperatures increased. Can be effectively combined with TRVs to ensure low return flow temperatures	Temperatures need to be increased either locally or centrally to meet peak loads. For former additional plant is required, for latter network must be designed to meet this requirement (e.g. higher grade materials)
Large Radiators	Larger radiators sized to meet heat demand with lower flow temperature	Relatively easily retrofitted to allow low temperature heat supply to conventional buildings	Increased capital costs due to need to replace radiators. Restrictions in space and increased visual impact of large radiators

Principle	Description	Advantages	Disadvantages
Use of hot water storage tank (calorifier)	Local hot water storage in a calorifier (tank)	<p>Reduces peak load on the heat network, allowing pipe sizes to be minimised</p> <p>Hot water supply is more resilient to heat network failure as typically 0.5-1 day storage provided and an auxiliary heating source can be provided (e.g. electric immersion heater)</p> <p>Easy to integrate with solar water heating</p>	<p>Tend to result in high return temperatures as most water in the tank is at around 60°C. Return water cooling of as little as 5°C possible</p> <p>Standing losses from calorifier</p> <p>Space take - in many cases people have removed hot water tanks and for new build unlikely that additional space take is welcome</p>
Use of plate heat exchangers for hot water provision	Plate heat exchangers are used to generate domestic hot water 'on-demand' drawing heat from the secondary heating network	<p>Instantaneous hot water performance, which does not run out, similar to a natural gas combi-boiler. Also delivers mains pressure water for showers etc.</p> <p>Low space take</p> <p>Excellent cooling of return water (down to 15-20°C)</p>	<p>Large instantaneous demands means plant and pipework have to be sized accordingly</p> <p>No storage and not as resilient as a calorifier based solution</p>
Use of hot water storage tanks with plate heat exchangers	Hot water is stored in a calorifier. When temperature in the calorifier drops below a certain value a small shunt pump draws off water and pumps it through plate heat exchanger connected to the heat network. The hot water enters the calorifier at the top, re-charging the contents	<p>As per use of hot water storage tanks</p> <p>Excellent cooling of return water (down to 15-20°C)</p>	<p>Standing losses from calorifier</p> <p>Space take - in many cases people have removed hot water tanks and for new build unlikely that additional space take is welcome</p>

4.2.2 Recommendations for circuit design

The second critical factor is the circuit design, linking the external network to the end use heating system. Table 4-2 sets out the recommended design approach for connection to lower temperature heat networks. Figure 4-2 shows the recommended configuration of a secondary heating system for connection to a district network. This includes the use of true variable flow pumping whereby flow can be reduced to very low (almost zero) levels during low load conditions. Low loss headers and primary circuits with separate pumping are avoided due to the large bypass flows which pass to the return of the primary heat network side.

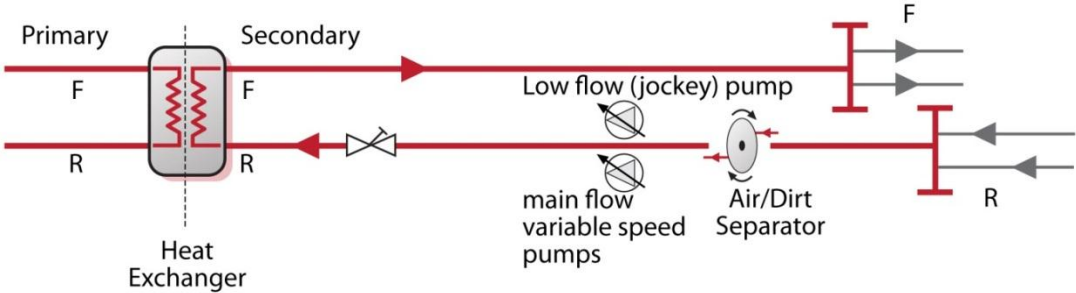

Figure 4-2 – Principle of recommended approach for secondary side heating system design to minimise heat network return temperatures

Table 4-2 – Recommendations for design of building heating systems for connections to low temperature heat networks

Principle	Description	Advantages	Disadvantages
Variable speed pumping	<p>Use of pumps which operate at variable speed and are controlled to maintain a fixed minimum differential pressure at a reference point (the index point or longest run or across control valves at terminal units) on the secondary heating system side.</p> <p>Terminal units make use of 2-port control approaches.</p>	<p>Variable speed pumping ensures that return temperatures are kept to a minimum even when low loads are present at the district heating connection.</p> <p>Significant energy savings can be achieved compared to constant speed pumping. The savings are most marked during low load conditions, when even small reductions in pump speed provide significant energy savings²⁵.</p> <p>There is some evidence to suggest that throttling flow may be a more effective way of reducing return temperatures than using temperature compensation however practical evidence was not available.</p>	<p>Controls and system commissioning of secondary systems may be considered more complex. However, variable speed pumping is considered common practice in building heating system design²⁶.</p> <p>Check (non-return) valves should be used to prevent reverse flow in low flow conditions.</p>
Use of direct connections	<p>Building connections should not use a heat exchanger, with space heating being provided via direct connection</p>	<p>Direct connections minimise costs and enable the lowest possible supply temperatures to be used.</p> <p>They are most appropriately used on smaller scale heat networks where pressures are lower (<6bar) and building systems can be designed to accommodate the operating pressure in the network</p> <p>Leakage concerns can be addressed through use of automatic leak detection valves on flow and return.</p>	<p>They are not suitable for connections to taller buildings due to static pressure, or in areas with large variations in topography</p> <p>They should only be used provided heating system on secondary and primary side are both in good condition</p> <p>They potentially raise the possibility of disputes between system owners where poor water quality causes performance issues</p>

²⁵ Modern Building Services (2008) Realising the energy-saving benefits of variable-speed pumps: http://www.modbs.co.uk/news/archivestory.php/aid/5516/_65279;Realising_the_energy-saving_benefits_of_variable-speed_pumps.html

²⁶ CIBSE (2006) KS07 Variable Flow Pipework Systems (CIBSE Knowledge Series KS7) https://www.cibseknowledgeportal.co.uk/component/dynamicdatabase/?layout=publication&revision_id=112

Principle	Description	Advantages	Disadvantages
One circuit	<p>Heating systems should be comprised of one circuit without use of separate primary and secondary circuits.</p> <p>No use of low loss headers.</p>	<p>Using a single circuit means that heating water passes through the full heating system, maximising the opportunities to cool the water, reducing return temperature.</p> <p>Costs are lower as there is less fluid circulating and fewer pumps in the system.</p> <p>Using low loss headers means a significant portion of the flow in the primary circuit does not go through the terminal units and so is not cooled. This approach is widely used with gas boilers where maintaining flow through the heating appliance is important but is not suitable for use with district heating systems.</p> <p>Where headers are used isolators should be included to allow a single circuit to be created.</p>	<p>Building system designers may not be familiar with this approach.</p> <p>The control of pressure within heating systems may be considered more complex, though this is not the case in practice.</p>
Multi-stage pumping	<p>Use multiple pumps in parallel to give good variation of flow over the whole range of load conditions.</p> <p>This could include use of very small capacity 'jockey' pump for low load conditions (e.g. where domestic hot water load is the only requirement).</p>	<p>Variable speed pumps are not able to turn down to zero, and so where there are large variations in heat demand (e.g. peak winter space heating load vs. summer hot water load) a single set of variable speed pumps may not provide adequate turn down to provide good cooling of return water.</p> <p>A pump selection of several pumps in parallel including a jockey pump should be used to give good turndown performance, down to a few per cent of peak load demand.</p> <p>Further energy savings are possible as motor efficiency is reduced on pumps operating at high turndown ratios. By having a smaller pump and motor operating closer to their full load, efficiencies are greater and energy savings are maximised.</p>	<p>More pumps are required potentially adding some additional capital cost</p> <p>Control of the pumps needs to be undertaken by a building management system or pump controller but these are commonly found in most modern building services systems.</p>
Plate heat exchanger sizing	<p>Plate heat exchangers sized to give good approach temperatures and controlled with differential pressure control valves.</p>	<p>Using correctly sized plate heat exchangers means that close approach temperatures can occur (e.g. return temperatures on the primary side can approach the return temperature on the secondary side), maximising the cooling of the district heating return water.</p>	<p>None.</p>

Principle	Description	Advantages	Disadvantages
Strainers	<p>Where plate heat exchanger used strainers should be used to protect the heat exchanger.</p> <p>A flushing loop should be installed on the secondary side to bypass the heat exchanger.</p>	<p>Plate heat exchangers have relatively small clearances and can become partially or fully blocked by debris. This is particularly true where new buildings are connected without adequate system flushing, or where old buildings with dirty systems are connected to heat exchangers.</p>	<p>Pressure drop across the strainer marginally increases pumping energy.</p>
Pumps on return leg of heating circuit	<p>The secondary system pumps should be installed on the return of the heating circuit, prior to the heat exchanger / connection point.</p>	<p>This arrangement reduces cavitation on the pump, though this should not be a problem for low temperature systems.</p>	<p>None.</p>
Connect circuits in series	<p>High temperature circuits such as radiators and calorifiers should be connected in series with lower temperature requirements such as underfloor heating.</p> <p>The return from the higher temperature system becomes the flow to the lower temperature system, maximising the cooling of the heating water.</p> <p>The return water from space heating can be used to pre-heat the domestic hot water supply, by using a pre-heat heat exchanger (also termed a 2-stage connection)²⁷.</p>	<p>Increases cooling of the heating water, further reducing return temperature.</p>	<p>Not always possible where one circuit demands heat at a different time from others.</p> <p>Increase in complexity may not be suitable for smaller consumers or connections where domestic hot water is not a significant load.</p>

²⁷ Svensk Fjärrvarme (2004) District heating substations: design and installation, technical requirements F101, p35: http://www.chpa.co.uk/medialibrary/2011/04/07/9117396d/CHPA0007%20F101_District_heating_substation_design.pdf

4.3 Case study examples of recent practice

Following recent experience of district heating projects a list of common issues that cause poor performance of building connections has been compiled. Five large buildings connected to a district heating system were reviewed, and the following common faults identified:

- Low loss headers and primary pumping used
- 3-port control used
- Combination of three port control on secondary circuit and low loss header
- Pump not installed on return leg

The following section summarises the approaches taken and their impact on the performance of the system’s ability to return district heating water. The system in question would suffer from an overall 40-60% reduction in effective capacity due to the high return temperatures across the system.

4.3.1.1 Low loss headers and primary pumping

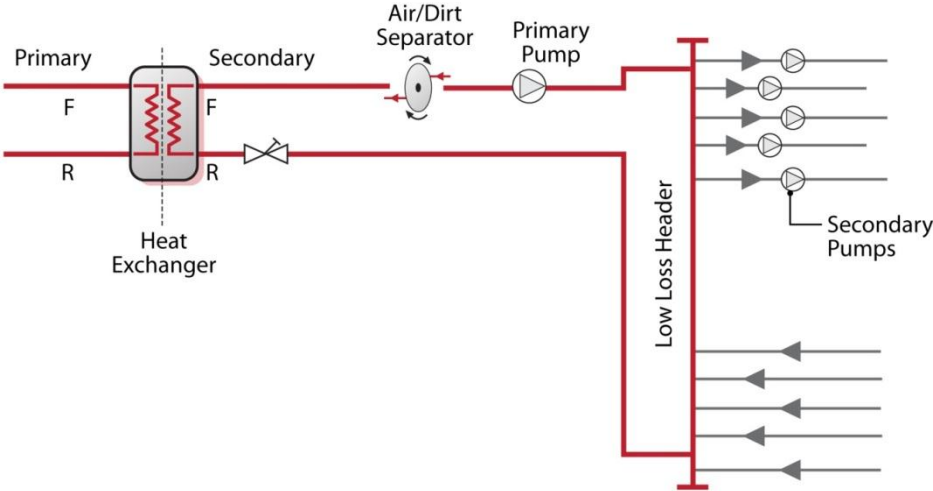

Figure 4-3 - Example of use of low loss header with primary pump circuit

Description	Resulting temperature differential	Improvements
The secondary heating system is formed of two circuits (LTHW primary and secondary circuits) with the flow in the LTHW primary circuit generally much greater than the secondary circuits. This means that water is returned to the heat exchanger without being cooled.	15°C (5°C without swimming pool)	This approach could be improved by following best practice, as well as using the return water from domestic hot water and space heating to provide pool heating when available.

The example shown was not as poor as it might have been as, despite not following best practice design, the system was serving a swimming pool which resulted in reasonable cooling of return water, even at lower loads. A similar example in a non-swimming pool building provided only 5°C cooling of the primary side district heating water, showing the importance of following best practice.

4.3.1.2 3-port control at plant room

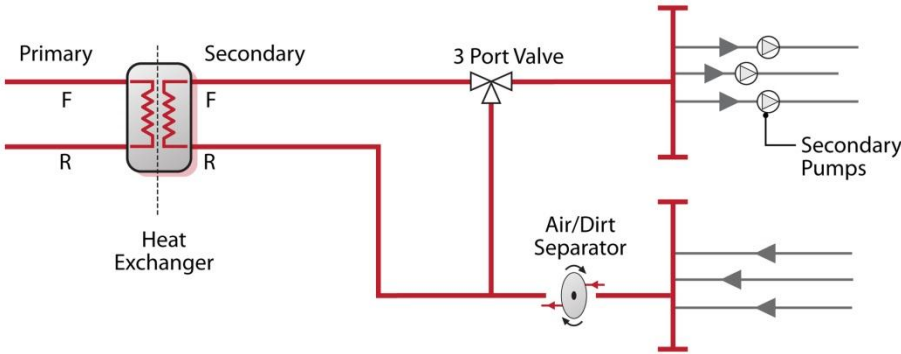

Figure 4-4 – Example of use of 3-port control to bypass heat load and increase return temperatures

Description	Resulting temperature differential	Improvements
A 3-port mixing valve is included in the circuit across the heat exchanger.	15 °C	<p>Removing the mixing valve and relying on better volume (speed) control of pumping would be more effective.</p> <p>Using a single set of pumps in parallel including a jockey pump, rather than a series of secondary circuit pumps would give this volume control.</p>

The intention of this approach is to divert flow water back into the supply circuits, effectively recycling it where the return temperature is too high. Whilst the intention is to reduce the return temperature this is not as effective as good speed control of pumps down to a few per cent of full load flow.

In this scenario there is also a risk of the flow temperature being reduced below the required temperature for one of the secondary circuits. If there is a hot water storage vessel on the secondary circuit this temperature could be reduced further. This could cause an increased legionella risk if, for example, the hot water system has been design for a flow temperature of 60°C

4.3.1.3 Combination of three port control on secondary circuit and low loss header

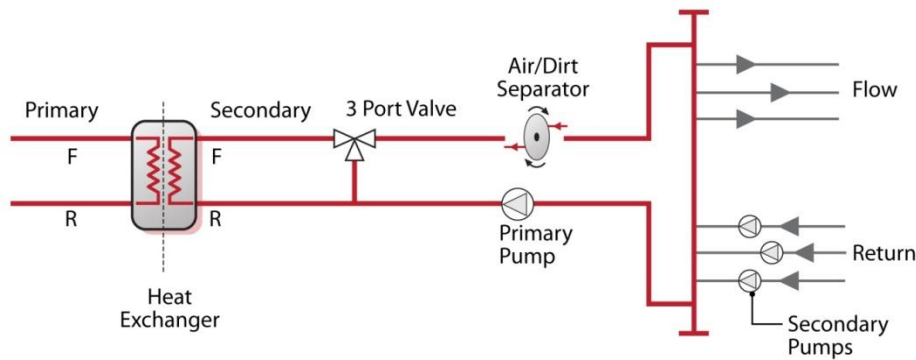

Figure 4-5 – Example of use of three port control along with a low loss header

Description	Resulting temperature differential	Improvements
Separate primary and secondary pumping circuits have been included, along with a 3-port mixing valve which allows the return water to be diverted back into the flow	10 °C	Use of a single circuits rather than separate primary and secondary circuits Improved volume control at low loads rather than use of 3-port valve to try to 'recycle' return water

A low temperature differential occurs due to the use of a low loss header and 3-port mixing between flow and return on the secondary side. This is similar to the previous example.

4.3.1.4 Pump not installed on return leg

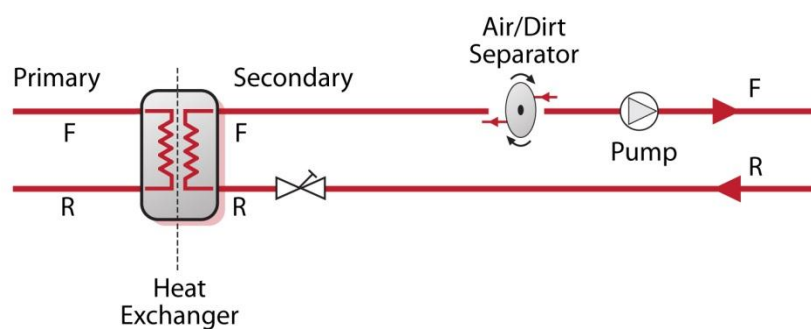

Figure 4-6 - Pump not installed on return leg to heat exchanger

Description	Resulting temperature differential	Improvements
This system is almost entirely designed as per the recommendations	20-25 °C	Installing the pumps on the return side of the circuit means they operate at lower temperatures and may prolong their operating lifetime

This circuit achieves a good temperature differential and most of the recommendations are implemented. The life of the pump could be enhanced by including pumping on the return leg of the circuit. Additionally return temperature could be further reduced by enhancing variable volume turn down on the pumping circuit by installing a jockey pump in parallel with the main pumps for very low loads.

4.3.1.5 Use of hot water storage tanks at high temperatures

In this example a large new apartment block complex was constructed without considering the cooling of return water to the heat network during low load periods where the highest load is from domestic hot water. In many new residential developments hot water is the dominant requirement for heat.

Description	Resulting temperature differential	Improvements
<p>A heat network was connected to a secondary network operating at around 85°C. Local hot water storage was used within apartments to generate domestic hot water. This resulted in good spreading of demand over the day, but gave very poor return water temperature. Losses in the secondary system are also expected to be high.</p> <p>As the heating coils in the calorifiers were designed to operate at a high temperature it is not possible to reduce the supply temperature without increasing hot water recharge periods</p>	5-10°C	The use of a small plate heat exchanger to recharge the hot water tank rather than an internal coil would allow a lower network temperature to be introduced. It would give much low return flow temperatures.

4.4 Conclusions on heat network connections

It is possible to draw some key conclusions from the previous sections. These include:

- Many buildings connected to heat networks in the UK do not provide adequate cooling of the return water. This restricts the ability of low temperature sources to contribute to the heat supply.
- Best practice guidance for heat network connections typically refers to the design of the heat exchanger, metering and associated requirements for on-going access and maintenance (e.g. strainers to protect the heat exchanger, flushing bypasses, metering points etc.)
- Whilst some heat network operators provide guidance on the design of building side systems further guidance and education of designers is required to ensure systems achieve high temperature differentials. Publications such as Good Practice Guide 234 and CIBSE Guide AM12 could address this issue in more detail.
- A key recommendation for low temperature networks is to include a strong incentive on connected consumers to maintain the lowest possible return temperatures. This could be achieved through penalty charges for high return temperatures, or by metering for volumetric usage as well as energy content. These approaches could be combined, with the former acting to provide a minimum performance level and the latter providing an incentive for lower charges. An alternative would be volume only metering, though this may result in punitive bills in some cases.
- Intelligent controls such as programmable room thermostats and weather compensation controls help increase efficiency by reducing the risk of overheating in buildings. However, they must be designed to be easily understood by consumers! Perhaps more importantly for heat networks the use of TRVs, room thermostats and the careful selection of hot water generation systems ensure good cooling of return water to the heat network.
- In order to take advantage of low temperature networks designing heat networks to ensure low return water temperatures is critical. More consideration of this issue is required for both new build projects and for the retrofit of heat networks to existing systems.

5 System operation

5.1 Overview

The following section addresses some of the key system issues arising on connecting low temperature heat sources to higher temperature networks²⁸. It also addresses design issues that could be taken into account to enable new networks to be operated at lower temperatures in future. This section is largely qualitative based on answering a number of key questions.

5.2 Connection to higher temperature networks

Indirect v direct connection

A low temperature source can in theory be integrated into a high temperature network. The heat is usually upgraded to the same temperature at which the network is running. For projects using waste heat from industrial processes, this is usually done by way of a heat pump. A low temperature source feeding directly into a high temperature network will cool the temperature in that part of the network. The amount of cooling will depend on the amount of water fed into the network and what temperature it is at. Unless this cooling is an intended part of the design operational characteristics of the plant and is tightly controlled, it is unlikely to be a desirable situation.

Networks can be split into a number of areas at different temperatures. This is already a common situation where there are high temperature transmission mains and then a lower temperature network to provide heat to the end users (LT Type A). In some cases where there are new developments of energy efficient buildings, the network temperature is further reduced to a very low temperature network (LT Type B).

The interface between areas of different temperature typically has a heat exchanger and mixing station on the lower temperature side to ensure the correct flow temperature. The mixing station will take water from the return of the lower temperature system to mix the flow temperature to the required temperature.

Connection of lower temperatures sources to the return leg of DH pipe work

It may be possible to connect low temperature sources to the return leg of the district heating mains, depending on the primary heat production plant. If the primary plant is capable of receiving return water at a high temperature (for example boiler plant) without losing efficiency, then connection of a low temperature source to the return leg can be completed without loss of efficiency.

A CHP unit will require a return temperature as low as possible. Therefore, if a CHP unit is used as the primary method of heat generation on the network, it is undesirable to connect a heat source to the return leg. This will raise the temperature of the return water and reduce the overall efficiency of the CHP unit.

In theory different temperature heat supply sources can be used within the same network. Appendix D contains a review of proposals to use this approach for a project in Bunhill, Islington. A

²⁸ This chapter is based on input from COWI, Denmark, based on practical experience.

review of the proposals suggests that while this may be possible in theory, in practice the small size of the system means that the location of the change in temperature in the network could change significantly as heat demands from different buildings turn on and off. This means the system could be unstable, making it difficult to maintain required temperatures at different locations in the network. To enable operation of this system without using hydraulic separation a detailed study of the location of the 'neutral' point within the system is required. If this is found to be stable under a range of conditions (e.g. sudden heat demand from a large consumer) then using different temperatures in the same network is possible. This approach is more common in large heat networks where the diversity of load between thousands of consumers makes the networks more stable, allowing the connection of multiple sources at different temperatures.

Adjusting flow temperatures to address seasonal changes in heat demand

It is possible for the flow temperature of the network to be raised during periods of high heat loss. Variation of the flow temperature to match the demand whilst optimising the operation of the system is common and desirable in many large systems. See Section 3 for more details of the implications of changing temperature on an existing system.

Whilst it is usually possible to turn down the temperature in an existing system without damage to the pipes themselves (unlike turning up the temperature, which can cause problems for PE pipe work), the size of the pipes installed must be considered if there is an intention to reduce the flow temperature of the system in the future. A lower flow temperature will mean that larger pipes will be required to transport the required volume of water without increasing the pressure to an unacceptable level. If there is an intention for a lower flow temperature to be used in the future to reduce heat loss and utilise low temperature sources of heat, it may be worth designing the network with this in mind and investing in larger pipes from the outset to future-proof the network.

Dealing with diverse heat sources

The main issue with connection of low temperature sources to a heat network is the diversity of the sources in terms of temperature and ease of collection. Sources must be integrated into the network in such a way as to avoid causing problems elsewhere on the network and to ensure that the heat is adequately utilised.

In many cases it is preferable to upgrade the heat using a heat pump at the source. This ensures that all heat input to the network is at the same temperature. However, a heat pump uses electricity to increase the temperature. Although modern heat pumps are increasingly efficient, the electricity used does increase the carbon emissions associated with the heat unless the heat pump is run using renewable electricity which has been locally generated. For example, the heat pump in Frederikshavn, Denmark has a direct connection to a nearby wind turbine and uses this electricity to power the heat pump²⁹.

If the heat can be utilised at the source temperature without being upgraded the electricity input to a heat pump can be saved. However, larger pipes will be necessary to transport the heat to the point of use which may represent a significant additional capital cost if the heat is to be

²⁹ See Case Study presented in Phase 1 report for this study.

transported over long distances. Increases in pipe sizes could be mitigated by ensuring maximum cooling of district heating return water.

Design guidelines for owners of heat sources

One major issue with the connection of low temperature heat resources is the collection of the heat itself. Most low temperature sources will not have been designed with heat collection in mind. Many of the very low temperature sources, for example ventilation shafts from the Tube will, by the nature of their design, be much dispersed. This can make it difficult to extract the heat.

The design of the heat rejection plant for any heat source will significantly affect the design of the equipment required to collect the heat. In some cases it may be possible to install a heat exchanger to directly collect the heat and distribute to the network, in other cases it may be necessary to upgrade the heat by way of a heat pump before it is put into the network.

Because the parameters of low temperature heat sources vary so much in terms of temperature, density and extraction possibilities it is impossible to give detailed design parameters to assist owners of low temperature systems and encourage connection to a heat network. It is likely that most heat sources will need to be assessed on a case by case basis.

However, if connection to a heat network is desirable in future it is worth considering the possibilities for making that connection when designing a new plant or considering refurbishment of existing equipment. Some key issues that may be considered are:

- Density of heat. Is the heat concentrated in one area where it will be relatively easy to install collection equipment?
- Temperature of heat available. Is it possible to ensure that the temperature is as high as possible in the waste heat stream?
- Impacts of heat extraction on downstream processes. In some cases it may not be desirable to cool the waste stream too much, for example in sewage treatment works where the temperature is important for microbial processes.
- Space and location of heat extraction plant. It is worth considering at the time of construction the type of plant required to extract the heat and to plan space and access for installation accordingly.

5.3 Benefits of using lower temperature sources of heat

Extent of losses

Reducing the flow temperature has a significant effect on the network losses. The lower the flow temperature, the lower the difference in temperature between the flow pipe and the ground, and therefore the slower the heat transfer out of the pipe. Reducing the temperature from 70/55 °C flow/return to 55/30 °C can reduce network heat losses by approximately 38%. Further reduction to flow/return temperatures of 45/25°C can provide an additional saving on network losses of up to 25% (depending on size of pipe and network configuration).

Twin Pipes or Single Pipes

Traditional installations usually use a single pipe system, whereby the flow and return are insulated individually and installed as separate pipes. However, due to the reduction in network heat losses, twin pipes are becoming more and more common for new installations. A twin pipe includes both

the flow and return within a single insulation layer. This results in more effective insulation and therefore reduced network heat losses. See Figure 5-1.



Figure 5-1 – Use of twin pipe system to limit heat losses

The twin pipe system can provide substantial savings on the running costs of the system by significantly reducing network heat losses compared with a single pipe system. Typically between 15-25% of the heat losses from the network can be saved simply by installing a twin pipe system rather than single pipes for new networks.

The twin pipe system requires a slightly smaller trench and therefore has a small saving on the excavation costs. However, the twin pipe itself is slightly more expensive to purchase than two single pipes due to the differences in the manufacturing process. For installation of a new district heating network the costs can be assumed to be broadly comparable. The cost of the twin pipes themselves has risen in the last few years as this system has been utilised more throughout Europe. When new to the market, the twin pipe system was discounted to encourage uptake. However, now its use is more widespread, discounts are no longer so readily available.

PEX³⁰ Pipes for District Heating

For the smaller pipe dimensions and lower operational temperatures there are a number of different options in the pipe design, each with its own advantages and disadvantages:

- PEX pipe is widely used in many general plumbing applications across Europe and, at lower flow temperatures, is suitable for use for district heating supply. The advantages of using PEX are that it is relatively cheap, flexible and quick to fit. However, the material has a tendency to degrade should oxygen enter the system or by the mechanical stresses of expansion and contraction.
- Al-PEX pipe has a number of brand names depending on the manufacturer, for example Logstor's market offering is called AluFlex and Isoplus' is called Alupex. Al-PEX is similar to PEX in that the pipe itself is made from a plastic polymer. However, the pipe is surrounded on the outside by a thin layer of aluminium. This helps to reduce the risk of degradation due to

³⁰ PEX is the common abbreviation of cross-linked polyethylene, a material often used for pipe manufacture.

oxygen entering the pipe. Al-PEX also allows easier installation in some circumstances (particularly where there are bends in the pipe route) as, once bent, it keeps its shape better than PEX (which has a tendency to spring back to a straight length). However, Al-PEX is slightly more expensive than standard PEX to purchase.

- It is also possible to use flexible steel pipes down to very small internal dimensions. These are not used so often for small diameter branch connections to dwellings due to the risk of very fast degradation of the pipe should air or untreated water enter the network (for example from a leak of a heat exchanger from the raw water side to the district heating side).
- The choice of pipe type to meet the requirements of a scheme depends on the temperature parameters on which the network is designed to run. Plastic pipes cannot withstand high temperatures and do not react well to the physical stress of expansion and contraction of a network at high temperature and should therefore only be used if the operational temperatures are low ($\leq 85^{\circ}\text{C}$).
- The most widely used and well tested option is, however, still to use steel pipes for the district heating mains and flexible pipe (either PEX or Al-PEX) for the connections to the dwellings. This allows for ease of installation and access for replacement or maintenance as necessary in the future. The most common type of flexible pipe used in recent projects is Al-PEX³¹.

5.4 Temperature Variation

Temperature variation throughout the year

It is possible and desirable to vary the flow temperature of the district heating to ensure that enough heat is available during periods of high demand. In fact, many district heating systems constantly vary the temperature to ensure that there are the lowest possible network losses whilst there is sufficient heat provided to customers. For example, COWI use TERMI's temperature optimisation on a number of systems. This continuously monitors the demand and adjusts the flow temperature to match, ensuring that the network operation is always optimised and the network losses are always minimised.

When considering temperature variation, the type of installation and the design flow temperatures and pressures must be taken into account. Plastic pipes may be cheaper to install, but may limit the extent to which the temperature can be increased.

An IEA study found that network temperatures can reduce by around 7°C during low demand periods in summer due to heat loss and low flows in the network. At individual connections network temperature was found to drop below 25°C . In areas which have low heat demand density and low network temperatures temperature controlled bypasses should be considered, in order to maintain suitable temperatures at consumer connections³².

Legionella Control

Networks with a low supply temperature can give rise to potential issues of Legionella growth within the hot water systems, particularly where there is a tank. This can be controlled either by

³¹ Based on COWI experience.

³² IEA (2008) District heating distribution in areas with low heat demand density, p14: <http://iea-dhc.org/dhc-research/annexes/2005-2008-annex-viii/annex-viii-project-03.html>

limiting the amount of water held in the system at any one time or preventing the growth of Legionella by heating the water to over 65°C. This issue is also discussed in Section 3.2.

In domestic properties the Legionella issue can be dealt with by limiting the amount of water in the system at any one time and by ensuring that it cools quickly when not in use. In previous projects in Denmark, this has been ensured by designing the system so that there is a maximum water volume of 0.5 litres in the heat exchanger at any one time. Pipe work lengths within the dwelling are limited to ensure that there are less than 3 litres held in the internal hot water system at any one time. Obviously, this solution will only be applicable to new domestic buildings where there can be some influence on the internal design parameters. In the UK this approach would be subject to approval by public health authorities.

The alternative of controlling Legionella growth is to heat the water in the system to 65°C. This may be necessary in some buildings that are to be retrofitted to a district heating system where it is not viable to change the internal hot water system to meet the above requirements.

The extra cost of the additional heating required will depend on the amount of water to be heated and the flow temperature from the district heating system. In some cases an electric coil in the calorifier or hot water tank could provide additional heat as necessary. In other cases (large office buildings or apartment blocks) where there is already a gas connection, a very small (domestic sized) gas boiler could be used to provide the necessary top up. Depending on the hot water use and configuration within the building it may also be possible to install point-of-use heaters for sinks etc. This may be more economical if the use is low and inconsistent than the alternative of holding a large volume of water at or around 60 °C. Hot water systems often account for large losses in non-residential buildings³³.

It should be noted that the above suggestions of additional heat sources to ensure that the Legionella regulations are met in some low temperature systems are only to be used in areas where it is not economically possible to design the system to avoid the issue. An additional electric or gas fired element will not usually contribute to the carbon reductions of the scheme (unless the electricity is generated sustainably, i.e. from local solar panels).

As noted in Section 3.2, chemical dosing is an alternative method of control permitted in the UK. The location of the dosing would be dependent on the property. If it is a block of flats with a shared cold water storage, both the hot and cold systems tanks should be dosed, cost permitting. If they are single dwellings fed direct from the mains, an in-line dosing unit could be fitted to the block of flats or after the 'tee' from the main on a housing estate.

5.5 Changing from one temperature to another

Impacts on capacity

Depending on the installation it may be possible to change the operational temperatures in the future. The main issue when changing the temperature on an existing system is usually around the type and installation of the pipes (which will have been designed for the current operational temperature).

³³ A recent Buro Happold energy audit on a university building found that 2/3 of the gas demand was used in maintaining the water heaters, distribution networks and hot water tanks at temperature - a 100kW demand present 24 hours per day, all year round.

A low temperature network will require larger pipe sizes than traditional operating temperatures as there will be a larger volume of water flowing through the pipes. When considering lowering the temperature of a traditional network, care must be taken to ensure that the pipes are large enough for the new operational regime.

Conversely, when considering a new heat network it is worth considering the proposed connections and how the heat load will change over time. The network itself is expected to last for up to 50 years. Within this time it is reasonable to expect that standards in terms of energy efficiency will continue to improve and that any new buildings will be designed to have a very low energy consumption. Also, refurbishment of existing buildings will reduce their energy consumption over time. It may therefore be worth considering at the outset whether to invest in larger pipes so that the flow temperatures of the network can be reduced in the future should the demand on the network reduce. This may be balanced by reductions in overall demand. Alternatively additional capacity freed up by improvements in energy efficiency could be used to serve additional consumers.

Impacts on pipe longevity

Increasing the temperature on a network designed for low temperature operation could have significant implications depending on the type of pipe installed. Plastic pipes are not designed to withstand high temperature and will be damaged should the temperature rise too high. It is noted that the design temperature of some of the existing network is 120°C and 16 bar pressure. This operational regime would not be suitable should plastic pipes be used in the network as the temperature and pressure will be too high.

Even if increasing the temperature does not lead to immediate failure of the plastic pipe work, it is worth noting that plastic pipes are less able to withstand the physical forces of expansion and contraction that are greater in a network with a high supply temperature.

5.6 Impacts on connected building systems

Lowest temperature source that can connect

The lowest temperature heat source that could be connected to a network depends on the flow temperature of the network. Connecting a heat source with a lower temperature to the flow temperature of the network will, of course, cool down the network flow. A source with a higher temperature than the network flow can be connected via a mixing station, where the return water will be used to re-circulate and reduce the overall flow temperature of the network.

The absolute lowest temperature the network can operate at will depend on the temperature requirements of the connected customers. An underfloor heating system can operate at approximately 40 °C, but existing buildings will usually have heat delivery systems that require a much higher temperature of operation (see Section 3.3.2).

Importance of low return temperatures

It is important to the efficient operation of a low temperature district heating system that low return temperatures are achieved from connected buildings. This is particularly critical to systems where CHP is used as a heat source. For existing buildings it is very difficult to impose an obligation to return at a required temperature, since there will be an existing building heat distribution system and modification to meet the criteria may require significant investment.

It is important that each building is considered separately for connection and that the existing system and potential to provide the required return temperatures is taken into account. On a low temperature system high return temperatures could make a significant impact and it is worth remembering that this could make the connection of some buildings unviable. Low return temperatures can also be encouraged by offering incentives to customers to reduce the return temperature from their building. This could include offering discounts on the heat price should the return meet the required temperature profile.

5.7 Conclusions

The following conclusions can be drawn from the previous section:

- A low temperature heat source can in theory be integrated into a high temperature network however the heat is usually upgraded to the same temperature at which the network is running using heat pumps.
- Direct connection of low temperature sources is not advisable due to the cooling it will lead to in that part of the network and the difficulty of controlling this in the context of the operational characteristics of the network. For larger networks with stable operating parameters integrating lower temperature sources directly is possible. Alternatively networks can be split into a number of areas at different temperatures, the interface between which typically has a heat exchanger and mixing station on the lower temperature side.
- The feasibility of connecting a low temperature source to the return leg of a district heating mains will depend on the nature of the primary plant. If this is CHP, a return temperature as low as possible is required thus connection to the return leg is undesirable. The same issue applies when connecting to low temperature sources.
- There are a number of issues associated with operating networks at different temperatures which have implications for connection of low temperature sources to traditional networks and for design of new networks. These relate primarily to:
 - pipe size: a larger pipe size is required at lower temperatures to accommodate the larger volume of water required to meet heating needs (due to the lower temperature differential between flow and return for lower temperature networks). For future flexibility in terms of temperature designing in spare capacity may be advisable
 - losses: lower network operating temperatures lead to lower losses (up to 38% for a 15 °C reduction).
 - pipe material: plastic pipes, which are generally cheaper and more flexible, can be used at lower temperatures. However, they are not designed to withstand high temperatures and will be damaged should the temperature rise significantly. They are also only available up to around 125mm diameter, limiting capacity. Typically they are used as twin pipes on service connections to buildings where most losses in a heat network occur.
- Networks with a low supply temperature can give rise to potential issues of Legionella growth within domestic hot water systems. This can be mitigated by either limiting the amount of

water held in the system at any one time or by heating the water to above 65°C. In Denmark new build domestic properties use the former approach. Another approach is to use chemical dosing. Engagement with UK public health authorities is required to understand whether the Danish approach would be acceptable in the UK. In any case it is only likely to apply to new build properties.

- Achieving low return temperatures is particularly important for system efficiency of a low temperature network. This will depend on the characteristics of the connected buildings. It may be the case that some buildings are unviable to connect if they cannot provide the low return temperatures required. Pumps in new buildings should be designed to turn down to almost zero flow.
- Peaks of heat demand should be avoided as far as possible to optimise the operation of district heating systems. This can reduce the need for top up boilers.

6 Emerging opportunities and pilot study

6.1 Overview

This section looks at potential emerging opportunities for secondary heat capture and low temperature heat networks in London. It takes a city wide view using the Phase 1 results to determine possible opportunities based on the geographical balance of supply and demand. It then considers one of these in more depth as a pilot study area, exploring the demand and supply balance and the impact of storage in more detail. A specific piece of modelling has also been undertaken to examine the opportunities for low temperature networks which make use of decentralised heat pumps and ambient network temperatures. This technology is appropriate in areas with a good balance of heating and cooling demands.

6.2 Emerging opportunities

Using the Phase 1 results a shortlisting exercise has been undertaken, highlighting the most promising areas for low temperature heat sources within London. Figure 6-1 shows the demand suited to low temperature heat networks for the Ambitious 2050 scenario. The shaded areas show MSOAs which have had this demand met by supply in that area. Of these shaded areas, a number of emerging opportunity areas has been highlighted. These provide a cross-section of opportunities and were selected on the basis of the following criteria:

- Availability of multiple secondary heat sources
- Availability of quantum of heat sources
- Location with high density heat demand area making district heat networks more viable
- Location close of existing or planned district heat networks
- Ability of available secondary heat sources to meet majority of heat demand within a given area
- Knowledge of stakeholders supportive of secondary heat sources and district heating.

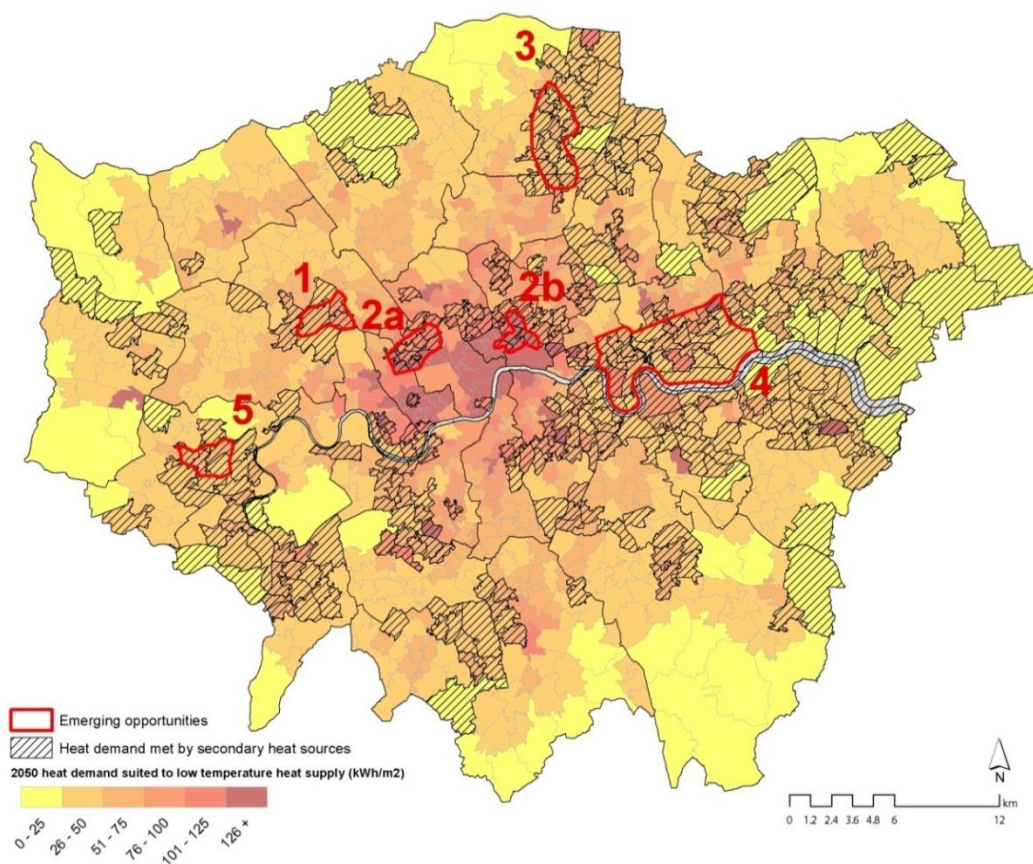

Figure 6-1 – Emerging opportunities for low temperature heat networks

6.2.1 Emerging opportunities shortlisting

Table 6-1 shows five key areas which should be investigated further for the application of low temperature heat networks. These areas relate to those highlighted red in Figure 6-1. Areas with high ground source and air-source availability have been excluded from this list because of their associated high costs of generation.

Table 6-1 – Shortlisting criteria for emerging opportunities for low temperature heat networks

Area selected	Opportunity	Reasons for shortlisting	Key stakeholders
1	Brent Park	Data centres and transformer stations supply	National Grid, UKPN, Options Technologies Ltd, Telecitey Group, Vital Group
2a, 2b	Paddington, Farringdon	Demand well suited to low temperature sources	Westminster City Council, Islington Council, private commercial stakeholders
3	Edmonton	Low carbon power station supply, minimal commercial risk	LondonWaste, E-ON
4	Barking and Royal Docks	Multiple heat sources, existing network forecast, extensive new build	Various
5	Hounslow	High supply (water treatment works, river abstraction) and reduced network costs.	Thames Water, Environment Agency

6.2.1.1 Emerging area – Brent Park

This area contains multiple large transformer stations and public data centres. These systems produce high quantities of waste heat throughout the year at a moderate grade. Data centres represent one of the lower carbon sources as heat can be recovered at temperatures around 40°C, reducing the heat pump compressor energy required to reach temperatures suitable for supply into a heat network.

The feasibility of such a system may be hampered by the commercial risks of these sources. A clear contractual structure is required to engage with distribution network operators. For data centres, the resilience of their systems cannot be compromised and considerable work is required to determine the feasibility of recovering heat from the condenser side of the data centre chillers. It may be more straightforward to recover heat from the chilled water return (evaporator) side of the chillers which is likely to operate at around 12-16°C.

Pros – minimal seasonal variation, high supply, low carbon intensity

Cons – high development risks, restricted demands and relatively low building density may lead to higher network costs.

6.2.1.2 Emerging area – Paddington and Farringdon

These areas present similar opportunities and so are assessed together. By virtue of the large amount of new build, commercial floor space and housing there is an opportunity for a low temperature network, reducing the heat pump compressor energy required to otherwise boost the low grade heat supply. Offices, retail and supermarkets provide a balance of heating and cooling both in demand and supply (HVAC heat rejection). As such there is also the opportunity to develop a district energy sharing scheme, as discussed in Section 6.4.6.

Heat supply would be primarily from building cooling system heat rejection with an option to connect to local transformer stations to offset the diurnal and seasonal variation in building cooling system heat rejection. Though these supply sources are more carbon intensive than in other emerging areas, the building fabric improvements to provide a lower temperature network would be less. This gives a more commercially viable solution assuming that heat networks are established using conventional district heating by 2030.

Unlike Brent Park and Edmonton, these networks would be reliant on a number of small capacity systems as opposed to one or two central units. Though this poses some commercial risk, the capital costs of the heat recovery infrastructure can be diluted amongst potential stakeholders.

An underlying trunk sewer also presents the opportunity for the inclusion for heat recovery. This is an important factor as during winter months the heat rejection from building cooling systems is minimal and so the more consistent temperature of sewer heat mining will provide diversity to the system supplying the winter base load, topped up by more conventional sources.

Pros – low temperature suited demand, diluted capital costs

Cons – high seasonal variation, high carbon intensity, limited supply, complex stakeholder issues.

6.2.1.3 Emerging area – Edmonton

This area has been selected because of the large quantity of waste heat available from Edmonton Incineration and Enfield Power Station. Though demand for low temperature heat is currently

limited, new development around Tottenham and the A1010 corridor may suit a low temperature network. A high temperature district heat network from the waste incinerator is currently being considered by Enfield and Haringey Council - by 2030 the conversion or extension of this to include low temperature heat sources presents a viable opportunity.

Pros – minimal seasonal variation, steady base load, existing network, long term source of heat from waste to energy plant

Cons – limited demand suited to low temperature heat

6.2.1.4 Emerging area – Barking and the Royal Docks

Barking and the Royal Docks presents the largest mix of supply sources in one area. Central to this are Barking Power Station, the Tate & Lyle sugar refinery and Becton Sewage Treatment Works. Unlike other areas of London, these large producers of waste heat are coupled with a high demand in the Royal Docks and Canary Wharf, where continued new development can be suited to low temperature networks.

The supply and demand areas are currently somewhat decoupled, however looking forward to 2030 it is envisaged that the Thames Gateway Heat Network will be in place and will be utilised to provide the main distribution infrastructure.

Though power station heat rejection will be fairly consistent, storage should be considered for commercial sources more central to the royal docks, as seasonal and diurnal variation is of these is likely to constrain supply.

Pros – large quantum of supply and demand, future network infrastructure

Cons – large study area, high development costs, buildings may require retrofit to enable supply via low temperature networks.

6.2.1.5 Emerging area – Hounslow

This area has been selected for its potential as a small pilot study. The low density of the area reduces the cost of providing a new purpose built heat network compared to central London. The supply would come from Mogden sewage treatment works. This site treats 595,000 m³ of effluent per day and represents one of the largest sources of low grade heat in the area.

Demand in the area is not well suited to a low temperature network and so there would be a need to boost this to more conventional temperatures or retrofit buildings to improve their thermal efficiency and the buildings' ability to adequately cool the return water. The viability of this would be dependent on the future difference in gas and electricity prices. This may suit an ambient temperature loop with local in building heat pumps due to the reduced network costs and low losses.

Pros – large quantum of low grade heat, fairly consistent temperature

Cons – no existing network, high heat pump costs, relatively low heat demand density.

6.3 Pilot study area

A pilot study area approach was undertaken to test the opportunities for using secondary heat sources with data based on a real world example.

From the emerging opportunities highlighted in the previous section Barking and the Royal Docks has been selected as the most suitable to progress as a pilot study area. This area contains a diverse mix of secondary heat sources as well as a mixed demand including areas suited to low temperature supply. The Thames Gateway project has already demonstrated that this area is well suited to heat networks, with a high possibility of a network being in place by 2030.

6.3.1 Pilot study methodology

Following selection of the pilot study area the following activities were undertaken:

- Identify, locate and quantify low temperature sources
- Identify and quantify and spatially map demand
- Model the costs of heat and available supplies, prioritising by lowest cost
- Map the infrastructure and main supply and demand sources
- Calculate the energy balance including load duration curves
- Model the impact of storage

Alongside this work a separate piece of modelling was undertaken to explore the potential for a very low temperature system that uses and balances heating and cooling loads within an area, referred to as a District Energy Sharing System (DESS)³⁴ See Section 6.4.6.

6.3.2 Sources

Supply sources have been based on the analysis carried out in Phase 1 of this study. Where available, further data has been collected from previous heat mapping exercises done in the area. Key to this is the Royal Docks and Canning Town Energy Infrastructure Report³⁵. Additional information on Wood Wharf heat recovery (associated with the rejection of commercial building heat into Wood Wharf) is detailed in the Tower Hamlets Wood Wharf Energy Strategy.³⁶ The supply sources are considered for a 2050 scenario to allow for infrastructure that has not yet been built but is feasible or has been granted planning permission. Levelised and counterfactual costs have been modelled for the BAU 2010 scenario.

Sources not included from the Phase 1 study include 'Part B' industrial processes (dropped because of minimal supply), sewer heat mining (dropped in favour of sewage treatment plant heat recovery) and London Underground heat recovery (no ventilation shafts in study area).

The exhaust system for Crossrail at Canary Wharf station has been investigated as a potential heat source, however this system differs from that studied for London Underground in using under platform exhaust (UPE) ventilation. It is unclear how this heat would be recovered and given the

³⁴ This work was undertaken by DEC Engineering in Canada. Case studies of DESS' can be found in the Phase 1 report.

³⁵ Ramboll & WSP, 2012. Royal Docks Infrastructure Study

³⁶ Atkins 2008. Wood Wharf Development Dock Water Study

low availability of heat predicted for the London Underground, this has not been pursued further at this time.

As environmental sources are less restricted than other supply sources, a practical limitation on the size of heat pump for river and wastewater abstraction has been added. This has been set to limit the maximum delivered heat for these sources to a 20MW capacity. A cap on air source heat pumps has also been added, with modelling restricted to a typical case from Phase 1 modelling of 12MW thermal capacity. A summary of available heat sources is given in Table 6-2 below.

The locations of major supply nodes within the pilot study area are shown in .

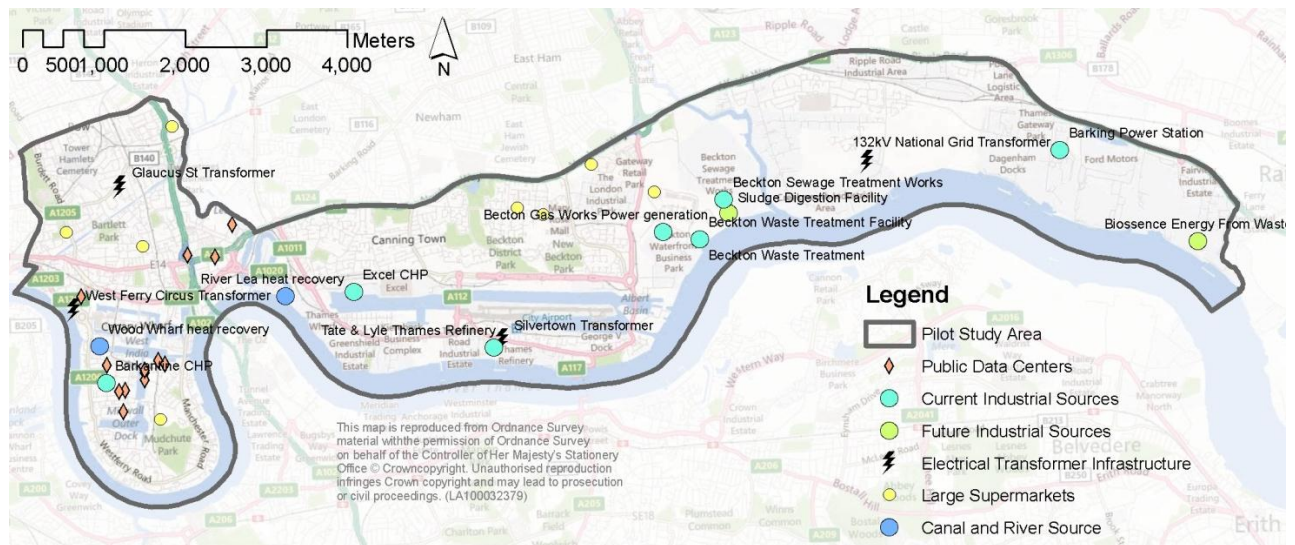

Figure 6-2 – Pilot area low temperature heat sources

Table 6-2 – Pilot study supply sources

Waste Heat Category	Site	Source temperature (°C)	Heat Producing Unit	Secondary heat capacity (MW)	Delivered heat at 70°(MWh/year)
Industrial Process Heat	Tate & Lyle	35	Crystallisation pan heat recovery	10.00	60,910
	Tate & Lyle	70	Flash steam heat recovery	2.70	13,482
Power Generation	Excel CHP	45	Gas fired CHP Intercooler heat recovery	0.24	1,363
	Biossence Energy from Waste	35	Condenser heat recovery	50.00	482,553
	Thames Water Desalination Plant	70	Engine jacket heat recovery	2.90	21,593
	Thames Water Enhanced Sludge Digestion Facility	70	CHP engine jacket heat recovery	2.40	17,870
	Becton waste treatment facility	35	Condenser heat recovery	11.00	105,790
	Beckton Gas works pressure reduction station	35	Fan cooler heat rejection Waste heat downstream of ORC heat exchanger	3.00 1.00	40,606
	Barkantine CHP	45	Intercooler heat recovery	0.24	1,359
	Barking power station	35	Condenser heat recovery	600	3,077,541
Infrastructure Sources	National Grid electrical infrastructure	55	Transformer Heat Recovery	6.8	34,271
	UKPN substations	55	Transformer Heat Recovery	1.63	6,622
Environmental heat sources	Becton STW	14-22	Sewage heat pump	20	144,892
	Lea River Heat Rejection	5-20	River water heat pump	20	184,467
	Wood Wharf (current)	17	River water heat pump	20	110,207
	Wood Wharf (future)	17	River water heat pump	20	110,207
	Distributed	2-16	Air source heat pumps	12	63,565
	Distributed	13	Ground Source (closed loop)	30	407,299
Commercial non HVAC heat rejection	Distributed	32	Large supermarkets	0.75	8,327
	Distributed	40	Data centres	28	212,290
Commercial HVAC	Distributed	28	Office and retail heat	43	166,549
Totals				883	5,264,327

6.3.3 Demand

The heat demand in the pilot area has been taken from previous studies carried out by Ramboll in the areas surrounding the Royal Docks and Canary Wharf.^{37,38} This data includes all building stock which has been deemed suitable for a conventional heat network connection.

Heat demand data for the Royal docks has been sourced from the report ‘Royal Docks and Canning Town – Energy Infrastructure Report’.³⁷ This includes both current and future heat loads. Data for the study area in Tower Hamlets to the west has been collated from the London Heat Map.³⁸ Demand to the east of the Royal docks has been excluded in favour of these areas; this is due in part to the low quality of data available but also the lower heat density in these areas.

For modelling purposes it has been assumed that heat will be supplied at 70°C with a return temperature of below 50°C (ideally closer to 35 °C). To reflect this in the demand profiles 3% of the demand is assumed to require higher temperatures and has therefore been subtracted from the gross demand. This is based on the modelling results from Section 3.3.

This peak high temperature demand could be supplied through centralised peak load heating systems. This would likely be cost effective and would not require building owners to own and service peak load equipment which runs for only a few hundred hours per year.

Typical residential and non-residential annual demand profiles have been assigned to the heat demands, generated by considering occupancy profiles and apportioning part of the load to external conditions (degree days).³⁹ This resulting annual profile is shown in Figure 6-3

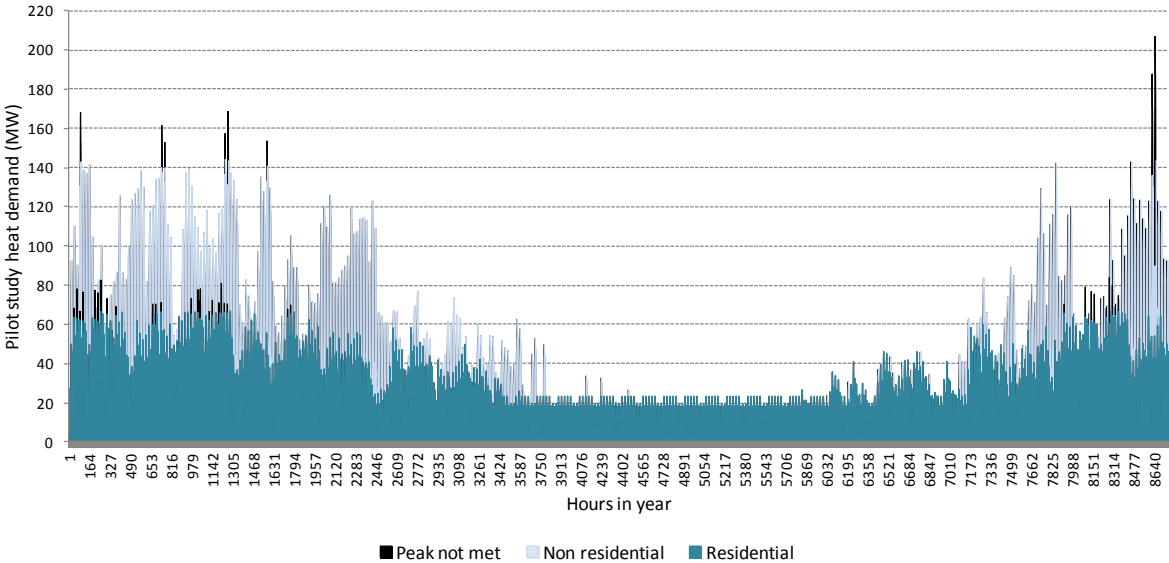

Figure 6-3 – Annual heat demand profile showing loads not met by a 70 °C heat supply

³⁷ Ramboll & WSP, 2012. Royal Docks Infrastructure Study
³⁸ Ramboll 2011. The London Borough of Tower Hamlets. London Heat Map Study
³⁹ Met Office. Heathrow Weather Station hourly weather data 2012.

Table 6-3 – Heat demand suited to 70°C heat network

Study area	Residential heat demand (MWh/year)	Non residential heat demand (MWh/year)
Tower Hamlets	133,880	195,690
Royal Docks	51,720	51,120

These demands are a high level estimate as there is limited data on the ability of buildings in the area to utilise secondary heat at low temperatures. Better data on building thermal efficiency, heating systems and heat emitter size is required to facilitate this and collection of this data would be essential to further progress this as a project. As such, demand modelling herein is subject to significant uncertainty.

6.3.4 Energy Balance and levelised cost of heat

An energy balance assessment has been carried out to assess the priority of supply in the pilot area. The cost model used is 2010 BAU, although it is assumed that all networks and supply sources in the area have been developed and so there are therefore no associated network cost. The exception to this is the Biossence energy from waste plant to the east of Barking Power Station. As there is a significant distance from this site to any proposed network an additional network cost has been included in this instance.

Levelised costs from the London wide study have been used to prioritise sources. Costs associated with technologies not covered in Section 2.3 are detailed in Table 6-4 below. These include where possible previous costing work done for site specific sources⁴⁰:

- CHP intercooler heat recovery – Excel CHP
- CHP engine jacket heat recovery - Thames Water Enhanced Sludge Digestion Facility
- Flash steam heat recovery – Tate & Lyle sugar refinery

System and levelised costs for canal heat are taken as the same as river source heat pumps and the Biossence network link is inclusive of costs for a 2.8km heat connection back to the main heat network. For Barking Power Station the capital cost and capacity are the same as discussed in Section 2.3 for a typical power station connection, however the load factor in this instance is 10% to reflect current market conditions for gas plant operators (due to low coal prices). This increases affects the levelised cost when compared to a more typical power station as fewer units of heat have to absorb the same capital costs.

⁴⁰ Ramboll & WSP, 2012. Royal Docks Infrastructure Study

Table 6-4 – Additional heat supply sources for the pilot study area

Technology	Typical heat capture capacity (MWth)	Indicative system cost (£)	Levelised cost of delivered heat at 70°C (BAU 2010 scenario)	
			Infrastructure cost (p/kWh)	Heat pump energy cost (p/kWh)
Flash steam heat recovery	2.27	391,000	0.35	0.00
CHP engine jacket recovery	2.4	370,000	0.32	0.00
CHP intercooler heat recovery	5	1,787,000	0.72	1.34
Canal	20	7,255,600	0.50	1.78
Barking Power station	20	7,144,800	4.02	1.28
Biossance network link	-	2,158,400	0.03	0.00

By prioritising heat supply based on levelised costs, an hour by hour optimisation model has been developed using the software package EnergyPro. The results of this analysis are discussed in the following section, including the potential impact of heat storage.

6.4 Results and discussion

6.4.1 Levelised cost

As in Section 2.3, the results of levelised cost modelling have been used to plot a marginal cost curve for the pilot area. Figure 6-4 is reproduced at a larger scale in Appendix C. The demand in the study area is shown as a dotted line, however this does not include considerations of heat source availability. To meet this demand throughout the year, a larger number of sources are required than is at first apparent. This is discussed in Section 6.4.2.

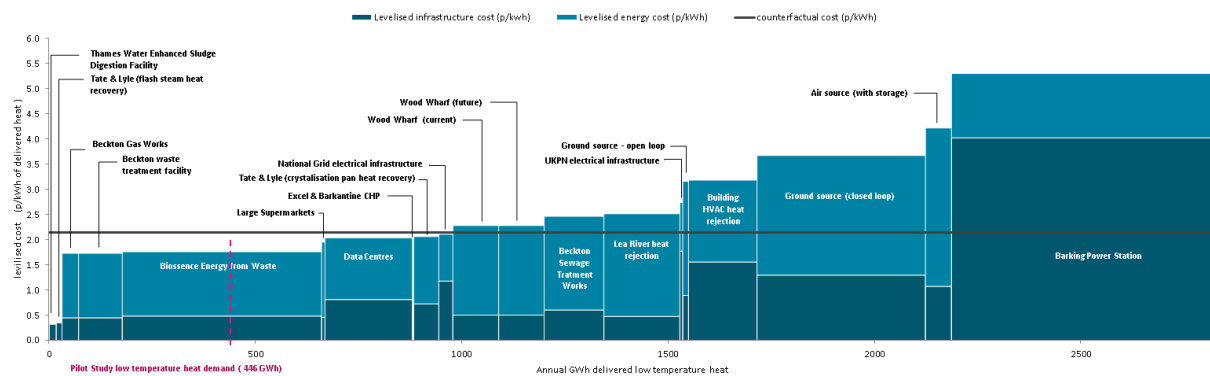

Figure 6-4 – Pilot study heat supply cost curve (BAU 2010)

A key observation from this graph is the high number of supply sources with a levelised cost below the counterfactual cost of decentralised large gas boilers. These technologies are dominated by the power and industrial infrastructure sources because of their comparatively high load factors and available heat temperatures. The exception to this is Barking Power Station. Though this source has a large quantity of waste heat, the low load factor assumed causes a particularly high levelised infrastructure cost when compared to a more typical power station case as modelled previously.

In Figure 6-5 building HVAC heat rejection is considered less cost effective than the counterfactual case. This source, more than most, is dependent on the specific site. The levelised cost is based on typical office buildings in the study area and includes a majority of buildings that do not require year round cooling and hence have a seasonally associated heat rejection. As the scale of office buildings increases in areas such as Canary Wharf, the requirement for air conditioning is likely to increase. Increasing the load factor of this source to 80% (from 34% in the model) would reduce the total levelised cost to 2.3p/kWh. Though an improvement, the total levelised cost remains above that of the counterfactual case as this change does not affect the levelised infrastructure cost. This portion of the cost is high because of the size of heat pump required at a building scale which has a high cost per unit output. The effect of scale on levelised cost is discussed in Section 2.3.2.3.

As previously, the relationship between levelised cost and carbon intensity is shown in Figure 6-5. The diameter of the circles represents the quantity of delivered heat annually.

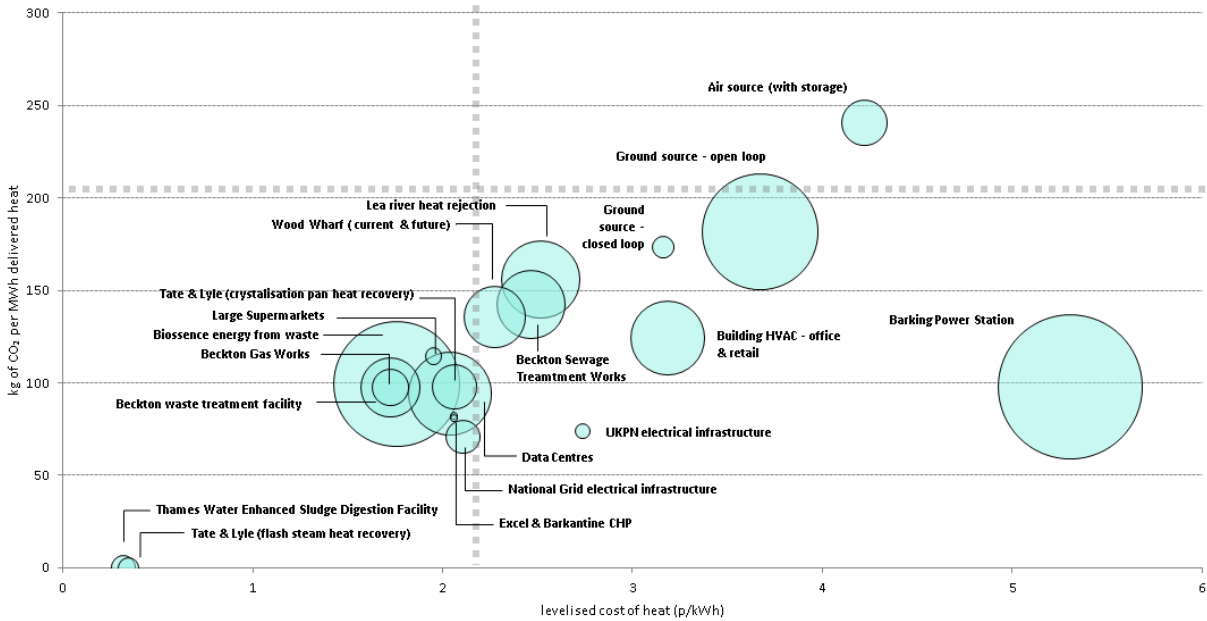

Figure 6-5 – Carbon intensity v levelised cost of secondary heat sources within the Pilot Study area (BAU 2010)

Figure 6-5 shows that canal heat rejection (Wood Wharf) is the most competitive of the ‘environmental’ sources. This is due to the temperature of the canal being largely governed by the building heat rejection into it and does not fluctuate seasonally to the extent as would be expected of a river. A future as well as current source has been included for Wood Wharf to allow for the considerable planned development in this area which is also expected to discharge waste heat into the canal.

As with the London wide analysis, all sources except for air source heat pumps are less carbon intensive than the counterfactual case. Excluding industrial sources available at 70°C, all sources with a lower cost than the counterfactual case are of a similar carbon intensity. Heat delivered from Barking Power Station, though at a high cost, is of a relatively low carbon intensity and available at a high capacity. In a scenario where the run hours of this power station were improved or financial incentives were accounted for, this would become an attractive source. As such it has the potential to be a more attractive source than ground, river or air source, which have little scope for movement in the priority order.

6.4.2 Energy balance modelling

The energy balance modelling accounts for the seasonal and diurnal variation inherent in the majority of heat sources. Heat sources with a levelised cost higher than that of Wood Wharf heat recovery have been excluded as it is assumed the more conventional heat supply sources will be more attractive beyond this, partly on a cost basis but also in limiting the number of supply sources into the network. Having a proportion of the heat load supplied by conventional gas boilers is also necessary for resilience and to cover unexpended peaks in demand. Figure 6-7 shows the results of this modelling, giving the % of total demand which is met by each source.

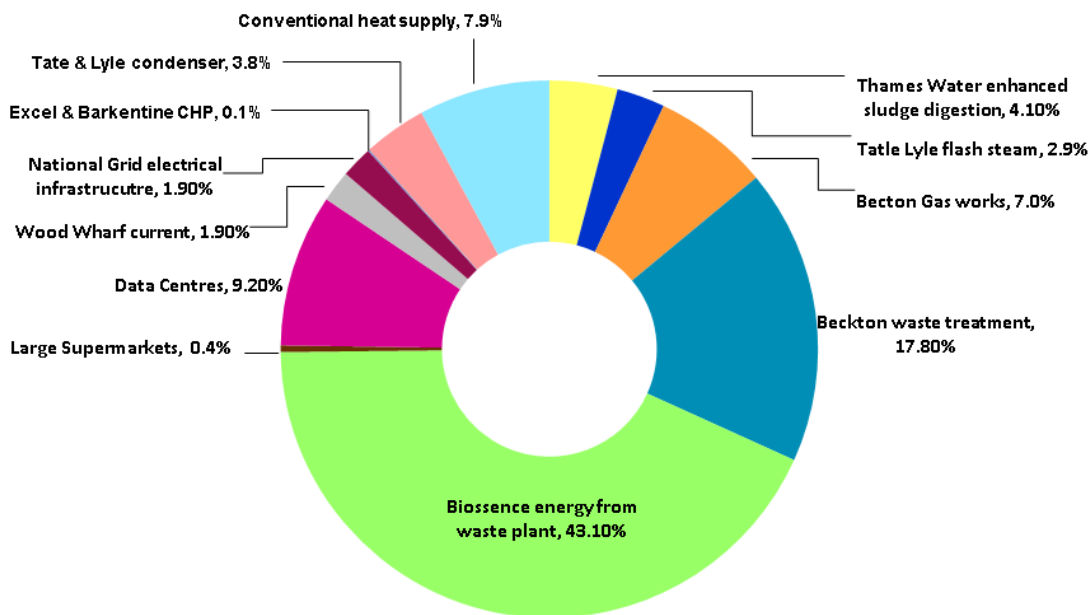

Figure 6-6 – Pilot study area energy balance

The percentages above account for the varying run hours of supply sources across the year. This is demonstrated below for an indicative winter week. The baseload is met by the supply sources with the lowest levelised costs, followed by sources that have a lower cost than the counterfactual case but have lower run hours because of significant seasonal/ diurnal variation.

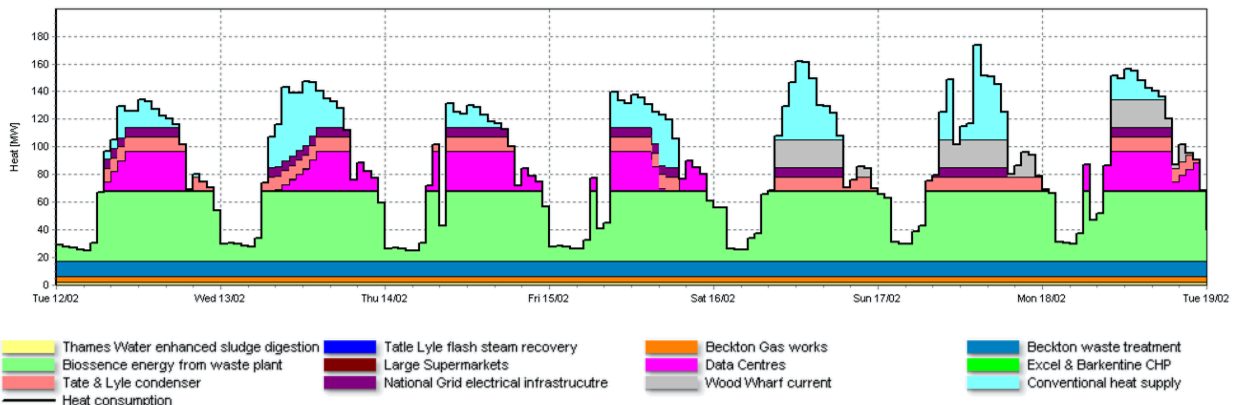

Figure 6-7 – Heat production graphic for typical winter week

The effect across the year can be shown as a load duration curve. This shows that the predominant heat supply source is heat recovery from Biossence energy from waste plant due to the high run hours and large capacity of the source. Tate & Lyle flash steam heat recovery and data centres, while low cost, can only be relied upon for parts of the year. During these down times the gap in supply is met either by other secondary heat sources or by a conventional heat supply.

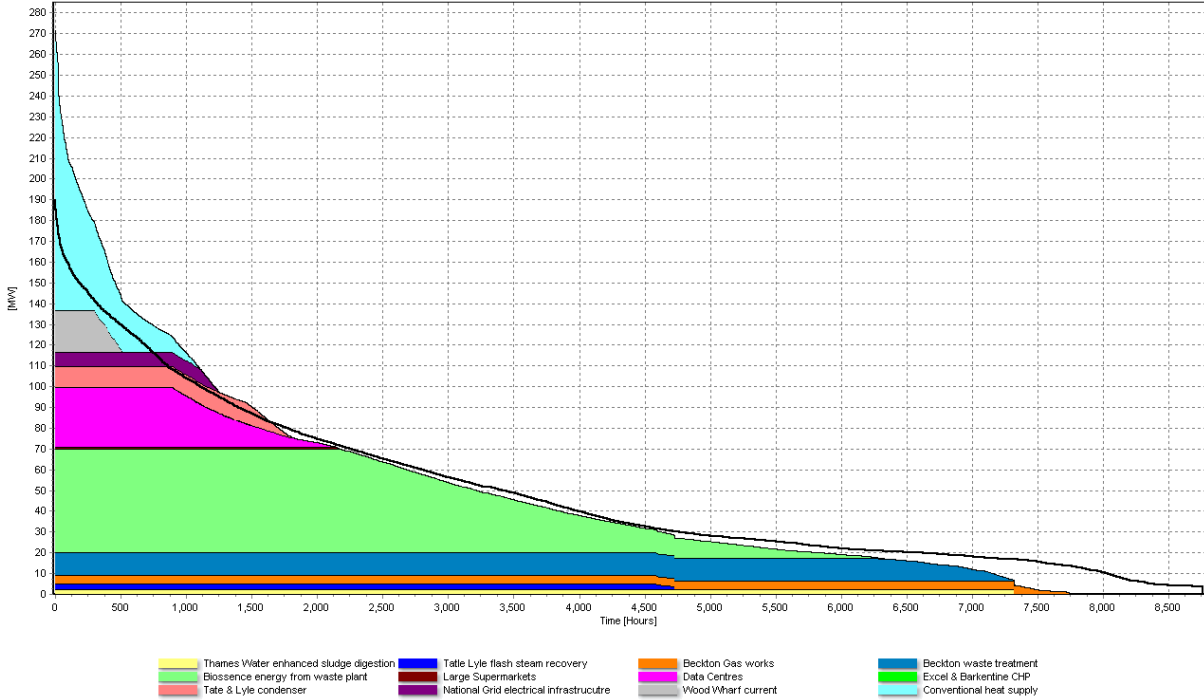

Figure 6-8 – Duration curve for pilot study heat supply

The resulting load duration curve is shown in Figure 6-8. This demonstrates that the demand for heat can be met by a network including approximately half of the available secondary sources. The annual base load is met by sources with small heat pump compressor power requirements. This includes heat recovery from engine jackets and from data centre heat rejection. The energy from the sources with lower utilisation could be replaced with conventional heat sources such as gas fired CHP or energy from waste CHP. Alternatively supply at higher temperatures would be provided by decentralised gas boilers or heat pumps running independently from the low temperature district network though neither of these would provide carbon savings.

6.4.3 Single vs. multiple supply sources

The nature of most secondary heat sources means that they are all constrained in some way by diurnal or seasonal constraints. This can be down to environmental constraints or constraints invoked by a third party, e.g. load factor constraints applied to power stations or electrical transformers. To guarantee a continuous supply into the network it would be necessary to connect a number of different sources to balance out this variation in supply.

The converse argument is that this approach increases the commercial risk to the heat network developer in securing multiple contracts with a number of different suppliers. By utilising a small number of large scale sources the baseload demand could be met, with backup and peaking plant provided by more conventional means. Though the carbon savings from this approach would be

less than a 100% secondary heat network, the risk to the developer would be far less. In practice most systems would start in this way, adding a more diverse and lower carbon range of sources as demand grew and finances allowed.

Sources such as water treatment works, though currently of a higher cost than the counterfactual case, may become attractive in such a scenario. Furthermore if financial incentives were available, this cost difference could be closed. Recovering heat from London Underground by contrast has both a limited capacity and a high cost and so is less attractive. This conclusion does not affect the viability of such systems on a local scale, particularly in conjunction with supplying cooling services to Underground stations.

6.4.4 Thermal storage

The energy balance can be improved by including hot water storage tanks at key supply sites to store heat produced at times when there is no corresponding demand.

Thermal stores can be used as ‘dumps’ for heat produced at low cost during off-peak periods or when excess electricity from wind generation is available at low or negative cost. Where sources do not require heat pumps to reach required temperatures, this energy would be available at no additional energy cost and this can be used to effectively maximise the load factor of the lowest cost sources.

An indicative schematic of this effect is given in Figure 6-9, where the peak load is presumed to be met by conventional heat sources.

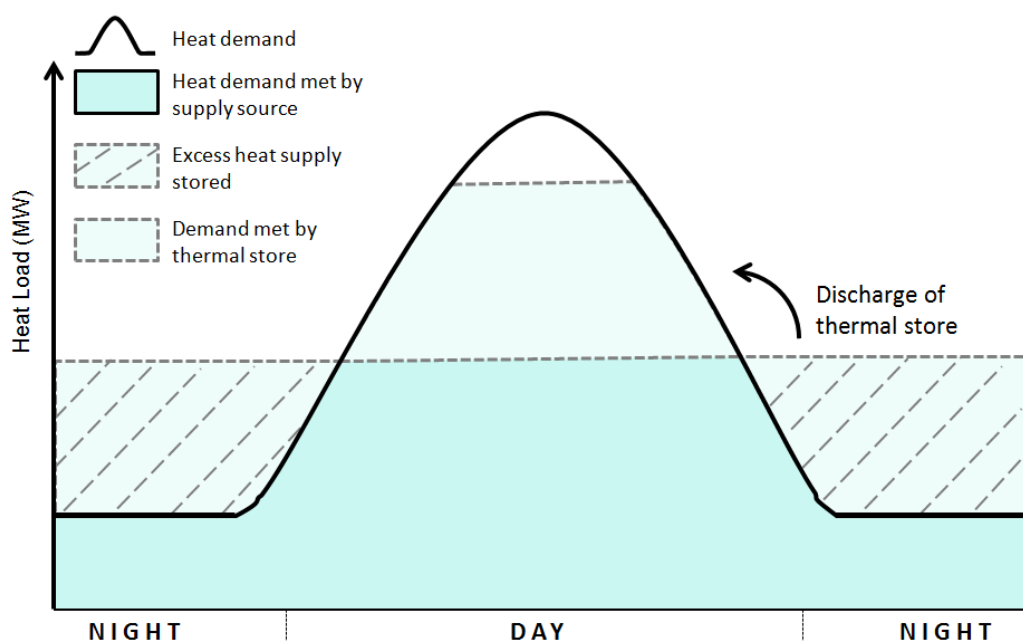

Figure 6-9 – Principles of thermal storage

The impact of storage has been assessed by focussing on the top 5 supply sources. Excluding storage these produce 368,497 MWh which can be utilised by the pilot study demand. Adding storage of 100m³ and 500m³ can increase this supply by an additional 468 MWh and 2,133 MWh respectively with a minimum associated increase in capital costs. Although in some case this additional supply will still require electricity input for heat pumps, it reduces the demand on higher cost sources of heat supply which are no longer required.

The above approach only considers diurnal storage and does not address the issue of sources which vary seasonally based on ambient conditions. In such cases it is possible to store heat for several months using aquifer thermal energy storage (ATES). The costs and energy benefits of such a technology must be considered in full. Storing heat at the temperatures envisaged for low temperature heat networks (50-70°C) is likely to result in efficiencies of around 70%. The storage systems may also be expensive compared to adding additional secondary heat sources where there is greater supply than demand. This approach would likely be restricted to sources with both a large capacity of low carbon waste heat available at suitable temperatures (e.g. higher source temperatures not requiring heat networks). ATES systems can be used at very low temperatures directly in buildings and in this guise can be used with ambient networks discussed in Section 6.4.6.

6.4.5 Network

The pilot study would utilise network infrastructure that is planned to be installed between now and 2030. The split between existing and potential network is given in Figure 6-10 below. These networks are those proposed as part of the London Decentralised Energy Delivery Unit’s work as part of the Thames Gateway network. Where additional pipe work would be required this has been added as a dashed line.

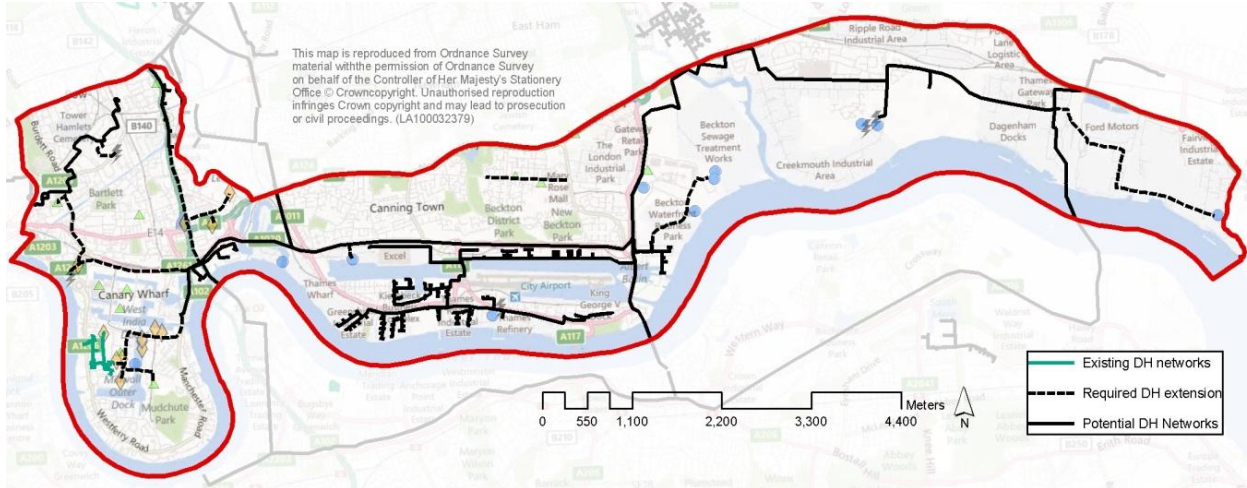

Figure 6-10 – Pilot study network map

6.4.6 District energy sharing

Alongside the above analysis, a separate exercise was undertaken⁴¹ to explore the potential for a very low temperature or ambient (LT Type D) heat network based on the principles of a district energy sharing system (DESS).

An ambient temperature system has the advantage of being able to make direct usage of low grade heat sources, with heat (or cooling) being generated at the point of connection to a building or to an intermediate energy transfer station.

⁴¹ This work was undertaken by DEC Engineering, Canada. Their full report is included in Appendix E.

The system is based on a low temperature un-insulated distribution system that draws energy from diversified sources. Two pipes, one warm, one cool, connect various loads and sources through distributed Energy Transfer Stations (ETS). An ETS can provide heating to connected buildings by drawing heat from the DESS warm line using a heat pump. The same heat pump can be used to cool the buildings in this case rejecting heat back into the DESS. Buildings in heating mode pull their heat from a warm pipe (10°C to 20°C) and dump their cool water in a cool pipe (5°C to 15°C). Buildings in cooling reverse this process and pull cool water from the cool pipe and reject heat to the warm pipe. This exchange and reuse of energy is called energy sharing, or heat recovery from building cooling processes. Heat pumps also enable each building to look after its own internal heating and cooling needs, only making demands of the DESS when it has a shortfall in heating or cooling. Figure 6-11 provides a schematic illustration of how such a system is structured. A full description is provided in Appendix E with a connection schematic in Appendix F.

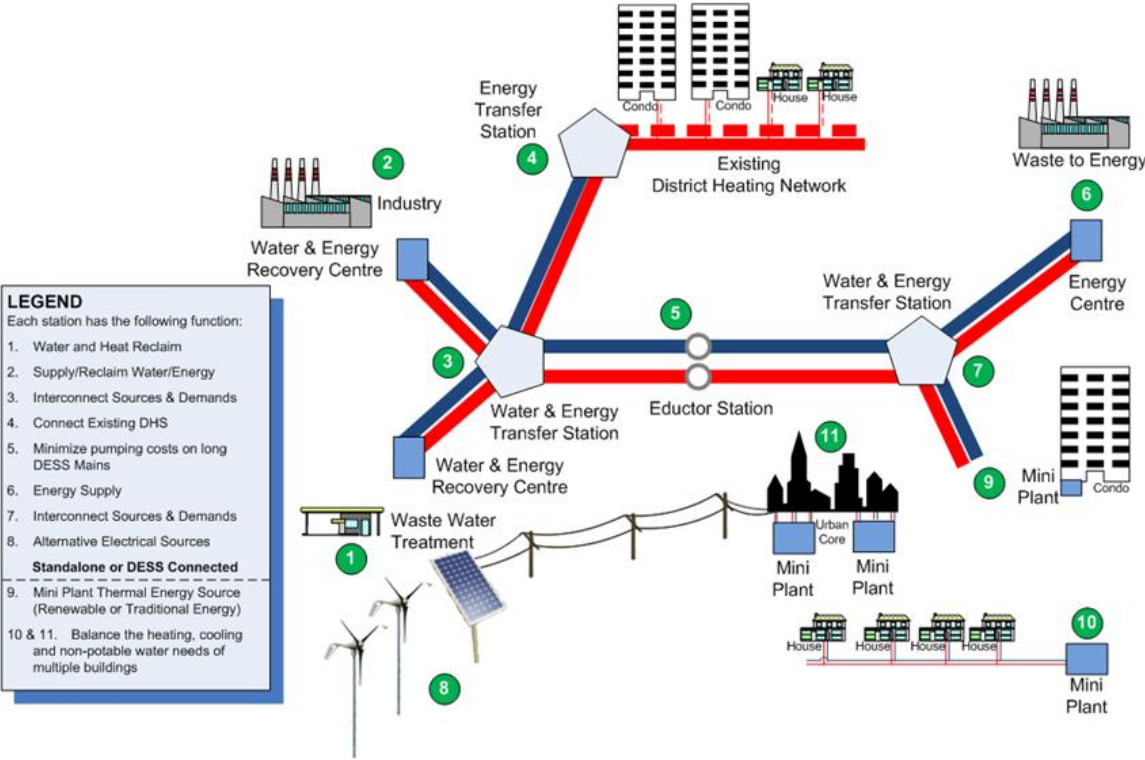

Figure 6-11 – Illustration of a District Energy Sharing System (DESS) showing interconnection between sources, loads and transfer stations (source: DEC Engineering, Canada)

Due to the large area involved, the DESS has been designed with modular build out in mind thus allowing incremental additions to the network as subsections are completed in phases. A DESS can be installed as a series of independent loops that eventually interconnect to transfer surplus heating from one loop to another. This approach reduces distribution pipe size, improves network reliability, and allows for extended build out timelines without negatively affecting performance. For the purposes of the study, two separate sub-sections were selected - Canary Wharf to the west and the Barking and Royal Docks area in the centre/east (Figure 6-12).

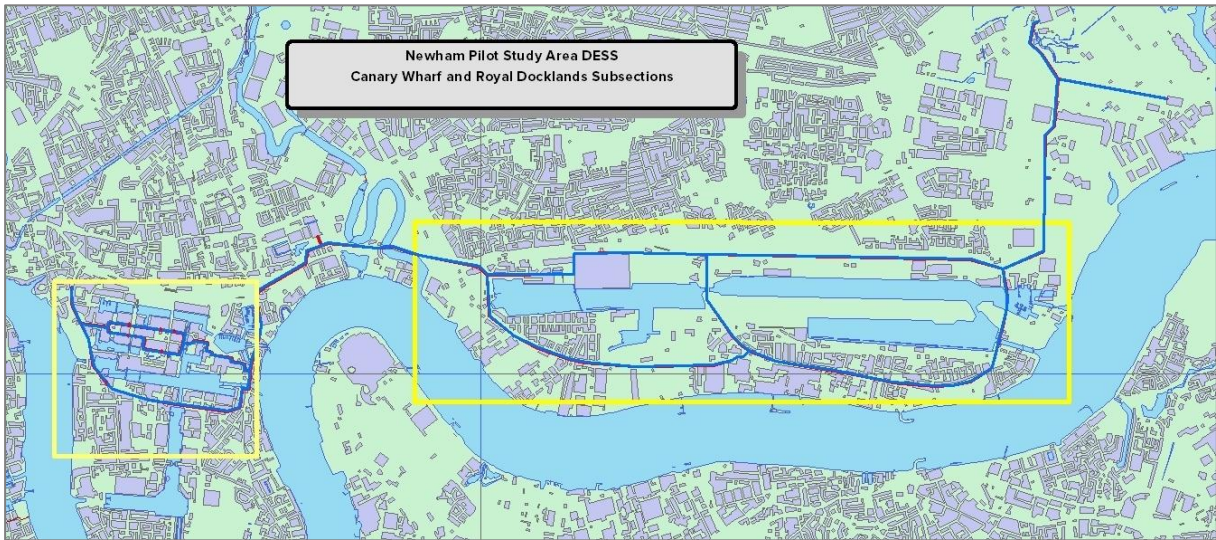

Figure 6-12 – Map showing potential location of two DESS sub-sections within the pilot study area, Canary Wharf towards the west and Royal Docks in the centre/east.

Based on the heat source and building profile for the areas, the Canary Wharf sub-section area was estimated to have a peak heating demand of 742 MW and peak heat rejection of 956 MW. These peak heating and cooling loads are assumed to be provided by boilers and chillers installed in each building. Given this existing equipment, the DESS capacity can be sized for only a fraction of peak capacity. Any demand in excess of the DESS capacity can be made up by the existing boiler and chiller systems. By sizing the DESS to meet 10% of peak heating, the ambient system can provide 49% of heat demand in the area. The majority (>85%) of the heat source in the area is assumed to be from commercial building cooling (HVAC) systems.

In the Royal Docks area peak heating and cooling loads of 89MW and 107MW have been estimated. A DESS sized to meet 23% of peak heating can provide 71% of heat demand in the area. The heat sources in this sub area are more varied than in the Canary Wharf area and include around 42% from industrial sources (excluding Tate & Lyle refinery for which the supply is so significant it is recommended that a separate analysis is undertaken as to how best to utilise it).

Table 6-5 – Summary of DESS capacity and supply in each sub-section

Area	Peak heat demand (MW)	Peak heat rejection (MW)	DESS capacity (MW)	% of heat demand met
Canary Wharf	742	956	74	49%
Royal Docks	89	107	20	71%

Network plans in relation to the above is provided in Appendix G.

In terms of carbon savings, it is estimated that by recovering heating and cooling energy within the two identified study areas overall annual fuel inputs can be reduced by 27 – 43% and carbon emissions reduced by 45 – 63% with 2050 electricity generation targets. Greater savings can be achieved by replacing the building heating boilers with local heat pumps, and in this case less electricity input would be required versus using all electric local air-source heat pumps and chillers.

6.5 Conclusions

Based on the Phase 1 analysis, there are a number of areas that could be suitable for the development of low temperature heat networks.

To take these forward, more detailed analysis is required as illustrated by the analysis undertaken for the Royal Docks area. Conclusions specific to the pilot study area include:

- The secondary heat supply in the pilot study area is extensive and can easily match the demand in the area
- There is limited data on the ability of buildings in the area to utilise secondary heat at low temperatures. As such modelling is subject to considerable uncertainty.
- The carbon intensity of the heat supply sources is lower than that of the counterfactual (gas boilers) under the BAU 2010 scenario.
- The quality of heat from secondary heat sources varies diurnally and seasonally because of environmental and operational factors. As such, the inclusion of diurnal and seasonal storage in any such network will help improve system efficiencies.
- Conventional gas boilers can be used to meet peak loads at high temperatures as well as reducing the number of supply sources required, reducing capital cost and operational and commercial complexity.
- There is scope for developing ambient energy sharing systems on a modular basis for the Canary Wharf and Royal Docks areas. These systems could generate considerable carbon savings and would make use of the waste heat available from the high cooling loads in the area. Further work would be required to fully explore the cost benefits of this type of system compared with an equivalent low temperature system that does not allow for two-way energy sharing between heating and cooling systems.

7 Employment and Investment Opportunities

Implementing secondary heat systems across the capital will lead to the creation of jobs, both in terms of construction jobs (manufacture of equipment, infrastructure) and operational jobs (operations and maintenance). A high level study has been carried out to assess the indicative economic impact of this effect. Assumptions have been made based on typical employment rates and the capital costs given in Appendix B. These rates have been calculated for a typical installation for each and then extrapolated in line with the maximum capacity detailed in the Phase 1 report.

Full deployment of the secondary heat systems discussed has the potential to create up to 51,000 jobs (based on BAU 2010 scenario). This equated to approximately £3.9bn however it is noted that 97% of these jobs are construction jobs of typically 3 to 8 months, depending on the scale of the project.

A breakdown of the total value of these employment opportunities is given below. Sources that have a high investment potential include air source (bespoke large heat pumps with high associated manufacture cost) and building HVAC heat recovery (small systems but a high volume across London if fully deployed).

Technologies that have smaller costs per installation include supermarket heat rejection and heat recovery from UKPN electrical infrastructure. These systems are assumed to use conventional heat pumps currently available and be controlled remotely reducing operational costs.

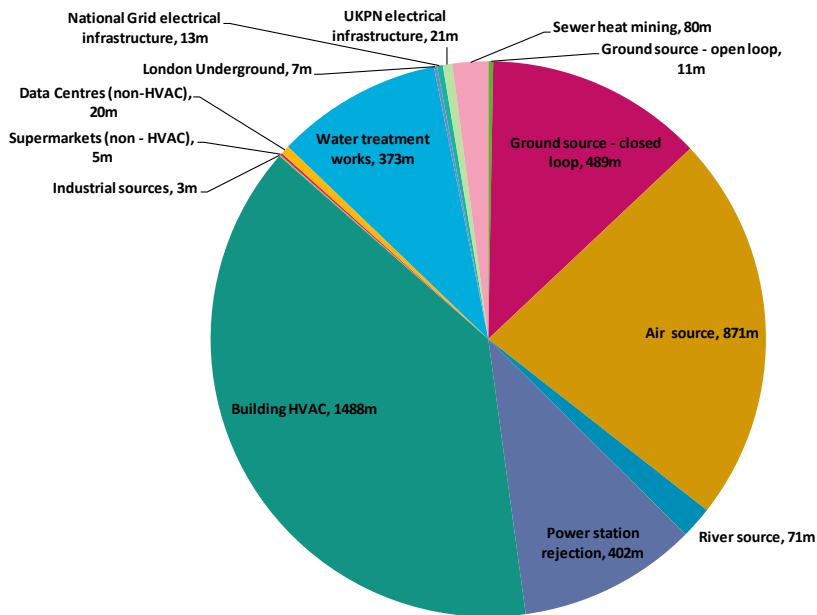

Figure 7-1 – Investment potential by supply source

8 Further work

This section summarises opportunities for further work arising from the conclusions of this report. Recommendations for policymakers will be included in the final report.

8.1 Heat supply

It is anticipated that most secondary heat sources would need heat networks to be in place in order to be economically viable. Using an alternative counterfactual such as individual heat pumps or condensing combi-boilers would require network costs to be modelled. Conversely this would provide a higher counterfactual price against which to compare heat from secondary sources. This may allow secondary heat projects to be viable without an existing network. This is highly dependent on future energy prices, and on the counterfactual used.

Detailed economic modelling should include a whole life cost comparison with a conventional district heating system. Although not modelled in this study to avoid bias towards a particular technology, funding schemes such as the Renewable Heat Incentive will affect the viability of some secondary heat sources considerably.

8.2 Connections

The modelling of building performance in relation to lower temperature heat supply is necessarily simplified in this study due to the breadth of the study's scope. A more detailed understanding using actual heating system design data would be highly informative. In particular it would allow greater granularity in understanding the impacts of improving the thermal efficiency of different building types and construction. In this study only four building types were modelled which do not accurately reflect the huge range of buildings in London.

Low return temperatures are key to enable use of low temperature secondary heat. Detailed best practice guidance should be developed and disseminated to building designers and heat network system developers with regard to ensuring this. A more detailed review of network sizing for low temperature systems in comparison to requirements for a conventional district heating system is also an area for further work.

The lowest temperature heat network which does not require local boosting should not be lower than 55 °C to allow supply of domestic hot water (currently used in Denmark). However, to allow this consultation with public health authorities is required as such a system may require chemical dosing to comply with UK regulations on control of Legionella.

8.3 System operation

Control of systems with multiple input temperatures is difficult, particularly for small systems. An alternative may be that secondary heat systems are connected to buildings locally, with higher temperature sources used to provide peak load via a more centralised heat distribution system. The use of centralised or decentralised heat pumps can only be resolved on a case by case basis. Similarly the balance between peak lopping heat sources or thermal storage is project specific.

Important factors for further study include resilience and programme for network delivery as well as the associated economic cost and carbon impact. A city wide roll out of heat pumps will increase the peak demand for electricity significantly and require significant reinforcement of electrical networks, particularly at local level. The optimal balance between electricity network

reinforcement and the use of heat networks should be investigated in detail to understand the least cost solution capable of providing low carbon heat supplies.

8.4 Emerging areas and pilot study area

The pilot area study suggests that there is an opportunity to develop secondary heat sources in conjunction with the proposed Thames Gateway Heat Network, particularly the section around the Royal Docks. Any further work to develop this network should include secondary heat sources, and the opportunities associated with operating this network at lower temperatures.

Heating and cooling demand estimates used for this study are based on typical building performance. The information available in relation to building heat systems, their configuration and performance is only available through site visits and data collection outside the scope of this study. To ensure a low temperature heat system works effectively better data is required on the ability of buildings in the area to utilise secondary heat at low temperatures. Specifically, better data on building thermal efficiency, heating systems and heat emitter size is required.

The supply sources to connect are also subject to high commercial risk. Discussions should be had with the relative stakeholders to assess the true feasibility of connection to specific sites.

APPENDIX A – Scenarios

SCENARIOS

Business as usual (BAU) – low

Co-ordinated - medium

Ambitious - high

DATA

	2010	2030			2050		
	BAU	BAU	Co-ordinated	Ambitious	BAU	Co-ordinated	Ambitious
Electricity price (£/kWh)	0.071 ¹	0.101 ¹	0.121 ²	0.141 ³	0.101 ¹	0.121 ²	0.141 ³
Gas price (£/kWh)	0.019 ¹	0.02 ¹	0.032 ²	0.044 ⁴	0.02 ¹	0.032 ²	0.044 ⁴
Grid Carbon - electricity consumed (kgCO₂/kWh)	0.542 ⁵	0.542 ⁵	0.104 ⁷	0.104 ⁷	0.542 ⁵	0.023 ⁷	0.023 ⁷
Grid Carbon - gas consumed (kgCO₂/kWh)	0.185 ⁶	0.185 ⁶	0.185 ⁶	0.176 ⁸	0.185 ⁶	0.185 ⁶	0.176 ⁸

REFERENCES

[1] **DECC low scenario for Industrial Retail values.** DECC. Updated Energy and Emissions Projections - October 2012

[2] **DECC central scenario for Industrial Retail values.** DECC. Updated Energy and Emissions Projections. Annex F: Price and growth assumptions - October 2012

[3] **DECC high scenario for Industrial Retail values.** DECC. Updated Energy and Emissions Projections. Annex F: Price and growth assumptions - October 2012

[4] **DECC high scenario for Industrial Retail values.** DECC. Updated Energy and Emissions Projections. Annex F: Price and growth assumptions - October 2012

[5] **Five-year rolling average grid electricity carbon factor.** GHG conversion factors for company reporting, Table 3C, <http://archive.defra.gov.uk/environment/business/reporting/pdf/101006-guidelines-ghg-conversion-factors.pdf>

[6] **Natural gas carbon factor** (DECC / DEFRA, 2012) GHG conversion factors for company reporting, Table 3C, <http://archive.defra.gov.uk/environment/business/reporting/pdf/101006-guidelines-ghg-conversion-factors.pdf>

[7] **DECC Marginal emissions factor.** Valuation of energy use and greenhouse gas emissions for appraisal and evaluation, Box2.B, Table 1, 2011

[8] **Assuming 5% 'green gas' as proportion of natural gas supplied**

APPENDIX B – Heat source Infrastructure Costs

Secondary heat source	Heat pump size (kW)	TOTAL CAPEX	Breakdown of capital costs				
			Heat pump	Ancillary equipment	Pumping equipment	Plate heat exchangers	Building works costs
Ground source - open loop	378	£411,600	£378,000	included in total	included in total	included in total	£33,600
Ground source - closed loop	288	£465,600	£432,000	included in total	included in total	included in total	£33,600
Air source	12,000	£5,651,000	£5,000,000	£0	£16,000	£40,000	£595,000
Air source with storage	12,000	£5,666,000	£5,000,000	£15,000	£16,000	£40,000	£595,000
River source	20,000	£7,255,600	£6,700,000	£10,000	£16,000	£40,000	£489,600
Large Power station heat rejection	20,000	£7,245,600	£6,700,000	£0	£16,000	£40,000	£489,600
Building HVAC - Offices	500	£249,800	£200,000	£0	£1,200	£15,000	£33,600
Industrial sources	-	£216,200	-	£200,000	£1,200	£0	£15,000
Commercial buildings non-HVAC - Supermarkets	500	£209,800	£160,000	£0	£1,200	£15,000	£33,600
Commercial buildings non-HVAC - Data Centres	3,000	£1,492,400	£1,050,000	£0	£4,000	£10,000	£428,400
Water treatment works	20,000	£7,245,600	£6,700,000	£0	£16,000	£40,000	£489,600
London Underground	50	£71,000	£40,000	£15,000	£1,000	£0	£15,000
National Grid electrical infrastructure	1,300	£641,300	£550,000	£0	£1,800	£5,500	£84,000
UKPN	250	£149,200	£120,000	£0	£1,000	£3,000	£25,200
Sewer heat mining	500	£280,400	£200,000	£40,000	£1,800	£5,000	£33,600
Counterfactual case (4 MW gas boiler)	-	£113,224	-	£65,000	£4,000	£10,000	£34,224

APPENDIX C – Marginal cost of heat curves

London wide marginal cost of heat vs. available capacity - BAU 2010

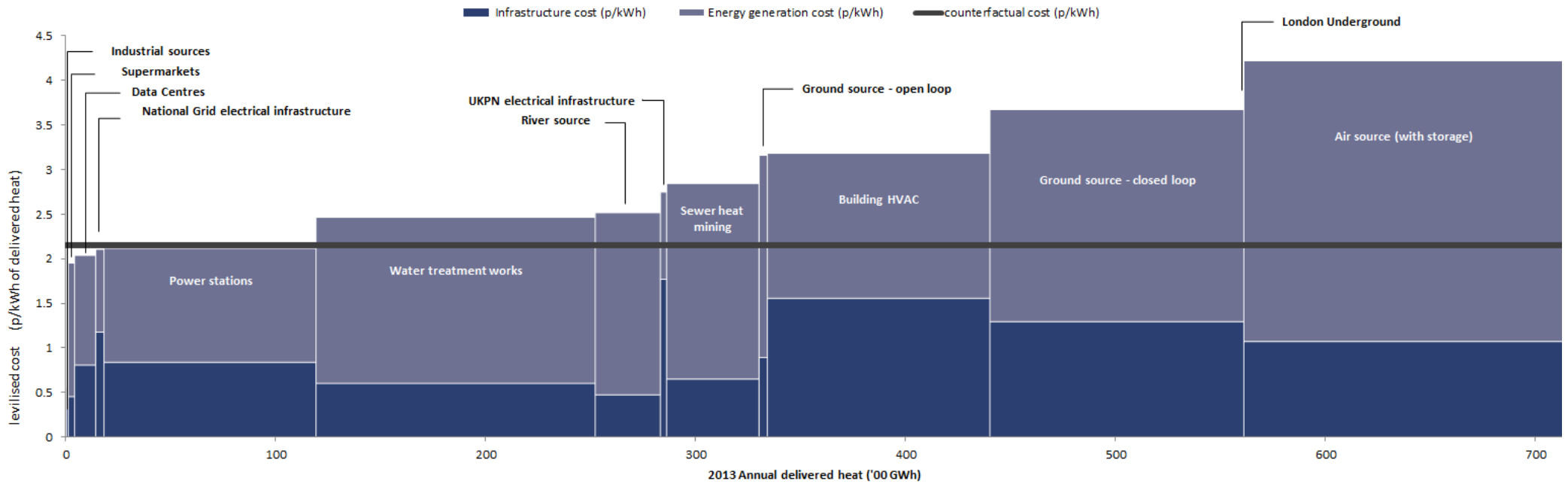

Pilot area marginal cost of heat vs. available capacity - BAU 2010

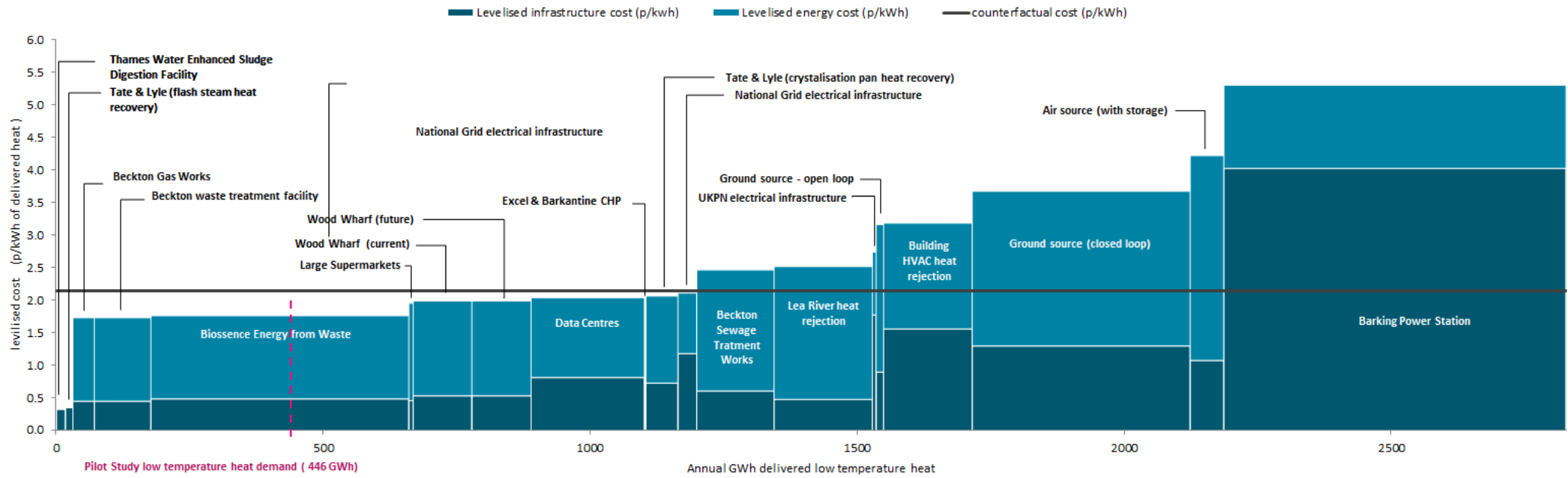

APPENDIX D – Comments on Poyry Heat Pump Technical Assessment (COWI)

Comments on the Poyry Report “GLA Depdu Support - Islington Bunhill Low Temperature Heat Study, Heat Pump Technical Assessment (14 September 2012)”

The report assesses the potential to utilise waste heat from two sources (a London Underground ventilation shaft and a UKPN substation) to provide heat to two areas. The report has been reviewed on a stand-alone basis without prior or further knowledge of the wider network and area of analysis.

From the report it is understood that phase 1 is an existing area which already has a district heating system (assumed to be using CHP as a prime heat source). Phase 2 is a new build area. Although no specific details of the mix of buildings are available, it is assumed that phase 2 is largely residential. The mix of buildings in phase 1 is unknown.

The existing district heating network in phase 1 has been designed with flow and return temperatures of 95/75 °C. Although it is outside of the scope of the Poyry report to comment on the existing network, it should be noted that a return temperature of 75°C is high for a network with a CHP since the operation of the CHP will be less efficient with higher return temperature. We would expect a return temperature of approximately 55°C. It may be possible to make considerable savings in efficiency by reducing the return temperature from the buildings by making simple changes to the heat distribution systems within the buildings. We would recommend a dialogue with the building owners and operators to see if this can be achieved.

Poyry have been commissioned to assess the resource available from the two sources and advise on how it may be utilised within the network. They have suggested that heat pumps could be used to raise the temperature of the heat input from the sources, which could then be used in the network. It is suggested that the network in the phase 2 area is run at a flow/return temperature of 60/45°C, whereas in the phase 1 area the network will continue to be run at the design temperatures. It is suggested that both parts of the network can be hydraulically connected and that the heat pumps will be connected in the low temperature area with the CHP being connected in the high temperature area.

Whilst the conclusions reached by Poyry are theoretically correct and work on paper, from experience we would suggest a more holistic approach to reach an overall solution which is practical and provides adequate heat for all connected to the network. We therefore have the following comments and additions to Poyry's analysis:

We agree that the use of heat pumps to upgrade the heat from the waste heat sources can be an efficient way of supplying heat to a district heating network. The source of the electricity used to drive the heat pump should be renewable if possible to ensure low carbon intensity. This could supply a sustainable source of zero carbon heat to the network when there is renewable resource available. See the case study on Frederikshaven for an example of how this can work in practice.

It is noted by Poyry that there will be a neutral point which will move according to load variations. From experience we note that the location of this point will be constantly varying, which makes control of the network very difficult and in some cases impossible. With a small network (and depending on the customers connected) the load variation could make this point vary significantly,

potentially causing issues for other customers. For example, should a large heat user start drawing from the network the pressure will drop suddenly, which could mean that some customers in the middle of the networks receive water at a much lower temperature than is optimal.

Knowledge of the loads on the network and the consumers use of heat over time is key to enabling effective control. A dialogue with large users is very helpful to determine the equipment that is connected (to assess the maximum instantaneous heat consumption) and to suggest ways to smooth the heat consumption. For example, in some cases simple adjustments to the building control systems to stagger when buildings take maximum heat can help to reduce the overall instantaneous draw of heat from the network. This can help minimise the variation of the neutral point on a multi temperature network and therefore assist in control.

Poyry mention that it is possible that the temperature could be turned down in the existing network, certainly during the summer months. We suggest that this option is explored in greater detail since it may provide significant savings. Studies carried out in Denmark on existing district heat networks serving residential areas have shown that it is possible to reduce the flow temperature on a network originally designed for a flow temperature of 95°C to 60°C throughout the year without detrimental effects to the thermal comfort within the dwellings. Without details of the buildings connected to the network it is impossible to assess whether this can be done in this case, but it is recommended that it is given further consideration as an opportunity.

Should the overall temperatures be reduced as suggested it would be possible to run the whole network at a constant temperature. This would allow easier control whilst still providing enough heat to those connected. It would also mean that heat pumps could be used more efficiently to contribute heat to the network from low temperature sources as the temperature would not need to be increased so much by the heat pump.

The physical locations of the heat sources and demands are not known. It may be the case that connections to the network in the manner described are impractical or make utilisation of the heat source economically unviable. Poyry mention that the location of back up plant should be carefully considered and we would stress that this is a very important point when considering the development of the network since its location will have significant effect on the hydraulics of the network.

Although the report explains the technical methods of utilising the waste heat, it does not give a holistic view of the entire network. Whilst we recognise that Poyry have carried out their brief to supply the technical information required we caution the overall methodology of looking at heat sources in isolation. We do, however, note that we have been asked to comment on this report in isolation, with no prior knowledge of work carried out in this area. It is possible that this report forms a small part of the assessment of the overall project, to which we have not been involved.

The physical location of the heat sources and demands are extremely important, particularly when there are a number of diverse sources at different supply temperatures. The Poyry report gives a good explanation of how the heat sources may be utilised and we would suggest that further assessment of the location of sources and demands is carried out, if this has not already been done.

Although it is possible to provide heat to a network from sources of different temperatures, we would usually advise against it for a small network. In a large network where there are many thousands of connected heat users, the demand is much more consistent and variation doesn't

have such an impact. However, on a small network, these fluctuations could lead to serious issues with control and unacceptable fluctuations in the supply temperature to customers.

However, that is not to say that it is not possible to manage a small network with different temperature profiles. Much will depend on the type of connected loads, the interaction with consumers and the control methods for the network. If the loads can be smoothed to reduce significant fluctuations on the network it may be possible to supply adequate heat to all users with different parts of the network at different temperatures. The key consideration is to assess how much the neutral point could vary and which buildings could be affected by the variation. This information can help to provide a view of the risks of running the network in this way and aid decision making on the final design.

Without a full view of the proposed network it is impossible to suggest a definitive solution that will definitely work in practice. However, given the information provided we suggest exploring the following two options further:

- Possibility of turning down the temperature in phase 1 so that the entire network operates at the same temperature and heat sources input at this temperature. As mentioned, studies in Denmark have found that, depending on the types of buildings connected, it is often possible to reduce the temperature of an existing network significantly without detriment to connected consumers.
- Running the networks as two separate areas with different temperatures and hydraulic separation in the form of a sub station between them (containing a mixing station and pumps). The high temperature network could still be used to supply heat where necessary to the low temperature network, but this approach may improve the ability to control the entire network.

We also recommend that a holistic overview of the opportunities for future development is taken with particular emphasis on the physical location of heat sources and loads in the area to assess the impact of a moving neutral point. This will help to provide a quantitative view of the risks associated with operating a network with more than one temperature and assist with decision making.

APPENDIX E – Comparison of ambient temperature energy sharing networks

Comparison of ambient temperature energy sharing networks vs. conventional and low temperature district heating networks (by DEC Design)

District energy sharing concept

A district energy sharing system utilises a warm and cool pipe to share low grade thermal energy between buildings. Each building has a heat pump (which can be reversible) to provide heating (or cooling) at the required temperature. See Figure D.1 which explains the concept.

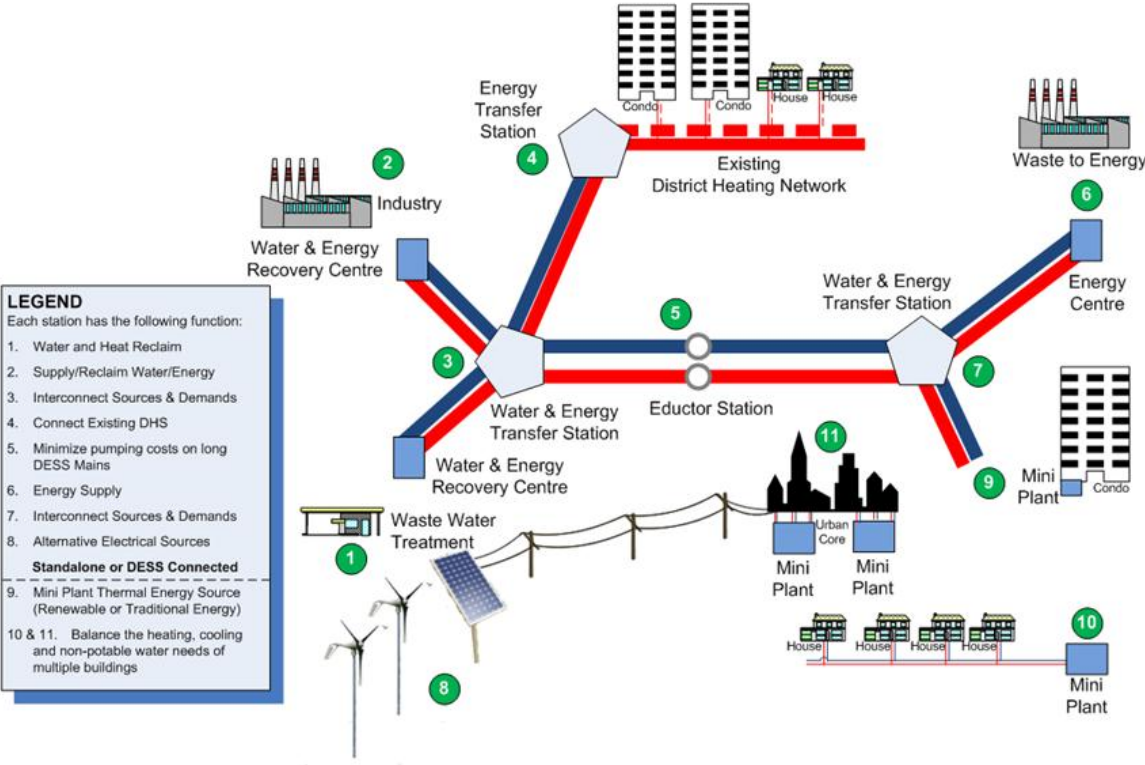

Figure D.1 – Overview of the concept for a district energy sharing system

Comparison of ambient systems and district heating systems

DEC Design has spent considerable time and energy over the last 8 years analysing the differences between low temperature ‘ambient’ DESS systems and typical high temperature DHS systems. As an engineering firm capable of designing both systems it has always been our responsibility to recommend the system that best suits the location, economics and needs of our client.

Our modelling and review of the provided cases studies has shown that

District Heating Systems can be:

- Well suited for high density population centres that maintain high occupancy throughout the year
- Best suited for high density population centres in close proximity to sources of waste heat

- Very sensitive to variations in building occupancy and seasonal fluctuations in temperature that result in reduced heat load for the central heat plant and reduced efficiency of the central heat plant
- Difficult to stage with the development of purpose built heat sources in a manner that matches capital costs to utility revenues without securing thermal energy contracts with existing buildings in the general vicinity; and
- Easily combined with ambient temperature systems to optimize the delivery to a dense population centre

Ambient Systems can be:

- Well suited for managing the efficient energy distribution throughout the loop to the energy delivery needs within the building for heating and cooling and domestic hot water;
- Best suited for minimizing capital costs through the use of low cost equipment (heat exchangers and heat pumps), relative to more expensive heat pumps required for a high temperature systems;
- Able to bring the combined COP of the DES to over 4.5, as compared to high temperature systems that offer a COP of under 2.5;
- Able to minimize the costs of the loop equipment (heat pumps and heat exchangers) by minimizing the output temperature for the loop;
- Able to minimize the capital and operating costs of building heating and cooling systems, including recovering heat from cooling;
- Can be combined with high temperature systems to optimize the capital costs of energy extraction and distribution; and
- Able to better match the total cost to revenue as renewable energy sources can be added incrementally to suit demand.

Table D1 summarizes some of the key differences between a low temperature (ambient) district energy sharing system and a high temperature (above 100 °F) district energy system.

Table D1 - Comparison of district energy sharing and district heating system characteristics

	Ambient temperature DESS	District heating system
Operating Temperatures	Warm pipe: 10 °C - 35 °C (50 – 95 °F) Cool Pipe: 5 °C - 25 °C (40 – 77 °F)	Supply: 65 °-95 °C (150 – 203 °F) Return: 45 °C - 55 °C (113 – 131 °F)
Operating Pressures	2 – 8 bar (30- 120 PSI)	15 – 25 bar (230 - 360 PSI)
Equipment Requirements	Building Heat Pumps Building or ETS Boilers Circulating Pumps	Central Boilers Circulating Pumps Heat Accumulators
Piping	Inexpensive HDPE (Lifespan approximately 50+ years)	Thermally insulated steel/pex pipe
Special Building Design Requirements	None. Heat pumps or water source VRF condenser and boilers are sized by	Buildings must be designed for a high delta T to ensure efficient operation of

	building to maximize building efficiency and minimize building costs	the central heat plant (this is not always possible or practical)
Connection of Alternative Energy	Alternative energy sources can be connected either directly using a heat exchanger or through a heat pump operating at a high COP (5 – 7)	Alternative energy sources can be connected by a high temperature heat pump running at a low COP (2 – 3)
Energy Sharing Capacity	Any building in heating mode rejects cold water that can be used for cooling. Any building in cooling mode rejects energy that can be used for heating. A single building can be in a state of cooling and heating simultaneously, further reducing operating costs.	None
Cooling	Building heat pumps can cool directly with no added equipment costs. The heat reject from cooling can be used elsewhere for heating further reducing operating costs	No cooling ability therefore cooling equipment must be installed at additional cost
Energy loss	Insignificant energy loss in piping	Requires thermally insulated pipe due to high energy losses. Thermal losses are still present.
Utility Revenue	Space heating, DHW heating and space cooling	Space heating and DHW heating
Percentage of energy supplied by alternative energy	~85% (depending on availability of waste heat)	~60-80% (can be higher where sufficient renewable energy is available to meet peak loads e.g. energy from waste)

APPENDIX F – Pilot study district energy sharing system

Pilot area study – district energy sharing system (DEC Design)

A conceptual DESS was developed for the pilot area study. Due to the large areas involved, the DESS pipe routing was designed with modular build out in mind thus allowing incremental additions to the network as sections are completed in phases. A DESS can be installed as a series of independent network loops that are interconnected to provide surplus heating from one loop to another. This approach reduces the distribution pipe size, provides greater network reliability, and allows for extended buildout timelines without negatively affecting loop performance.

The following concept focuses on two subsections of the study area identified for their high compatibility with a low-temperature, distributed heat pump heating system. These subsections are:

- Canary Wharf Area
- Royal Docklands Area

As the above subsection DESS networks are nearing completion, the opportunity exists to connect the two subsections into a larger, area-wide DESS as well as integrate additional energy loads and sources as needed. Several large, high compatibility energy sources exist to the east of the study area including Beckton Sewage Treatment Facility, Barking Power Station, and Bioessence Energy. These sources could be added incrementally as build out progresses and capacity becomes necessary.

The ambient District Energy Sharing Concept Design concept is based on minimizing the overall energy supply into each precinct of a DESS network by enabling buildings with surpluses in heat (cooling) to provide that energy to buildings with a net deficit of heat, and vice versa. By doing this the precinct can reduce its overall energy (natural gas) supply requirements by 40%.

To accomplish this, Energy Transfer Stations will be required to be connected to one or more buildings and to the DESS.

Where buildings have both a source of heating (e.g. boilers) and cooling (chillers), heat pumps may be added to provide both simultaneous heating and cooling, reducing the overall build energy demand. This will reduce the operating costs of the building, even before connecting to a DESS network. This will also reduce the supply capacity of the DESS and the overall network cost.

Table E1 - Summary of Concept

Component	Concept
Simultaneous Heating and Cooling	Heat pumps are used to enable a building to look after its own internal heating and cooling needs.
DESS Energy Supply	Buildings only draw from the DESS plant when there is a net deficit in heating or cooling.
Supplemental Heating	Supplemental heating is made up by the buildings’ existing boilers
Supplemental Cooling	Supplemental cooling is made up by the buildings existing chillers

DESS Delivery	Energy Transfer Stations are used to interconnect one or more buildings
DESS Distribution	Energy Transfer Stations are interconnected to form DESS grid where the overall distribution pipe size can be standardized (and minimized).

On the DESS delivery side of the ETS, the delivery temperatures are modulated to meet the buildings' needs for heating and cooling and directly exchange with the existing building systems. This allows the existing building heating and cooling systems to be used for peak and backup thermal energy requirements, and minimize the risk to the building owner.

In preparation for a DESS; ETS can be setup as standalone mini-plants to help one or more building owners reduce their overall energy supply requirements, and resulting operating costs. When the DESS is available, these mini-plants can be interconnected, forming a grid of one or more zones. DESS energy source is then sized to meet the optimal percentage of the one or more DESS zones net demand for heating and cooling.

Design Considerations

The following principles and assumptions should be applied to the final design of a DESS for each precinct.

Understand the building heating and cooling loads and install ETS (or mini-plants) to meet the optimal recovery of energy from one or more buildings

A detailed building load analysis should be performed for each high heating/cooling demand load within a DESS zone. Using this information, the capacities of the ETS (or mini-plants) will be selected to optimize the cost of installed capacity with the existing (supplemental) heating and cooling.

Distribution Costs

This consideration affects the temperature and type of distribution system. Typically, ambient district energy system distribution costs are 60% to 75% of the cost of a district heating distribution system. However, in London where there are more complex and higher trenching costs, this cost increase may offset the capital cost advantage enjoyed by an ambient temperature distribution system.

Assess the electricity and natural gas rates to provide heating and cooling in the most cost effective manner

A DESS requires heat pumps to run for all heating and some cooling loads, whereas a DHS uses a heat exchanger to do direct heating. Therefore, particular attention needs to be paid to the heat pump Coefficient of Performance (COP). For ammonia based heat pumps, COP's as high as 7-9 are possible. However, for more conventional heat pumps with R410a, COP's of 4 to 6 are more typical. For the purposes of this report, a COP of 4 has been used.

Include heating redundancy

Since the ETS (and mini-plants) are designed to utilize the existing building heating and cooling sources for peak and backup capacity, the DESS system has built in redundancy.

Sewer Plumbing Heat Recovery

For buildings like 1 Canada Square, which have a potable water demand of over 900,000 L per day, the sewer flow leaving the building will likely have a discharge temperature around 20C. If the appropriate black water heat recovery technology were (E.g. www.sewageheatrecovery.com) used and 10C extracted from the plumbing (discharge to the sewer at 10C), and average 370kW may be realized, throughout the day. This is just short of 20% of the DESS building supply of 2MW.

Targeted Study Area Heat Loads

The identified loads for this study consist of heating fuel consumption for selected buildings of varying typologies located in Newham. The following heating figures have been calculated from annual heating fuel consumption and provided, typical heating benchmarks for London, England. The included building typologies for this study include:

- Private Commercial (>9,999 m²)
- Private Residential (>149 units or 9,999 m²)
- Hotels (> 99 units or 4,999 m²)
- Industrial
- Retail
- Sport and Leisure Facilities
- Education Facilities
- Fire Stations
- Other Public Buildings.

Targeted Study Area Heat Sources

A good variety of sources for heat recovery are available within the study area. These include:

- Heat Recovery from Building HVAC (including Residential, Commercial, and Hotel)
- Heat Recovery from CHP (at sites such as Excel or Barkantine)
- Heat Recovery from Industrial Process (i.e. Tate & Lyle Refinery)
- Heat Recovery from Commercial Non-HVAC Heat Rejection (i.e. Data Centers).

Total Supply and Demand Forecasts

A significant advantage of a DESS is the ability to take advantage of local sources of low-grade thermal energy. Heat recovery from HVAC systems can provide a significant portion of an area's net heating demand. Based on available data for a selection of sites within the proposed study area, net heating demand and net thermal energy from HVAC heat recovery have been calculated on an annual basis. This calculation provides a high level analysis of net annual thermal energy demand and supply for building heating and cooling.

Building heating and cooling loads have been extrapolated from provided fuel consumption data for the Tower Hamlets. Heating benchmarks⁴² were used to determine heating fuel consumption as a percentage of total fuel consumption. London annual energy use intensities (EUIs)⁴³ were then used to calculate annual cooling demand from annual heating demand.

Our assumptions are based on information from the Battersea report (attached) which included EUIs for London. It suggests that the Lean building, "Office" EUI for cooling (18.6 kWh/m²) is nearly twice that for heating (9.7 kWh/m²). This ratio seems within the expected range for office buildings. We used both of these EUIs to estimate annual cooling from annual heating.

In addition to HVAC heat recovery, other heat sources have been included in this analysis. Annual capacities of heat sources in the study area have been supplied. This includes heat recovery from data centers, CHP, and industrial process.

Including these additional heat sources, total thermal energy supply and demand for the two subsections has been calculated.

Canary Wharf

Canary Wharf presents an excellent opportunity for inclusion with a District Energy Sharing System. The office towers have high heating and cooling demands. The site also contains a number of data centers which offer valuable diversity for thermal energy recovery. The site's high density and smaller area (1.8 km²) reduces distribution costs and increases return on investment. Canary Wharf's office towers have a heating and cooling load profile that differs from the residential, industrial, and entertainment spaces connected to the DESS at other locations. Having a variety of building arch types connected to the DESS creates the greatest opportunity for efficiency through energy sharing. Connected to a DESS, Canary Wharf's office towers could prove to be a valuable heat source throughout much of the year.

Due to the cost of connecting a building to a DESS, it was decided to focus the Canary Wharf DESS on those buildings that were large enough to make connection financially viable. Buildings under 1000 MWh/year of thermal energy consumption are excluded from this analysis.

⁴² Buro-Happold, Pilot study area supply source data.

⁴³ *Battersea Report*, September 2010.

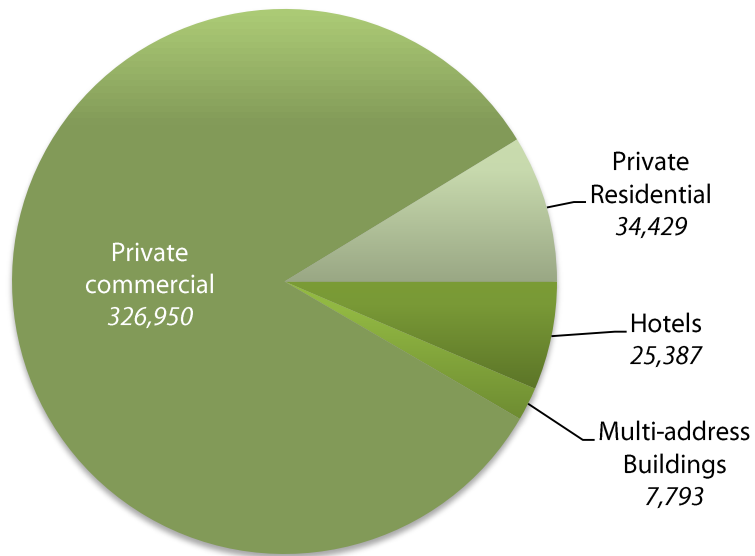

Figure E1 – Canary wharf heat loads (MWh/yr)

The resulting sites in the Canary Wharf subsection present an annual heating load of 394,560 MWh.

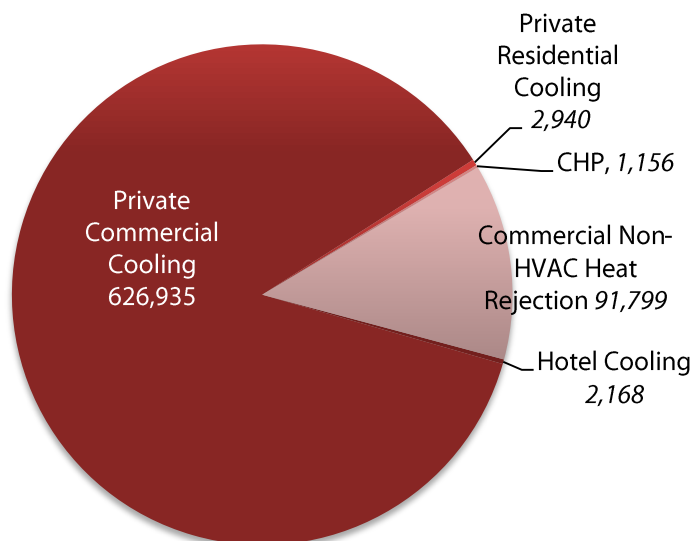

Figure E2 – Canary wharf heat sources (MWh/yr)

Annual cooling demand for Private Commercial, Private Residential, and Hotel typologies was projected from annual heating demand data. The provided Lean building “Office” EUI for cooling (18.6 kWh/m²) is nearly twice the heating EUI (9.7 kWh/m²). This ratio is within the expected range

for commercial typologies. Based on this information, the sites in the Canary Wharf subsection could provide in excess of 724,999 MWh of thermal energy annually.

Barking and the Royal Docks

The Royal Docks is a much larger subsection of the study area (6.2 km²) but contains a valuable variety of heat recovery sources from sites such as Silvertown Quays, Tate & Lyle Refinery, and Excel Center CHP. In addition, the extensive development planned for the area could facilitate integration of future loads and sources with a DESS through proper design and selection of heating and cooling systems. This analysis includes current and projected fuel consumptions for existing sites and proposed developments.

Based on the provided data for heating fuel consumption in the Royal Docklands area, the following breakdown of energy demand by typology has been created. This breakdown excludes the Tate and Lyle heating fuel consumption of 778,729 MWh/year. This load is of such great magnitude that a more detailed analysis of how to integrate Tate & Lyle as an energy consumer should be undertaken.

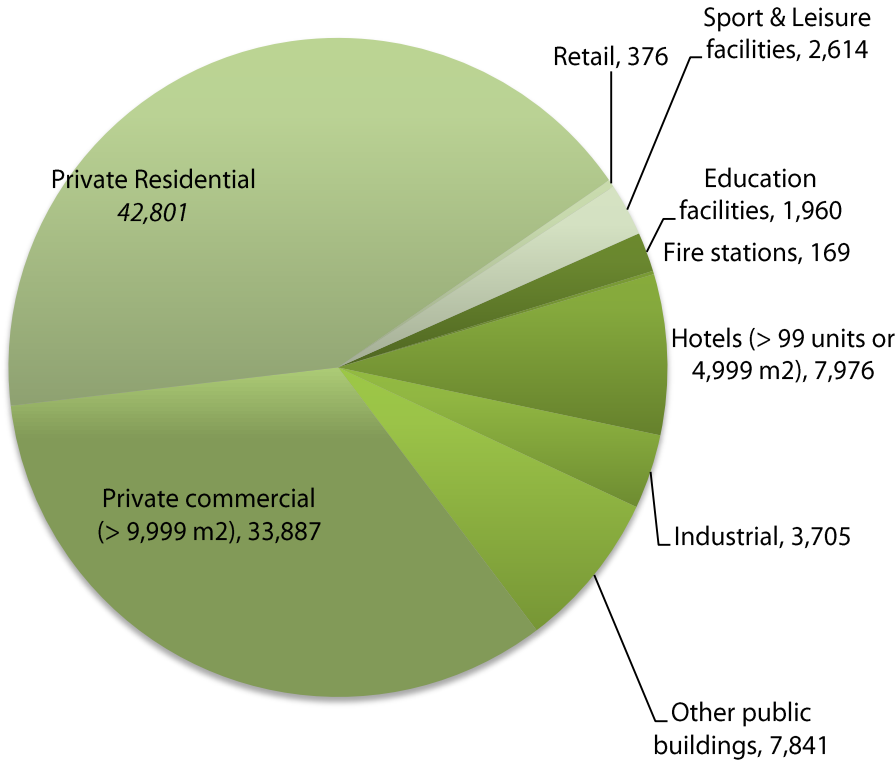

Figure E3 - Barking and Royal Docks heating loads

Based on the annual heating loads and typologies for the sites included in the Royal Docklands Subsection, annual cooling loads were calculated. These cooling loads can be valuable heat sources if connected to a DESS. Other heat sources in the subsection, identified for inclusion within

a DESS, are the Excel Center CHP and Industrial Process Heat Recovery from the Tate & Lyle Refinery. The Royal Docklands heat sources are summarized in the following table.

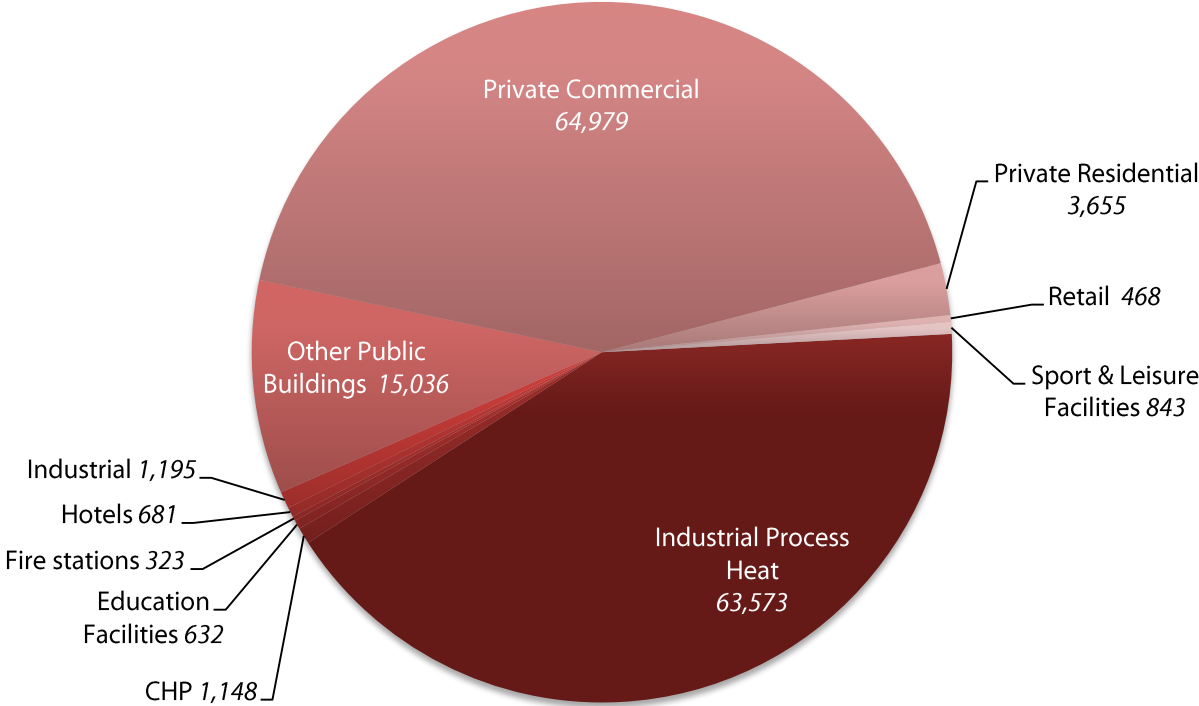

Figure E4 – Royal docks heat sources (MWh/yr)

Annual Energy Profile

One of the advantages to DESSs is their ability to take advantage of simultaneous heating and cooling demands, reducing the need for thermal storage, and resulting in increased efficiency. For this reason, an expected annual heating and cooling demand profile for typical buildings in the site has been created to calculate simultaneous heating and cooling loads.

An annual hourly heating and cooling demand profile for a new office building in Vancouver, BC was used to model the projected hourly heating and cooling demands profile for the office towers in Canary Wharf (those sites categorized as “Private commercial (> 9,999 m2)”). Similarly, an annual hourly heating and cooling demand profile for a new residential tower in Vancouver was used to model the residential, hotel, and multi-address typologies of Canary Wharf.

It has been assumed that data centre, CHP, and industrial process heat recovery sources operate at a consistent output level throughout the year providing a baseline heat source.

From these hourly profiles, peak heating demand, equipment sizing, and expected levels of energy sharing have been projected.

Canary Wharf

Using the typical energy use profiles for buildings within Canary Wharf, the peak heating and cooling loads were estimated, as well as the ideal DESS equipment sizing. This information is outlined in the Table below.

TableE2: Canary Wharf DESS Annual Energy

Peak Heating	742	MW
Annual Heating	394,551	MWh
Peak Cooling	956	MW
Annual Heat Rejection	632,043	MWh
DESS HP Connection as % of peak Heating	10%	
Peak DESS Heating Load	74	MW
HP Heating Output	194,317	MWh
HP Heating as % of annual heating	49%	
Total Cooling Recovery	145,738	MWh
Data Centre and CHP Cooling Recovery	18,055	MWh
HVAC Cooling Recovery	127,683	MWh
Heating Surplus (if DESS were expanded)	235,112	MWh

The site has a peak heating demand of 742 MW and peak heat rejection of 956 MW. Currently, these peak heating and cooling loads are provided by boilers and chillers installed in each building. Given this existing equipment, the DESS connection can be sized for only a fraction of peak demand. Any demand in excess of the DESS capacity is made up by the existing boiler and chiller systems. Existing heating and cooling systems also provide full redundancy in the event of malfunction. By sizing DESS equipment for a fraction of peak demand, capital costs are dramatically reduced while still providing a significant proportion of annual heating load.

The Canary Wharf Subsection DESS equipment capacity has been sized to efficiently deliver energy from sharing. The Maximum Energy From Sharing is limited by either:

- The energy available(MW) from all sources in the subsection at any given hour
- Then energy demand (MW) from all loads in the subsection at any given hour

As DESS equipment capacity is increased, an increased amount of annual energy can be delivered up to the maximum energy available for sharing (energy supplied for which there exists a sufficient

load). The relationship of equipment size to annual energy delivered is illustrated in the following chart.

Figure E5 - Canary Wharf DESS Equipment Size

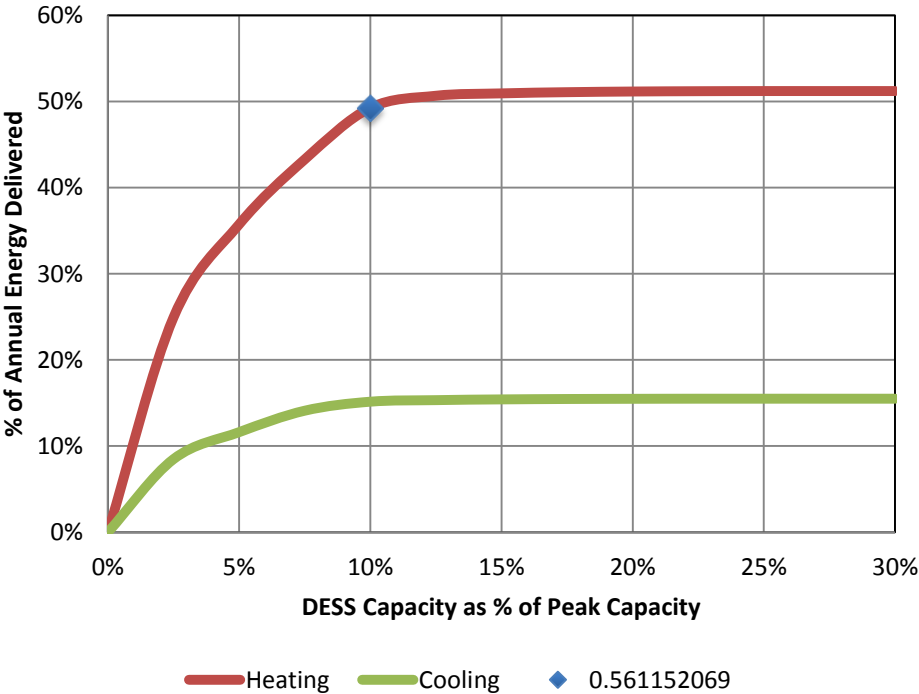
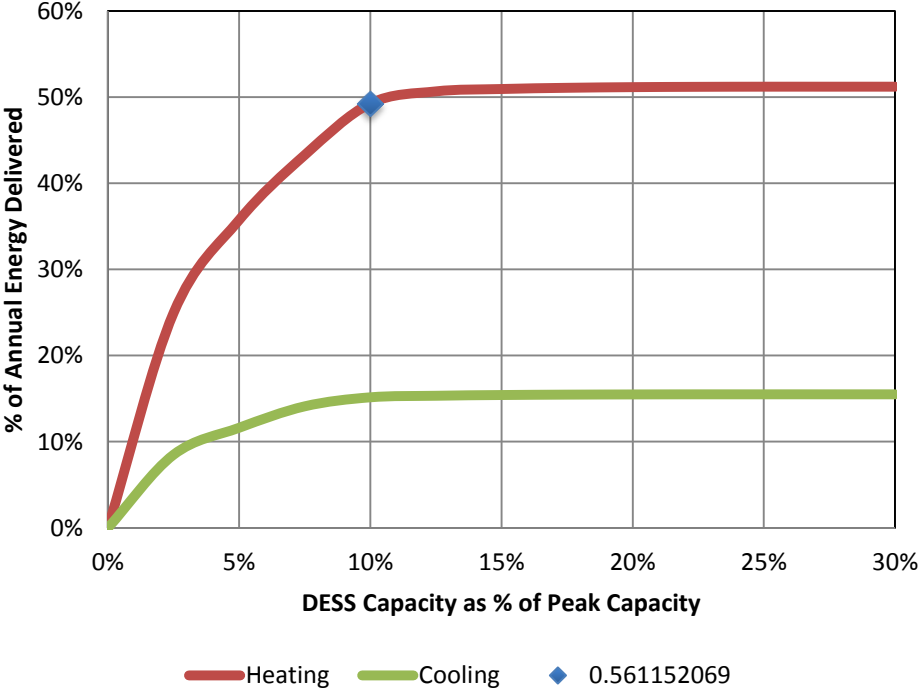

Based on our analysis, the optimal size for DESS Equipment Capacity would be 10% of the Canary Wharf Subsection peak demand or 74.2 MW. Even with equipment of this small size, the DESS would be able to deliver 49.3% of the subsection annual heat demand through sharing.

Royal Docklands

This subsection presents a greater diversity of building typologies than Canary Wharf. A similarly diverse, urban development in Vancouver, BC consisting of primarily commercial and residential typologies with smaller amounts of retail, community, and hotel typologies was used to model the annual energy use profile of the corresponding typologies in Canary Wharf, excluding industrial and CHP heat recovery sources which were assumed to be constant output levels through the year.

Using the modelled energy use profiles for buildings within Royal Docklands, the peak heating and cooling loads were estimated, as well as the ideal DESS equipment sizing. This information is outlined in the Table below.

Table E 3 - Royal Docklands DESS Annual Energy

Peak Heating	89	MW
Annual Heating	101,330	MWh
Peak Cooling	107	MW
Annual Heat Rejection	87,814	MWh
DESS HP Connection as % of peak Heating	23%	
Peak DESS Heating Load	20	MW
HP Heating Output	67,752	MWh
HP Heating as % of annual heating	67%	
Total Cooling Recovery	50,814	MWh
Data Centre and CHP Cooling Recovery	19,867	MWh
HVAC Cooling Recovery	30,947	MWh
Heating Surplus (if DESS were expanded)	90,250	MWh

Royal Docklands has greater diversity in heating and cooling demand profiles than Canary Wharf (primarily due to the larger floor area of Residential typologies). This diversity allows for a greater amount of energy sharing as a percentage of peak heating and thus proportionally larger DESS equipment as a percentage of peak heating. The relationship of equipment size to annual energy delivered is illustrated in the following chart.

Table E4 - Royal Docklands DESS Equipment Size

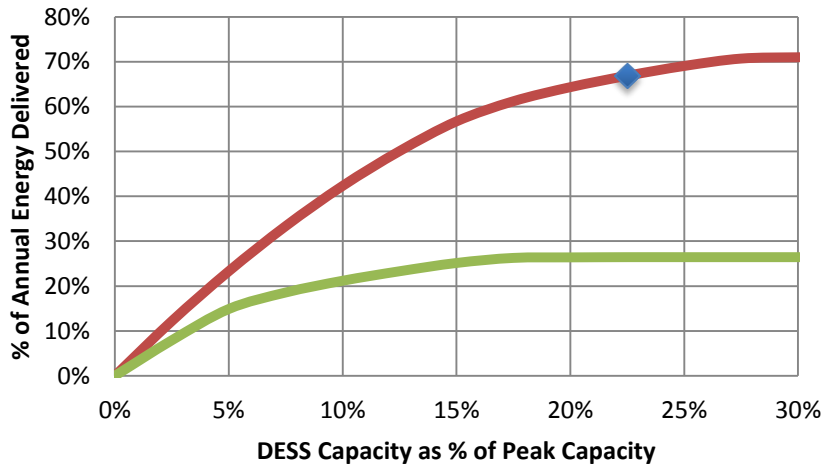

— Heating — Cooling ◆ Design Point

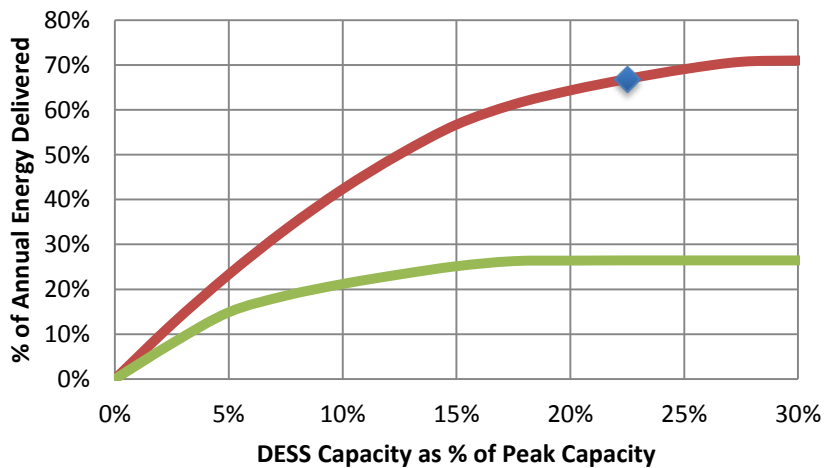

— Heating — Cooling ◆ Design Point

Based on our analysis, the optimal size for DESS Equipment Capacity would be 22.5% of the Royal Docklands Subsection peak demand or 20 MW. Even with equipment of this small size, the DESS would be able to deliver 67% of the subsection annual heat demand through sharing.

Concept Schematic Design

Two types of DESS Energy Transfer Stations (ETS) have been identified based on the characteristics of the connecting load or source. A high level schematic of the DESS and ETS concept is under development.

Data Centre, CHP, or Industrial Source Heat Recovery ETS

Waste heat recovery energy centers are designed to recovery energy from the following sources:

- Data Centre
- CHP

- Industrial Process

These low-grade heat sources provide supply temperatures ranging from 28 to 45 C which allows for direct heat exchange with the low-temperature DESS. Source heat is assumed to be collected by an existing hydronic cooling system. The waste heat recovery energy centre would tap in to this existing hydronic cooling system passing the cooling fluid through a new heat exchanger and then re-injecting it into the existing system warm line. This reduces or eliminates the cooling load on the existing cooling system. Water from the DESS cool line would be passed through the other side of the new heat exchanger and injected into the DESS warm line (See Figure D1).

An example Data Centre Heat Recovery ETS has been designed for the Control Circle Data Centre located in the Canary Wharf Subsection of the Pilot Study Area. This data centre has an annual heat rejection of 29,187 MWh. Assuming the data centre is in operation 24 hours per day, 365 days per year, it represents a source with capacity of 3.3 MW. The corresponding ETS has been designed to capture 100% of this heat source given sufficient demand exists within the Canary Wharf Subsection DESS. If less than 3.3 MW of demand exists, the ETS will transfer the required energy to the DESS with the existing cooling system rejecting the remainder of the available data centre heat.

Commercial Building ETS

This ETS will be used to connect one or more buildings to the DESS where the buildings require both heating and cooling and thus must be able to connect to the DESS as either load or source. Where buildings have both a source of heating (boilers) and cooling (chillers), heat pumps may be added to provide both simultaneous heating and cooling, reducing the overall build energy demand. This effect of sharing within the building will reduce operating costs, even before connecting to a DESS network. This will also reduce the necessary capacity of the DESS and the associated overall network cost.

For the purpose of this high level study, we have not factored in the effects of internal building energy sharing. Buildings have been modelled as a heat load and source simultaneously. Integration of ETS heat pumps with existing hydronic heating and cooling systems will take advantage of any internal building sharing before placing a demand or supply on the DESS. It is expected that this internal sharing, not modelled, may prove to reduce the necessary distribution capacity and distribution costs of the DESS.

Many modern buildings already employ heat pumps to balance heating and cooling loads. As the existence of these systems is not known for the buildings in the pilot study area, it has been assumed that heat pumps would need to be included as a part of an ETS design. If buildings do have existing heat pumps, then the additional heat pump capacity to be included in the ETS estimate may be reduced or eliminated entirely.

An example Private Commercial Building ETS has been designed for a selected building in the Canary Wharf subsection (1 Canada Square). This building has an estimated annual heat demand of 8,306 MWh (based on an annual fuel consumption of 11,835 MWh and supplied heating benchmarks for London). Assuming 1 Canada Square to have an hourly heating profile equivalent to a similar size new office building in Vancouver BC, the building represents a load with peak demand of 20.3 MW. The corresponding ETS has been designed to provide 10% of this peak load (2.05 MW) given sufficient supply exists within the Canary Wharf Subsection DESS. Existing boilers

will provide backup heating for times when heat demand exceeds 10% of peak heat demand or when sufficient DESS capacity does not exist. Even with this small sizing, the DESS could deliver a projected 51% of the building's annual heating demand.

As a commercial office tower, 1 Canada Square can be a source of heat at times when rejected heat from cooling exceeds the buildings heating demand. At these times, excess heat would be pumped from the building's existing cooling system into the DESS warm line by the ETS heat pumps. Should the available heat from cooling exceed the DESS heat demand, excess heat would be rejected by the existing cooling towers.

Connection of 1 Canada Square with this type of ETS would enable 34% of annual cooling to be provided by the DESS.

APPENDIX G – DESS Loads and Sources Maps

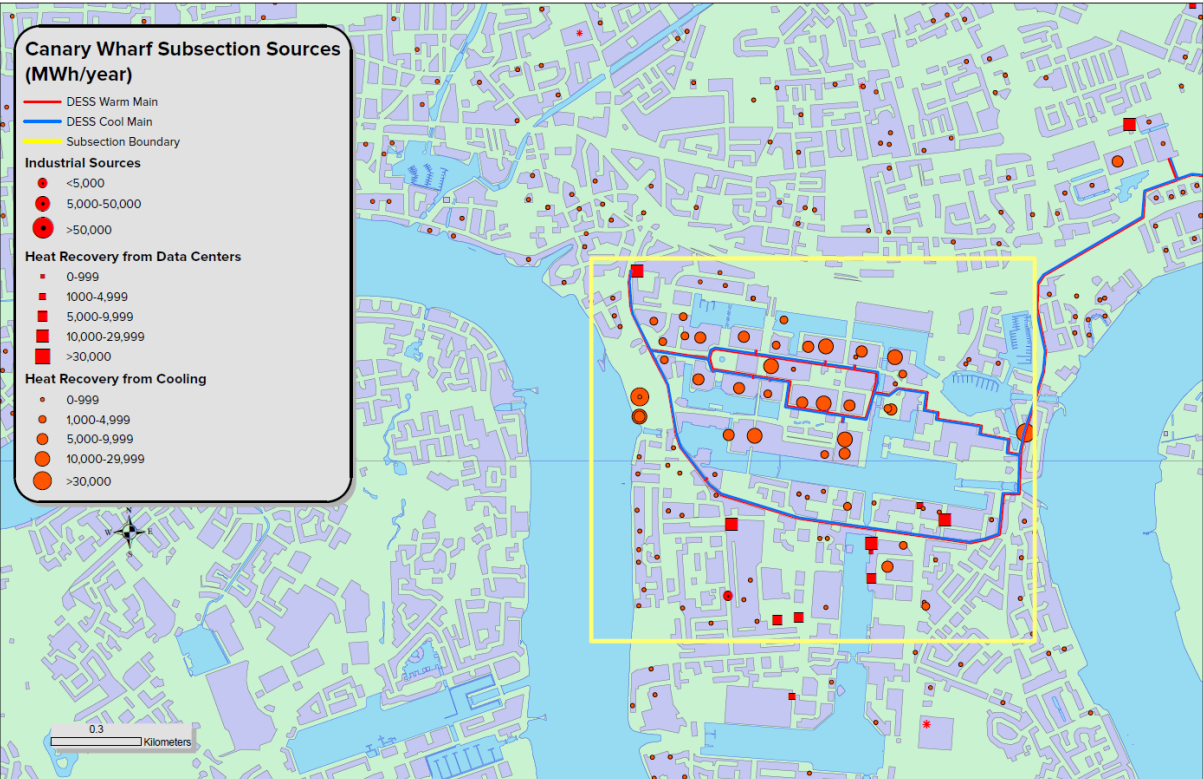
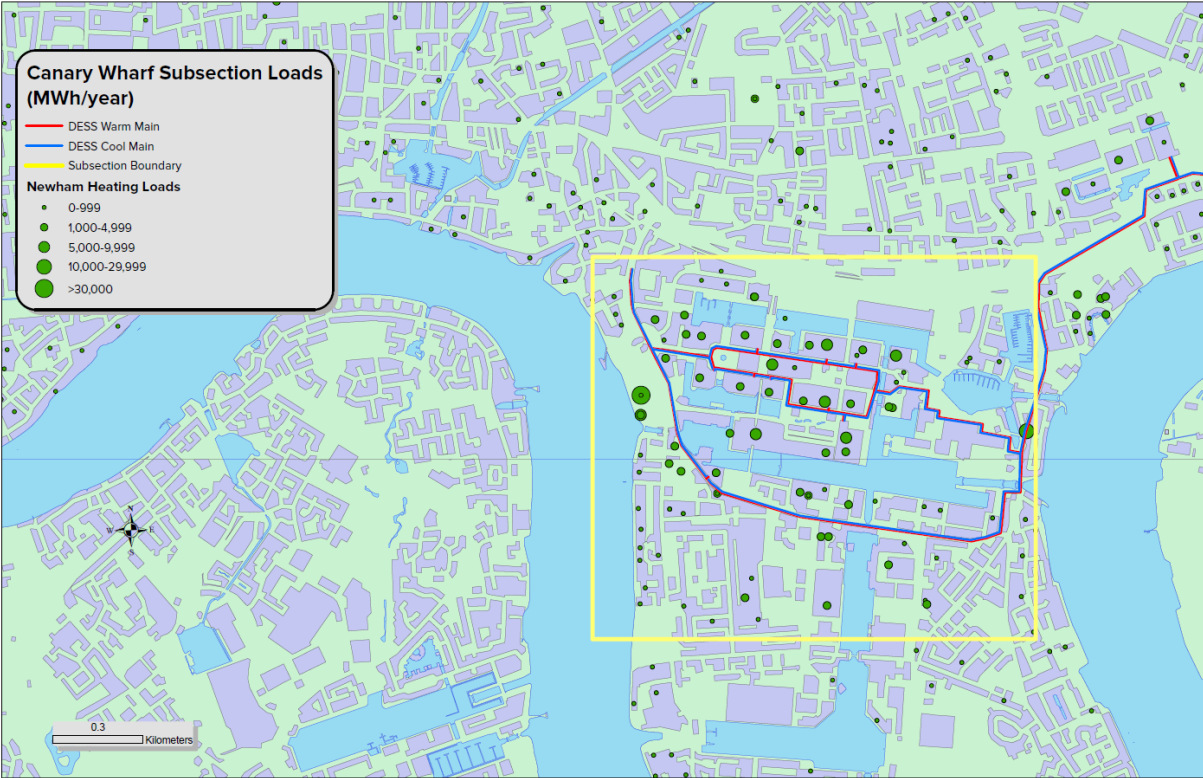

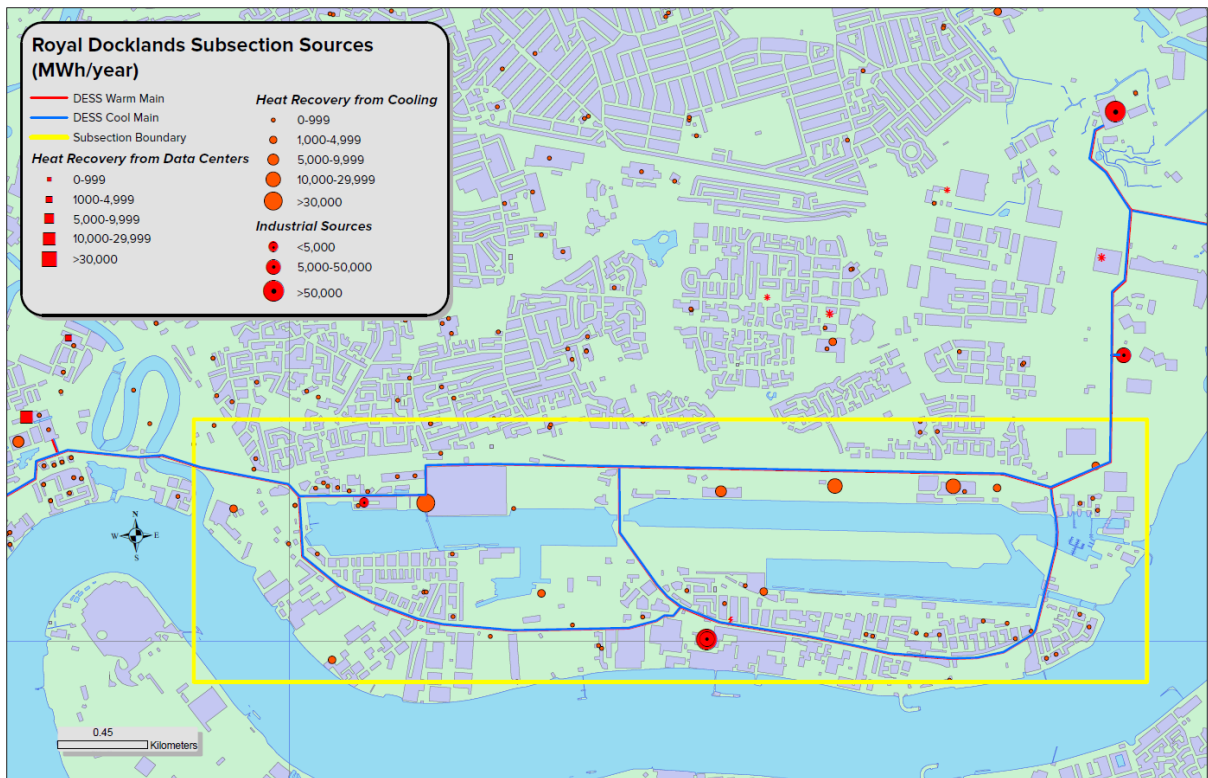
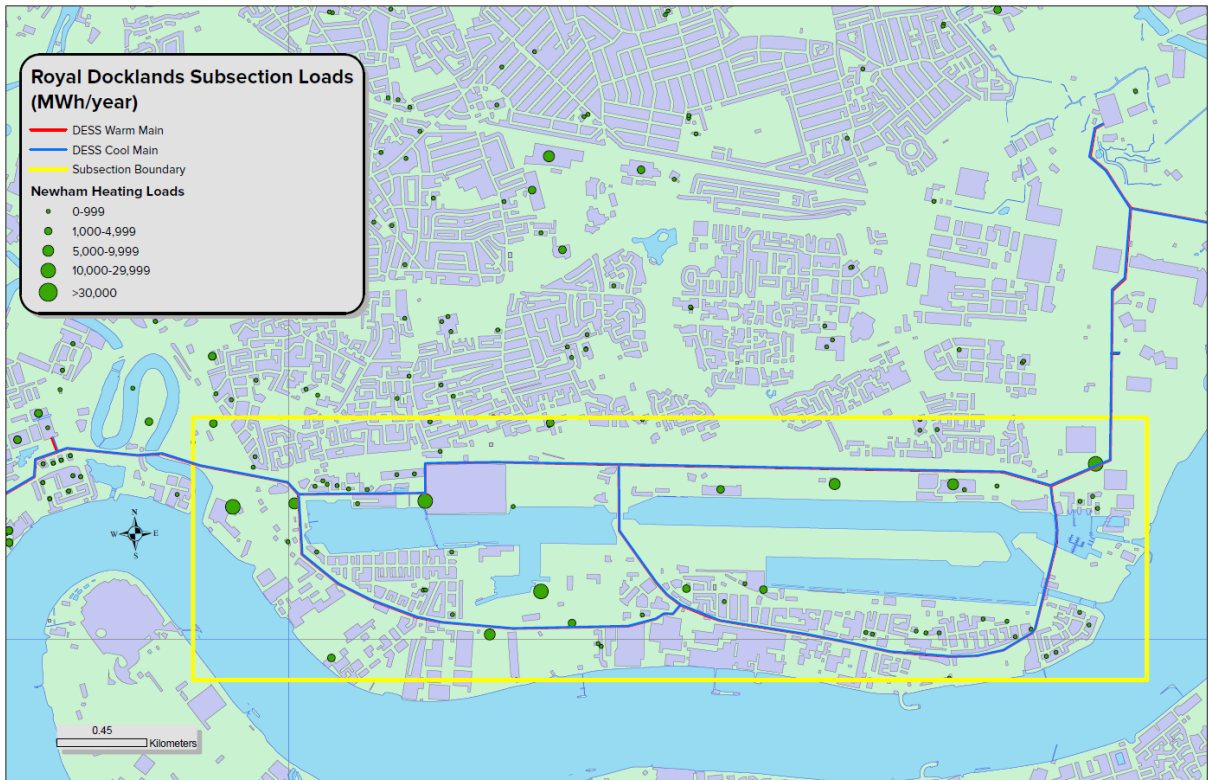

APPENDIX H – DESS Concept Schematic

LONDON DECENTRALIZED ENERGY STUDY SAMPLE DESS CONNECTIONS

