



CHARLTON
RIVERSIDE
P H A S E O N E

ENVIRONMENTAL STATEMENT ADDENDUM
VOLUME IIIA: TECHNICAL APPENDICES

Rockwell

APPENDIX 6.1A

Pupil Forecast and Net Capacity Data

Planning Areas

Underlying Forecast Data				Actuals 2016/17													Forecast Year 2017/18														
LA Number	LA Name	Planning Area Code	Planning Area Name	R	1	2	3	4	5	6	7	8	9	10	11	12	13	R	1	2	3	4	5	6	7	8	9	10	11	12	13
203	Greenwich	2031001	School Place Planning Area 1 Primary	1,027	1,021	1,020	993	1,010	926	807								970	927	931	920	911	925	931							
203	Greenwich	2031002	School Place Planning Area 2 Primary	517	515	469	443	434	382	362								570	541	562	497	444	435	380							
203	Greenwich	2031003	School Place Planning Area 3 Primary	589	578	548	522	505	519	506								660	651	615	602	599	589	522							
203	Greenwich	2031004	School Place Planning Area 4 Primary	457	487	459	431	479	423	428								465	472	491	456	434	474	430							
203	Greenwich	2031005	School Place Planning Area 5 Primary	429	438	439	427	441	424	425								445	432	436	434	428	440	422							
203	Greenwich	2031006	School Place Planning Area 6 Primary	662	654	638	583	590	592	597								650	657	651	634	575	586	591							
203	Greenwich	2031007	Borough-wide Secondary								2,739	2,473	2,407	2,292	2,181	1,412	979								2,890	2,742	2,501	2,437	2,268	1,445	1,002

Underlying Forecast Data				Forecast Year 2018/19													Forecast 2019/20														
LA Number	LA Name	Planning Area Code	Planning Area Name	R	1	2	3	4	5	6	7	8	9	10	11	12	13	R	1	2	3	4	5	6	7	8	9	10	11	12	13
203	Greenwich	2031001	School Place Planning Area 1 Primary	960	956	926	914	919	909	930								940	946	955	909	913	917	914							
203	Greenwich	2031002	School Place Planning Area 2 Primary	600	572	538	561	498	446	432								655	602	569	537	562	500	443							
203	Greenwich	2031003	School Place Planning Area 3 Primary	660	663	644	614	600	599	592								660	663	656	643	612	600	602							
203	Greenwich	2031004	School Place Planning Area 4 Primary	465	483	475	486	459	429	480								475	483	486	470	489	454	435							
203	Greenwich	2031005	School Place Planning Area 5 Primary	445	449	430	432	433	427	438								445	449	447	426	431	432	425							
203	Greenwich	2031006	School Place Planning Area 6 Primary	650	648	651	647	626	572	584								670	648	642	647	639	623	570							
203	Greenwich	2031007	Borough-wide Secondary								3,100	2,897	2,767	2,536	2,411	1,416	981								3,300	3,107	2,922	2,802	2,510	1,418	983

Underlying Forecast Data				Forecast 2020/21													Forecast 2021/22														
LA Number	LA Name	Planning Area Code	Planning Area Name	R	1	2	3	4	5	6	7	8	9	10	11	12	13	R	1	2	3	4	5	6	7	8	9	10	11	12	13
203	Greenwich	2031001	School Place Planning Area 1 Primary	950	926	945	938	908	911	922								950	936	925	928	937	906	916							
203	Greenwich	2031002	School Place Planning Area 2 Primary	690	657	599	568	538	564	497								720	692	654	598	569	540	561							
203	Greenwich	2031003	School Place Planning Area 3 Primary	670	663	656	655	641	612	603								680	673	656	655	653	641	615							
203	Greenwich	2031004	School Place Planning Area 4 Primary	480	493	486	481	473	484	460								490	498	496	481	484	468	490							
203	Greenwich	2031005	School Place Planning Area 5 Primary	445	449	447	443	425	430	430								445	449	447	443	442	424	428							
203	Greenwich	2031006	School Place Planning Area 6 Primary	680	668	642	638	639	636	621								685	678	662	638	630	636	634							
203	Greenwich	2031007	Borough-wide Secondary								3,320	3,307	3,132	2,957	2,776	1,460	1,013								3,490	3,327	3,332	3,167	2,931	1,546	1,072

Underlying Forecast Data				Forecast 2022/23													Forecast 2023/24														
LA Number	LA Name	Planning Area Code	Planning Area Name	R	1	2	3	4	5	6	7	8	9	10	11	12	13	R	1	2	3	4	5	6	7	8	9	10	11	12	13
203	Greenwich	2031001	School Place Planning Area 1 Primary																												
203	Greenwich	2031002	School Place Planning Area 2 Primary																												
203	Greenwich	2031003	School Place Planning Area 3 Primary																												
203	Greenwich	2031004	School Place Planning Area 4 Primary																												
203	Greenwich	2031005	School Place Planning Area 5 Primary																												
203	Greenwich	2031006	School Place Planning Area 6 Primary																												
203	Greenwich	2031007	Borough-wide Secondary								3,570	3,497	3,352	3,367	3,141	1,644	1,140								3,600	3,577	3,522	3,387	3,341	1,710	1,186

*Figures based on the latest available data (2016/17) published in 2018

Forecast

Primary Schools											
LA Number	LA Name	Planning Area Code	Planning Area Name	Actuals 2016/17	Forecast Year 2017/18	Forecast Year 2018/19	Forecast Year 2019/20	Forecast Year 2020/21	Forecast Year 2021/22	Forecast Year 2022/23	Forecast Year 2023/24
Greenwich											
203	Greenwich	2031001	School Place Planning Area 1 Primary	6,804	6,515	6,514	6,494	6,500	6,498	6,439	6,381
			Percentage Change	-	-4.25	-0.02	-0.31	0.09	-0.03	-0.90	-0.90
203	Greenwich		School Place Planning Area 1 Primary Capacity	7,613	7,613	7,613	7,613	7,613	7,613	7,613	7,613
			School Place Planning Area 1 Net Capacity	809	1,098	1,099	1,119	1,113	1,115	1,174	1,232
203	Greenwich	2031002	School Place Planning Area 2 Primary	3,122	3,429	3,647	3,868	4,113	4,334	4,628	4,943
			Percentage Change	-	9.83	6.36	6.06	6.33	5.37	6.79	6.79
203	Greenwich		School Place Planning Area 2 Primary Capacity	3,529	3,529	3,529	3,529	3,529	3,529	3,529	3,529
			School Place Planning Area 2 Net Capacity	407	100	-118	-339	-584	-805	-1,099	-1,414
203	Greenwich	2031003	School Place Planning Area 3 Primary	3,767	4,238	4,372	4,436	4,500	4,573	4,758	4,950
			Percentage Change	-	12.50	3.16	1.46	1.44	1.62	4.04	4.04
203	Greenwich		School Place Planning Area 3 Primary Capacity	4,141	4,141	4,141	4,141	4,141	4,141	4,141	4,141
			School Place Planning Area 3 Net Capacity	374	-97	-231	-295	-359	-432	-617	-809
203	Greenwich	2031004	School Place Planning Area 4 Primary	3,164	3,222	3,277	3,292	3,357	3,407	3,458	3,509
			Percentage Change	-	1.83	1.71	0.46	1.97	1.49	1.49	1.49
203	Greenwich		School Place Planning Area 4 Primary Capacity	3,489	3,489	3,489	3,489	3,489	3,489	3,489	3,489
			School Place Planning Area 4 Net Capacity	325	267	212	197	132	82	31	-20
203	Greenwich	2031005	School Place Planning Area 5 Primary	3,023	3,037	3,054	3,055	3,069	3,078	3,089	3,100
			Percentage Change	-	0.46	0.56	0.03	0.46	0.29	0.36	0.36
203	Greenwich		School Place Planning Area 5 Primary Capacity	3,090	3,090	3,090	3,090	3,090	3,090	3,090	3,090
			School Place Planning Area 5 Net Capacity	67	53	36	35	21	12	1	-10
203	Greenwich	2031006	School Place Planning Area 6 Primary	4,316	4,344	4,378	4,439	4,524	4,563	4,614	4,666
			Percentage Change	-	0.65	0.78	1.39	1.91	0.86	1.12	1.12
203	Greenwich		School Place Planning Area 6 Primary Capacity	4,505	4,505	4,505	4,505	4,505	4,505	4,505	4,505
			School Place Planning Area 6 Net Capacity	189	161	127	66	-19	-58	-109	-161
			All Primary	24,196	24,785	25,242	25,584	26,063	26,453	26,987	27,549
			All Primary Capacity	26,367	26,367	26,367	26,367	26,367	26,367	26,367	26,367
			Percentage Change	-	1.98	1.63	1.67	0.76	1.35	1.48	1.48
			Net Capacity	2,171	1,582	1,125	783	304	-86	-620	-1,182
Secondary Schools											
LA Number	LA Name	Planning Area Code	Planning Area Name	Actuals 2016/17	Forecast Year 2017/18	Forecast Year 2018/19	Forecast Year 2019/20	Forecast Year 2020/21	Forecast Year 2021/22	Forecast Year 2022/23	Forecast Year 2023/24
Greenwich											
203	Greenwich	2031007	Borough-wide Secondary	14,483	15,285	16,108	17,042	17,965	18,865	19,711	20,323
			Borough-wide Secondary Capacity	17,957	17,957	17,957	17,957	17,957	17,957	17,957	17,957
			Percentage Change	-	5.54	5.38	5.80	5.42	5.01	4.48	3.10
			Net Capacity	3,474	2,672	1,849	915	-8	-908	-1,754	-2,366

*Figures based on the latest available data (2016/17) published in 2018

APPENDIX 7.1A

Transport Assessment Addendum (TAA)

**Leopard Gurnsey Anchor
Propco Ltd**
Anchor and Hope Lane Sites
Charlton Riverside
Transport Assessment
Addendum

November 2018

Contents

1 Introduction.....1

2 Statutory Consultees’ Comments.....3

3 Proposed Amendments to the Scheme4

4 Trip Generation and Transport Impacts9

5 Cumulative Impacts 11

6 Summary and Conclusion 13

Figure 1.1 – Site Location Plan

Appendix A – Responses to Consultees’ Comments

Appendix B –Drawings

1 INTRODUCTION

1.1 General

1.1.1 Transport Planning Practice (TPP) has been appointed to prepare a Transport Assessment Addendum for the proposed redevelopment of the VIP Trading Estate and VIP Industrial Estate (also known as the Anchor and Hope Lane sites). The site consists of two plots and is located within the Charlton Riverside Opportunity Area in the Royal Borough of Greenwich (RBG). Figure 1.1 shows the location of the site.

Figure 1.1 – Site Location Plan

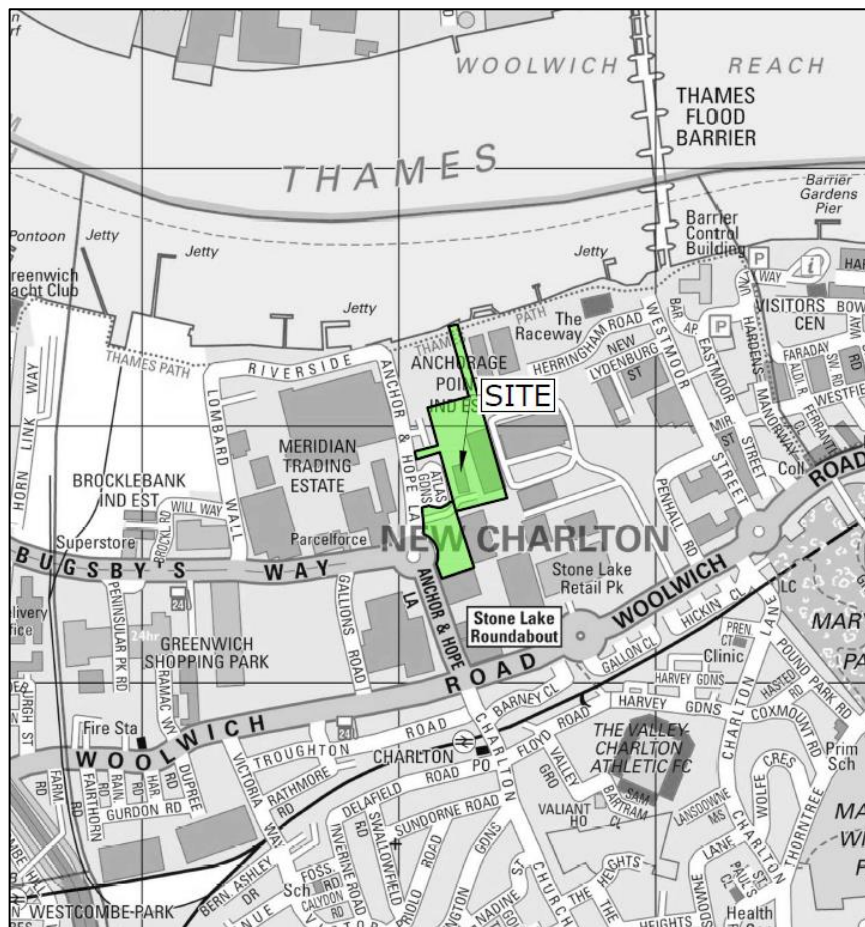

1.2 Background and context

- 1.2.1 In December 2016, a planning application was submitted for the site (planning reference 16/4008/F) to provide 975 units residential as well as commercial space (A1, A3, B1, D1 and D2 use classes).
- 1.2.2 Following consultation on the submission, a number of design changes were made to the planning application, resulting in the reduction in the number of

residential units to 771 and a reduction to the commercial floor-space. The application was amended in December 2017 accompanied by a Transport Assessment (TA), prepared by TPP, and an Environmental Statement. The application was subsequently refused by RBG at a planning committee in July 2018 on grounds not related to transport, other than providing continued access to the adjacent business premises at Imex House. In August 2018, the Mayor of London called in RBG's decision to reject the scheme and has taken over the determination of the planning application. As part of this process, feedback on the scheme has been received from the Greater London Authority (GLA) resulting in further amendments to the design of the scheme. In relation to transport considerations this has resulted in the access to the basement car park for Plot A being amended and the level of cycle parking increased.

- 1.2.3 This Transport Assessment Addendum outlines the alterations that have been made and sets out how these affect the trip generation and the impact assessment of the amended scheme against the 2017 submission.

2 STATUTORY CONSULTEES' COMMENTS

2.1.1 Following the December 2017 submission, a series of comments were made by the statutory consultees. These include comments from RBG Highways, RBG Waste and Street services, the Port of London Authority (PLA), the GLA and TfL. All relevant comments have been responded to by TPP including provision of clarification and additional information where it was necessary to address a particular comment. The comments and TPP responses are provided in Appendix A which includes:

- **TPP Note (ref D25) February 2018** responding to comments from RBG Highways, Waste and Street Services and the PLA.
- **An extract of the GVA tracker** setting out responses to comments related to transport made by Transport for London (TfL) and RBG Waste and Street Services.

2.1.2 It should be noted that none of the consultation comments resulted in any fundamental design alterations or amendment to the assessment of the transport impact of the development proposals. Therefore, the assessment methodology remains valid and has been continued for the Transport Assessment Addendum.

3 PROPOSED AMENDMENTS TO THE SCHEME

3.1 Introduction

3.1.1 The amended scheme includes reduction in height at Buildings G and J and provision of additional floors to Buildings D, E and F. This has not altered the overall number of apartments within the site. The total number of residential units remains unchanged at 771.

3.1.2 There are slight changes being made to the commercial floorspace resulting in an overall increase of 44m² GIA compared to the December 2017 submission, however, this is now split between A-class and B-class commercial uses. Additionally, the ancillary residential facilities included in the December 2017 scheme have been amended to D2 community use with no alteration to the overall GIA. A small 1m² increase in the D1 community use has also resulted from the proposals.

3.1.3 A summary of the amendments to the scheme is provided in Table 2.1.

Table 2.1 - Summary of Amendments to Proposed Development

Land Use	December 2017 Submission	Proposed Development 2018	Overall Difference
Residential (No of units)			
C3 Residential	771	771	0
Ancillary Residential (GIA m²)			
Ancillary facilities	496	0	-496
Non-residential (GIA m²)			
D2 – Community Use	0	496	+496
Community Use (D1 crèche)	337	338	+1
Flexible Commercial Floorspace A1- A5/B1/D1/D2	3,236	B1: 3,097 A1-A5: 183 Total 3,280	+44

3.2 Access

3.2.1 The overall access arrangements to the proposed development remain as per the 2017 submission. It is proposed to relocate entrance to basement car park for Plot A from underneath Block F to underneath Block A. This alteration is wholly within the site roads within the site boundary and does not impact on the surrounding network. As previously, the car park will be accessed by a two-way vehicle ramp with a gradient of 1:10. Drawings 30821/AC/232 and Drawing

30821/AC233 in Appendix B show a swept path analysis of a car accessing the basement car park at Plot A and Plot B, respectively.

3.2.2 The extent of the highways works on the public highway remains unchanged and this is shown in Drawing 30821/AC/216_C included in Appendix B in the context of the amended scheme.

3.3 Car Parking

3.3.1 The car parking provision proposed for the development at the site includes a total of 208 spaces. Of these 207 will remain for the residential use and 56 (27%) of these will be accessible bays suitable for Blue Badge holders. In addition, 43 spaces (21%) will be provided at the outset with EV charging facilities.

3.3.2 In addition, there are a further 14 spaces provided at ground level on the eastern side of Plot B. These car spaces currently exist in this location and will continue to be used.

3.4 Cycle Parking

3.4.1 Cycle parking at the proposed development will be provided in accordance with the Draft New London Plan (2018) standards. A summary of the cycle numbers for the amended scheme is set out in Table 3.1 and Table 3.2, for the residential and commercial elements of the scheme respectively.

Table 3.1 – Minimum Residential Cycle Parking Provision

Residential unit	Minimum cycle parking standards	Proposed units	Minimum requirement cycle parking
Studio	1 space	144	144
1 Bedroom	1.5 spaces	202	304
2 or More Bedrooms	2 spaces	425	850
Visitor Spaces	1 per 40 apartments	771	20
Total spaces to be provided		-	1,298 Long Stay 20 Short Stay

Table 3.2 – Minimum Non-Residential Cycle Parking Provision

Land Use	Proposed floor area (m ² GEA)	Long stay cycle parking	Short stay cycle parking
Flexible commercial use	B1: 3,250m ²	44	7
	A1-A5: 201m ²	3	11
D1 crèche	373m ² (16 staff + 56 pupils)	9 (2 adult, 7 children)	1
D2 Community Space	536m ² (8 staff)	1	6
Minimum number of cycle parking spaces to be provided		57	25

3.4.2 Long Stay cycle parking is provided within secure cycle stores within each plot. Full account has been taken of the requirements and guidance within the London Cycle Design Standards. 5% or more are provided for larger bikes in Sheffield stands and the remainder provided in two-tier cycle racks. Short stay cycle parking spaces are provided in the public realm in Sheffield stands located at suitable positions.

3.5 Servicing and refuse collection

3.5.1 The servicing arrangements for the proposed development including refuse collection are unchanged. All swept path analysis drawings related to servicing and refuse collection have been updated in the context of the amended scheme and these are provided in Appendix B including:

- Drawing 30821/AC/209_C - Plot A: Swept path analysis of a 10m rigid vehicle.
- Drawing 30821/AC/210_C - Plot B: Swept path analysis of a 10m rigid vehicle.
- Drawing 30821/AC/234 - Plot A: Swept path analysis of a 3.5 tonne LGV.
- Drawing 30821/AC/235 - Plot B: Swept path analysis of a 3.5 tonne LGV.
- Drawing 30821/AC/211_C - Plot A: Swept path analysis of a 10.2m refuse vehicle.
- Drawing 30821/AC/212_C - Plot B: Swept path analysis of a 10.2m refuse vehicle.

3.6 East-West Link

3.6.1 The proposed future East-West Link Road in the context of the amended scheme is provided in Drawing 30821/AC/228_A in Appendix B.

3.6.2 The delivery of the East West Link Road forms part of the wider Charlton Riverside SPD, as such the details of this road and its function are set out in this document. A summary of the key parameters for the road are as follows:

- The width of the route corridor is defined to be 24m to 27.5m.
- It provides a primary movement corridor, along which public transport might run, from Anchor and Hope Lane to Warspite Road/Woolwich Road Junction.
- The route will be designed to facilitate future bus services.
- It is not intended to provide an alternative route for strategic traffic, which will remain on the A206 Woolwich Road.
- Access will be restricted to local journeys and access, public transport, cyclists and emergency vehicles; via a mechanism such as a bus gate at the eastern end of the new link.
- Where possible the route will use existing roads and routes, but it will be necessary for some sections to run along the edges of development parcels.

3.6.3 In terms of its alignment, through the proposed development, the corridor has been safeguarded to enable its future delivery through the master plan area within the design of the site.

3.7 Provision of Access to Imex House

3.7.1 The amended development continues to take account of the requirements for the right of access to Imex House and incorporates it as an internal access route for servicing of Building D, E, F, G and H and refuse collection for Building G and H. No car parking is provided within this access road and access will be managed and controlled to ensure that the route is unobstructed.

3.7.2 From discussion with the occupier of Imex House it is understood that they have a Winnebago 'Tour Bus' which is typically parked in the southwest corner of their

land, although the occupier has also said that it can park in the eastern side of their building. Further discussion with the occupier also highlighted that a longer 13.1m coach is sometimes used by them. The vehicle could either park or simply turn and drop-off/pick-up.

- 3.7.3 The proposed scheme layout and landscape plan has always been designed to accommodate vehicle access to Imex House to either location where the occupier's Tour Bus may be parked. Drawings 30821/AC/213_C and Drawing 30821/AC/231_A show the vehicle swept paths for the Tour Bus (Winnebago) and a 13.1m long coach respectively turning and manoeuvring outside Imex House.

3.8 Safeguarded Wharves

- 3.8.1 The site's proximity to St Angerstein Wharf, Murphy's Wharf and Riverside Wharf in relation to the proposed development was fully acknowledged as part of the 2017 submission. As part of the amended scheme, there continues to be no proposed changes to any roads where access is provided to the safeguarded wharves. On this basis, highway access to safeguarded wharves and barge work will be maintained without any disruption either during construction or when operational. In addition, the proposed development is not expected to have any material traffic impact on the roads providing access to the safeguarded wharves.

4 TRIP GENERATION AND TRANSPORT IMPACTS

4.1 Trip Generation

Residential

- 4.1.1 The proposed number of residential units remains unchanged and therefore there is no impact on the trip generation assessment undertaken for the December 2017 submission which remains valid for the amended scheme. Similarly, there are no changes to the servicing vehicle generation.

Non-residential uses

- 4.1.2 With regard to commercial space, this has become more defined than assessed in the December 2017 ES where it was described as 'flexible'. Thus, in order to undertake a robust assessment, the highest likely trip generating land use (B1 office) was assumed for all of the area proposed. As a result of the revisions and refinements to the scheme the area proposed as B1 office use has reduced and generally replaced with a small flexible retail (A1-A5) area which is intended to be ancillary to the amended proposed development, providing amenity for the future occupants, and therefore attracting primarily internal trips. Therefore, a worse case assessment, in terms of peak hour trip generation, was undertaken within the December 2017 Transport Assessment (TA). Therefore, the original trip generation in the 2017 TA remains a suitable and robust assessment of the commercial space generated trips for the proposed amended scheme.
- 4.1.3 The very small increase in community use of 1m² of D1 space would not have any impact on trips, as this was based on staff and pupil numbers for the crèche/nursery use. In addition the alteration from C3 ancillary residential amenity space to D2 community space would not impact on any of the trip generation figures as staff levels would be similar and expected to be arranged in shift work, arriving and leaving outside of the peak hours. Therefore, this use has been excluded from the trip generation assessment.
- 4.1.4 In summary, the original trip generation assessment continues to be valid for the amended scheme.

4.2 Impact Assessment

- 4.2.1 The submitted December 2017 TA included a detailed assessment of the impact of the proposed development trips on each of the different transport modes. From this assessment it was concluded that the proposed development is not expected to have any significant impact on the surrounding transport network.
- 4.2.2 Given that there is no change to the residential or commercial trip generation analysis which formed the basis of the 2017 impact assessment, it is concluded that the December 2017 TA provides a valid assessment of the current scheme and can be wholly relied on to be relevant for assessing the proposed development.

5 CUMULATIVE IMPACTS

- 5.1.1 The December 2017 TA provided a cumulative impact assessment on the local transport network taking account of the committed developments and the proposed scheme.
- 5.1.2 Since the December 2017 submission five additional applications have been identified. It is noted that three of these are reserved matter applications associated with schemes already taken into account. Details of the two new committed development schemes are as follows:
- Victoria Way (17/1795/F40); and
 - Herringham Road (Komoto) (18/0732/F).
- 5.1.3 For both schemes, a review of their planning application documents has been undertaken and account taken of their transport impacts in this assessment.
- 5.1.4 Both schemes are expected to have an impact on Woolwich Road (A206). As a result, the updated cumulative baseline flows are shown in Table 5.1. The comparable Table in the December 2017 TA is Table 20.5 for ease of reference. From Table 5.1 below, it can be seen that the impact of the proposed development traffic on the new cumulative baseline remains unchanged from that included in the December 2017 TA, for both the AM and the PM peak hour. Thus the assessment and conclusions reached in respect of the traffic impact of the proposed development within the December 2017 remain valid.

Table 5.1– Cumulative Baseline and Proposed Development Traffic Flows

Link	Cumulative Baseline flows		Cumulative Baseline + Proposed Development		Percentage Difference		Comparison to 2017 Assessment	
	AM Peak	PM Peak	AM Peak	PM Peak	AM Peak	PM Peak	AM Peak	PM Peak
Anchor & Hope Lane North of Bugsby's Way	251	249	338	303	35%	22%	0%	0%
Anchor & Hope Lane North of Site Access	192	135	185	134	-4%	-1%	0%	0%
Anchor & Hope Lane South of Bugsby's Way	1,385	1,710	1,423	1,743	3%	2%	0%	0%
Bugsby's Way West of Gallions Road	1,426	1,841	1,476	1,860	4%	1%	0%	0%
Bugsby's Way East of Gallions Road	1,461	2,136	1,512	2,159	4%	1%	0%	0%
Charlton Church Lane North of Delafield Way	418	468	423	476	1%	2%	0%	0%
A206 East of Anchor & Hope Lane	2,288	2,767	2,335	2,786	2%	1%	0%	0%
A206 West of Anchor & Hope Lane	1,337	1,323	1,338	1,326	0%	0%	0%	0%
Site Access (Private Road)	107	120	187	172	75%	44%	0%	0%
Gallions Road	202	390	200	393	-1%	1%	0%	0%

6 SUMMARY AND CONCLUSION

- 6.1.1 This Transport Assessment Addendum has been prepared in support of amendments to the proposed redevelopment of the VIP Trading Estate and VIP Industrial Estate (also known as the Anchor and Hope Lane sites) within the Charlton Riverside Opportunity Area in the Royal Borough of Greenwich (RBG).
- 6.1.2 The proposed amendments currently proposed are in response to feedback received from the GLA following the Mayor's decision to take over the determination of the application after it was refused by RBG (planning reference 16/4008/F).
- 6.1.3 It has been demonstrated that the proposed amendments do not have any impact on the trip generation and the impact assessment undertaken as part of the December 2017 submission given that there is no change in the number of residential units and the change in non-residential uses and floorspace is such that the December 2017 TA trip generation represents a robust assessment for these elements of the amended scheme.
- 6.1.4 Vehicle swept path analysis drawings have been updated to illustrate vehicle manoeuvres in the context of the amended scheme. A plan showing the future East-West link corridor has also been provided which is in line with the aspirations of the RBG's Masterplan for the wider area.
- 6.1.5 Cycle parking provision at the development will meet the Draft New London Plan (2018) for all elements of the proposed scheme.
- 6.1.6 The proposed scheme will continue to have no impact on the operations of the nearby safeguarded wharves and access rights to Imex House will continue to be retained.
- 6.1.7 Since the 2017 submission, additional committed developments have been identified and considered. The updated cumulative assessment demonstrates that these do not materially affect the results of the original assessment.
- 6.1.8 In summary, the conclusions of the December 2017 Transport Assessment remain valid for the amended scheme.

- 6.1.9 In conclusion, the proposed scheme will deliver a high quality development which will be accessible by walking, cycling, buses and rail. The development benefits from its location for encouraging sustainable transport choices.
- 6.1.10 The scheme has been designed to accommodate for the expected level of walking and cycling trips and the generated trips by each of the different modes of transport can be accommodated on the surrounding transport infrastructure.
- 6.1.11 Finally, the proposed development fully meets the transport aspirations of the Royal Borough of Greenwich and current Governmental guidance in respect of sustainable development and will, through its design, encourage the use of sustainable modes of transport.

Appendix A
Responses to
Consultees' Comments

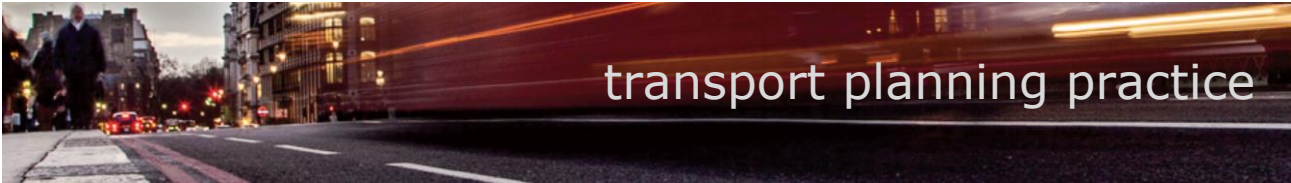

Charlton Riverside Ref: 16/408/F

Anchor and Hope Lane Sites

Response to Consultee Comments

Introduction

1. This note has been prepared to address a further series of transport comments made by the statutory consultees following the submission of the planning application for the Anchor and Hope Lane site, Charlton, (planning reference 16/4008/F). These include comments from the Royal Borough of Greenwich (RBG) Waste and Street Services and the Port of London Authority (PLA). These responses have been reviewed, and this note sets out our response to the issues raised.

Response to RBG Comments on Master Plan Road Infrastructure

2. RBG have requested that it should be demonstrated that the East-West route through between the two plots (a 20m road corridor) can be delivered at a later stage when the wider Charlton Riverside masterplan is implemented.

Response:

3. The development proposals for the site have always been cognisant of the wider Charlton Riverside Masterplan and have been developed around a general framework of highway infrastructure. As neither RBG nor their appointed masterplan team have prepared a sufficiently detailed drawing the applicant has prepared such a plan to enable the preparation of development schemes on their plots. TPP Drawing Numbered 30821/AC/217 indicates the provision of a 20m highway corridor in the vicinity of the application site.

Response to RBG Waste Officer comments

4. Comments on the waste storage and provision have been made by the RBG Assistant Strategy Manager. These comments are noted and where there may have been omissions they are being taken on board. A response to the comments made are set out below.

Refuse and recycling container quantities

The numbers of refuse and recycling containers proposed in each core consistently falls between 3 and 5 containers below that which we require (based upon the metric in our waste guidance notes in new developers). I have calculated the required number of containers in the table pasted below. We would require the bin quantities to meet these as closely as possible. Please note that I have made an assumption that the two bin stores in Block H equally serve 31 of the 62 total properties due to the equal number of bins shown – if that's not the case then the model may require some adjustment.

5. When developing the proposals, the RGB waste guidelines were used to calculate volumes along with a comparison with those provided by the Building Regulations Part H6 and also the British Standards BS 5906. It is noted that RGB's waste guidelines result in a higher generation of waste than either of these national standards and guidance. The following brief summary sets out how much higher these figures are:

RGB Guidance is 90% higher than (BS5906+25%)

RGB Guidance is 26% higher than Building Regulations Part H6

6. In respect of the BS 5906(+25%) the reason for the huge discrepancy is the fact that the average number of bedrooms per residential unit across the scheme is 1.7 bedrooms per dwelling. In such cases, it would be more appropriate to use the BS 5906(+25%) calculation. Therefore the tabulated 'deficiency' calculated by RGB would still meet the Building Regulations H6 levels and exceed the BS5906(+25%) requirements.
7. In respect of the provisions for Textiles, WEEE and batteries, the scheme will provide a centralised bin within each plot for each of these waste streams, rather than the local bin stores, close to the bulk waste store area for each plot. Therefore the local waste stores will each provide sufficient 1100L Eurobins for both General and Mixed Dry Recyclable (MDR) Waste based on RGB's guidance, along with 240L wheeled bins for Organic Waste.
8. In respect of the split in Block H, H North has 29 units and H South has 33 units. Thus H South will be provided with a greater number of bins.
9. The Local Bin Stores are being rearranged in accordance with the above.

Basement Bin Storage

We have no issue in theory with bin stores being at basement level for resident use and the bins being moved to a ground floor collection point for weekly collection. For this to work properly the bin holding areas will need to be large enough to accommodate the entirety of one waste stream for the properties it serves. For example the Plot A holding area shows 20 spaces, however there are 45 mixed dry recycling containers in the bin stores of blocks A-F so this will need to be increased.

10. For collection of residential waste by RGB the combination of the ground floor collection room and the basement bin holding area will be used for the waste streams being collected. One minor note in respect of Plot A is that with the close proximity of the local bin store for Building B, there would not be a need to move the waste to the holding area for collection, as it is adjacent to the waste lift. On-site management would be in attendance during the waste collection times with staff within both the basement bin holding area and the waste collection room to transfer bins using the bin lift. Therefore the RGB waste operatives will only need to move the bins from the ground level collection rooms to their vehicle, with all other bin movements internally undertaken by on-site staff.

Where lifts are proposed to move the bins up to ground floor left I recommend two lifts at each point to ensure cover breakdowns and ensure there are no missed collections. RGB will not re-attend the development if the containers are no presented for collection due to faults with the lifts.

11. Lift failures for industrial type lifts are uncommon and therefore the need for duplication is unnecessary. In the event that there is a mechanical failure, the bins would be brought

up to ground level by on-site staff using the bin tugs that will be used to transfer the bins between the local bin stores and the Holding and Collection waste stores.

It is not shown how many bins can be accommodated in the lift, however there will be a limited capacity therefore the onsite staff may find the process onerous.

12. The lifts will be sized to accommodate 2 eurobins simultaneously with on-site staff at both basement and ground floor levels.

What are the distances between the bin stores and the lifts? On site staff may require towing equipment to make these manoeuvres. If the distances are great it may be considered unsafe for the staff to carry this out by hand.

13. On-site staff will use manual towing tugs which have a towing capacity of up to 4 tonnes, therefore multiple bins can be moved at a time.

It is not obvious where the bulky waste stores mentioned in the design and access statement are located in the basements of plots A and B.

14. The Bulk Waste Store for Plot A is adjacent to the basement bin holding area. For plot B, a Bulk Waste Store will be included.

The commercial units will each contain their own refuse store separate from those of the residential units. These are not currently shown.

15. The commercial units will, within the fit out of their demise, include their own waste storage provisions. These are not currently shown as the commercial space is subject to a flexible set of land uses and as a result the waste generations can be quite different between operators. Commercial units are currently shown as a 'shell' which will be leased. The responsibility of the future tenant will be to include waste storage within their own demise.

General collections observations

It is stated in the design and access statement that "The refuse collections will be made early in the morning and the management team will ensure the bins are brought to the service bay prior to the refuse vehicle's arrival" RBG cannot guarantee early morning collections due to a number of uncertainties such as adverse weather, vehicle breakdowns or unusual traffic.

16. Typically that would be what would be expected, however, it is noted that collections may be undertaken at different times although generally there would be expected to be a regular time that collections would occur, whilst appreciating that there would be some flexibility in the event of RBG fleet or weather difficulties.

The bin stores of Blocks G and H are detailed as being on a 'Play street'. What does this mean?

17. There are very few vehicle movements within the 'play street' which serves buildings G and H. The street is a cul-de-sac and provides access to Imex House at the northern end, servicing and waste collections for buildings G and H. This equates to 1 or 2 vehicle movements per hour, well below the homezone type of classification, and is therefore provided as public realm in which vehicles have access.

What are the distances of the 'bin wheeling routes' shown for blocks G and H? It should be noted that RBG operatives should not be required to drag bins for more than 15m to the waiting collection vehicle.

18. Wheeling routes, with suitable hard surfacing, will be provided through the landscaped public realm directly outside the waste storage rooms within Buildings G and H which meet the 15m drag distances.

Vehicle access considerations

The vehicle tracking in the two locations below appears to show obstruction with the building. If the building overhangs the road then adequate clearance needs to be allowed for the vehicle and extra height required to operate the lifting mechanism. In both instances it appears the vehicle may need to mount the kerb to turn, this would not be acceptable.

19. The building outlines referred to are the upper levels of the buildings. The ground levels within the vehicle tracking are clear of physical obstructions, and are within a flat shared surface, thus there are no kerbs mounted. Headroom clearance is provided in excess of 3.8m.

Can it be confirmed that in the locations where the refuse collection vehicles are proposed to stop that other vehicles can safely pass.

20. The locations where the waste lorry is stopped, the route is 5.5m wide or greater this will enable other vehicle to pass. However, the number of other vehicle movements is very small and will be managed.

Response to PLA comments

21. Transport comments were made by PLA in their email dated 02 February 2018. The quotes in italics are directly taken from the PLA email.

Issue: Impact of construction traffic on the safeguarded wharves:

'Whilst it is accepted that residential use in itself is unlikely to impede on the operations of the vehicles associated with the Wharves, it is surprising that no consideration has been given to construction traffic associated with the proposed development at construction stage, as these are far more likely to cause a problem in terms of access to the Wharves.'

Response:

22. There are no proposed changes to any roads where access is provided to the safeguarded wharves during the construction stage and therefore there will be no impact on the access arrangements to the wharves during construction.
23. The impact of construction traffic on the local roads network was assessed within the Transport Assessment (Chapter 20). It is noted that the existing site currently generates vehicle movements associated with its industrial uses which will cease prior to the construction of the scheme. The assessment showed that the number vehicles associated with the construction activities would be less than the traffic already generated by the existing site. Accordingly, all key roads would experience a reduction in overall traffic during the construction stage and would not cause a negative impact in terms of access to the Wharves. This is the reason why no further consideration was necessary of the construction stage of the proposed development in terms of traffic impact on the

safeguarded wharves operation, as there would be an improvement. The PLA could have come to the same conclusion, had they made this comparison.

Issue: Consideration of level of services and connection to infrastructure to accommodate further residential units:

'Not only this, but the level of services and connection to infrastructure (which is required to accommodate further residential units in the area) has also been missed, and should be considered as a possible negative impact. Angerstein and Murphy's Wharves are active for aggregate and bulk operations, which rely heavily on the Thames. The Wharves are safeguarded by Ministerial Direction and Policy 7.26 of the London Plan, which protect the Wharves for cargo handling. The proposed development must not restrict the operations of the Wharves, and retain good access onto the local road network.'

Response:

24. The Transport Assessment included a detailed impact assessment of the proposed development on the local transport infrastructure including junction modelling work. It was concluded that the transport demand arising from the additional units can be met by the existing services. Additionally, the public realm proposals within the scheme will improve the quality of connections across the site to the existing links and eventually the wider masterplan. If anything this constitutes an improvement rather than a 'possible negative impact'.
25. Finally, the proposed development does not propose any changes to any roads that provide access to the wharves and would not restrict their operations or affect their ability to access the local road network, nor does it propose any alteration to the movement of boats along the Thames. Therefore the operations of the wharves will remain unchanged.

Issue: Consideration to alternative modes of transport for the delivery of goods and removal of waste associated with the construction

'The ES provides limited consideration to alternative modes of transport for the delivery of goods and removal of waste associated with the construction. It is recognised within the supporting documentation that there are local concrete batching plants at Angerstein Wharf (Cemex) on Bugsbys Way and Victoria Deep Water Terminal (Hanson) at Tunnel Avenue that are both within 3km of the site, and which are both served by the River. The Applicant has stated that both of these would be considered by the main contractor and if used, would reduce the travel distances by road for the provision of concrete and aggregates. However, it is stated within the submission that for a robust assessment of the impact of the demolition and construction works on the highway network, it is assumed in the ES that these materials will be transported by road. I am not sure I completely agree with the reasoning provided and the PLA remain disappointed that serious consideration of the possibility of using the River Thames (waterborne freight) has not been given. Policy guidelines encourage Local Authorities to promote sustainable development in their planning decisions. As road freight is a major contributor to CO2 and to congestion, waterways should be considered as part of the solution to reduce dependency on road haulage. Paragraphs 29 and 30 of the National Planning Policy Framework (NPPF) seek to promote sustainable

transport and Policy 7.26 of the London Plan seek to increase the use of the Blue Ribbon Network for freight transport. With these policy aims and objectives in mind, the Applicant should be encouraged to place further consideration on adhering to these policy criteria.'

Response:

26. The appointed contractor will assess the feasibility of using the River for the delivery of goods and removal of waste associated with the construction. However, it should be noted that whilst the site is located in close proximity to the River Thames the only direct access to the River is via a narrow strip of land to the east of Anchor and Hope Lane and the site is otherwise surrounded by roads and developed land. The strip of land that leads towards the River connects with the Thames Path rather than directly with a river or a dock site.
27. Obtaining of concrete aggregates from local suppliers will be considered by the appointed contractors. However, it should be noted that there are many commercial factors that determine what supplier is used and this cannot be solely based on proximity.
28. The Transport Assessment assumed that all materials will be transported by road. Should any materials be transported in a different way then this will have a positive impact on the road network. As such, the assessment undertaken is robust.
29. Making a presumption in direct favour of the use of a specific wharf would not be appropriate when examining environmental impacts would be incorrect and heavily criticised upon such an assumption.

Issue: Promotion of river based transport

'No consideration appears to have been given to the promotion of river based transport, which would accord with the River Action Plan (February 2013) and draft Transport Strategy. The River Action Plan and London Plan itself assert the importance of promoting sustainable travel, and outlines a number of specific measures to be taken by Transport for London (TfL) and other stakeholders to help boost the number of river trips.'

Response:

30. As set out in the adopted Charlton Riverside SPD, river services are expected to serve a new Charlton Riverside pier. This is not a proposal of the applicant but is an aspect considered over the longer term by the council as part of the overall regeneration for the area. However, the pier is outside the scope of this application and the exact location and frequency is not known. Therefore it would be premature to be promoting the use of river services at this early stage.
31. The closet existing river taxi passenger pier used by Thames Clippers services from the site is at North Greenwich located approximately 2km away. The Transport Assessment has followed guidance provided by TfL in respect of assessment of river services which advise that these need to be included as part of the baseline conditions for developments which are located within 750 metres of a pier. As can be seen the proposed development does not currently meet this criteria. Therefore the assessment that has been undertaken has followed the appropriate guidance. The Travel Plan also includes reference to river transport services and this would be the appropriate way in which the promotion of river services is undertaken.

Issue: Consideration of the River Bus including the Woolwich Ferry

'The site is in relative proximity to Barrier Gardens Pier on the River Thames itself, as such the PLA would like to see consideration given to the use of the River Bus, including the Woolwich Ferry, as an alternative form of sustainable transport. The need to reduce our carbon footprint and establish sustainable communities is paramount within National Policy. The use of the river as an alternative transport method would therefore aid in promoting the objective of sustainable communities within the Borough. Information on the following is required to be provided by way of condition to the planning decision (should planning permission be forthcoming):

- 1. Provision of targets for river bus use (which reflect the targets set out within the River Action Plan);*
- 2. Measures to encourage river bus use*
- 3. Timetable for River Bus stop.'*

Response:

32. As mentioned above, the TfL guidance states that river services be considered and promoted for schemes that are located with 750m of a pier. North Greenwich Pier is located some 2km away from the site with Woolwich Ferry located over 2.5km away. The Barrier Gardens Pier is situated circa 1km away but is only be served by occasional leisure boats which require pre-booking and does not form part of the commuter river piers used by Thames Clipper river taxi services.
33. As such there is no justification for detailed consideration to be provided regarding the use of the River Bus beyond general promotion within the Travel Plan.

Response to Proposed Conditions

'The PLA would like to see an appropriately worded condition imposed on any forthcoming planning consent requesting the submission and upon approval, implementation, of a River Transport Plan.'

34. Given that the site is not currently within 750m of a pier, a River Transport Plan is not considered necessary and this should not form part of any planning consent.

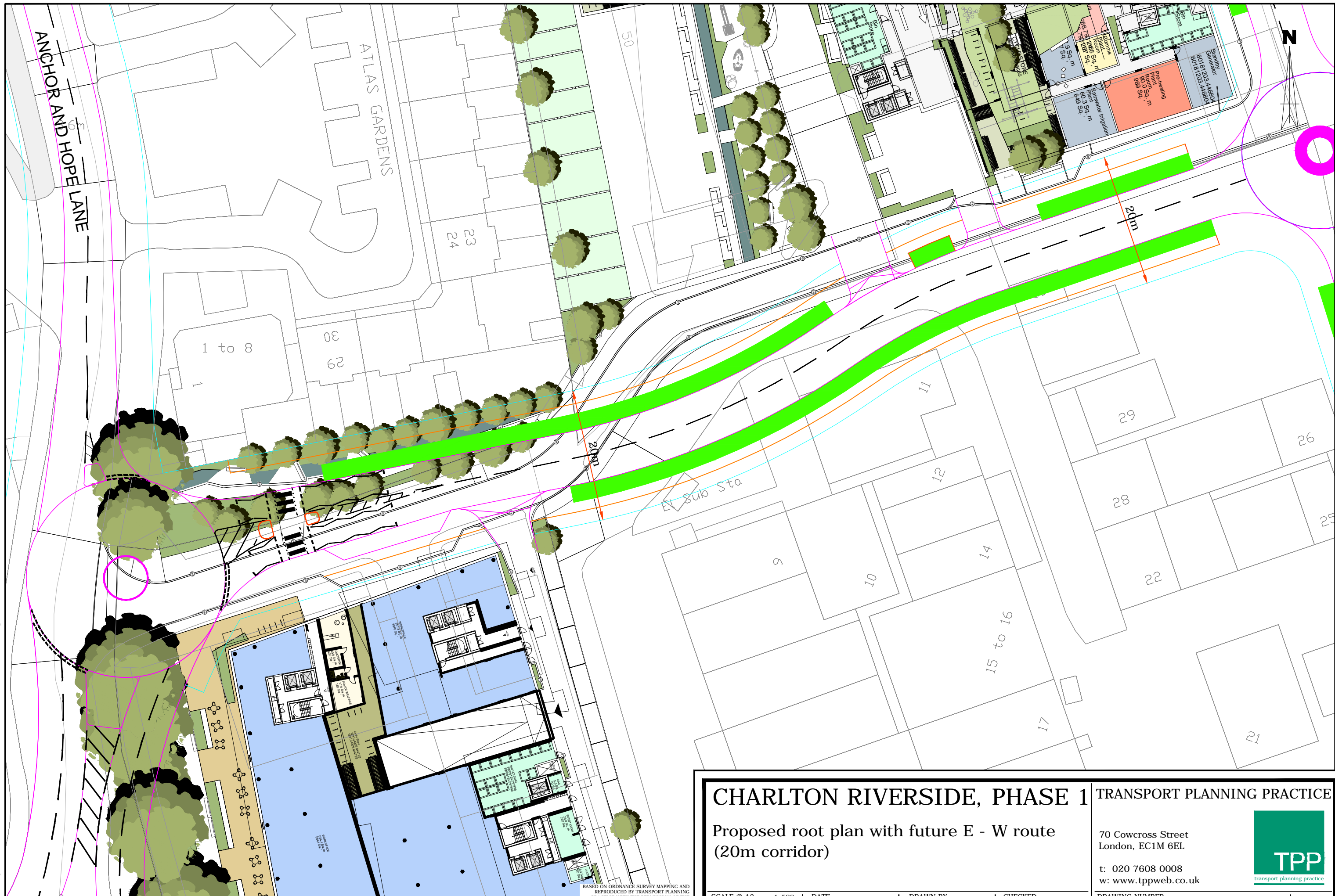

ANCHOR AND HOPE LANE

ATLAS GARDENS

23
24

1 to 8

30
29

20m

EV Sub Sta

11

12

9

10

14

15 to 16

17

28

22

21

29

26

25

Pre-heating Plant
960.0 Sq. m
969 Sq. m

Wastewater Treatment
601.3 Sq. m
649 Sq. m

Wastewater Treatment
601.3 Sq. m
649 Sq. m

Wastewater Treatment
601.3 Sq. m
649 Sq. m

Wastewater Treatment
601.3 Sq. m
649 Sq. m

Wastewater Treatment
601.3 Sq. m
649 Sq. m

Wastewater Treatment
601.3 Sq. m
649 Sq. m

Wastewater Treatment
601.3 Sq. m
649 Sq. m

Wastewater Treatment
601.3 Sq. m
649 Sq. m

Wastewater Treatment
601.3 Sq. m
649 Sq. m

Wastewater Treatment
601.3 Sq. m
649 Sq. m

Wastewater Treatment
601.3 Sq. m
649 Sq. m

Wastewater Treatment
601.3 Sq. m
649 Sq. m

Wastewater Treatment
601.3 Sq. m
649 Sq. m

Wastewater Treatment
601.3 Sq. m
649 Sq. m

Wastewater Treatment
601.3 Sq. m
649 Sq. m

Wastewater Treatment
601.3 Sq. m
649 Sq. m

Wastewater Treatment
601.3 Sq. m
649 Sq. m

Wastewater Treatment
601.3 Sq. m
649 Sq. m

Wastewater Treatment
601.3 Sq. m
649 Sq. m

Wastewater Treatment
601.3 Sq. m
649 Sq. m

Wastewater Treatment
601.3 Sq. m
649 Sq. m

CHARLTON RIVERSIDE, PHASE 1 TRANSPORT PLANNING PRACTICE

Proposed root plan with future E - W route
(20m corridor)

70 Cowcross Street
London, EC1M 6EL

t: 020 7608 0008
w: www.tppweb.co.uk



DRAWING NUMBER

30821/AC/217

REV

A

This drawing has been prepared for planning purposes and should not be used for construction. It should be read in conjunction with TPP e-mail of 14/02/18.

BASED ON ORDNANCE SURVEY MAPPING AND REPRODUCED BY TRANSPORT PLANNING PRACTICE WITH THE PERMISSION OF THE CONTROLLER OF HMSO © CROWN COPYRIGHT
Based on drawing number 10046-A-DRG-ZO-G100-2030-PL-RS
TPP REF - IN_115.

SCALE @ A3 1:500

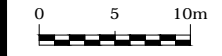

DATE

14/02/18

DRAWN BY

LD

CHECKED

CW

T:\30000_Projects\30821 Charlton Riverside, Greenwich\ACAD\2017 scheme\217.dwg

RBG Waste/ Street Services Further Comments		
1.	<p>5) Understands that the developer has used a number methodologies to arrive at a final number of waste and recycling containers, however suggests that the methodology from the RBG guidance notes should be used above all else. Suggests that their rationale for this is that the methodology allows for 'future proofing' of the waste capacity for the lifetime of the building. If waste production habits, or collection methods be altered due to a future change in legislation we need to have capacity to accommodate this. Notes that it is also in the benefit of the building owner to have ample capacity to minimise dumping in the bin store and maintaining safe, clean, bin storage.</p>	<p>The number of waste containers for all waste streams within the proposed development has been established using the RBG Guidance and will be provided on this basis. The reference to the British Standards and the Building Regulations was made to highlight that a lower amount of containers would be expected to be sufficient for the proposed development when the unit sizes are considered in calculating waste generation, which the RBG Guidance does not take account of. Therefore, when the weekly collections are made to the development it would be unlikely that these total waste bins would need to be presented and collected by the council operatives at ground level and through site management to the basement main waste rooms. Thus a lower number of bins would need to be transferred during collections using the lifts.</p>
2.	<p>7) Confirms they are happy for WEEE, Textiles and batteries to be centralised for use of a number of residents, rather than in individual bin stores. Requests that this location is shown on plan and the number of proposed containers detailed. The 240L bins mentioned for organic waste have not been shown on plan. Recommends the use of a 500L organic waste bin in each store as per RBG's guidance notes.</p>	<p>This is noted although the weight of the 500l organic waste bin would be significantly higher compared with other waste streams. It would be more practical to include two x 240L bins instead, and provides a similar volume of container..</p>
3.	<p>9) States that with regards to the ground floor collection points it should be noted that RBG will only be able to empty bins if they are presented upon arrival. The collection crew will not be obliged to wait for containers to be brought up from the basement level, nor will they make a return trip to collect waste that has not been presented. Therefore, suggests that a larger collection point would facilitate all bins being emptied at once, bearing in mind that bringing approx. 45 bins up in pairs will be a lengthy process.</p>	<p>This aspect has been considered as part of the design with a balance being made between the on site management of waste storage and the provision of active frontage around the base of the buildings.</p> <p>The architect has prepared a sketch indicating the implications that the provision for larger ground floor waste collection rooms for Plot A and B would have in relation to the ground floor arrangements of the scheme.</p>
4.	<p>10) Confirms they are happy for a manual bin tug to be used as a contingency plan in the event of lift breakdown.</p>	<p>Noted.</p>
5.	<p>13) Notes that bin tugs may have a 4 tonne capacity, however in practise no</p>	<p>Noted. However, it is also noted that significantly longer waste bin chains can be observed within mainline railway concourses during peak periods on a</p>

	more than 4no. 1100L bins can safely be towed in a chain at one time.	frequent basis where 8 to 10 bins in a single chain are pulled through passenger areas.
6.	14) Requests that the bulk waste store for block B is shown on plan.	This is shown on the basement plan for Plot B immediately west of the main centralised bin store but highlighted in grey rather than yellow.
7.	16) Notes that regardless of weather or fleet difficulties, RBG residential waste operations occur Monday – Friday 06:00 – 20:00. Therefore, suggests that it should not be expected that early morning collections will occur at this development.	Noted and agreed.
Transport for London		
Future Transport Connections		
8.	Concerned that the development proposal would preclude the delivery of east – west route as envisaged by RB Greenwich.	<p>The location of Plot B is to the south of the east-west route and the design of the buildings within this Plot have been further adjusted so that they would not preclude the future delivery of a 24m East-West Link Road as set out in the Charlton Riverside SPD.</p> <p>The development proposals for the site have always been cognisant of the wider Charlton Riverside Masterplan and have been developed around a general framework of highway infrastructure. As neither RBG nor their appointed masterplan team had prepared a sufficiently detailed drawing the applicant has prepared such a plan to enable the preparation of development schemes on their plots. This information has been provided to RBG as part of the discussions following the submission of the planning application in response to the consultation comments on the scheme.</p>
9.	Suggests that the location of Plot B would preclude the provision of an eastern arm to the Bugsby's Way and Anchor and Hope Lane junction to provide a link to Charlton Riverside.	<p>The location of the western end of the East-West Link Road and its connection to Anchor and Hope Lane was discussed with RBG during the evolution of the Charlton Riverside SPD as part of the council's consultation with stakeholders. From the plans within the Charlton Riverside SPD, the route does not form an additional arm of the existing roundabout, but is indicated to connect Anchor and Hope Lane to the north of the existing Roundabout with Bugsby's Way. Therefore, this comment appears to be an error by TfL in their interpretation</p>

		<p>of the Charlton Riverside SPD document.</p> <p>The East-West Link Road (24m wide corridor) can be provided off a new junction to the north of Plot B on Anchor and Hope Lane, rather than off the Bugsby's Way/Anchor and Hope Lane junction. This has been accounted for in the amendments to the plans for this Plot.</p>
10.	<p>Concerned by the proposed junction arrangement between the site access, Anchor and Hope Lane and Bugsby's Way. Suggests that under this arrangement it would appear difficult to implement measures to prioritise movements of buses in and out of the Charlton Riverside OA.</p>	<p>Whilst the Charlton SPD makes reference to a bus route through the overall master plan along the East-West Route, there is no indication that any bus priority measures are being considered along Anchor and Hope Lane or at the entrance to the master plan area at the western end of the East-West Link Road. Indeed, the SPD states that the bus priority (bus gate) measures would be at its eastern end. It would therefore be unreasonable to expect the applicant to show additional road width on their drawings in the absence of detailed proposals within the SPD. Furthermore, the SPD states at 7.4 of the document that the East West Link:</p> <p><i>"It is not intended to provide an alternative route for strategic through traffic which remains on the A206/SRN. Access will be restricted to local journeys and access, public transport, cyclists and emergency vehicles, via a mechanism such as a bus gate, at the eastern end of the new link. "</i></p> <p>Additionally at 7.2 of the Adopted SPD the proposals for the routes within the Master Plan area are described as:</p> <p><i>"On-street parking and the use of bus boxes, rather than lay-bys will help to manage traffic speeds, as will the prevalence of junctions and pedestrian crossings."</i></p> <p>Therefore it is clear that the flows of traffic on the East West link are intended to relate to the development and the location of the bus priority measures described as being at the eastern end, and not in the location of the proposed development, according to the Adopted SPD. Also the use of 'bus boxes' does not infer the need for bus lanes along its route.</p>
11.	<p>Concerned that the proposed development proposal would preclude the delivery of a high quality public transport link considered vital to the</p>	<p>Please see response above with reference to Chapter 7 of the Charlton</p>

	realisation of the vision for the Charlton Riverside OA.	Riverside SPD..
Existing Site Connectivity		
12.	Confirms that they are satisfied with the analysis undertaken and confirms agreement with the average PTAL score.	Noted.
Future Site Connectivity		
13.	Notes that the PTAL assessment should be taken as a guide to what potential PTAL could be achieved, however this should not be relied upon to justify departures from the London Plan housing density matrices.	<p>It is reasonable to expect public transport improvements to come forward in order to support the Opportunity Area as stated in the Charlton Riverside SPD, June 2017. It is noted that the SPD also refers to future PTAL scores in Figure 6.3 on Page 62 stating that these are based on the proposed changes/improvements to public transport provision and an improved level of pedestrian accessibility. The assumptions within the Transport Assessment are therefore in line with those set out in the SPD. On examining Figure 6.3 of the SPD, it would appear that this has been produced by TfL using their WebCAT assessment tool. Therefore it is peculiar that TfL are suggesting that this should not be relied upon as the TPP assessment relates very closely to this.</p> <p>It is also noted that in the letter, TfL are seeking financial contributions to bus services to increase the frequency of routes in the immediate area. This further indicates that there ought to be some level of certainty with regard to the public transport improvements with the implementation of the Master Plan over time. With the proposed contribution levels suggested by TfL for the proposed development applied to the overall master plan for 7,500 dwellings the result would be circa £8m towards bus service enhancements, along with the additional revenue created through the additional patronage. With this level of funding, it would be expected that enhancements to services would be delivered by TfL. If not, then the contributions would be expected to be returned to each of the developers after a suitable period of time.</p>

Site Access, Layout and Healthy Streets		
14.	<p>Suggests that in line with Policy T2 of the Draft New London Plan the development should be designed appropriately to support mode shift towards active and public transport travel and the designs for new or enhanced streets must demonstrate how they deliver against the ten Healthy Streets Indicators.</p>	<p>The roads within the development have been designed to be highly permeable in terms of access for pedestrians and cyclists. A series of improvements to pedestrian facilities are proposed on and off-site as set out within the Transport Assessment. The assessment of the development against the Healthy Street Indicators is set out below:</p> <ul style="list-style-type: none"> • <i>Pedestrians from all walks of life</i> – The proposed development will deliver residential accommodation consisting of different unit and tenure mix resulting in a mixed community. • <i>People choose to walk, cycle and use public transport</i> – Car parking at the proposed development will be low at 0.27 spaces per reflecting the accessibility of the site by walking, cycling and public transport. The non-residential elements of the scheme will have no general car parking. As set out in the Transport Assessment, the majority of trips are predicted to be undertaken on foot, by cycle and by public transport. • <i>Clean air</i> – Limited car parking and associated low level of vehicle generation will help to achieve this. • <i>People feel safe</i> - The pedestrian environment within the application site will be of high quality with the provision of an attractive open space, well maintained and with legible illuminated pedestrian routes, natural/passive surveillance provided by the commercial elements and residential lobbies of the application site. The proposed development will also contribute to the perception of pedestrian safety by enhancing the public realm and increasing natural surveillance of pedestrian routes. • <i>Not too noisy</i> – Limited car parking and associated low vehicle generation will help to achieve this. • <i>Easy to cross</i> – Limited car parking and low vehicle generation as well as additional crossing points will help to achieve this. • <i>Places to stop and rest</i> – Seating will be provided within the public realm. • <i>Shade and shelter</i> – Trees and landscaping will be provided within the public realm. • <i>People feel relaxed</i> – The pedestrian environment will be of high quality with extensive public realm proposals.

		<ul style="list-style-type: none"> • <i>Things to see and do</i> – The proposed development will provide a mixed use scheme in what is currently an industrial development. The scheme will create new connections such as e.g. the link to the Thames path. <p>It would also be expected that RBG and TfL would follow the guidance within the SPD in developing the routes within the master plan area and <i>“All streets will be designed with reference to The Government’s Manual for Streets (2007), so that design speeds, road geometry, forward visibility, street furniture and materials, and general arrangement, will tend towards creating an environment where the needs and safety of pedestrians is paramount.”</i> (Ref 7.2 Charlton Riverside SPD) and also that <i>“its streets will be designed in line with the principles of Transport for London’s Healthy Streets Framework”</i> (Ref 7.6 Charlton Riverside SPD). This will also relate to RBG’s delivery of the East-West Link Road.</p>
15.	<p>Whilst the proposed layout serves the immediate needs of the proposed development and allows access to both car parking areas, there appears to be limited information on how this access route will facilitate access by foot or cycle to the wider masterplan area and how it has been designed to not prejudice any future plans.</p>	<p>The roads within the proposed scheme will eventually connect with the wider masterplan although no sufficiently detailed drawings have been produced to date by RBG or their consultants which would indicate what the proposed scheme is expected to tie in to.</p> <p>Therefore, the Applicant has had to work up plans for the proposed master plan roads for the Master Plan in the absence of any detailed specific plans from RBG in order to progress the 2016 and 2017 planning applications. Throughout the process cognisance has been taken of these routes, making allowance for a 24m corridor for the future delivery by RBG of the East West Link Road to be provided. Therefore, the future access through the master plan has been provided for.</p> <p>In addition, pedestrian and cycle connections through the development proposals to Anchor and Hope Lane (between Derrick Gardens and Atlas Gardens) and to the Thames Path.</p>

16.	Requests that the applicant set out how the proposed development will fit into, and facilitate, the future proposals for the site, without precluding any potential future transit route.	Again, there are no detailed plans available from RBG or TfL which the proposed scheme layout could tie in to. However the Applicant has taken the future provision of the East-West Link Road into account in developing the proposals, and the adjustments to the Plot B buildings have been made to enable this to be provided by RBG in the future.
17.	Suggests that the proposed access from Hope and Anchor Lane and the Bugsby's Way/Anchor and Hope Lane roundabout should be investigated in further detail.	<p>The proposed East-West Link Road will be provided off a new junction to the north of Plot B rather than the existing roundabout junction of Bugsby's Way and Anchor and Hope Lane. This follows the Charlton Riverside SPD.</p> <p>A diagram showing this has been provided as part of the application and the consultation process.</p>
Walking and Cycling Infrastructure and Access		
18.	Notes that the applicant has identified potential opportunities to contribute positively to the local pedestrian/cycle network. Suggests they would welcome further discussions with both the applicant and RBG on the mechanism for delivering these improvements and how they fit in with the overall movement strategy for the masterplan area.	<p>Noted.</p> <p>Proposals for improvements have been submitted as part of the development proposals on Anchor and Hope Lane. In addition, connecting routes through the site are included within the site for improved connections between Anchor and Hope Lane (between Derrick Gardens and Atlas Gardens) and the Thames Path.</p>
Trip Generation and Approach to Assessment		
19.	Confirms the methodology proposed to assess the trip generation for the residential element of this particular site is appropriate and acceptable to TfL.	Noted.
20.	Notes that the approach to the assessment of the non-residential trip generation is accepted, however suggests that it should be noted that the assumed daily profile of arrival and departures for office employees is taken from the Canary Wharf Employee Travel Survey undertaken in 2007 and should be updated.	This set of data is still considered valid and appropriate for the purposes of establishing the proportion of staff arrival and departure trips in the AM and PM peak hours. It is unlikely that significant changes to the profile of arrivals and departures have altered since 2007 which would result in a higher level of trips within the peaks. If anything, the peaks will have reduced through the current trend towards more flexible working and home working. Thus, the figures used within the Transport Assessment are robust and would provide a worse case assessment of the peak trips.

21.	Notes that the approach to the assessment of the ancillary uses is also accepted.	Noted
22.	Notes that in relation to the nursery, whilst the trip generation methodology is accepted, and the lack of drop-off and pick-up facilities welcomed, the applicant will need to have consideration to the fact that despite a lack of provision to do so, parents are still likely to drop-off and pick-up children on the way to/from work using private vehicles. Suggests the site design will need to provide a response to the likely scenario that people will attempt to park close to the nursery and pick-up/drop-off children. Suggests that the design of the internal streets will need to be carefully developed with these issues in mind.	<p>The assessed impact of the nursery has been undertaken to ensure that a robust assessment of the impacts on traffic flows around the adjacent highway network represent a worse case. However, the main purpose of the nursery is to provide for a local need largely related to this development and the immediate surrounding area. Thus it would be expected that the primary catchment area would be local and walkable.</p> <p>All car use to the nursery will be discouraged and the nursery operator will enforce the message that there will be no facilities for car parking or drop-off / pick-up within the vicinity of the site. It is possible that the internal shared surface area between buildings DEF and GH could be used to provide for a car drop off and pick up facility, subject to the management of the space as it would not amount to a high level of use of this space. However, the specific provision within the site for dedicated parking for this specific use would then result in a difficulty in reducing and minimising car use, and is against planning policy guidance to minimise private car use.</p>
Public Transport Impact Assessment		
23.	Expects contributions from this development in order to facilitate improvements to the bus network and mitigate the expected increase in demand. Suggests that a contribution of £830,000 would be required to enhance bus services or facilitate infrastructure as appropriate. This would	This is noted.

	facilitate the introduction of an increase in the frequency of routes in the immediate area to cater for the additional demand. This is based upon the introduction of four new journeys across an initial period of 3 years.	
24.	It is noted that as discussed at the pre-application meeting, TfL are interested in the potential impact of an additional number of passengers accessing Charlton station, and it was requested that these are set out clearly within the TA due to TfL's potential future interest in the station and services operating from it.	The predicted number of rail passengers arising from the proposed development is set out in Section 19 of the Transport Assessment. During the AM peak hour a total of extra 122 passengers are forecast with 103 extra passengers in the PM peak hour. The assessment shows that the largest impact on the rail network arising from the extra passengers at Charlton station is expected to be 1.1% which would occur in the weekday AM peak hour due to outbound trips. This is equivalent to an average of 10 passengers per train in one direction.
Car Parking		
25.	Suggests there should be 78 Blue Badge spaces included within the development compared to the 51 proposed.	The proposed accessible car parking provision significantly exceeds the Draft New London Plan minimum requirements of 3% of residential dwellings by a multiple of 2. In addition, this level also exceeds the minimum of 10% of the parking provision required to be suitable for use as accessible bays as set out in the Borough's planning policy. Together with the car park management plan, it also complies with the Accessible London SPG and the currently adopted London Plan. Car parking will be managed so as to give priority to blue badge holders and will allow for parking layout to be amended to achieve disabled parking at a level of 10% of the units, should the need arise.
26.	Suggests the TA should provide more details regarding the management and allocation of the ultimately agreed Blue Badge parking.	Details on how the car park will be operated will be provided within a Car Park Management Plan and it will be proposed that a right to park arrangement will be implemented and renewed on an annual basis, in order to allow priority to be given to blue badge holders and parking bays to be re-allocated on a needs basis. This is wholly in line with the adopted policies, and this is set out within the Transport

		Assessment.
27.	Suggests the applicant seeks to meet the requirements of the Draft New London Plan which requires any parking to be provided with 20% active charging points with all the remaining spaces provided with passive provision.	Noted. However, it is also noted that this policy is Draft and not currently adopted. An appropriate adopted policy compliant condition securing the necessary minimum provisions would be expected to be imposed.
28.	Expects the applicant to commit to a condition on the development for all future residents (except Blue Badge holders) prevented from applying for a residents parking permit.	Noted and agreed.
29.	Suggests the development should also fund an extension of the Charlton (C) Controlled Parking Zone to cover the extent of their development	The roads within the site would be privately owned and so the CPZ would not apply. In terms of Anchor and Hope Lane, on-street parking, this is already included as part of the Charlton CPZ, despite the bays having a different regime of restrictions.
Cycle Parking		
30.	Notes that there is a lack of detail on the type or location of this provision, except for the statement within the TA that they will be at ground and basement levels. Notes that there was no basement plan provided within the suite of planning drawings submitted and as such the layout cannot be reviewed. Requests that these should be included.	Noted. The basement plan was prepared with a layout of cycle parking, however, this may have been a layering issue. A detailed replacement plan has been prepared. This has been undertaken by the Architect.
31.	Notes that there is no mention of the provision of showers and storage facilities for the non-residential uses across the site, which should be confirmed.	Shower and storage facilities are expected to be provided for the proposed workspace. Currently, the proposed commercial space is provided as 'shell and core' to allow flexibility in the future fit out by operators or tenants. As such it would be suitable for this provision to be subject to a planning condition.

32.	Suggests residential or commercial visitor cycle parking located in the public realm will need to be designed to avoid any fly-parking around the site which may affect pedestrian or servicing vehicle flows and building entrances.	Visitors' cycle parking will be spread across various locations within the site. The provision is in line with the TfL standards and therefore there will be sufficient spaces to cater for visitors' demand for cycle spaces. In any event, the maintenance of the landscaping and operations within the site will be dealt with by the on-site management of the private estate.
33.	Notes that as there is a lack of information on the provision of facilities cycle parking, TfL cannot determine whether the number, type or location of cycle parking is acceptable.	The cycle parking provision would be expected to be conditioned and therefore details would normally be provided as a pre-occupation condition. The cycle parking types used will be a mixture of two-tier racks and Sheffield stands for larger bikes such as cargo bikes and tri-cycles etc.
Travel Plan		
34.	We welcome that modal shift targets are included in the Travel Plan, however as set out within TfL's Travel Plan Guidance when using percentages as a target, it is important to ensure values are correctly quantified. The targets should clearly differentiate between percentage point reduction/increases as opposed to percentage reduction/increases.'	The proposed targets are consistent with the Travel Plan Guidance and also consistent with how targets are expressed by TfL for individual mode increases for sustainable travel within London. This form of figures has been used and accepted by local authorities for setting targets on travel plans that have been implements. It should be noted that this is a Framework Travel Plan and the targets are provisional at this stage and will need to be revised once the baseline modal split has been established.
35.	Requests that a draft Construction Logistics Plan (CLP) is produced prior to determination.	The Transport Assessment includes an assessment of the impacts associated with construction traffic and the Environmental Statement includes a dedicated chapter on construction and demolition activities. It would be expected that a Construction Logistics Plan would be conditioned.

Appendix B

Drawings

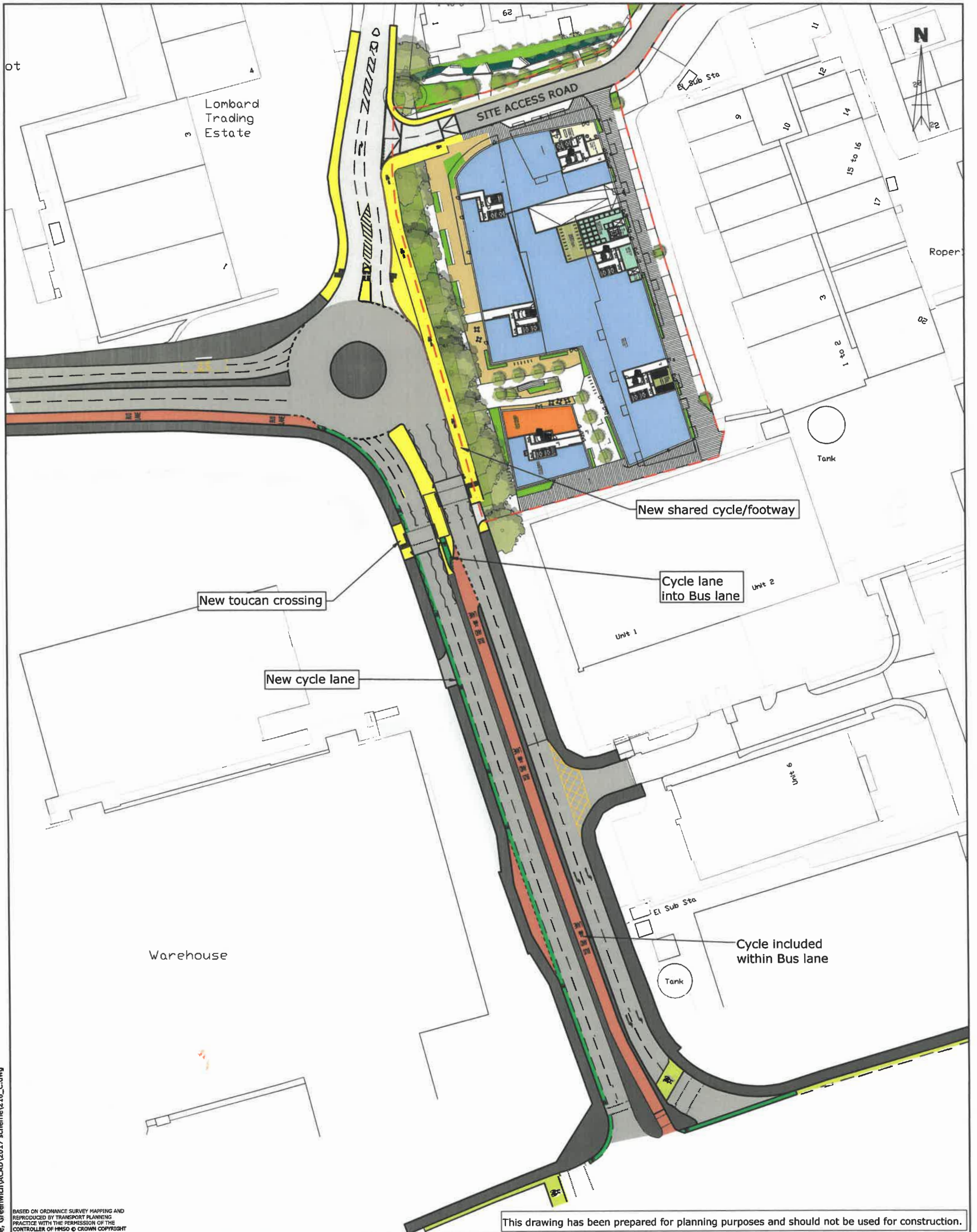

This drawing has been prepared for planning purposes and should not be used for construction.

T:\30000_Projects\30821 Charlton Riverside, Greenwich\CAD\2017 scheme\216_C.dwg

BASED ON ORDINANCE SURVEY MAPPING AND REPRODUCED BY TRANSPORT PLANNING PRACTICE WITH THE PERMISSION OF THE CONTROLLER OF HMSO © CROWN COPYRIGHT

Key

- Site boundary
- Cycle lane works
- Footway/cycle lane works
- carriageway works

CHARLTON RIVERSIDE, GREENWICH

Highway works

TRANSPORT PLANNING PRACTICE

70 Cowcross Street
London, EC1M 6EL

t: 020 7608 0008
w: www.tppweb.co.uk

TPP
transport planning practice

SCALE @ A3 1:1000	DATE	DRAWN BY	CHECKED	DRAWING NUMBER	REV
0 10 20m	15/10/18	LD	CW	30821/AC/216	C

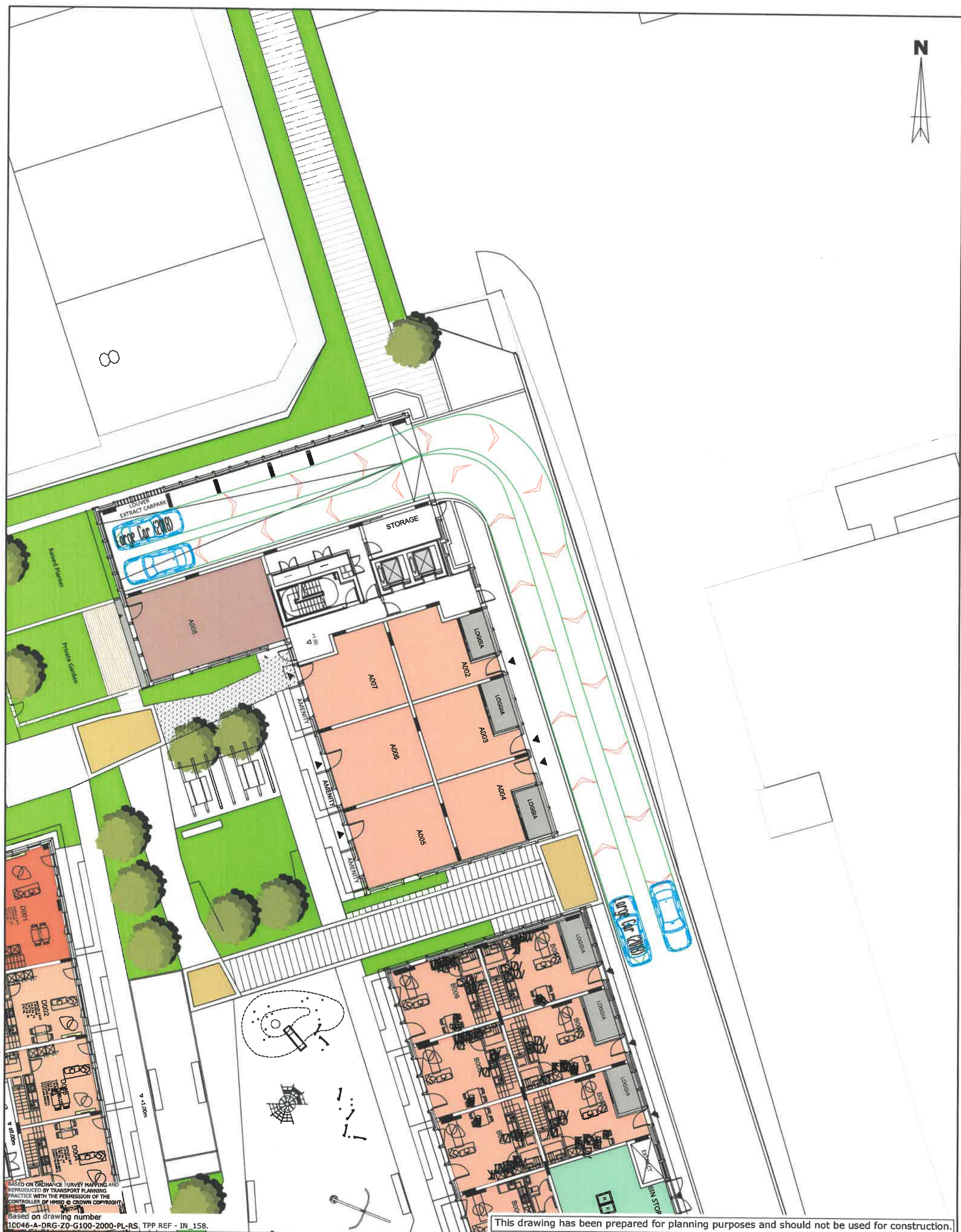

T:\30000_Projects\30821 Charlton Riverside, Greenwich\ACAD\2017 scheme\232 - 235.dwg

BASED ON ORDINANCE SURVEY MAPPING AND REPRODUCED BY TRANSPORT PLANNING PRACTICE WITH THE PERMISSION OF THE CONTROLLER OF HMSO © CROWN COPYRIGHT.
Based on drawing number 10046-A-DRG-Z0-G100-2000-PL-RS, TPP REF - IN 158.

This drawing has been prepared for planning purposes and should not be used for construction.

Vehicle used	
Large Car (2018)	5.196m
Overall Length	1.944m
Overall Width	1.524m
Overall Body Height	0.090m
Min Body Ground Clearance	1.918m
Max Track Width	4.00s
Lock to lock time	6.150m
Kerb to Kerb Turning Radius	

CHARLTON RIVERSIDE, GREENWICH

Plot A

Car park access/egress

Swept path analysis of large car

TRANSPORT PLANNING PRACTICE
70 Cowcross Street
London, EC1M 6EL
t: 020 7608 0008
w: www.tppweb.co.uk



SCALE @ A3	1:250	DATE	15/10/18	DRAWN BY	LD	CHECKED	CW

DRAWING NUMBER	30821/AC/232	REV	-
----------------	--------------	-----	---

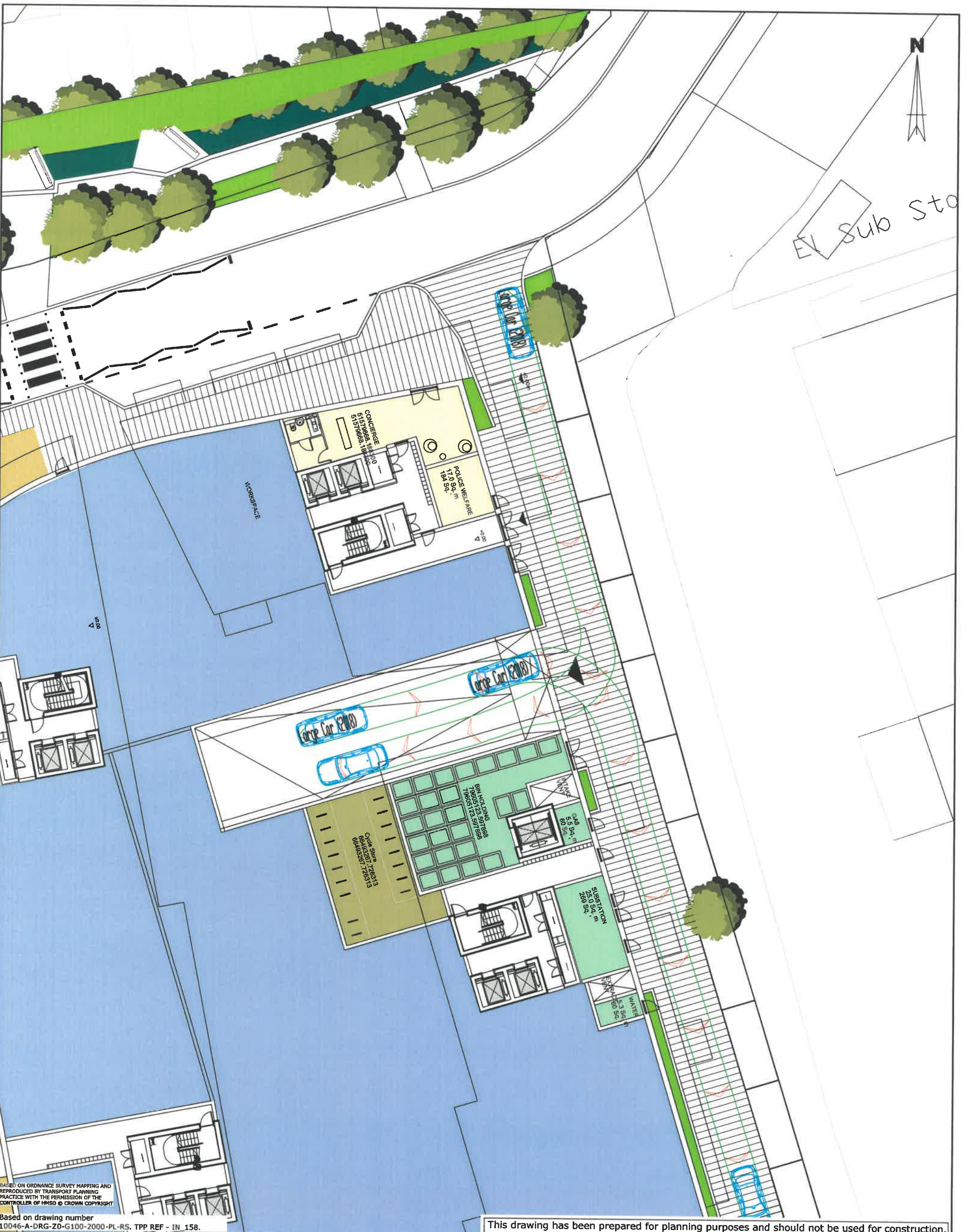

T:\30000_Projects\30821 Charlton Riverside, Greenwich\ACAD\2017 scheme\232 - 235.dwg

BASED ON ORDNANCE SURVEY MAPPING AND REPRODUCED BY TRANSPORT PLANNING PRACTICE WITH THE PERMISSION OF THE CONTROLLER OF HMSO © CROWN COPYRIGHT

Based on drawing number 10046-A-DRG-Z0-G100-2000-PL-RS, TPP REF - IN_158.

This drawing has been prepared for planning purposes and should not be used for construction.

Vehicle used	
Large Car (2018)	5.196m
Overall Length	1.944m
Overall Width	1.524m
Overall Body Height	0.090m
Min Body Ground Clearance	0.090m
Max Track Width	1.918m
Lock to lock time	4.00s
Kerb to Kerb Turning Radius	6.150m

CHARLTON RIVERSIDE, GREENWICH

Plot B
Car park access/egress
Swept path analysis of large car

SCALE @ A3 1:250
DATE 15/10/18

DRAWN BY LD
CHECKED CW

TRANSPORT PLANNING PRACTICE

70 Cowcross Street
London, EC1M 6EL

t: 020 7608 0008
w: www.tppweb.co.uk



DRAWING NUMBER 30821/AC/233

REV -



BASED ON ORDINANCE SURVEY MAPPING AND REPRODUCED BY TRANSPORT PLANNING PRACTICE WITH THE PERMISSION OF THE CONTROLLER OF HMSO © CROWN COPYRIGHT

Based on drawing number 10046-A-DRG-Z0-G100-2000-PL-RS. TPP REF - IN_158.

This drawing has been prepared for planning purposes and should not be used for construction.

T:\130000_Projects\30821 Charlton Riverside, Greenwich\ACAD\2017 scheme\232 - 235.dwg

Vehicle used

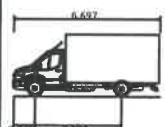

Tranist Cab L4
 Overall Length 6.697m
 Overall Width 2.507m
 Overall Body Height 2.863m
 Min Body Ground Clearance 0.233m
 Max Track Width 1.945m
 Lock to lock time 4.00s
 Kerb to Kerb Turning Radius 7.000m

CHARLTON RIVERSIDE, GREENWICH

Plot A
 3.5t LGV servicing (6.5m)

SCALE @ A3 1:500
 0 5 10m

DATE 15/10/18

DRAWN BY LD

CHECKED CW

TRANSPORT PLANNING PRACTICE

70 Cowcross Street
 London, EC1M 6EL

t: 020 7608 0008
 w: www.tppweb.co.uk



DRAWING NUMBER 30821/AC/234

REV -



BASED ON ORDNANCE SURVEY MAPPING AND REPRODUCED BY TRANSPORT PLANNING PRACTICE WITH THE PERMISSION OF THE CONTROLLER OF HMSO © CROWN COPYRIGHT

Based on drawing number 10046-A-DRG-Z0-G100-2000-PL-RS. TPP REF - IN_158.

This drawing has been prepared for planning purposes and should not be used for construction.

T:\30000_Projects\30821 Charlton Riverside, Greenwich\ACAD\2017 scheme\232 - 235.dwg

Vehicle used

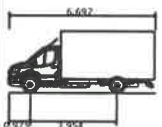

Tranist Cab L4
 Overall Length 6.697m
 Overall Width 2.507m
 Overall Body Height 2.233m
 Min Body Ground Clearance 1.949m
 Max Track Width 4.00s
 Lock to lock time 4.00s
 Kerb to Kerb Turning Radius 7.000m

CHARLTON RIVERSIDE, GREENWICH

Plot B
 3.5t LGV servicing (6.5m)

TRANSPORT PLANNING PRACTICE

70 Cowcross Street
 London, EC1M 6EL

t: 020 7608 0008
 w: www.tppweb.co.uk



SCALE @ A3 1:500
 0 5 10m

DATE 15/10/18

DRAWN BY LD

CHECKED CW

DRAWING NUMBER 30821/AC/235

REV -



BASED ON ORDNANCE SURVEY MAPPING AND REPRODUCED BY TRANSPORT PLANNING PRACTICE WITH THE PERMISSION OF THE CONTROLLER OF HMSO © CROWN COPYRIGHT
 Based on layout, 10046-A-DRG-Z0-G100-2000-PL-RS. TPP In_158

This drawing has been prepared for planning purposes and should not be used for construction.

Vehicle used	
FTA Design HG Rigid Vehicle (1998)	10.000m
Overall Length	2.500m
Overall Width	3.645m
Overall Body Height	0.440m
Min Body Ground Clearance	2.470m
Track Width	3.00s
Lock to Lock Time	11.000m
Kerb to Kerb Turning Radius	

CHARLTON RIVERSIDE, GREENWICH

Plot A
 Swept path analysis of 10.0m Rigid HGV

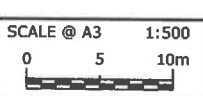

SCALE @ A3 1:500
 DATE 15/10/18

DRAWN BY LD

CHECKED CW

TRANSPORT PLANNING PRACTICE

70 Cowcross Street
 London, EC1M 6EL

t: 020 7608 0008
 w: www.tppweb.co.uk



DRAWING NUMBER 30821/AC/209

REV C

T:\30000_Projects\30821 Charlton Riverside, Greenwich\ACAD\2017 scheme\209_C - 212_C.dwg



BASED ON ORDNANCE SURVEY MAPPING AND REPRODUCED BY TRANSPORT PLANNING PRACTICE WITH THE PERMISSION OF THE CONTROLLER OF HMSO © CROWN COPYRIGHT

Based on layout, 10046-A-DRG-Z0-G100-2000-PL-RS. TPP In_158

This drawing has been prepared for planning purposes and should not be used for construction.

T:\30000_Projects\30821 Charlton Riverside, Greenwich\ACAD\2017 scheme\209_C - 212_C.dwg

Vehicle used	
FTA Design HG Rigid Vehicle (1998)	10.000m
Overall Length	2.500m
Overall Width	3.445m
Overall Body Height	0.440m
Min Body Ground Clearance	2.470m
Track Width	3.00s
Lock to Lock Time	11.000m
Kerb to Kerb Turning Radius	

CHARLTON RIVERSIDE, GREENWICH

Plot B
Swept path analysis of 10.0m Rigid HGV

TRANSPORT PLANNING PRACTICE

70 Cowcross Street
London, EC1M 6EL

t: 020 7608 0008
w: www.tppweb.co.uk

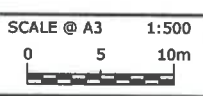

SCALE @ A3 1:500
DATE 15/10/18

DRAWN BY LD

CHECKED CW

DRAWING NUMBER 30821/AC/210

REV C



T:\30000_Projects\30821 Charlton Riverside, Greenwich\ACAD\2017 scheme\209_C - 212_C.dwg

BASED ON ORDINANCE SURVEY MAPPING AND REPRODUCED BY TRANSPORT PLANNING PRACTICE WITH THE PERMISSION OF THE CONTROLLER OF HMSO © CROWN COPYRIGHT

Based on layout, 10046-A-DRG-Z0-G100-2000-PL-RS. TPP In_158

This drawing has been prepared for planning purposes and should not be used for construction.

Vehicle used	
Phoenix 2-20W (with Elite 2 6x2 RS chassis)	
Overall Length	10.220m
Overall Width	2.530m
Overall Body Height	3.211m
Min Body Ground Clearance	0.416m
Track Width	2.530m
Lock to Lock Time	4.00s
Kerb to Kerb Turning Radius	6.800m

CHARLTON RIVERSIDE, GREENWICH

Plot A
Swept path analysis of 10.2m refuse vehicle

SCALE @ A3	1:500	DATE	15/10/18	DRAWN BY	LD	CHECKED	CW
------------	-------	------	----------	----------	----	---------	----

TRANSPORT PLANNING PRACTICE

70 Cowcross Street
London, EC1M 6EL

t: 020 7608 0008
w: www.tppweb.co.uk



DRAWING NUMBER	30821/AC/211	REV	C
----------------	--------------	-----	---



BASED ON ORDNANCE SURVEY MAPPING AND REPRODUCED BY TRANSPORT PLANNING PRACTICE WITH THE PERMISSION OF THE CONTROLLER OF HMSO © CROWN COPYRIGHT

Based on layout, 10046-A-DRG-Z0-G100-2000-PL-RS. TPP In_158

This drawing has been prepared for planning purposes and should not be used for construction.

CHARLTON RIVERSIDE, GREENWICH

Plot B Swept path analysis of 10.2m refuse vehicle

TRANSPORT PLANNING PRACTICE

70 Cowcross Street
London, EC1M 6EL

t: 020 7608 0008
w: www.tppweb.co.uk



Vehicle used	
Phoenix 2-20W (with Elite 2 6x2 RS chassis)	10.220m
Overall Length	2.530m
Overall Width	3.211m
Overall Body Height	0.415m
Min Body Ground Clearance	2.530m
Track Width	4.00s
Lock to Lock Time	6.800m
Kerb to Kerb Turning Radius	

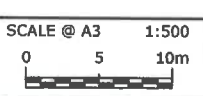

DATE
15/10/18

DRAWN BY
LD

CHECKED
CW

DRAWING NUMBER
30821/AC/212

REV
C

T:\30000_Projects\30821 Charlton Riverside, Greenwich\ACAD\2017 scheme\209_C - 212_C.dwg

T:\30000_Projects\30821 Charlton Riverside, Greenwich\ACAD\2017 scheme\213_C.dwg



Vehicle used	
Winnibago	10.970m
Overall Length	7.400m
Overall Width	2.699m
Overall Body Height	0.370m
Min Body Ground Clearance	2.400m
Track Width	4.065
Lock to Lock Time	12.200m
Kerb to Kerb Turning Radius	

This drawing has been prepared for planning purposes and should not be used for construction.

BASED ON ORDNANCE SURVEY MAPPING AND REPRODUCED BY TRANSPORT PLANNING PRACTICE WITH THE PERMISSION OF THE CONTROLLER OF HMSO © CROWN COPYRIGHT

Based on layout, drawing 10046-A-DRG-Z0-G100-2000-PL-RS . TPP REF - IN_158.

CHARLTON RIVERSIDE, GREENWICH

Swept path analysis of an RV accessing Imex House

SCALE @ A3
0 2.5 5m

1:250
DATE
10/10/18

DRAWN BY
LD

CHECKED
CW

TRANSPORT PLANNING PRACTICE

70 Cowcross Street
London, EC1M 6EL

t: 020 7608 0008
w: www.tppweb.co.uk



DRAWING NUMBER
30821/AC/213

REV
C

T:\30000_Projects\30821 Charlton Riverside, Greenwich\CAD\2017 scheme\231_A.dwg

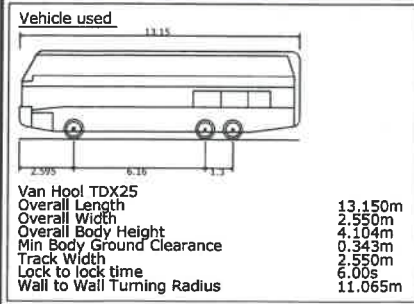

This drawing has been prepared for planning purposes and should not be used for construction.

BASED ON ORDNANCE SURVEY MAPPING AND REPRODUCED BY TRANSPORT PLANNING PRACTICE WITH THE PERMISSION OF THE CONTROLLER OF HMSO © CROWN COPYRIGHT
 Based on layout, drawing 10046-A-DRG-Z0-G100-2000-PL-RS.
 TPP REF - IN_158.

<h2>CHARLTON RIVERSIDE, GREENWICH</h2> <h3>Swept path analysis of a 13.1m coach</h3> <h3>Imex House</h3>		<h2>TRANSPORT PLANNING PRACTICE</h2> <p>70 Cowcross Street London, EC1M 6EL</p> <p>t: 020 7608 0008 w: www.tppweb.co.uk</p>	
<p>SCALE @ A3 1:250</p>	<p>DATE 10/10/18</p>	<p>DRAWN BY LD</p>	<p>CHECKED CW</p>
<p>DRAWING NUMBER 30821/AC/231</p>		<p>REV A</p>	





T:\30000_Projects\30821 Charlton Riverside, Greenwich\ACAD\2017 scheme\228_b.dwg

This drawing has been prepared for planning purposes and should not be used for construction.

BASED ON ORDINANCE SURVEY MAPPING AND REPRODUCED BY TRANSPORT PLANNING PRACTICE WITH THE PERMISSION OF THE CONTROLLER OF HMSO © CROWN COPYRIGHT

Based on drawing number 10046-A-DRG-Z0-G100-2000-PL-RS
TPP REF - IN_158.

CHARLTON RIVERSIDE, PHASE 1 TRANSPORT PLANNING PRACTICE

Proposed future E - W route (24m corridor)

70 Cowcross Street
London, EC1M 6EL
t: 020 7608 0008
w: www.tppweb.co.uk



SCALE @ A3	1:1000	DATE	DRAWN BY	CHECKED	DRAWING NUMBER	REV
0 10 20m		25/09/18	LD	CW	30821/AC/228	B

APPENDIX 8.1A

Traffic Data

Link	Additional Cumulative Schemes October 2018	
	24 hour AADT	
	All Motor Vehicles	HGVs (> 3.5tonnes incl. buses and coaches)
Anchor & Hope Lane North of Bugsby's Way	0	0
Anchor & Hope Lane North of Site Access	0	0
Anchor & Hope Lane South of Bugsby's Way	0	0
Bugby's Way West of Gallions Road	0	0
Bugby's Way East of Gallions Road	0	0
Charlton Church Lane North of Delafield Way	0	0
A206 East of Anchor & Hope Lane	574	52
A206 West of Anchor & Hope Lane	574	52
Site Access	0	0
Gallions Road	0	0

Link	Original Cumulative Schemes	
	24 hour AADT	
	All Motor Vehicles	HGVs (> 3.5tonnes incl. buses and coaches)
Anchor & Hope Lane North of Bugsby's Way	0	0
Anchor & Hope Lane North of Site Access	0	0
Anchor & Hope Lane South of Bugsby's Way	1,606	17
Bugby's Way West of Gallions Road	1,606	17
Bugby's Way East of Gallions Road	1,606	17
Charlton Church Lane North of Delafield Way	193	3
A206 East of Anchor & Hope Lane	1,675	17
A206 West of Anchor & Hope Lane	568	8
Site Access	0	0
Gallions Road	0	0

Link	New Current Cumulative Schemes (Original Schemes + October 2018 Schemes)	
	24 hour AADT	
	All Motor Vehicles	HGVs (> 3.5tonnes incl. buses and coaches)
Anchor & Hope Lane North of Bugsby's Way	0	0
Anchor & Hope Lane North of Site Access	0	0
Anchor & Hope Lane South of Bugsby's Way	1,606	17
Bugby's Way West of Gallions Road	1,606	17
Bugby's Way East of Gallions Road	1,606	17
Charlton Church Lane North of Delafield Way	193	3
A206 East of Anchor & Hope Lane	2,250	69
A206 West of Anchor & Hope Lane	1,142	60
Site Access	0	0
Gallions Road	0	0

Link	(3a) Future Baseline (Existing plus other cumulative schemes)	
	24 hour AADT	
	All Motor Vehicles	HGVs (> 3.5tonnes incl. buses and coaches)
Anchor & Hope Lane North of Bugsby's Way	3,293	481
Anchor & Hope Lane North of Site Access	2,019	336
Anchor & Hope Lane South of Bugsby's Way	22,415	2,857
Bugby's Way West of Gallions Road	25,438	3,752
Bugby's Way East of Gallions Road	23,460	3,696
Charlton Church Lane North of Delafield Way	6,774	556
A206 East of Anchor & Hope Lane	41,202	6,034
A206 West of Anchor & Hope Lane	24,126	3,550
Site Access	1,385	148
Gallions Road	5,172	17

Link	(3a) New Future Baseline (Existing plus other cumulative schemes)	
	24 hour AADT	
	All Motor Vehicles	HGVs (> 3.5tonnes incl. buses and coaches)
Anchor & Hope Lane North of Bugsby's Way	3,293	481
Anchor & Hope Lane North of Site Access	2,019	336
Anchor & Hope Lane South of Bugsby's Way	22,415	2,857
Bugby's Way West of Gallions Road	25,438	3,752
Bugby's Way East of Gallions Road	23,460	3,696
Charlton Church Lane North of Delafield Way	6,774	556
A206 East of Anchor & Hope Lane	41,777	6,086
A206 West of Anchor & Hope Lane	24,700	3,602
Site Access	1,385	148
Gallions Road	5,172	17

Link	(4.) Cumulative Traffic Flows (Existing minus current Site operation + proposed development + other cumulative schemes)	
	24 hour AADT	
	All Motor Vehicles	HGVs (> 3.5tonnes incl. buses and coaches)
Anchor & Hope Lane North of Bugsby's Way	3,796	415
Anchor & Hope Lane North of Site Access	1,983	330
Anchor & Hope Lane South of Bugsby's Way	22,658	2,821
Bugby's Way West of Gallions Road	25,690	3,724
Bugby's Way East of Gallions Road	23,731	3,669
Charlton Church Lane North of Delafield Way	6,822	548
A206 East of Anchor & Hope Lane	41,445	6,004
A206 West of Anchor & Hope Lane	24,134	3,548
Site Access	1,852	77
Gallions Road	5,181	16

Link	(4.) New Cumulative Traffic Flows (Existing minus current Site operation + proposed development + other cumulative schemes)	
	24 hour AADT	
	All Motor Vehicles	HGVs (> 3.5tonnes incl. buses and coaches)
Anchor & Hope Lane North of Bugsby's Way	3,796	415
Anchor & Hope Lane North of Site Access	1,983	330
Anchor & Hope Lane South of Bugsby's Way	22,658	2,821
Bugby's Way West of Gallions Road	25,690	3,724
Bugby's Way East of Gallions Road	23,731	3,669
Charlton Church Lane North of Delafield Way	6,822	548
A206 East of Anchor & Hope Lane	42,019	6,056
A206 West of Anchor & Hope Lane	24,708	3,600
Site Access	1,852	77
Gallions Road	5,181	16

APPENDIX 9.1A

Site Suitability Update

TECHNICAL APPENDIX 9.4: SITE SUITABILITY UPDATE

The likely effect of noise sources within the study area at the location of the proposed residential units within the proposed development has been assessed in line with the guidance provided within Professional Practice Guidance (ProPG) on Planning & Noise developed by the Institute of Acoustics and BS8233¹.

ProPG considers new residential development that will be exposed predominantly to airborne noise from transport sources. The preparation of this guidance was overseen by a Working Group consisting of representatives of the Association of Noise Consultants (ANC), Institute of Acoustics (IOA) and Chartered Institute of Environmental Health (CIEH), together with practitioners from a planning and local authority background.

This guidance has been produced to provide practitioners with guidance on a recommended approach to the management of noise within the planning system in England. It takes into account the guidance on the control and mitigation of noise detailed in the National Planning Policy Framework (NPPF) and the Noise Policy Statement for England (NPSE) and presents them in one overall document. It also provides further clarification and guidance for appropriate noise levels and suitable design, such as proposing suitable maximum noise levels in bedrooms at night.

Figure 1 below summarises the assessment methodology which has been used to assess site suitability.

¹ Institute of Acoustics, 2017. Planning & Noise: Professional Practice Guidance on Planning & Noise

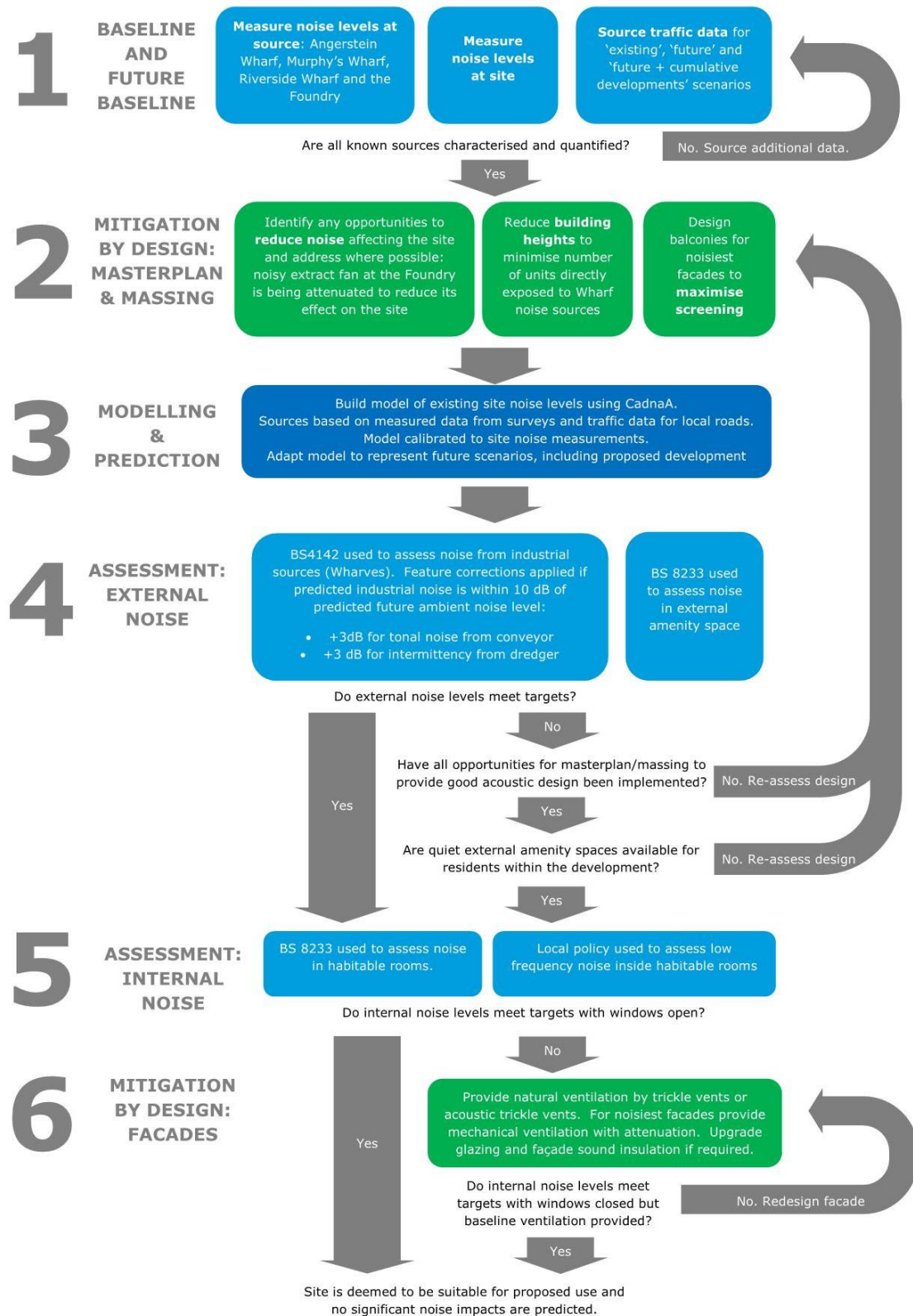

Figure 1: Site Suitability Assessment Methodology Flowchart

Further details of each aspect of the assessment are provided in the following sections.

1.1 Noise Criteria

Industrial Noise Affecting the Site

Suitable criteria for determining the impact of the Safeguarded Wharves and the Stone Foundries on the site are based on the guidance in BS 4142: 2014².

The basis of BS 4142: 2014 is a comparison between the background noise level in the vicinity of residential locations and the rating level of the noise source under consideration. The relevant parameters in this instance are as follows:

- Background Sound Level: LA90,T – defined in the Standard as the 'A' weighted sound pressure level that is exceeded by the residual sound at the assessment location for 90% of a given time interval, T, and quoted to the nearest whole number of decibels (dB);
- Specific Sound Level: LAeq,Tr – the equivalent continuous 'A' weighted sound pressure level produced by the specific sound source at the assessment location over a given time interval, T;
- Residual Sound Level: LAeq,T – the equivalent continuous 'A' weighted sound pressure level at the assessment location in the absence of the specific sound source under consideration, over a given time interval, T; and
- Rating Level: LAr,Tr – the specific sound level plus any adjustment made for the characteristic features of the noise.

The background level and the rating levels are compared and the standard states that:

"Typically, the greater the difference, the greater the magnitude of impact.

A difference of around +10 dB or more is likely to be an indication of a significant adverse impact, depending upon the context.

A difference of around +5 dB is likely to be an indication of an adverse impact, depending upon the context."

The lower the rating level is to the measured background sound level, the less likely it is that the specific sound will have an adverse impact or a significant adverse impact. Where the rating level does not exceed the background sound level, this is an indication of the specific sound source having a low impact, depending upon the context.

The standard specifies the specific sound level as an LAeq with a one-hour assessment period during the day (07:00-23:00 hours) and a fifteen-minute assessment period at night (23:00-07:00 hours).

Ambient Noise in External Amenity Spaces

The noise levels in external amenity areas have been assessed against the guidance contained in BS 8233:2014. The adopted significance threshold for noise in external amenity spaces is the 55 dB LAeq,18hr 'upper limit' from BS 8233.

ProPG Stage 2: Element 3 – External Amenity Area Noise Assessment, states the following:

"3(v) Where, despite following a good acoustic design process, significant adverse noise impacts remain on any private external amenity space (e.g. garden or balcony) then that impact may be partially off-set if the residents are provided, through the design of the development or the planning process, with access to:

- a relatively quiet façade (containing openable windows to habitable rooms) or a relatively quiet externally ventilated space (i.e. an enclosed balcony) as part of their dwelling; and/or

² British Standards Institution, 2014. British Standard 4142:2014 Method for Rating and Assessing Industrial and Commercial Sound. BSI.

- a relatively quiet, protected, publically accessible, external amenity space (e.g. a public park or a local green space designated because of its tranquillity) that is nearby (e.g. within a 5 minutes walking distance)."

Internal Ambient Noise Levels

The internal ambient noise levels have been assessed against the guidance within BS 8233: 2014. BS 8233:2014 recommends that for resting/sleeping conditions in living rooms and bedrooms, the internal noise levels should not exceed 35 dB LAeq,16hour and 30 dB LAeq,8hour for daytime and night time respectively.

These internal daytime and night-time ambient noise level criteria have been adopted as the significance thresholds for this assessment.

Tonal Noise Inside Dwellings

It is understood that RBG local policy is that tonal noise from industrial noise sources should not exceed 50 dB Leq,63Hz(oct) inside dwellings.

This has been adopted as the significance criterion for tonal noise inside dwellings.

1.2 Baseline and Future Baseline

Noise measurements were undertaken to quantify the noise climate at the site and the noise produced by the adjacent Stone Foundries site and the nearby safeguarded wharf (Riverside Wharf) as described in Technical Appendix 9.2: Baseline Noise Survey.

Following this survey through consultation with the wharf operators, additional noise data was gathered on the contribution of noise from the more distant safeguarded wharfs (Murphy's and Angerstein's Wharfs). Further noise surveys were undertaken at these sites, as described in Technical Appendix 9.2: Baseline Noise Survey.

1.3 Mitigation by Design – Masterplan and Massing

Following the baseline noise survey in June 2016, the noise of a single extract fan at the Stone Foundries site was found to dominate the noise climate on the eastern elevations of the proposed development. Following discussions with the Ramboll Acoustic Consultant and the Stone Foundries, it is understood that the Applicant is in the process of assisting with the provision of attenuation of this fan in order to reduce its noise impact on the proposed development. This potential reduction has not been taken into account in this assessment in order to present a worst case view but is expected to be in place by commencement of construction of the proposed development and can therefore be factored into the detailed design of façades and ventilation strategies.

The November 2016 proposed development included tall buildings which did not benefit from any noise screening from the intervening buildings between the site and Angerstein's and Murphy's Wharves. Following discussions between the Ramboll Acoustic Consultant, Architect and the Applicant, it was agreed that a better acoustic design could be achieved with a lower-rise development. This would ensure that the maximum number of residents would benefit from the screening of intervening properties. This approach has been taken in response to a number of planning issues and is incorporated into the revised design.

The design of the balconies for the noisy façades was discussed between the Acoustic Consultant and the Architect. Two different balcony designs were developed which would enable those elevations which are exposed to the highest noise levels to achieve the best practicable reduction in noise, by recessing the balconies within the building façades. Once the above mitigation had been designed into the scheme, the noise impacts could be predicted.

1.4 Modelling and Prediction

Noise levels at the site have been predicted the Cadna/A suite of noise modelling software. This software utilises standard acoustic principles in conjunction with approved prediction methodologies and is an industry method for predicting and assessing the impact of noise from a variety of sources.

The noise model considers the baseline and cumulative 2023 traffic flows³ (including background traffic growth in proximity to the site) within the study area, based on traffic flow data provided by the Applicant's Transport Consultant, as detailed in the Road Traffic Noise section. Traffic flows for each link under each considered scenario are presented in full in Technical Appendix 9.5.

The site was assumed to comprise acoustically reflecting '50% hard ground'. All buildings were assumed as acoustically reflecting. The model was set to consider three-orders of reflection and to assume light downwind propagation in all directions. This is considered to represent a typical worst case in terms of noise propagation from the roads within the study area.

The following noise sources were incorporated into the model:

- Plant noise from the Stone Foundries;
- Operational noise from Riverside Wharf and Angerstein and Murphy's safeguarded wharves to the northeast and northwest of the site in accordance with the measurements presented in Technical Appendix 9.2;
- Docking and unloading noise from dredger ships at Murphy's Wharf in accordance with the measurements presented in Technical Appendix 9.2; and
- Traffic links surrounding the site as per the traffic flows shown in Technical Appendix 9.5.

1.5 Assessment: External Noise

Industrial Noise

BS 4142 has been used to assess noise from industrial sources (i.e., Riverside, Angerstein and Murphy's Wharves, Stone Foundries). The outcome of the noise model shows that that the predicted industrial noise is within 10 dB of predicted future ambient noise level (i.e. potentially audible). Therefore, the following feature corrections were applied to the noise model:

- +3 dB for tonal noise from dredger activities; and
- +3 dB for intermittency from dredger activities.

The predicted noise levels from the industrial noise sources including these feature corrections can be seen in Figure 2 and Figure 3. The figures also show the measured background noise levels (LA90) at certain locations as described in Technical Appendix 9.2.

³ The opening year has been revised from 2023 as presented in the 2017 ES, to 2024. Given the background traffic levels have remained stable for the past few years, no background growth factor was being applied for future baseline forecasts, as agreed with RBG and TfL for the assessment. Therefore the revised opening date of 2024 would, under this agreed methodology for future forecasts, result in the same assessment baseline traffic. Thus the operational traffic flows used within the 2017 ES remain robust and valid for the purposes of assessment within this appendix and Chapter 9: Noise and Vibration.



Figure 2: Predicted Noise Levels from Industrial Noise Sources (Safeguarded Wharves) – Plot A

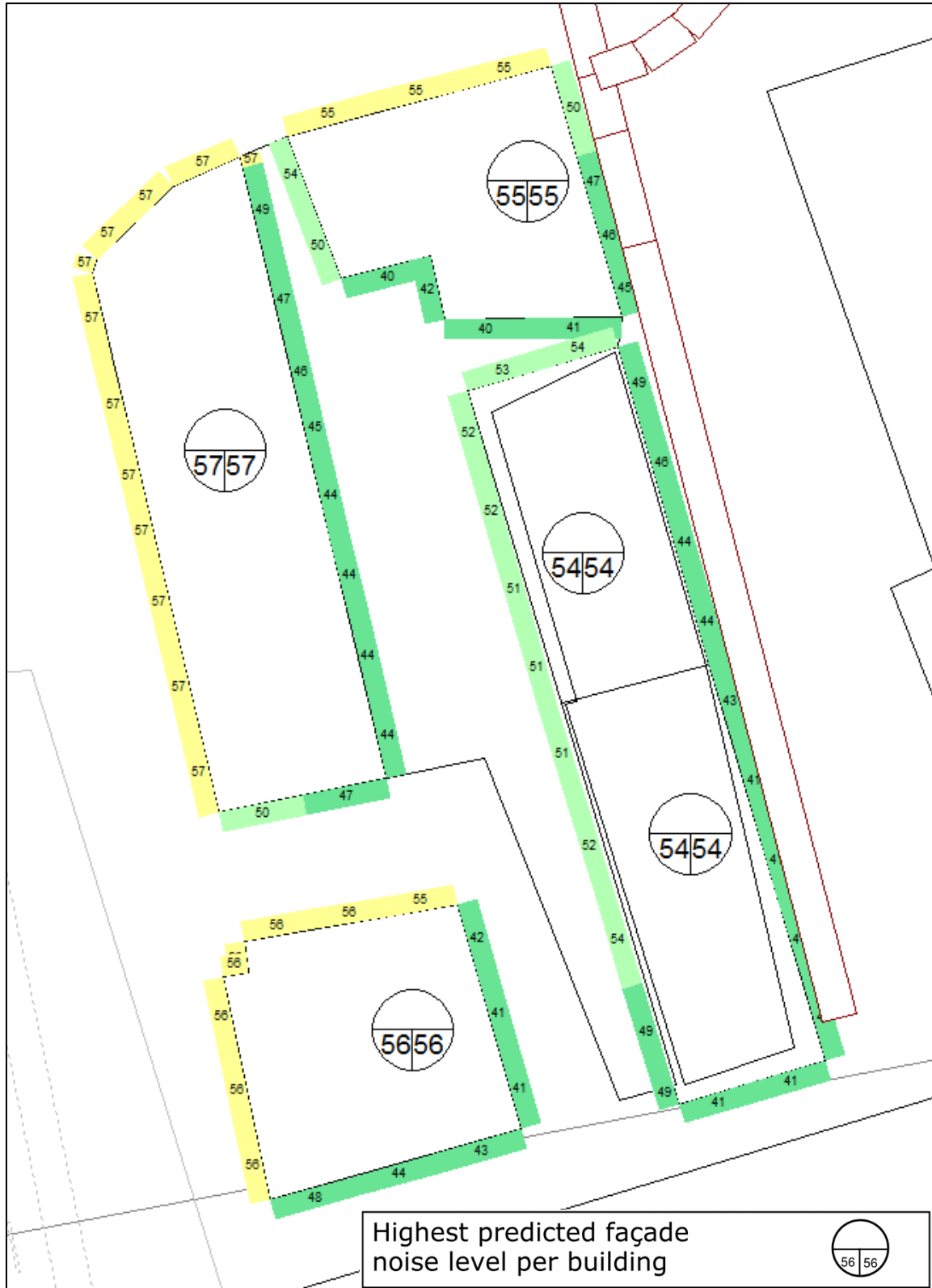

Figure 3: Predicted Noise Levels from Industrial Noise Sources (Safeguarded Wharves) – Plot B

As stated within Technical Appendix 9.2, the night-time background noise levels across the site are around 48 dB along Anchor and Hope Lane and around 53 dB near the western façades of

plot A. The difference between the rating level and the background noise level is shown in Table 1.

Table 1 Difference Between Rating Level and Background Noise Level			
Building	Worst case Rating level, i.e. most exposed façade (dB)	Background noise levels during night-time (dB)	Difference*
Building A	59	53	+6dB
Building B	67	53	+14dB
Building C	62	53	+9dB
Building D	57	48	+9dB
Building E	56	48	+8dB
Building F	56	48	+8dB
Building G	55	48	+7dB
Building H	55	48	+7dB
Building J	44	50	+6dB
Building K+L	54	48	+6dB
Building M+N	57	50	+7dB
Building O	56	48	+8dB

* According to BS 4142:2014, a difference of around +10 dB or more is likely to be an indication of a significant adverse impact, depending upon the context. Therefore, such differences are highlighted in red.

On the basis of the above results and in line with the guidance presented in BS 4142, significant impacts could occur at the most exposed façades of Building B as a result of industrial noise affecting the amended proposed development. However, with the provision of design mitigation discussed below, it is possible to reduce the magnitude of effects.

For Building B, the dominant industrial noise source is the extract fan at the Stone Foundries, which is subject to a plan to provide attenuation. This could be secured by planning condition. With the provision of a suitably specified attenuator it is considered that the Rating level affecting these locations would fall below the significance threshold.

On this basis, **no significant effects** are predicted as a result of industrial noise levels affecting the site.

Ambient Noise in External Amenity Areas

The proposed landscape masterplan showing the location of the proposed amenity spaces can be found in ES Addendum Chapter 4A: The Proposed Development.

The external amenity areas on the balconies and roof tops have been predicted and are outlined in Table 2. They are numbered according to building, façade direction (east, west etc), position (as shown in Figure 4 and Figure 5) and storey level. For example. B1 west 2.0G would be building B, point 1, west façade, level 2.



Figure 4: Plot A - Predicted Noise Levels at External Amenity Spaces

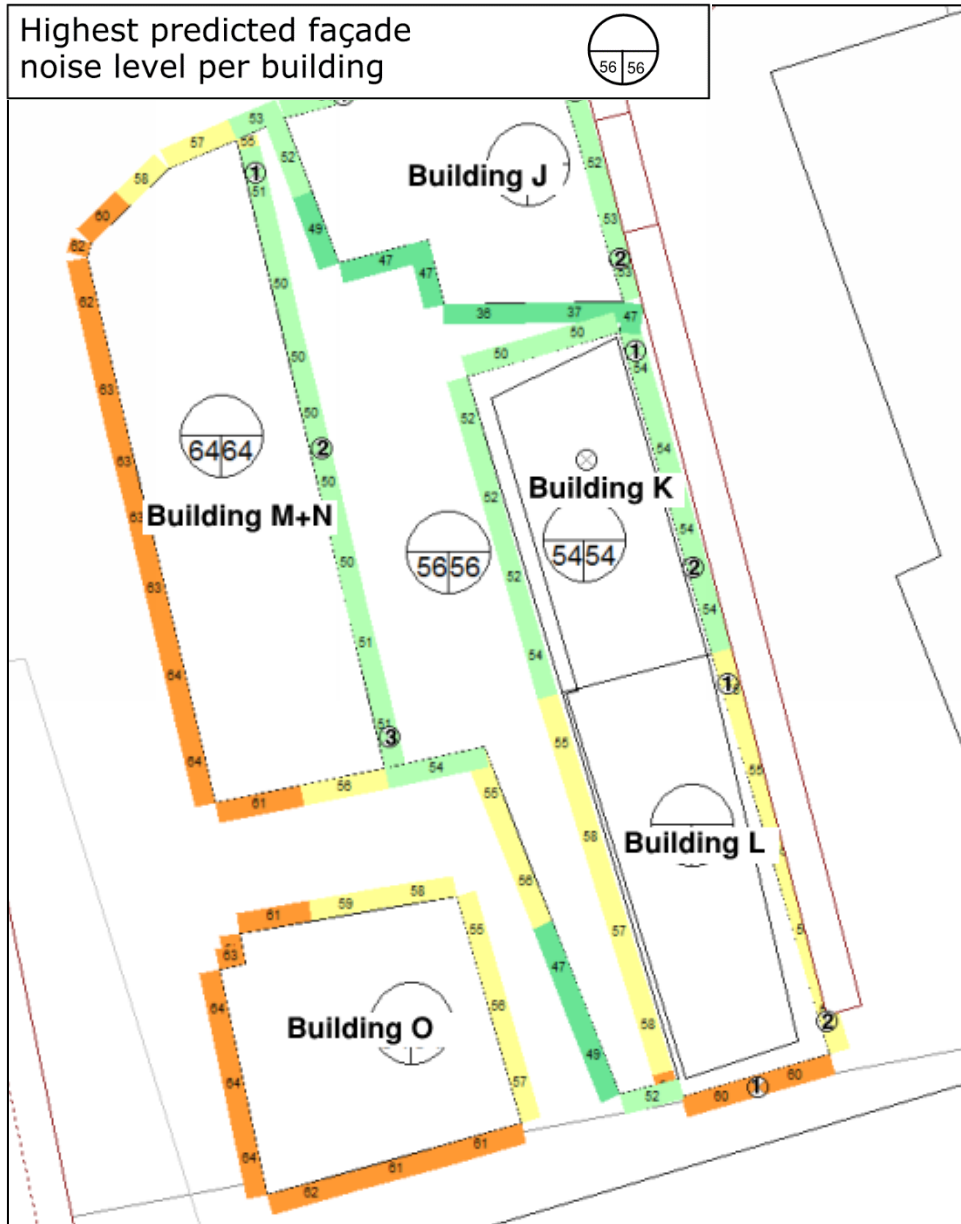

Figure 5: Plot B - Predicted Noise Levels at External Amenity Spaces

Table 2 Predicted Balcony, Podiums, Rooftop Amenity Spaces Noise Levels							
Building	Sound Pressure Level / dBA	Building	Sound Pressure Level / dBA	Building	Sound Pressure Level / dBA	Building	Sound Pressure Level / dBA
A rooftop	48.1	C5 west 1.OG	48.3	F1 east 1.OG	44.2	M1 east 1.OG	41.6
A rooftop	49.8	C5 west 2.OG	50.6	F1 east 2.OG	47	M1 east 2.OG	45
B rooftop	48.3	C5 west 3.OG	51.9	F1 east 3.OG	48.1	M1 east 3.OG	48.3
B rooftop	48.2	C5 west 4.OG	52.5	F1 east 4.OG	48.5	M1 east 4.OG	49.3
B2 east 1.OG	60.3	C5 west 5.OG	52.9	F1 east 5.OG	48.6	M1 east 5.OG	49.9
B2 east 2.OG	60.1	C5 west 6.OG	53.1	F1 east 6.OG	48.6	M1 east 6.OG	50.2
B2 east 3.OG	59.6	C5 west 7.OG	53.2	F1 east 7.OG	48.7	M1 east 7.OG	50.4
B2 east 4.OG	59	C5 west 8.OG	53.4	F1 east 8.OG	48.9	M1 east 8.OG	50.6
B2 east 5.OG	58.4	C5 west 9.OG	53.6	F1 east 9.OG	49.3	M1 east 9.OG	50.9
B2 east 6.OG	57.6	C5 west EG	43.8	F1 east EG	39.6	M1 east EG	38.9
B2 east 7.OG	56.9	D1 east 1.OG	41.3	F1 west 1.OG	47.6	M2 east 1.OG	43
B2 east 8.OG	56.2	D1 east 2.OG	43.4	F1 west 2.OG	49.1	M2 east 2.OG	44.6
B2 east 9.OG	55.6	D1 east 3.OG	47.2	F1 west 3.OG	50.9	M2 east 3.OG	46.8
B2 east EG	60.3	D1 east 4.OG	47.5	F1 west 4.OG	52.2	M2 east 4.OG	47.7
B2 west 1.OG	41.5	D1 east 5.OG	47.6	F1 west 5.OG	53.3	M2 east 5.OG	48.2
B2 west 2.OG	44.3	D1 east 6.OG	47.7	F1 west 6.OG	54	M2 east 6.OG	48.5
B2 west 3.OG	47.5	D1 east 7.OG	47.9	F1 west 7.OG	54.4	M2 east 7.OG	48.6
B2 west 4.OG	48.2	D1 east 8.OG	48.2	F1 west 8.OG	54.6	M2 east 8.OG	48.8
B2 west 5.OG	48.5	D1 east 9.OG	48.9	F1 west 9.OG	54.8	M2 east 9.OG	49.2
B2 west 6.OG	48.9	D1 east EG	38.5	F1 west EG	45.1	M2 east EG	39.5
B2 west 7.OG	49.3	D1 west 1.OG	47.4	F2 east 1.OG	46.9	M3 east 1.OG	45.2
B2 west 8.OG	50.1	D1 west 2.OG	48	F2 east 2.OG	49.3	M3 east 2.OG	47.2
B2 west 9.OG	51.6	D1 west 3.OG	49.6	F2 east 3.OG	50.6	M3 east 3.OG	49
B2 west EG	37.2	D1 west 4.OG	51.4	F2 east 4.OG	51.1	M3 east 4.OG	49.7
B3 east 1.OG	59	D1 west 5.OG	52.9	F2 east 5.OG	51.3	M3 east 5.OG	50
B3 east 2.OG	58.8	D1 west 6.OG	53.6	F2 east 6.OG	51.4	M3 east 6.OG	50.2
B3 east 3.OG	58.5	D1 west 7.OG	54	F2 east 7.OG	51.5	M3 east 7.OG	50.3
B3 east 4.OG	58	D1 west 8.OG	54.2	F2 east 8.OG	51.5	M3 east 8.OG	50.4
B3 east 5.OG	57.5	D1 west 9.OG	54.4	F2 east 9.OG	51.7	M3 east 9.OG	50.7
B3 east 6.OG	56.9	D1 west EG	44.9	F2 east EG	42.1	M3 east EG	37
B3 east 7.OG	56.3	D2 east 1.OG	41.5	F2 west 1.OG	49.9		
B3 east 8.OG	55.7	D2 east 2.OG	43.1	F2 west 2.OG	51		
B3 east 9.OG	55.2	D2 east 3.OG	45.3	F2 west 3.OG	52.3		

B3 east EG	58.9	D2 east 4.OG	45.9	F2 west 4.OG	53.2		
B3 west 1.OG	41.7	D2 east 5.OG	46.3	F2 west 5.OG	54		
B3 west 2.OG	44.5	D2 east 6.OG	46.5	F2 west 6.OG	54.6		
B3 west 3.OG	47.3	D2 east 7.OG	46.7	F2 west 7.OG	54.9		
B3 west 4.OG	48	D2 east 8.OG	46.9	F2 west 8.OG	55.1		
B3 west 5.OG	48.5	D2 east 9.OG	47.8	F2 west 9.OG	55.3		
B3 west 6.OG	48.8	D2 east EG	38.9	F2 west EG	48.4		
B3 west 7.OG	49.3	D2 west 1.OG	44.9	H rooftop	49.5		
B3 west 8.OG	50.1	D2 west 2.OG	46.7	H rooftop	49.5		
B3 west 9.OG	51.5	D2 west 3.OG	50	H1 east 1.OG	44.3		
B3 west EG	37.2	D2 west 4.OG	51	H1 east 2.OG	46.3		
B4 west 1.OG	42.7	D2 west 5.OG	52.5	H1 east 3.OG	48.7		
B4 west 2.OG	45.4	D2 west 6.OG	53.4	H1 east EG	41.4		
B4 west 3.OG	47.7	D2 west 7.OG	53.9	H2 east	43		
B4 west 4.OG	48.8	D2 west 8.OG	54.1	H3 east 1.OG	47.7		
B4 west 5.OG	49.2	D2 west 9.OG	54.3	H3 east 2.OG	49.5		
B4 west 6.OG	49.5	D2 west EG	43	H3 east 3.OG	51.3		
B4 west 7.OG	49.9	D3 east 1.OG	41.6	H3 east EG	43.5		
B4 west 8.OG	50.7	D3 east 2.OG	43.3	J1 east 1.OG	47.9		
B4 west 9.OG	51.9	D3 east 3.OG	45.2	J1 east 2.OG	50		
B4 west EG	38.9	D3 east 4.OG	45.9	J1 east 3.OG	51.6		
B5 west 1.OG	42	D3 east 5.OG	46.3	J1 east 4.OG	52.4		
B5 west 2.OG	45.3	D3 east 6.OG	46.5	J1 east EG	45.7		
B5 west 3.OG	47.3	D3 east 7.OG	46.7	J2 east 1.OG	48.5		
B5 west 4.OG	48.5	D3 east 8.OG	46.9	J2 east 2.OG	50.5		
B5 west 5.OG	49	D3 east 9.OG	47.7	J2 east 3.OG	51.8		
B5 west 6.OG	49.4	D3 east EG	38.9	J2 east 4.OG	52.5		
B5 west 7.OG	49.9	D3 west 1.OG	44.7	J2 east EG	46.3		
B5 west 8.OG	51.4	D3 west 2.OG	47.7	J1 north 1.OG	51		
B5 west 9.OG	52.4	D3 west 3.OG	49.7	J1 north 2.OG	51.2		
B5 west EG	35.9	D3 west 4.OG	51.1	J1 north 3.OG	52.2		
B6 west 1.OG	40.6	D3 west 5.OG	52.7	J1 north 4.OG	53.2		
B6 west 2.OG	45.8	D3 west 6.OG	53.6	J1 north EG	50.7		
B6 west 3.OG	47.7	D3 west 7.OG	54	K rooftop	49.3		
B6 west 4.OG	48.7	D3 west 8.OG	54.3	K1 east 1.OG	49		
B6 west 5.OG	49.2	D3 west 9.OG	54.5	K1 east 2.OG	50.9		

B6 west 6.OG	49.7	D3 west EG	41.5	K1 east 3.OG	52.1		
B6 west 7.OG	50.6	D4 east 1.OG	41.7	K1 east 4.OG	52.6		
B6 west 8.OG	51.3	D4 east 2.OG	43.4	K1 east 5.OG	53.3		
B6 west 9.OG	52.7	D4 east 3.OG	45.2	K1 east 6.OG	53.4		
B6 west EG	33.9	D4 east 4.OG	45.9	K1 east 7.OG	53.6		
B7 west 1.OG	44	D4 east 5.OG	46.3	K1 east 8.OG	53.7		
B7 west EG	40.3	D4 east 6.OG	46.5	K1 east 9.OG	53.8		
C rooftop	48.2	D4 east 7.OG	46.7	K1 east EG	46.7		
C rooftop	48.7	D4 east 8.OG	47	K2 east 1.OG	50.3		
C1 west 1.OG	45.4	D4 east 9.OG	47.6	K2 east 2.OG	52		
C1 west 2.OG	47.3	D4 east EG	39	K2 east 3.OG	52.9		
C1 west 3.OG	48.8	D5 east 1.OG	41.8	K2 east 4.OG	53.3		
C1 west 4.OG	49.8	D5 east 2.OG	43.6	K2 east 5.OG	53.5		
C1 west 5.OG	50.4	D5 east 3.OG	45.4	K2 east 6.OG	53.6		
C1 west 6.OG	51	D5 east 4.OG	46.2	K2 east 7.OG	53.6		
C1 west 7.OG	51.6	D5 east 5.OG	46.5	K2 east 8.OG	53.6		
C1 west 8.OG	52.4	D5 east 6.OG	46.7	K2 east 9.OG	53.6		
C1 west 9.OG	53.3	D5 east 7.OG	47	K2 east EG	48.3		
C1 west EG	41.1	D5 east 8.OG	47.2	K1 south 1.OG	55.2		
C2 west 1.OG	45.6	D5 east 9.OG	47.8	K1 south 10.OG	59.7		
C2 west 2.OG	47.6	D5 east EG	39.2	K1 south 2.OG	58.1		
C2 west 3.OG	49.2	E1 east 1.OG	41.9	K1 south 3.OG	59		
C2 west 4.OG	50	E1 east 2.OG	43.8	K1 south 4.OG	59.4		
C2 west 5.OG	50.6	E1 east 3.OG	45.5	K1 south 5.OG	59.6		
C2 west 6.OG	51	E1 east 4.OG	46.2	K1 south 6.OG	59.7		
C2 west 7.OG	51.3	E1 east 5.OG	46.6	K1 south 7.OG	59.7		
C2 west 8.OG	52.1	E1 east 6.OG	46.9	K1 south 8.OG	59.7		
C2 west 9.OG	52.6	E1 east EG	39.1	K1 south 9.OG	59.7		
C2 west EG	39.7	E2 east 1.OG	42	K1 south EG	49		
C3 west 1.OG	46	E2 east 2.OG	44.1	L1 east 1.OG	51.1		
C3 west 2.OG	47.9	E2 east 3.OG	45.6	L1 east 2.OG	52.6		
C3 west 3.OG	49.5	E2 east 4.OG	46.4	L1 east 3.OG	53.4		
C3 west 4.OG	50.4	E2 east 5.OG	46.7	L1 east 4.OG	53.8		
C3 west 5.OG	50.9	E2 east 6.OG	47	L1 east 5.OG	53.9		
C3 west 6.OG	51.2	E2 east EG	39.1	L1 east 6.OG	54		
C3 west 7.OG	51.5	E3 east 1.OG	41.8	L1 east 7.OG	54		

C3 west 8.OG	52.1	E3 east 2.OG	44	L1 east 8.OG	54		
C3 west 9.OG	52.4	E3 east 3.OG	45.5	L1 east 9.OG	54		
C3 west EG	37.5	E3 east 4.OG	46.2	L1 east EG	49.4		
C4 west 1.OG	47.7	E3 east 5.OG	46.5	L2 east 1.OG	51.8		
C4 west 2.OG	50	E3 east 6.OG	46.8	L2 east 2.OG	54.9		
C4 west 3.OG	51.4	E3 east EG	38.9	L2 east 3.OG	55.8		
C4 west 4.OG	52.1	E4 east 1.OG	37.7	L2 east 4.OG	56		
C4 west 5.OG	52.5	E4 east 2.OG	39.7	L2 east 5.OG	56.1		
C4 west 6.OG	52.7	E4 east 3.OG	41.1	L2 east 6.OG	56.1		
C4 west 7.OG	52.9	E4 east 4.OG	42.1	L2 east 7.OG	56.1		
C4 west 8.OG	53.1	E4 east 5.OG	42.4	L2 east 8.OG	56.1		
C4 west 9.OG	53.4	E4 east 6.OG	42.7	L2 east 9.OG	56.1		
C4 west EG	42.3	E4 east EG	35.5	L2 east EG	44.2		

Winter Gardens/ Loggias

Winter gardens are proposed for Building O and loggias are proposed for building A / G / H, east façade of buildings B and C and west façade of building M+N. It is assumed that winter gardens comprise a fully single glazed façade and that loggias are balconies inset within the façade. The levels at the loggias are equivalent to the façade levels as given in Table 3.

Table 3 Noise levels incident on loggias and winter balconies	
Location	Highest façade noise level / dBA
Building A – east facade	59
Building B – east facade	67
Building C – east facade	60
Buildings G / H	54
Building M+N – west facade	64
Building O	64

Winter gardens and loggias provide screening that typically gives a reduction in noise level of -5 to -15 dB compared to the free-field levels. On this basis all proposed winter gardens and loggias are predicted to be exposed to noise levels below the ambient noise significance threshold.

Summary of External Ambient Noise Level Assessment

The results show that the noise levels in most of proposed balconies, podiums and roof terraces would fall below the adopted criteria for ambient noise levels in amenity areas. The ambient noise levels that exceed the criteria are summarised in Table 4 and described below.

Table 4 Exceedances of External Noise Levels at Balcony, Podiums, Rooftop Amenity Spaces	
Building	Location of exceedances
Building A	No exceedances
Building B	On balconies to the east of the building, which are areas that are near the Stone Foundries. No exceedances on podium level.
Building C	No exceedances

Building D, E, F, G, H, J	No exceedances
Building K+L	Some exceedances to the balconies to the south and east façade of the building, near Anchor and Hope Lane South of Bugsby's Way
Building M+N	No exceedances. Loggias to be incorporated to west façade
Building O	Exceedances to the external amenity space (communal balcony) overlooking Anchor and Hope Lane South of Bugsby's Way.

Whilst a percentage of 10 % of individual balconies, or roof terraces may experience ambient noise levels which exceed the ambient noise significance threshold, all residents of the amended proposed development would have access to a variety of external amenity spaces which would be exposed to noise levels below the significance threshold. Therefore, **no significant effects** are predicted as a result of ambient noise in external amenity areas.

1.6 Assessment: Internal Noise Levels

For the purpose of this assessment, the night-time noise levels have been used to assess compliance with BS 8233 criteria. This is because during the night-time, the noise from the industrial sources at the wharfs will be constant and the noise criteria for bedrooms is lower than during the daytime (30 dB vs 35 dB LAeq). As such, night time is considered to be the worst-case scenario and any mitigation required to achieve the night time noise criteria will, by default, also achieve the daytime noise level criteria.

Figures 8 to 11 show the predicted façade incident noise levels for the amended proposed development during night time, including contributions from all noise sources.

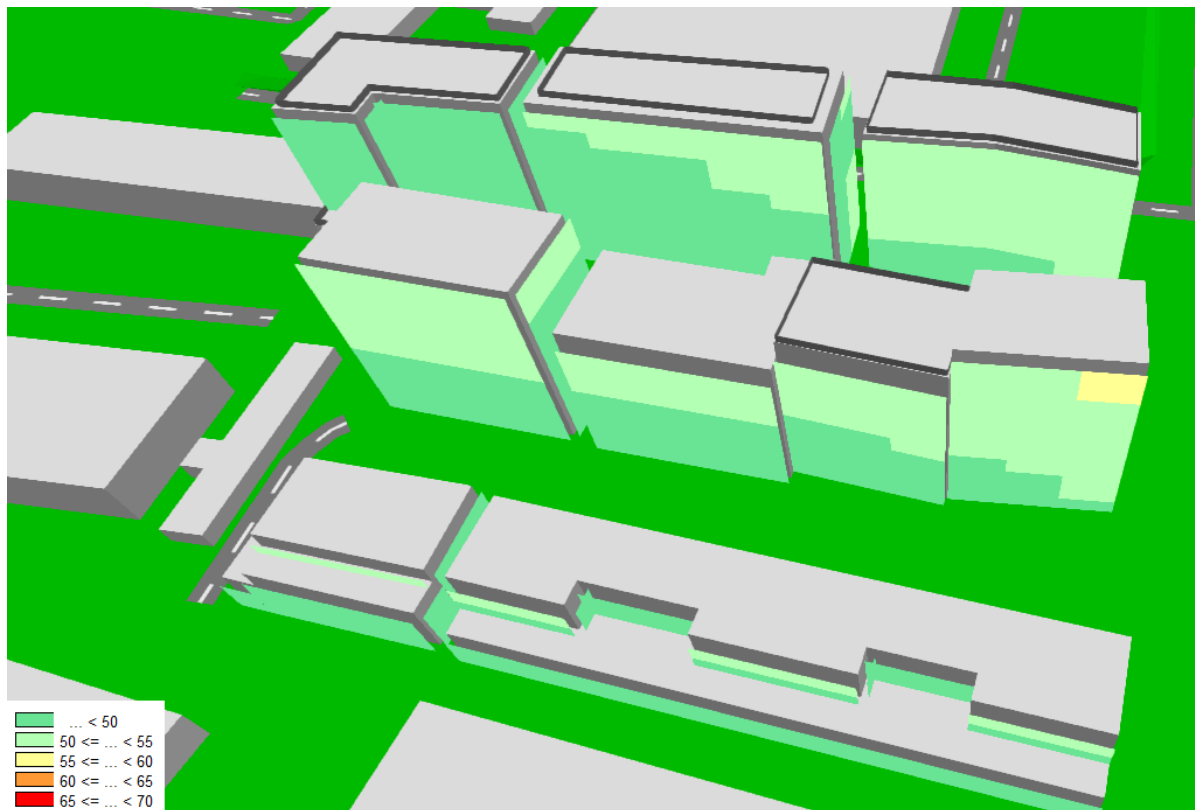

Figure 6: Predicted Façade Incident Noise Levels – Plot A – Southwest View

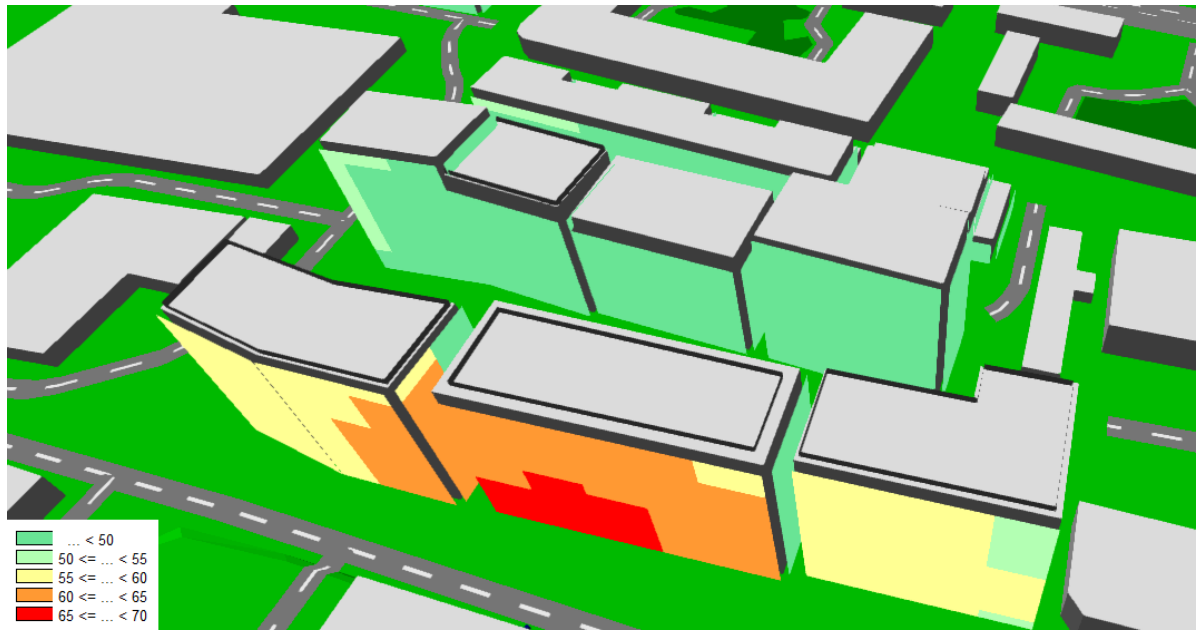

Figure 7: Predicted Façade Incident Noise Levels – Plot A – Northeast View

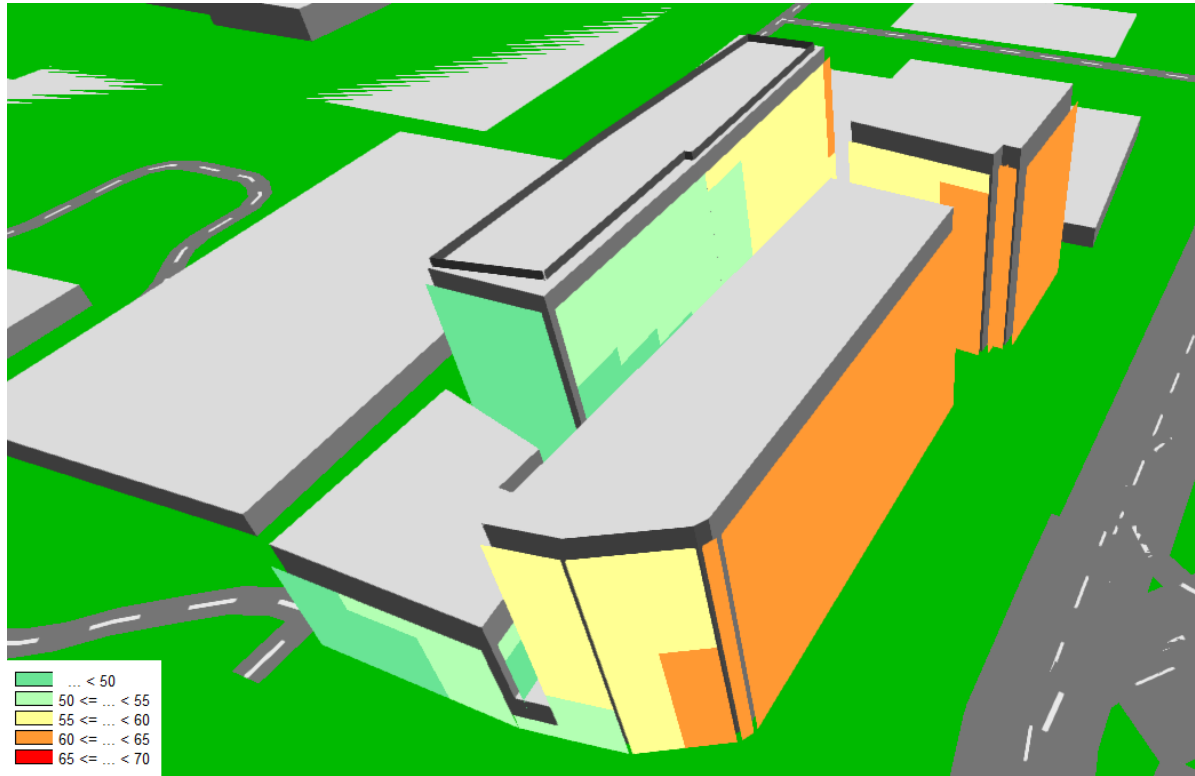

Figure 8: Predicted Façade Incident Noise Levels – Plot B – Northwest View

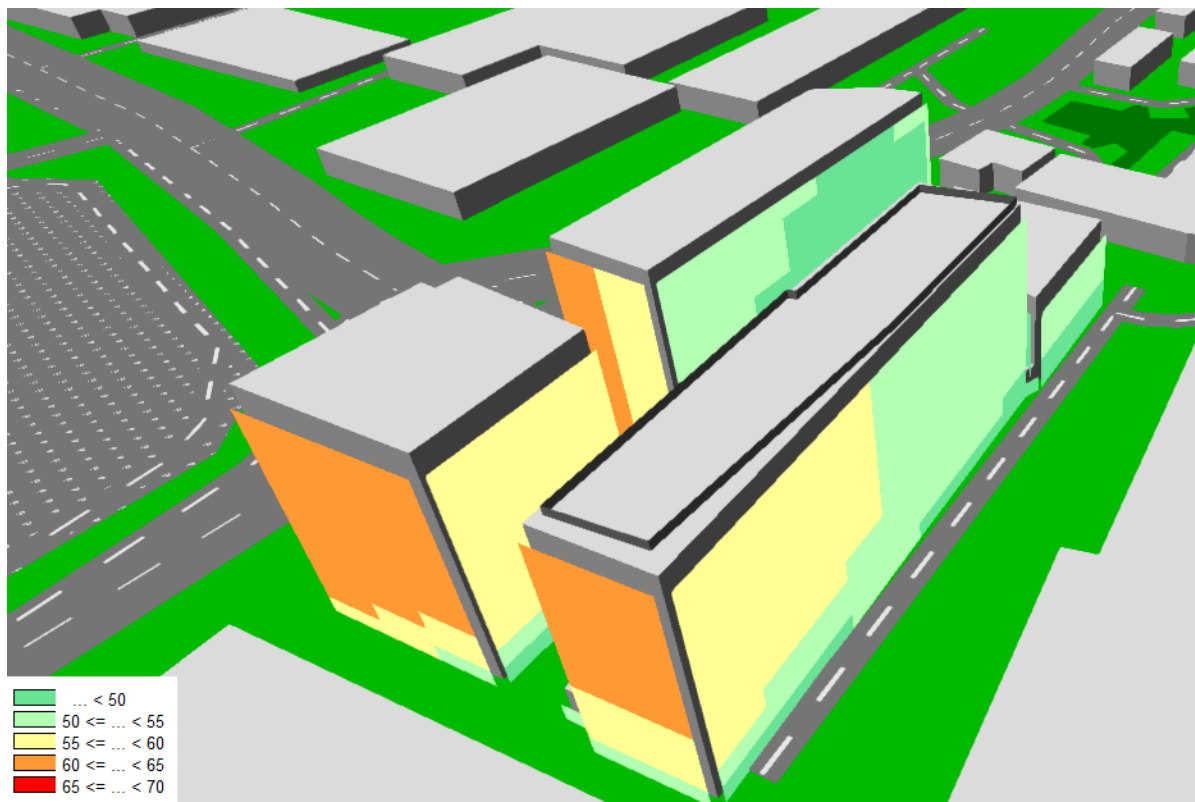

Figure 9: Predicted Façade Incident Noise Levels – Plot B – Southeast View

Tonal Noise Affecting the Proposed Development

Tonal noise levels from the dredgers have been calculated and the noise model shows that the worst case predicted Leq, 63 Hz noise level predicted across the amended proposed development is 69 dB Leq, 63 Hz at the top of building G. Mitigation for such exceedances is provided below.

1.7 Mitigation by Design: Façades

In order to achieve the required level of sound reduction for each façade, the ventilation strategy, glazing and cladding have been designed to achieve the appropriate minimum performance standards for internal noise levels and internal tonal noise.

Table 5 outlines the potential ventilation strategy and glazing performance standards which would be suitable to achieve the required level of attenuation. The specific design strategy for each element is subject to coordination with non-acoustic design elements which will be undertaken during the detailed design.

Table 5 Recommendations for sound insulation performance of building façade		
Required reduction in noise level (outside to inside)	Typical glazing sound insulation performance $R_w + C_{tr}$	Potential ventilation strategy
<20	27 dB	Standard trickle vents
20 – 30	27 - 37 dB	Acoustic trickle vents typically $D_{ne,w}$ 39-45 dB
30 – 40	35 - 45 dB	Mechanical whole-house ventilation

The external cladding and any internal wall linings will also be designed to ensure the glazing sound insulation is not undermined. This typically requires a sound insulation performance at least 10 dB better than the glazing sound insulation performance. The exact build-ups and products to be used to meet the acoustic criteria will be developed during the detailed design.

Based on the results of the modelling, and calculations of noise break-in to bedrooms, the appropriate façade design strategy has been applied to each elevation of the proposed development as shown in Figures 10 and 11. The mark ups are in accordance with the colours in Table 6 and the strategies apply to apartments at all levels, unless otherwise stated.



Figure 10: Sound Insulation Requirements for Plot A of the Site

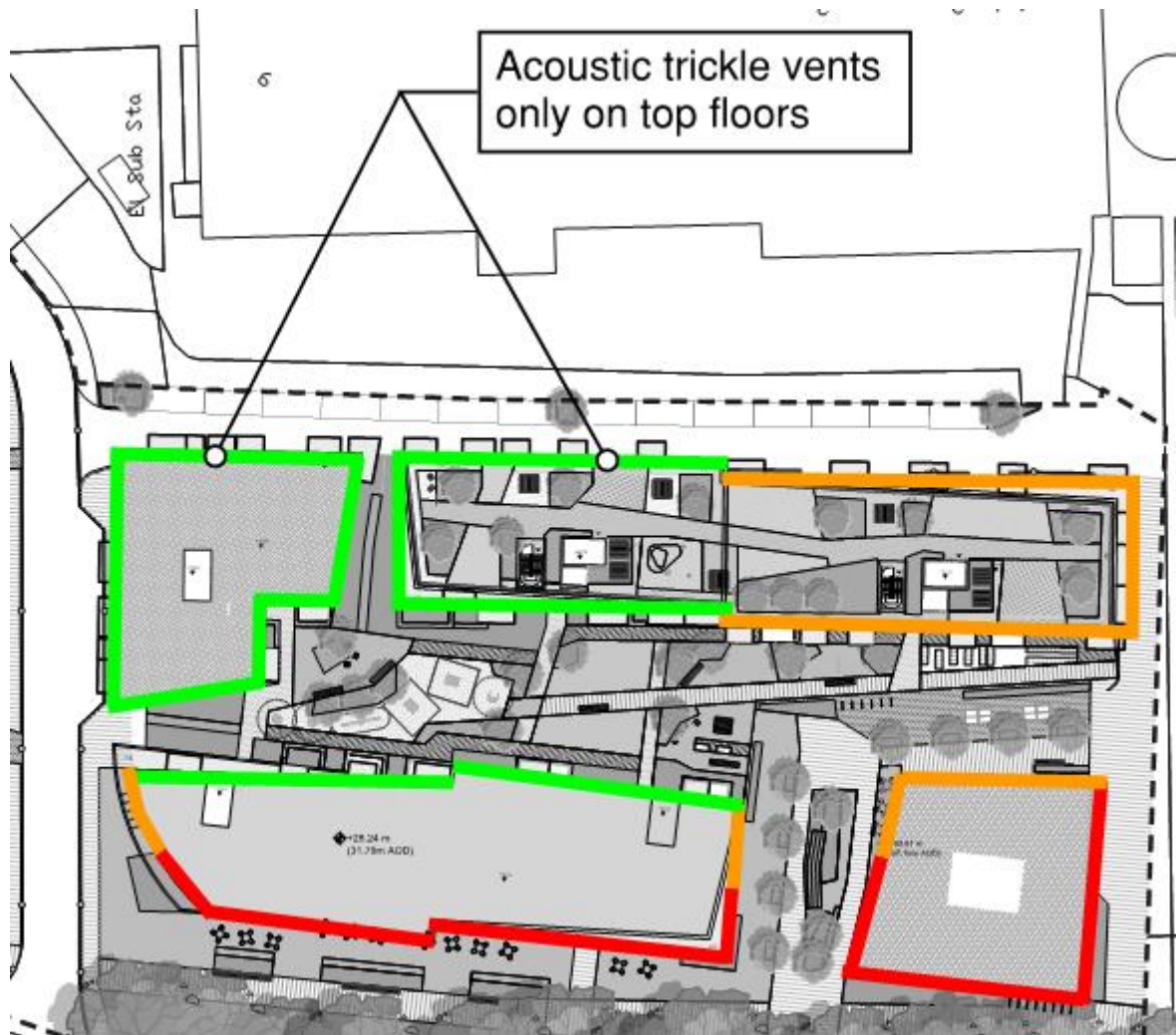

Figure 11 Sound Insulation Requirements for Plot B of the Site

With the application of a façade strategy similar to that shown in Figure 10 and 11, the internal ambient noise levels are predicted to fall below the adopted significance threshold. On this basis no significant effects are predicted in terms of internal noise levels within proposed dwellings.

Internal Tonal Noise Levels

In order for internal tonal noise levels from the dredgers to meet the adopted significance threshold of $Leq,63Hz(oct)$, it has been calculated that the façade of the amended proposed development would need to provide an outside to inside level difference of at least 30 dB at 63 Hz.

A range of glazing options exist which are capable of meeting both this tonal noise reduction requirement and the overall $Rw + Ctr$ requirements set out in Table 4. For example, acoustic laminate double glazing (8/20/12.8A) is capable of achieving $Rw + Ctr$ 37 dB and has an octave band sound reduction of 35 dB at 63Hz. With this glazing and an acoustic trickle vent rated $D_{ne,w}$ 43 dB that has an octave band sound reduction of 33 dB at 63Hz, the calculated internal noise level in the worst-affected bedroom during night time is 24 dB and 46 dB at 63 Hz, which are both below the significance threshold. These strategies are capable of being secured by planning condition.

With the adoption of appropriate glazing and ventilation strategies to be developed during the detailed design, the internal ambient and tonal noise levels are predicted to be below the adopted significance threshold; therefore, no significant effects are predicted.

APPENDICES 11.1-11.5A

Daylight, Sunlight, Overshadowing and Solar Glare Technical Appendices



Appendix 11.1A

Drawings showing the baseline and proposed development scenarios

Sources of information

Listed in Appendix 11.1

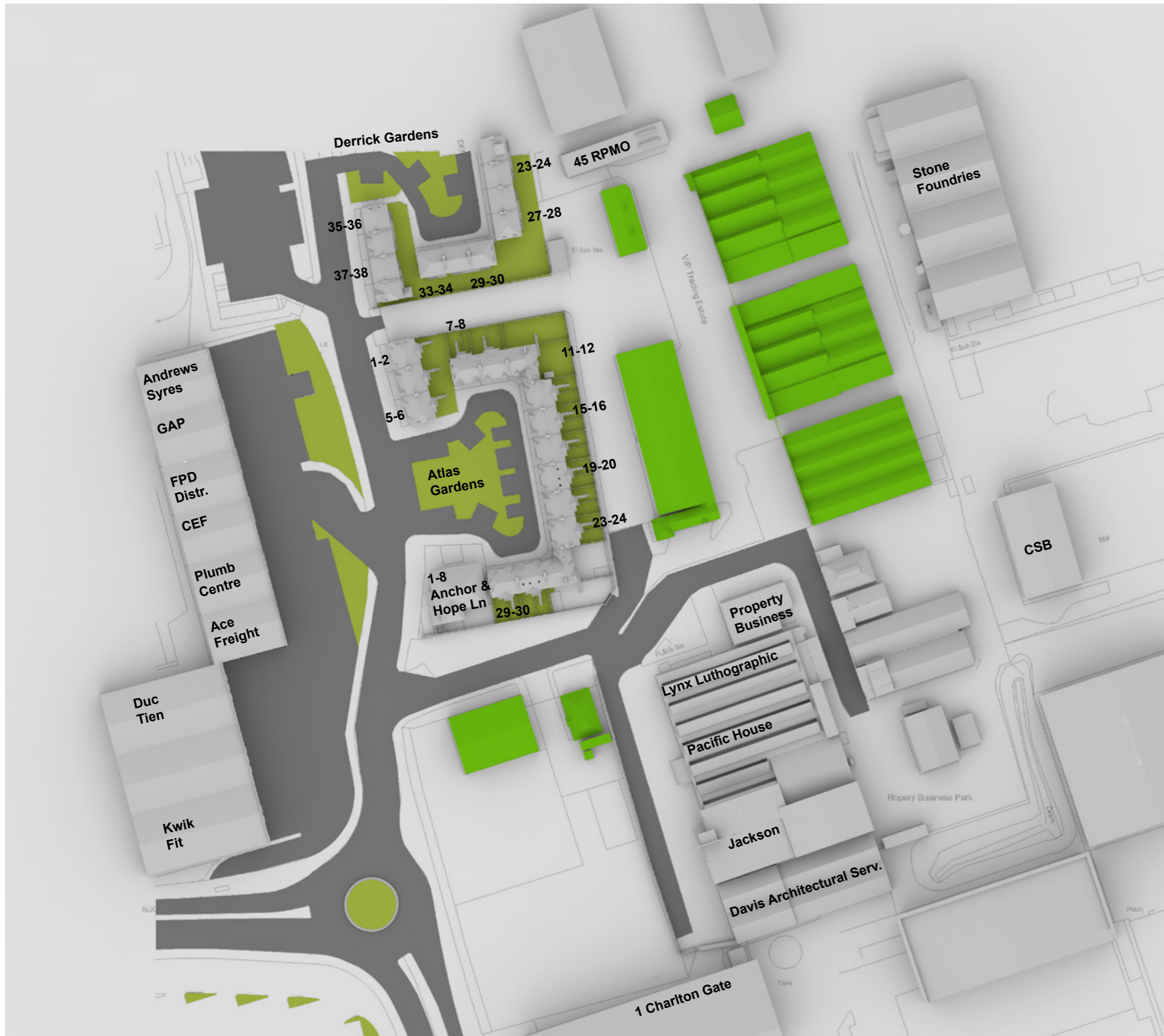

Key:

- Existing
- Proposed

NORTH



Project Charlton Riverside
 London
 SE7 7RY

Title Existing Condition
 Plan View

Drawn	YH	Checked	--
-------	----	---------	----

Date	27/11/2018	Rel no.	35
------	------------	---------	----

Drawing no. 1864-DS01-01

Sources of information

Listed in Appendix 11.1

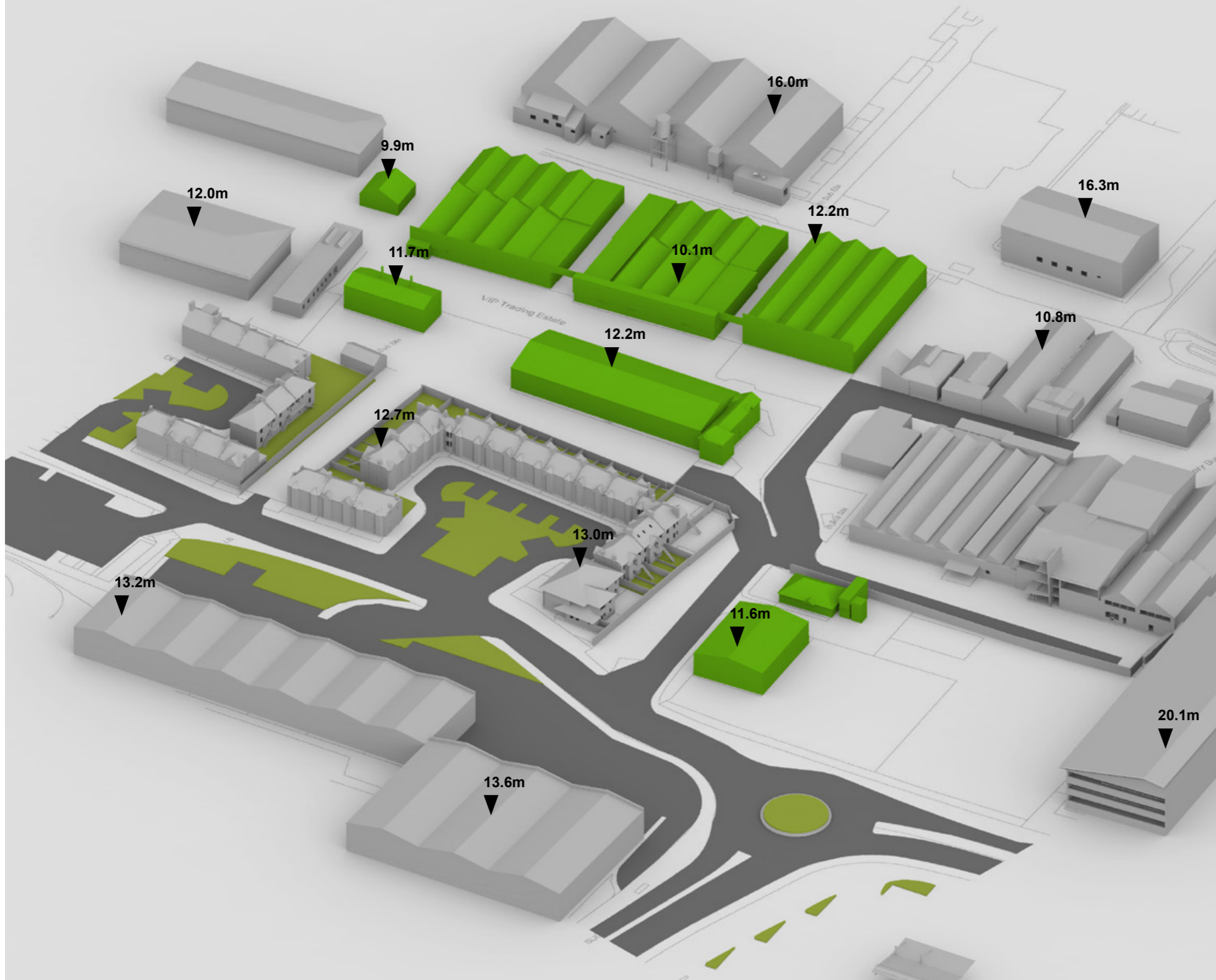

Key:

- Existing
- Proposed

Project Charlton Riverside
London
SE7 7RY

Title Existing Condition
3D View

Drawn YH Checked --

Date 27/11/2018 Rel no. 35

Drawing no. 1864-DS01-02

Sources of information

Listed in Appendix 11.1

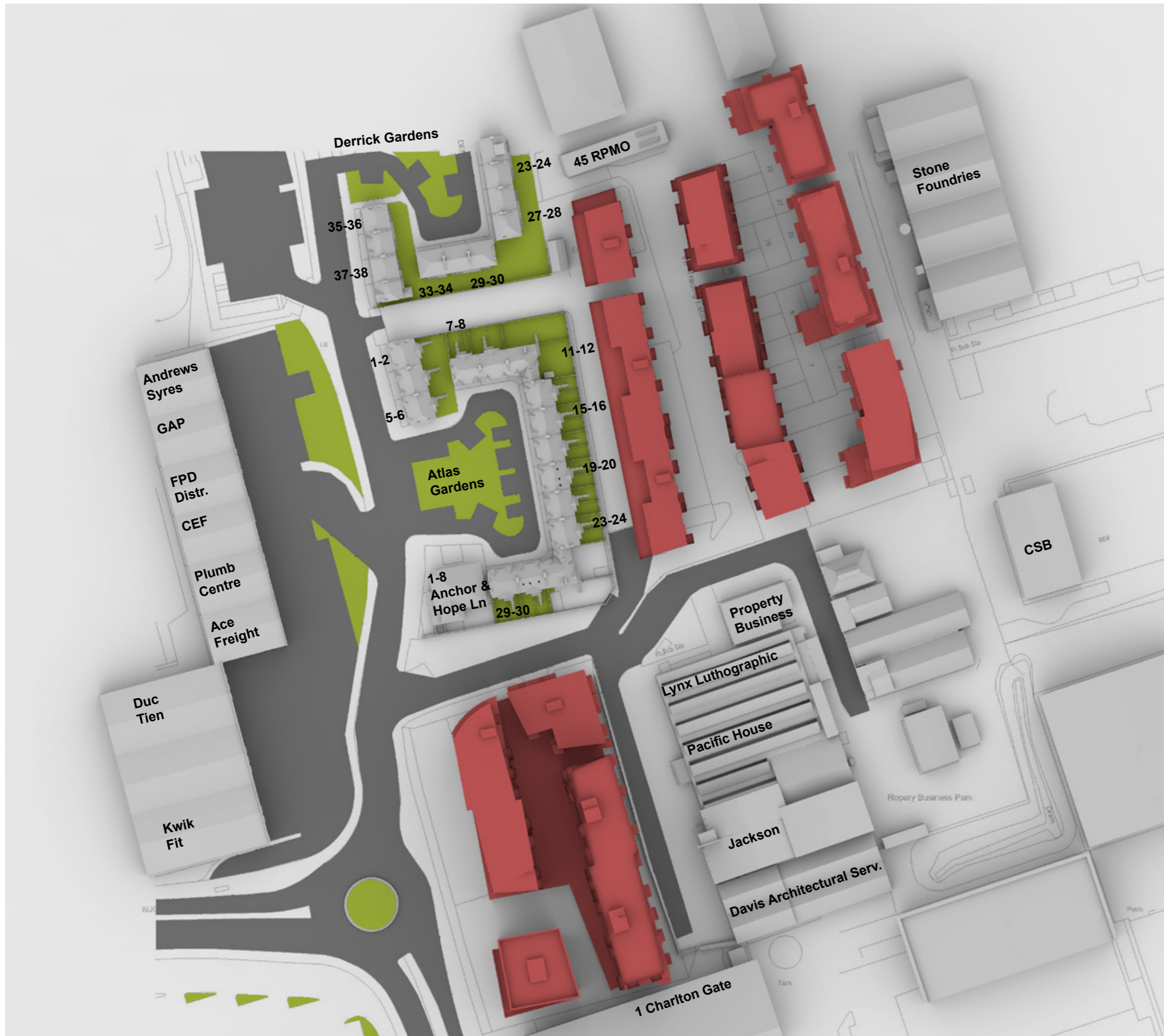

Key:

- Existing
- Proposed

NORTH



Project Charlton Riverside
 London
 SE7 7RY

Title Proposed Development
 Plan View

Drawn YH Checked --

Date 27/11/2018 Rel no. 35

Drawing no. 1864-DS01-03

Sources of information

Listed in Appendix 11.1

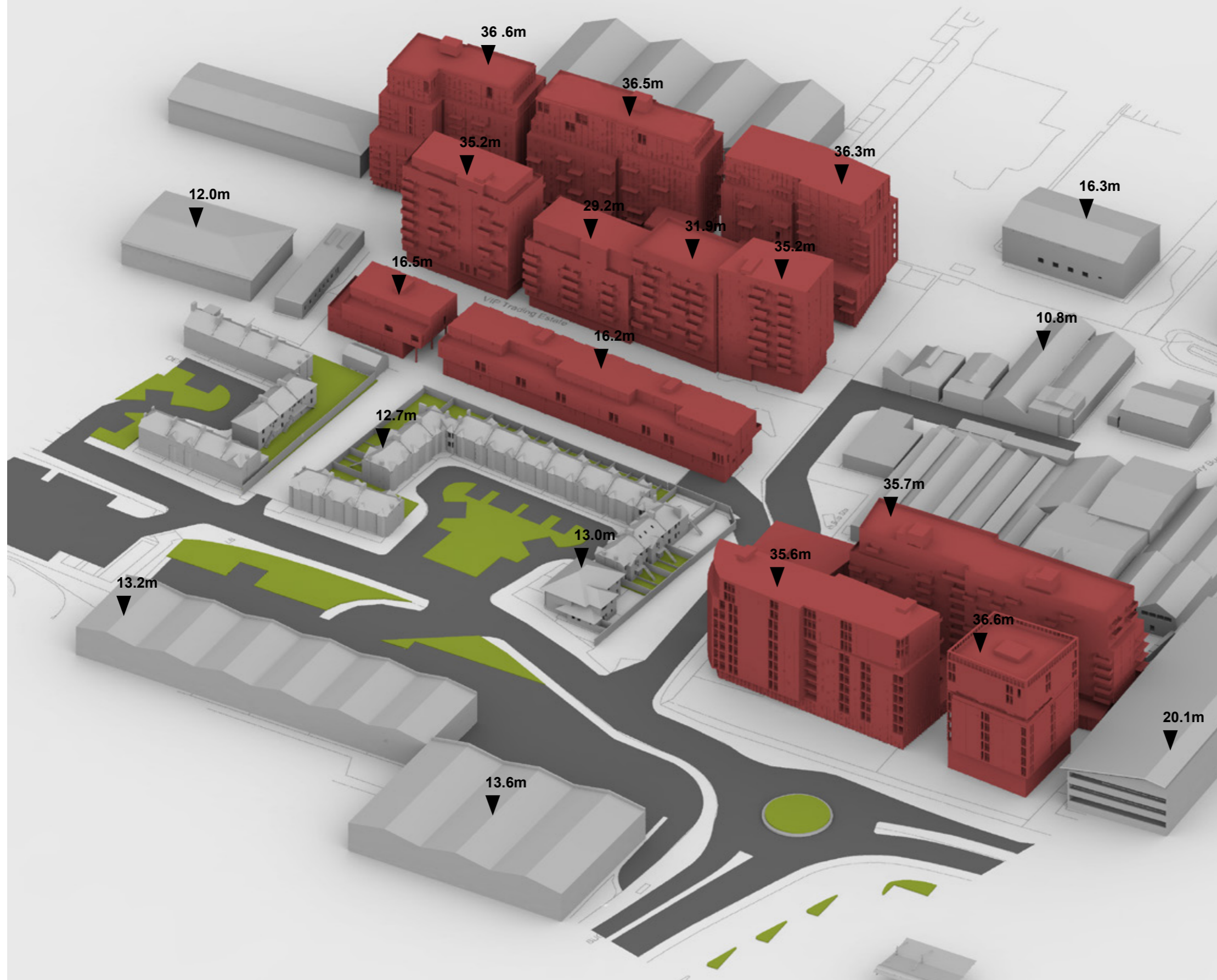

Key:

- Existing
- Proposed

Project Charlton Riverside
London
SE7 7RY

Title Proposed Development
3D View

Drawn YH Checked --

Date 27/11/2018 Rel no. 35

Drawing no. 1864-DS01-04

Sources of information

See Sources of information sheet in Appendix 11.1

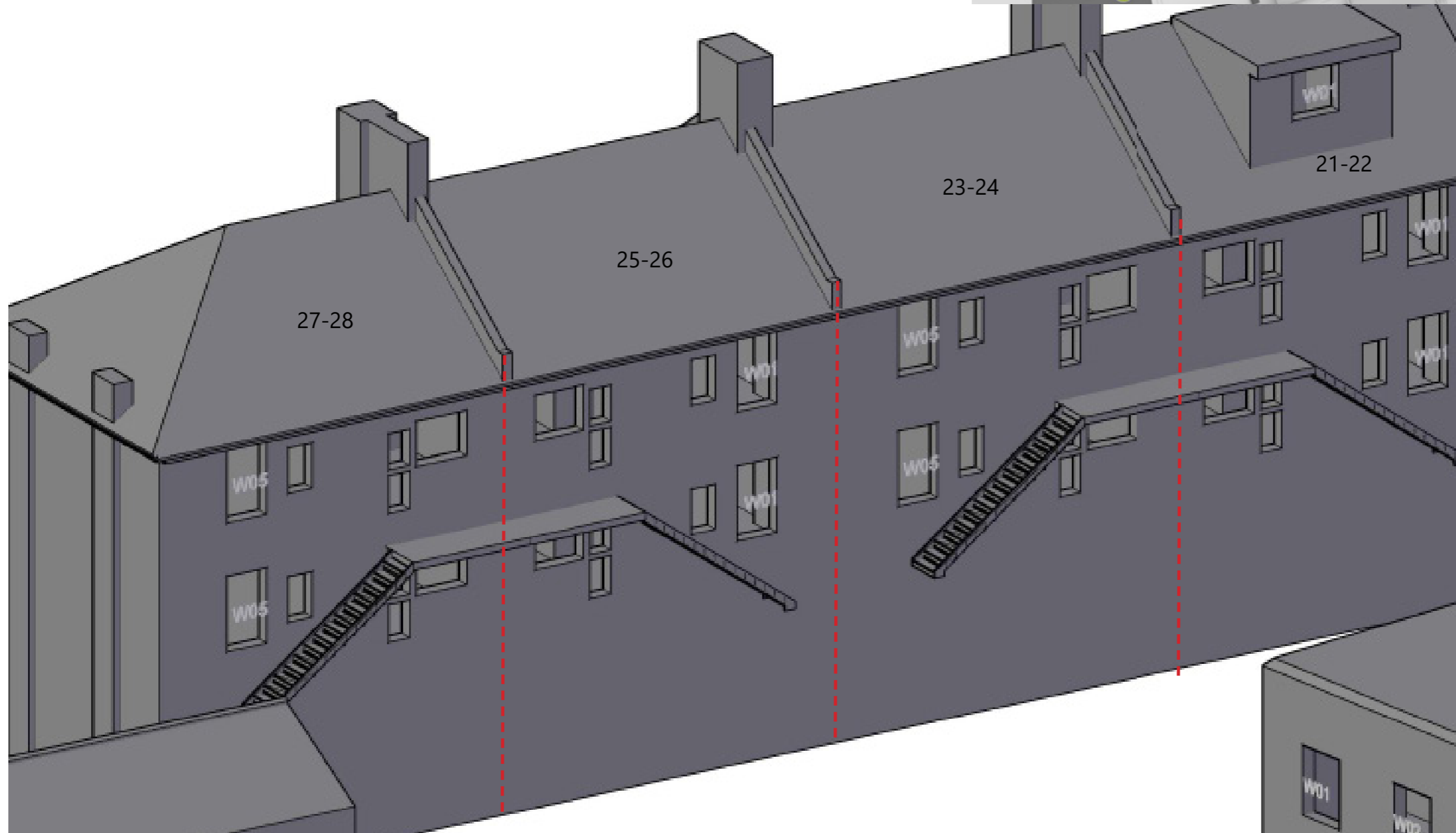
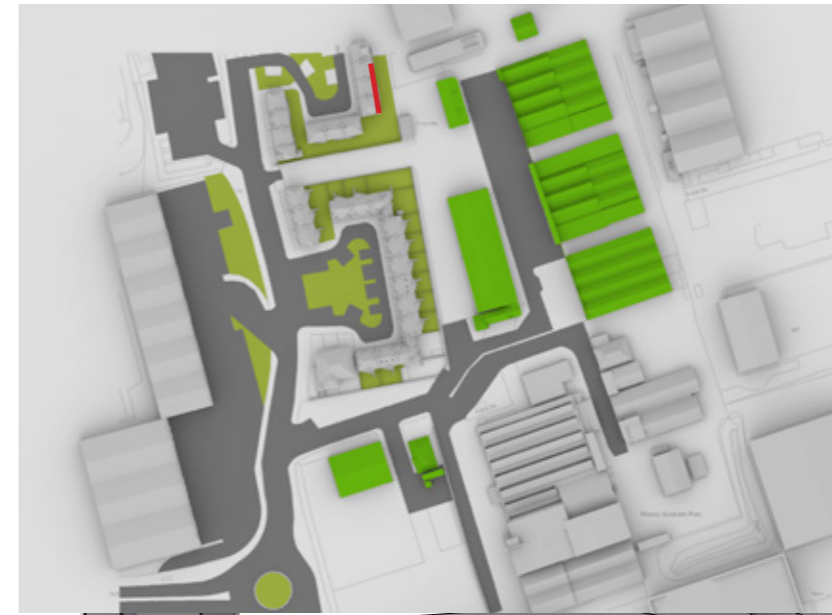

Project Charlton Riverside
Greenwich
London

Title 21-22, 23-24, 25-26,
27-28 Derrick Gardens
Window Map

Drawn AP Checked PS

Date 15/10/2018 Rel no. 34

Drawing no. 1864-WM09

Sources of information

See Sources of information sheet in Appendix 11.1

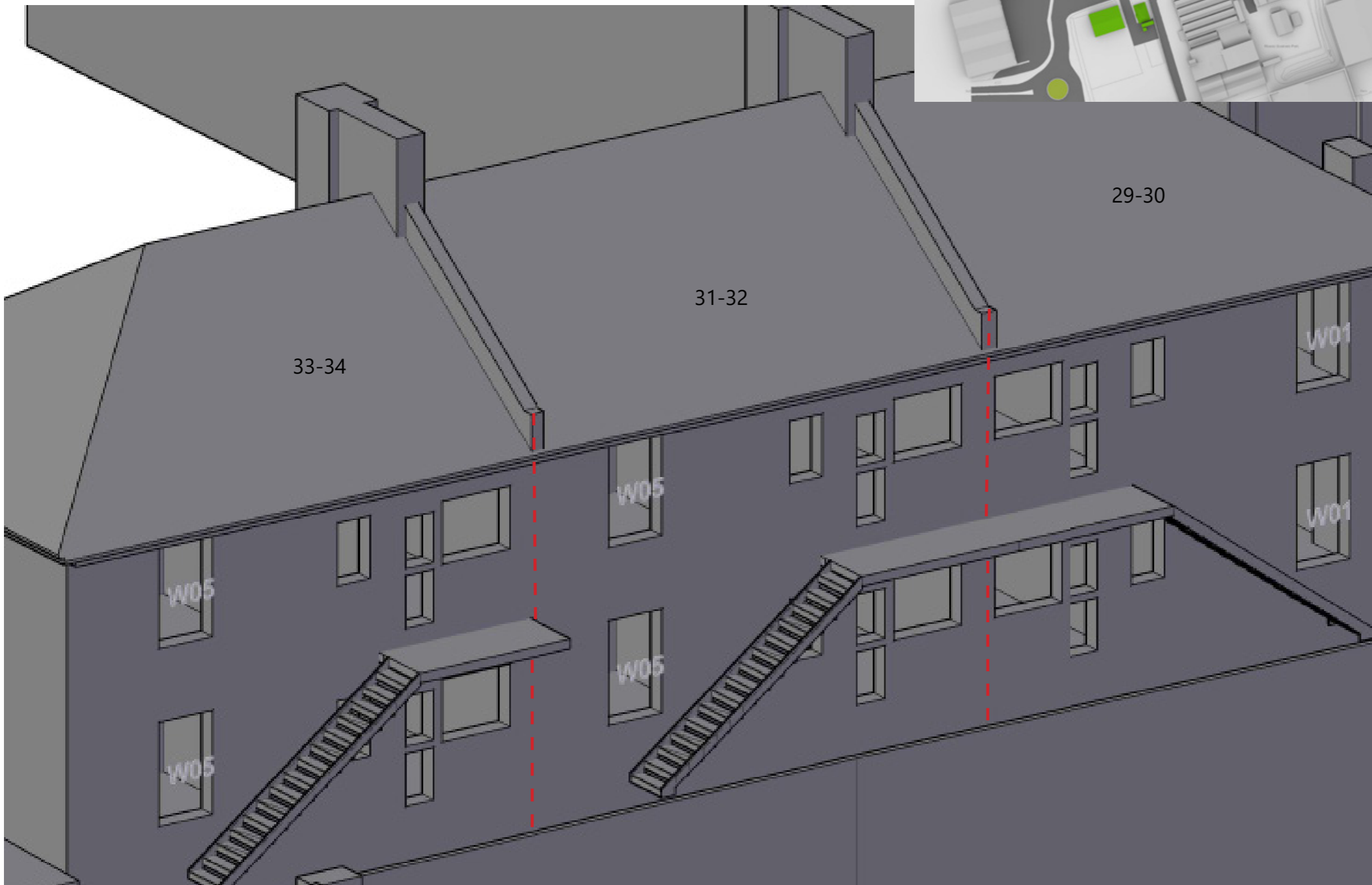
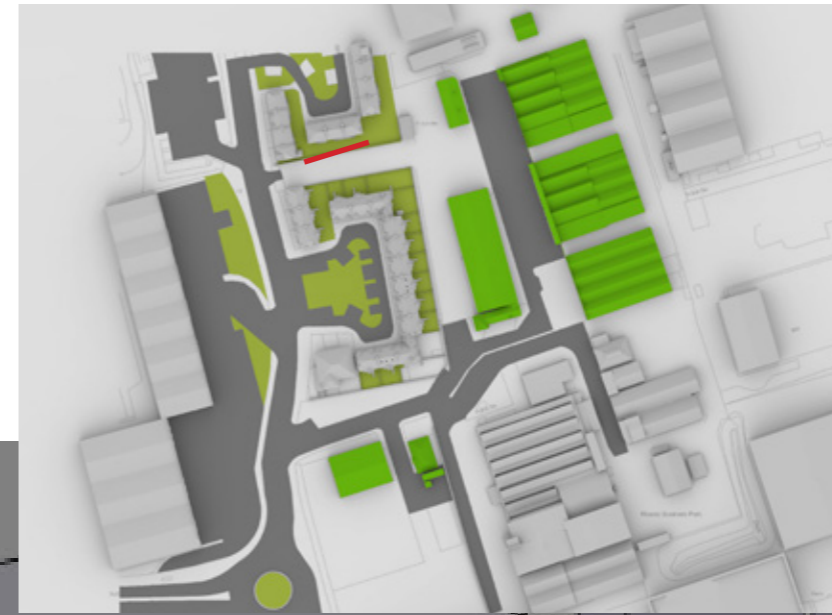

Project Charlton Riverside
Greenwich
London

Title 29-30, 31-32, 33-34 Derrick Gardens
Window Map

Drawn AP Checked PS

Date 15/10/2018 Rel no. 34

Drawing no. 1864-WM10

Sources of information

See Sources of information sheet in Appendix 11.1

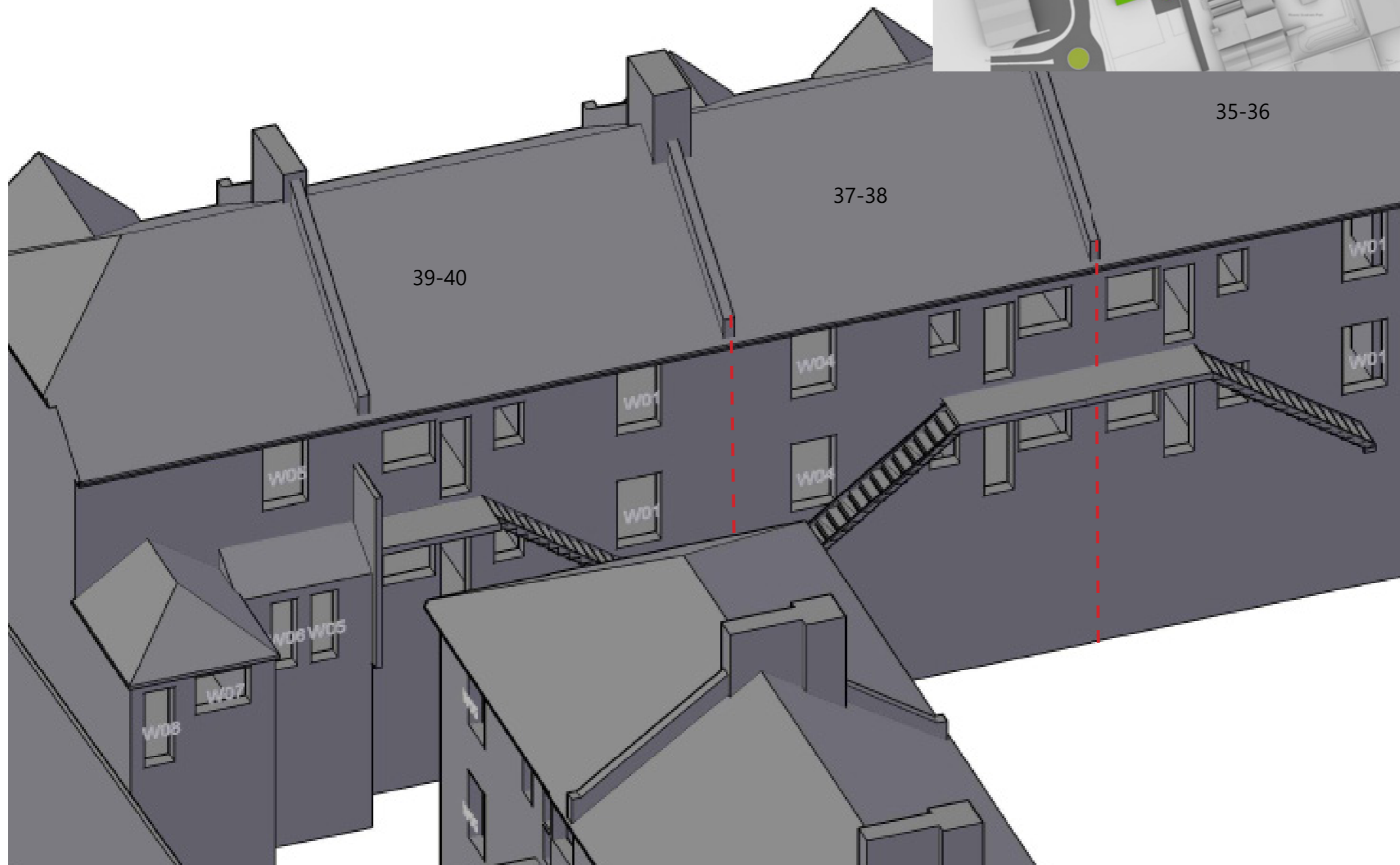
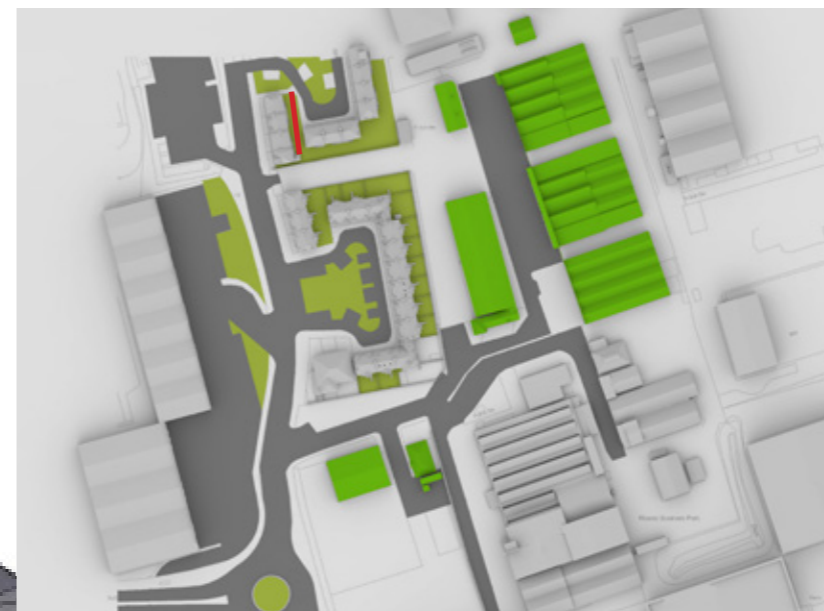

Project Charlton Riverside
Greenwich
London

Title 35-36, 37-38, 39-40 Derrick Gardens
Window Map

Drawn AP Checked PS

Date 15/10/2018 Rel no. 34

Drawing no. 1864-WM11

Sources of information

See Sources of information sheet in Appendix 11.1

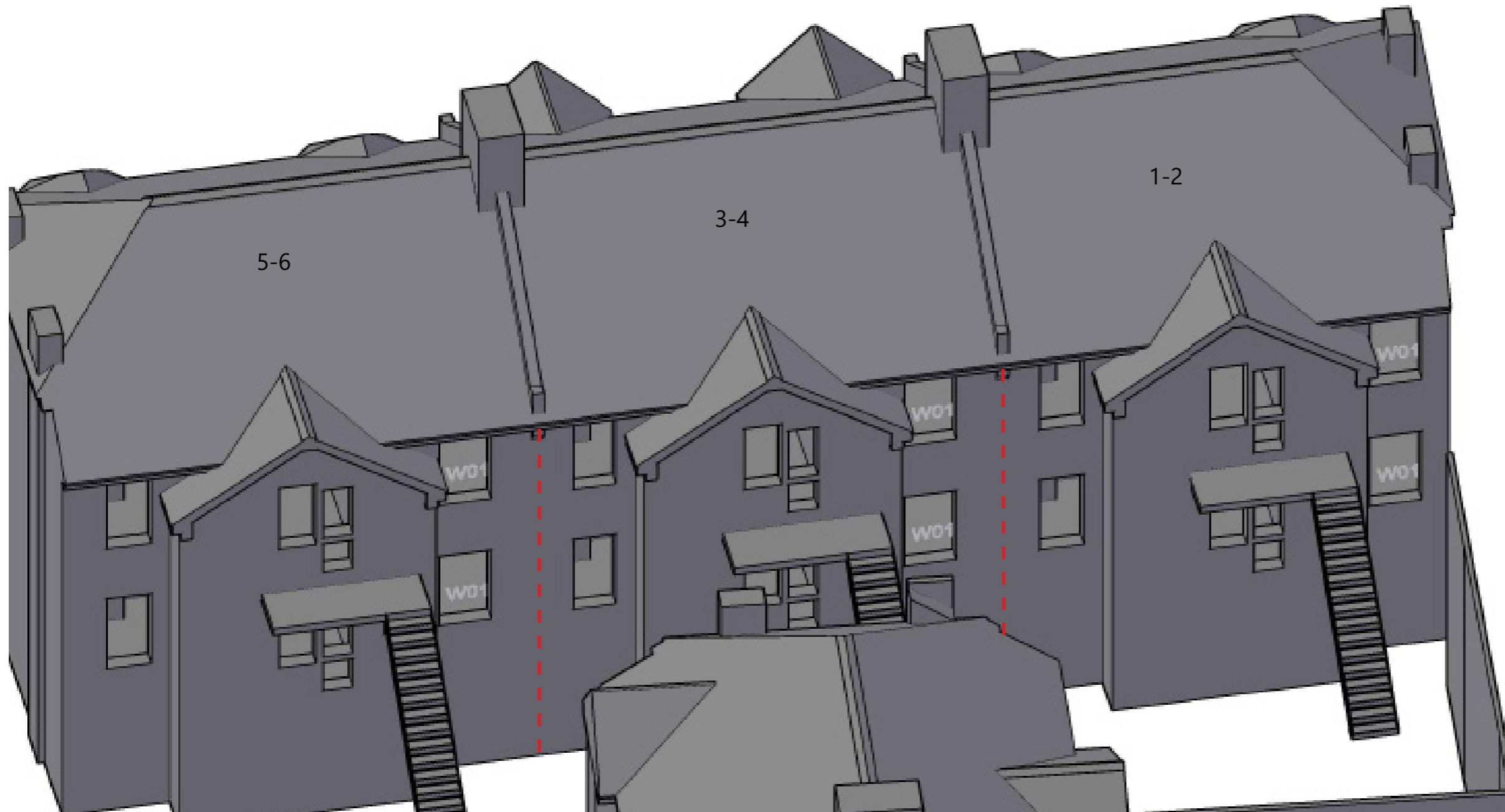
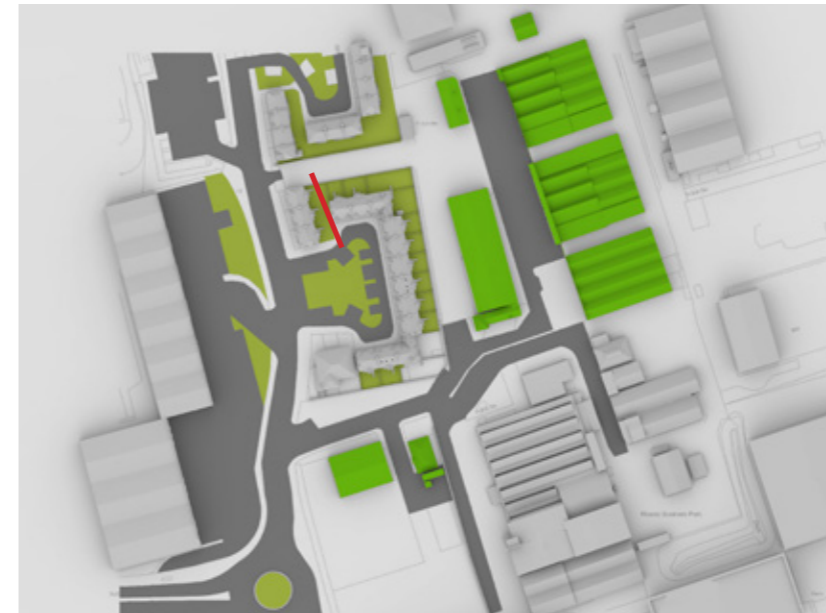

Project Charlton Riverside
Greenwich
London

Title 1-2, 3-4, 5-6 Atlas Gardens
Window Map

Drawn AP Checked PS

Date 15/10/2018 Rel no. 34

Drawing no. 1864-WM12

Sources of information

See Sources of information sheet in Appendix 11.1

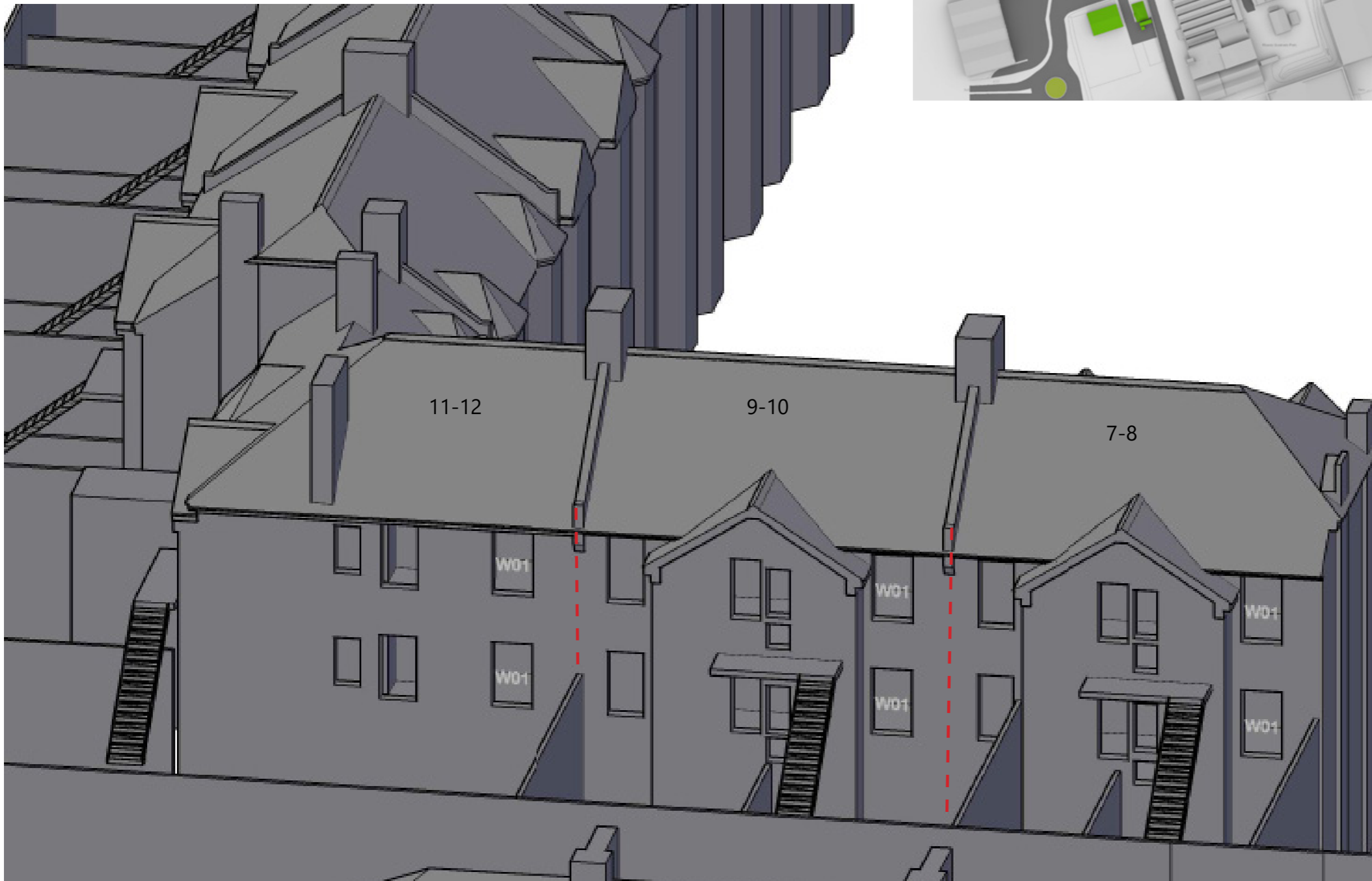
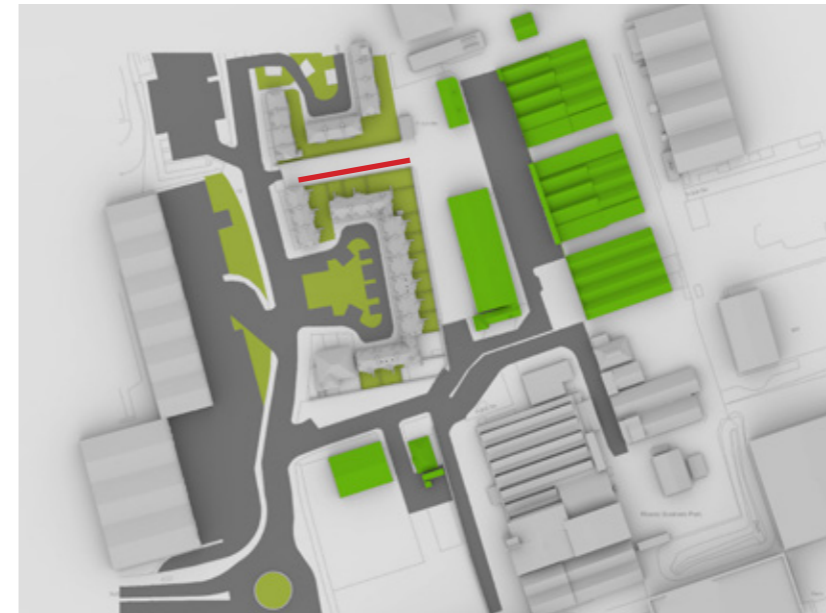

Project Charlton Riverside
Greenwich
London

Title 7-8, 9-10, 11-12 Atlas Gardens
Window Map

Drawn AP Checked PS

Date 15/10/2018 Rel no. 34

Drawing no. 1864-WM13

Sources of information

See Sources of information sheet in
Appendix 11.1

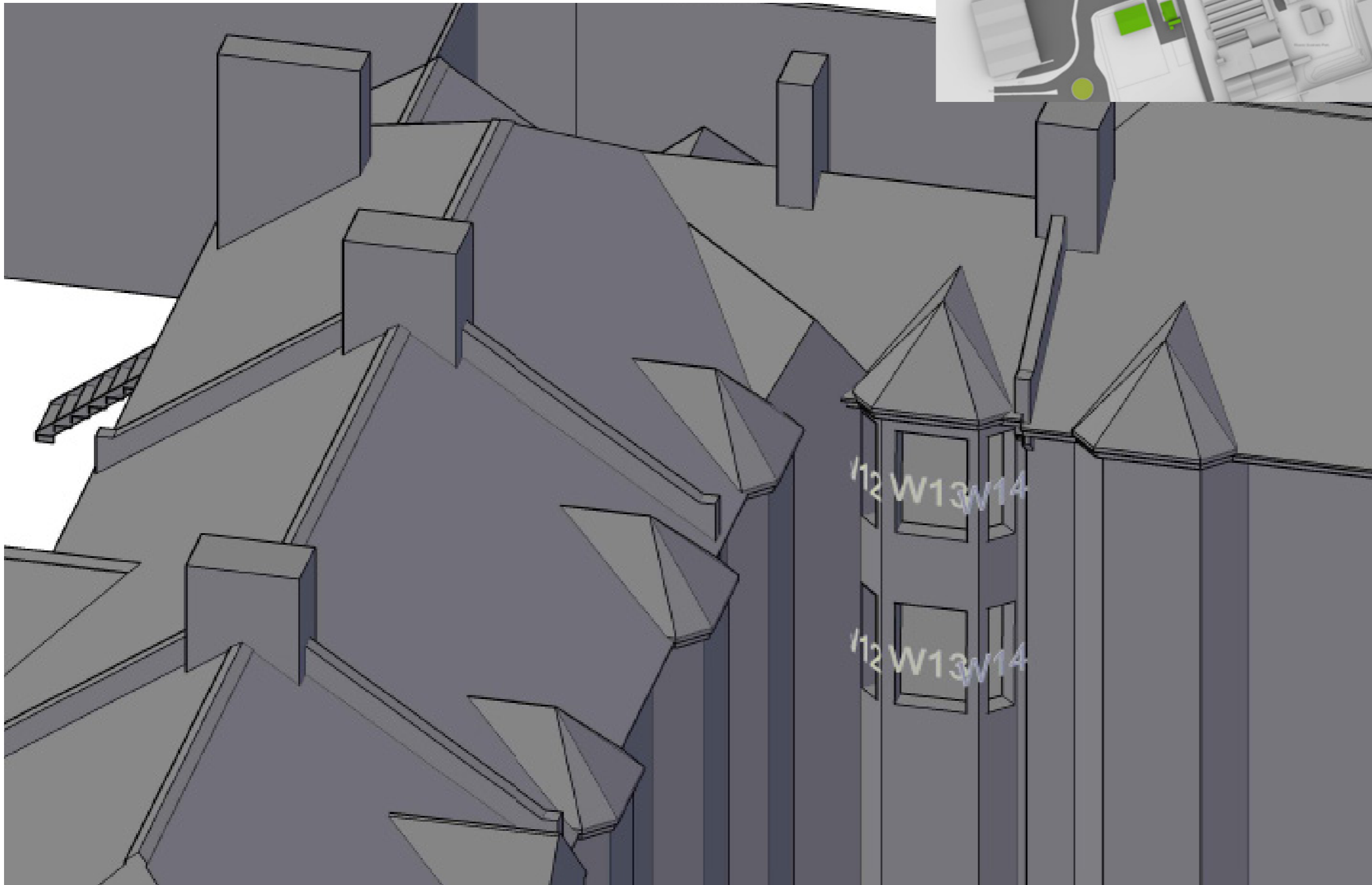
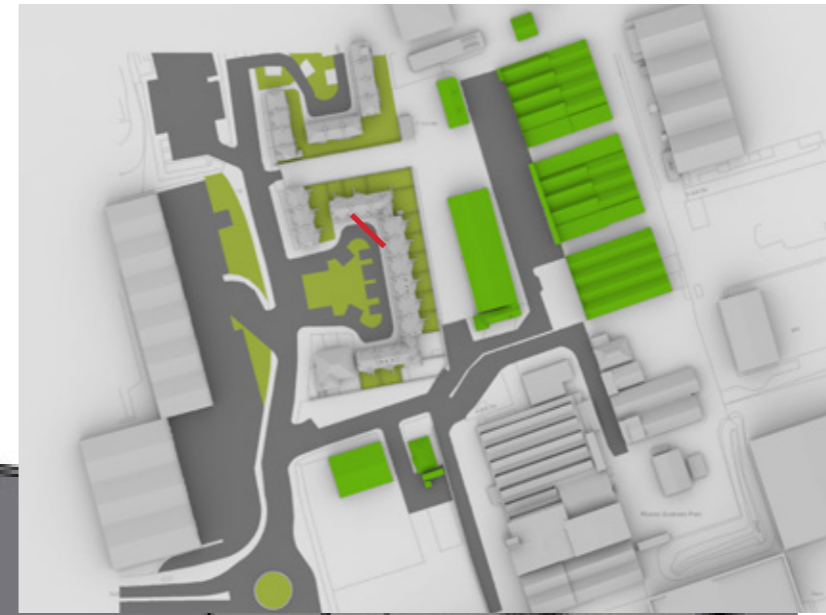

Project Charlton Riverside
Greenwich
London

Title 11-12 Atlas Gardens
(Rear view)
Window Map

Drawn AP Checked PS

Date 15/10/2018 Rel no. 34

Drawing no. 1864-WM14

Sources of information

See Sources of information sheet in Appendix 11.1

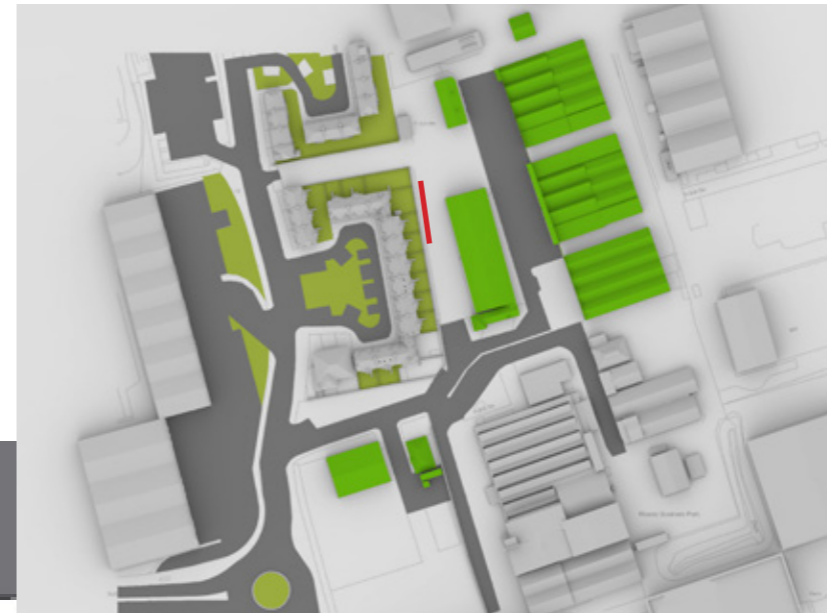

Project Charlton Riverside
Greenwich
London

Title 11-12, 13-14, 15-16 Atlas Gardens
Window Map

Drawn AP Checked PS

Date 15/10/2018 Rel no. 34

Drawing no. 1864-WM15

Sources of information

See Sources of information sheet in Appendix 11.1

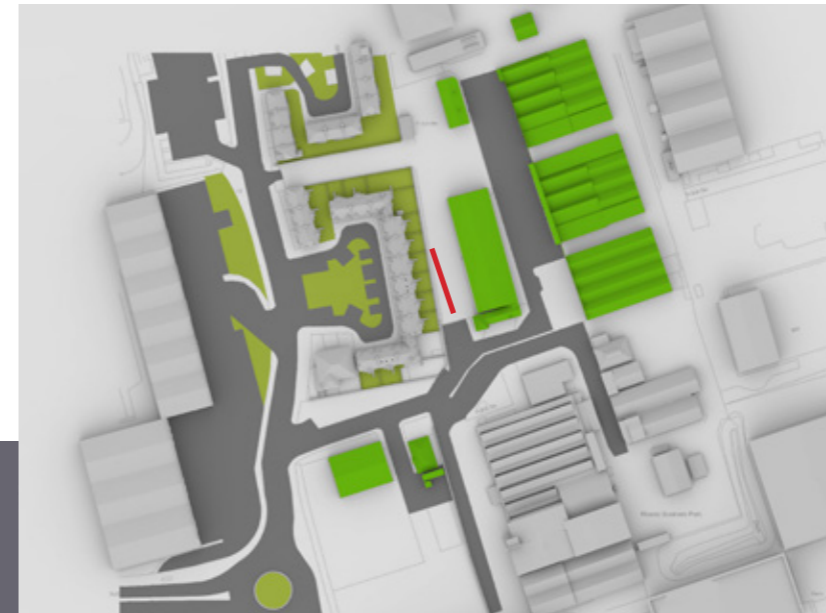

Project Charlton Riverside
Greenwich
London

Title 15-16, 17-18, 19-20 Atlas Gardens
Window Map

Drawn AP Checked PS

Date 15/10/2018 Rel no. 34

Drawing no. 1864-WM16

Sources of information

See Sources of information sheet in Appendix 11.1

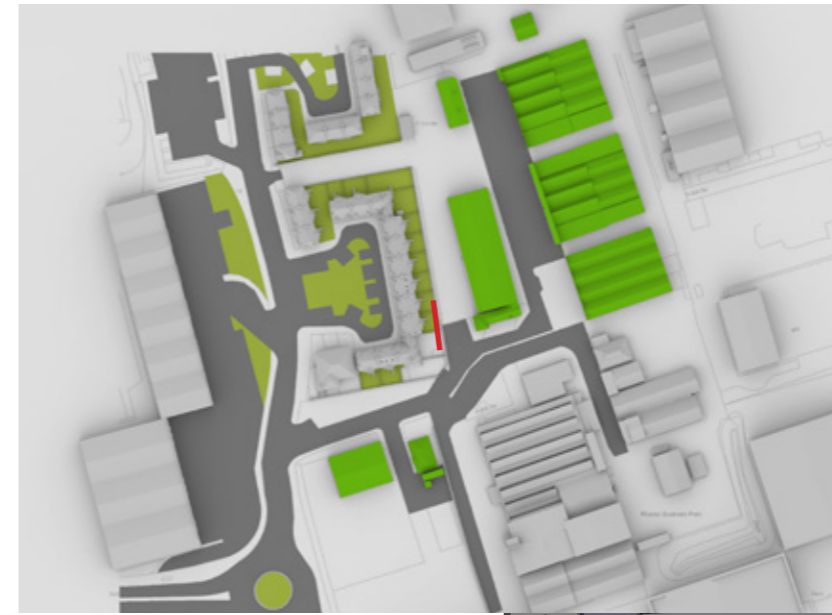

Project Charlton Riverside
Greenwich
London

Title 21-22, 23-24, 25-26 Atlas Gar-
dens
Window Map

Drawn AP Checked PS

Date 15/10/2018 Rel no. 34

Drawing no. 1864-WM17

Sources of information

See Sources of information sheet in Appendix 11.1

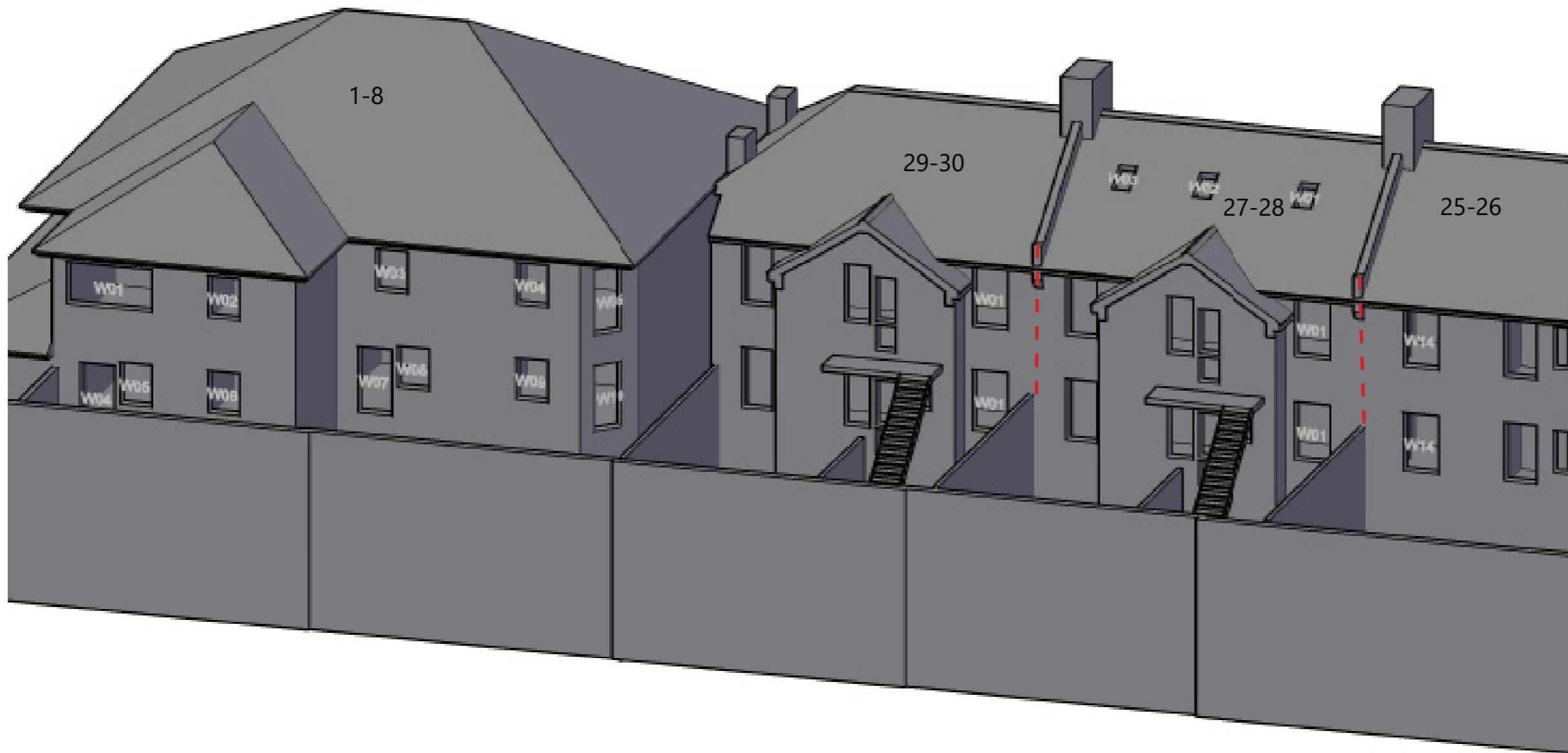
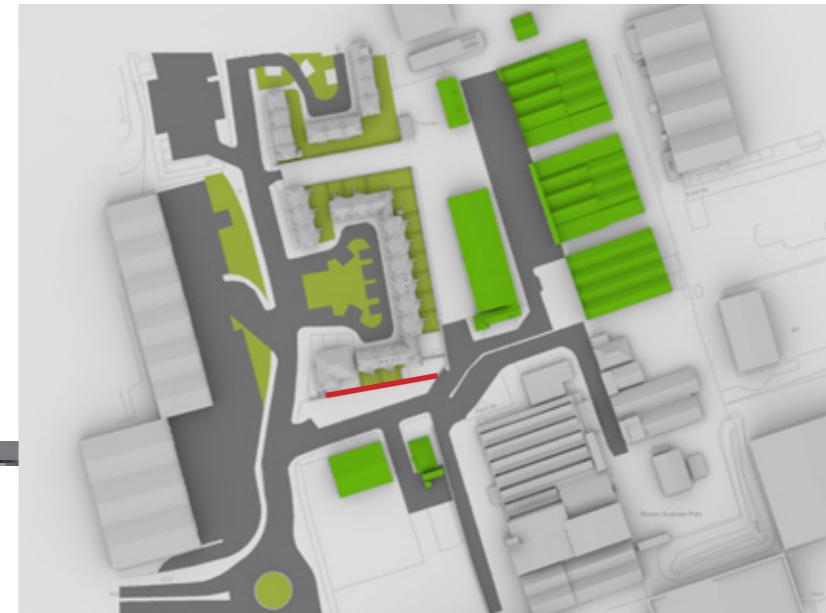

Project Charlton Riverside
Greenwich
London

Title 25-26, 27-28, 29-30 Atlas Gar-
dens,
1-8 Anchor & Hope Ln

Drawn AP Checked PS

Date 15/10/2018 Rel no. 34

Drawing no. 1864-WM18

Sources of information

See Sources of information sheet in
Appendix 11.1



Project Charlton Riverside
Greenwich
London

Title 25-26 Atlas Gardens
(Rear view)
Window Map

Drawn AP Checked PS

Date 15/10/2018 Rel no. 34

Drawing no. 1864-WM19

Sources of information

Cloud 10 Ltd

Charlton ROL-26-10-16-Meters.dwg

Received 25/10/2016

Rockwell Residential

22384_OGL_Rev-1.dwg

Received 24/10/2016

SimpsonHaugh

10046-A-DRG-A-F900-2000-PL-RS.dwg
10046-A-DRG-A-G200-2000-PL-RS.dwg
10046-A-DRG-A-G200-2001-PL-RS.dwg
10046-A-DRG-A-G200-2002-PL-RS.dwg
10046-A-DRG-A-G200-2003-PL-RS.dwg
10046-A-DRG-A-G200-2004-PL-RS.dwg
10046-A-DRG-A-G200-2005-PL-RS.dwg
10046-A-DRG-A-G200-2006-PL-RS.dwg
10046-A-DRG-A-G200-2007-PL-RS.dwg
10046-A-DRG-A-G200-4000-PL-RS.dwg
10046-A-DRG-B-G200-2000-PL-RS.dwg
10046-A-DRG-B-G200-2001-PL-RS.dwg
10046-A-DRG-B-G200-2002-PL-RS.dwg
10046-A-DRG-B-G200-2003-PL-RS.dwg
10046-A-DRG-B-G200-2004-PL-RS.dwg
10046-A-DRG-B-G200-2005-PL-RS.dwg
10046-A-DRG-B-G200-2006-PL-RS.dwg
10046-A-DRG-B-G200-2007-PL-RS.dwg
10046-A-DRG-B-G200-4000-PL-RS.dwg
10046-A-DRG-C-F900-2000-PL-RS.dwg
10046-A-DRG-C-G200-2000-PL-RS.dwg
10046-A-DRG-C-G200-2001-PL-RS.dwg
10046-A-DRG-C-G200-2002-PL-RS.dwg
10046-A-DRG-C-G200-2003-PL-RS.dwg
10046-A-DRG-C-G200-2004-PL-RS.dwg
10046-A-DRG-C-G200-2005-PL-RS.dwg
10046-A-DRG-C-G200-2006-PL-RS.dwg
10046-A-DRG-C-G200-2007-PL-RS.dwg
10046-A-DRG-C-G200-2008-PL-RS.dwg
10046-A-DRG-C-G200-2009-PL-RS.dwg
10046-A-DRG-C-G200-4000-PL-RS.dwg
10046-A-DRG-D-F900-2000-PL-RS.dwg
10046-A-DRG-D-G200-2000-PL-RS.dwg
10046-A-DRG-D-G200-2001-PL-RS.dwg
10046-A-DRG-D-G200-2002-PL-RS .dwg
10046-A-DRG-D-G200-2003-PL-RS.dwg
10046-A-DRG-D-G200-2004-PL-RS.dwg
10046-A-DRG-D-G200-2005-PL-RS.dwg
10046-A-DRG-D-G200-2006-PL-RS.dwg
10046-A-DRG-D-G200-2007-PL-RS.dwg
10046-A-DRG-D-G200-2008-PL-RS.dwg

10046-A-DRG-D-G200-2009-PL-RS.dwg
10046-A-DRG-D-G200-2030-PL-RS.dwg
10046-A-DRG-D-G200-4000-PL-RS.dwg
10046-A-DRG-EF-F900-2000-PL-RS.dwg
10046-A-DRG-EF-G200-2000-PL-RS.dwg
10046-A-DRG-EF-G200-2001-PL-RS.dwg
10046-A-DRG-EF-G200-2002-PL-RS.dwg
10046-A-DRG-EF-G200-2003-PL-RS.dwg
10046-A-DRG-EF-G200-2004-PL-RS.dwg
10046-A-DRG-EF-G200-2005-PL-RS.dwg
10046-A-DRG-EF-G200-2006-PL-RS.dwg
10046-A-DRG-G-F900-2000-PL-RS.dwg
10046-A-DRG-G-G200-2000-PL-RS.dwg
10046-A-DRG-G-G200-2001-PL-RS.dwg
10046-A-DRG-G-G200-2002-PL-RS.dwg
10046-A-DRG-G-G200-2003-PL-RS.dwg
10046-A-DRG-G-G200-2030-PL-RS.dwg
10046-A-DRG-G-G200-4000-PL-RS.dwg
10046-A-DRG-H-G200-2000-PL-RS.dwg
10046-A-DRG-H-G200-2001-PL-RS.dwg
10046-A-DRG-H-G200-2002-PL-RS.dwg
10046-A-DRG-H-G200-2003-PL-RS.dwg
10046-A-DRG-H-G200-4000-PL-RS.dwg
14/09/18

10046-A-DRG-A-G200-2008-PL-RS.DWG
10046-A-DRG-A-G200-2009-PL-RS.DWG
10046-A-DRG-B-G200-2008-PL-RS.DWG
10046-A-DRG-B-G200-2009-PL-RS.DWG
180919

10046-A-DRG-J-F900-2000-PL-RS.dwg
10046-A-DRG-J-G200-2000-PL-RS.dwg
10046-A-DRG-J-G200-2001-PL-RS.dwg
10046-A-DRG-J-G200-2002-PL-RS.dwg
10046-A-DRG-J-G200-2003-PL-RS.dwg
10046-A-DRG-J-G200-2004-PL-RS.dwg
10046-A-DRG-J-G200-2030-PL-RS.dwg
10046-A-DRG-J-G200-4000-PL-RS.dwg
10046-A-DRG-KL-F900-2000-PL-RS.dwg
10046-A-DRG-KL-G200-2000-PL-RS.dwg

10046-A-DRG-KL-G200-2001-PL-RS.dwg
10046-A-DRG-KL-G200-2002-PL-RS.dwg
10046-A-DRG-KL-G200-2003-PL-RS.dwg
10046-A-DRG-KL-G200-2004-PL-RS.dwg
10046-A-DRG-KL-G200-2005-PL-RS.dwg
10046-A-DRG-KL-G200-2006-PL-RS.dwg
10046-A-DRG-KL-G200-2007-PL-RS.dwg
10046-A-DRG-KL-G200-2008-PL-RS.dwg
10046-A-DRG-KL-G200-2009-PL-RS.dwg
10046-A-DRG-KL-G200-2030-PL-RS.dwg
10046-A-DRG-KL-G200-4000-PL-RS.dwg
24/09/18

10046-A-DRG-EF-G200-4000-PL-RS.dwg
10046-A-DRG-G-G200-4000-PL-RS.dwg
10046-A-DRG-Z0-G100-2001-PL-RS.dwg
08/10/18

10046-A-DRG-EF-G200-2007-PL-RS.dwg
10046-A-DRG-EF-G200-2008-PL-RS.dwg
10046-A-DRG-EF-G200-2009-PL-RS.dwg
10046-A-DRG-EF-G200-4000-PL-RS.dwg
10046-A-DRG-MN-G200-2000-PL-RS.dwg

10046-A-DRG-MN-G200-2001-PL-RS.dwg
10046-A-DRG-MN-G200-2002-PL-RS.dwg
10046-A-DRG-MN-G200-2003-PL-RS.dwg
10046-A-DRG-MN-G200-2004-PL-RS.dwg
10046-A-DRG-MN-G200-2005-PL-RS.dwg
10046-A-DRG-MN-G200-2006-PL-RS.dwg
10046-A-DRG-MN-G200-2007-PL-RS.dwg
10046-A-DRG-MN-G200-2008-PL-RS.dwg
10046-A-DRG-MN-G200-2009-PL-RS.dwg
10046-A-DRG-MN-G200-4000-PL-RS.dwg
10046-A-DRG-O-G200-2000-PL-RS.dwg
10046-A-DRG-O-G200-2001-PL-RS.dwg
10046-A-DRG-O-G200-2002-PL-RS.dwg
10046-A-DRG-O-G200-2003-PL-RS.dwg
10046-A-DRG-O-G200-2004-PL-RS.dwg
10046-A-DRG-O-G200-2005-PL-RS.dwg
10046-A-DRG-O-G200-2006-PL-RS.dwg
10046-A-DRG-O-G200-2007-PL-RS.dwg
10046-A-DRG-O-G200-2008-PL-RS.dwg
10046-A-DRG-O-G200-2009-PL-RS.dwg
10046-A-DRG-O-G200-4000-PL-RS.dwg
20/11/18

eb7 Ltd

Site photographs
Ordnance Survey



Appendix 11.2A

Detailed daylight; Vertical Sky Component (VSC), No Sky-Line Contour (NSC), Average Daylight Factor (ADF) and sunlight; Annual Probable Sunlight Hours (APSH) results for existing surrounding properties

Address	Room	Window	Room Use	Existing	Proposed	Loss	Loss	Room Area	Existing	Proposed	Loss	Loss	Existing ADF		Proposed ADF		Existing APSH		Proposed APSH		Total	Winter
				VSC	VSC	%	%		NSC	NSC	%	%	Window	Total	Window	Total	Total	Winter	Total	Winter	Retained	Retained
1-2 Atlas Gardens																						
Ground	R1	W01-L	Bedroom	27.3	24.9	2.4	8.8	127.9	123.3	123.3	0.0	0.0	0.0	0.0	0.0	0.0	N/A	N/A	N/A	N/A	N/A	N/A
		W01-U													1.2	1.2	1.1	1.1				
First	R1	W01-L	Bedroom	31.5	28.9	2.6	8.4	127.9	123.7	123.7	0.0	0.0	0.0	0.0	0.0	0.0	N/A	N/A	N/A	N/A	N/A	N/A
		W01-U													1.3	1.3	1.2	1.2				
3-4 Atlas Gardens																						
Ground	R1	W01-L	Bedroom	23.5	22.2	1.3	5.7	138.6	124.7	124.7	0.0	0.0	0.0	0.0	0.0	0.0	N/A	N/A	N/A	N/A	N/A	N/A
		W01-U													1.0	1.0	1.0	1.0				
First	R1	W01-L	Bedroom	30.1	28.6	1.5	5.0	138.6	133.6	133.6	0.0	0.0	0.0	0.0	0.0	0.0	N/A	N/A	N/A	N/A	N/A	N/A
		W01-U													1.2	1.2	1.1	1.2				
5-6 Atlas Gardens																						
Ground	R1	W01-L	Bedroom	21.7	21.1	0.5	2.4	138.6	117.1	117.1	0.0	0.0	0.0	0.0	0.0	0.0	N/A	N/A	N/A	N/A	N/A	N/A
		W01-U													1.0	1.0	1.0	1.0				
First	R1	W01-L	Bedroom	29.2	28.1	1.1	3.7	138.6	133.6	133.6	0.0	0.0	0.0	0.0	0.0	0.0	N/A	N/A	N/A	N/A	N/A	N/A
		W01-U													1.2	1.2	1.1	1.2				
7-8 Atlas Gardens																						
Ground	R1	W01-L	Bedroom	25.5	25.5	0.0	0.0	138.6	131.7	131.7	0.0	0.0	0.0	0.0	0.0	0.0	N/A	N/A	N/A	N/A	N/A	N/A
		W01-U													1.1	1.1	1.1	1.1				
First	R1	W01-L	Bedroom	30.0	30.0	0.0	0.0	138.6	133.3	133.3	0.0	0.0	0.0	0.0	0.0	0.0	N/A	N/A	N/A	N/A	N/A	N/A
		W01-U													1.2	1.2	1.2	1.2				
9-10 Atlas Gardens																						
Ground	R1	W01-L	Bedroom	25.7	25.7	0.0	0.0	138.6	131.4	131.4	0.0	0.0	0.0	0.0	0.0	0.0	N/A	N/A	N/A	N/A	N/A	N/A
		W01-U													1.1	1.1	1.1	1.1				
First	R1	W01-L	Bedroom	29.8	29.8	0.0	0.0	138.6	133.5	133.5	0.0	0.0	0.0	0.0	0.0	0.0	N/A	N/A	N/A	N/A	N/A	N/A
		W01-U													1.2	1.2	1.2	1.2				
11-12 Atlas Gardens																						
Ground	R1	W01-L	Bedroom	34.6	33.0	1.6	4.7	135.8	131.9	131.9	0.0	0.0	0.0	0.0	0.0	0.0	N/A	N/A	N/A	N/A	N/A	N/A
		W01-U													1.3	1.3	1.3	1.3				

Address	Room	Window	Room Use	Existing	Proposed	Loss	Loss	Room	Existing	Proposed	Loss	Loss	Existing ADF		Proposed ADF		Existing APSH		Proposed APSH		Total	Winter
				VSC	VSC	%	Area	NSC	NSC	%	Window	Total	Window	Total	Total	Winter	Total	Winter	Retained	Retained		
			W01-U					138.6	133.7	129.7	4.0	3.0	1.3	1.3	1.1	1.1						
17-18 Atlas Gardens																						
Ground	R1	W01-L	Bedroom	25.9	19.5	6.5	25.0						0.0		0.0		N/A	N/A	N/A	N/A	N/A	N/A
		W01-U						138.6	131.4	101.0	30.5	23.2	1.1	1.1	0.9	0.9						
First	R1	W01-L	Bedroom	31.2	24.1	7.1	22.7						0.0		0.0		N/A	N/A	N/A	N/A	N/A	N/A
		W01-U						138.6	133.6	126.6	7.1	5.3	1.3	1.3	1.1	1.1						
19-20 Atlas Gardens																						
Ground	R1	W01-L	Bedroom	26.3	19.8	6.6	24.9						0.0		0.0		N/A	N/A	N/A	N/A	N/A	N/A
		W01-U						138.6	131.6	100.4	31.3	23.7	1.1	1.1	0.9	0.9						
First	R1	W01-L	Bedroom	31.6	24.5	7.1	22.5						0.0		0.0		N/A	N/A	N/A	N/A	N/A	N/A
		W01-U						138.6	133.6	124.2	9.4	7.0	1.3	1.3	1.1	1.1						
Second	R1	W01	Unknown	85.7	80.5	5.2	6.1	138.6	115.3	115.3	0.0	0.0	0.8	0.8	0.8	0.8	N/A	N/A	N/A	N/A	N/A	N/A
Second	R2	W02	Unknown	86.9	81.8	5.1	5.9	86.3	70.9	70.9	0.0	0.0	1.1	1.1	1.1	1.1	N/A	N/A	N/A	N/A	N/A	N/A
Second	R3	W03	Unknown	85.6	80.6	5.0	5.9	67.4	52.3	52.3	0.0	0.0	1.3	1.3	1.3	1.3	N/A	N/A	N/A	N/A	N/A	N/A
21-22 Atlas Gardens																						
Ground	R1	W01-L	Bedroom	26.2	19.7	6.5	24.9						0.0		0.0		N/A	N/A	N/A	N/A	N/A	N/A
		W01-U						138.6	131.0	103.8	27.2	20.7	1.1	1.1	0.9	0.9						
First	R1	W01-L	Bedroom	31.5	24.6	6.9	21.9						0.0		0.0		N/A	N/A	N/A	N/A	N/A	N/A
		W01-U						138.6	133.3	123.9	9.4	7.1	1.3	1.3	1.1	1.1						
23-24 Atlas Gardens																						
Ground	R1	W01-L	Bedroom	26.2	19.7	6.5	24.8						0.0		0.0		N/A	N/A	N/A	N/A	N/A	N/A
		W01-U						138.6	131.0	104.8	26.1	19.9	1.1	1.1	0.9	0.9						
First	R1	W01-L	Bedroom	31.6	24.8	6.8	21.6						0.0		0.0		N/A	N/A	N/A	N/A	N/A	N/A
		W01-U						138.6	133.2	123.8	9.4	7.1	1.3	1.3	1.1	1.1						
25-26 Atlas Gardens																						
Ground	R1	W01-L	Bedroom	26.3	22.7	3.6	13.7						0.0		0.0		N/A	N/A	N/A	N/A	N/A	N/A
		W01-U											1.1		1.0							

Address	Room	Window	Room Use	Existing	Proposed	Loss	Loss	Room Area	Existing	Proposed	Loss	Loss	Existing ADF		Proposed ADF		Existing APSH		Proposed APSH		Total	Winter	
				VSC	VSC	%	%		NSC	NSC	%	%	Window	Total	Window	Total	Total	Winter	Total	Winter	Retained	Retained	
	R1	W02		27.2	27.2	0.0	0.0							0.6	0.6			N/A	N/A	N/A	N/A	N/A	N/A
	R1	W03		24.6	24.6	0.0	0.0							1.0	1.0			14	0	14	0	1.0	0.0
	R1	W04		7.8	7.8	0.0	0.0	155.7	155.7	155.7	0.0	0.0		0.2	2.9	0.2	2.8	12	0	12	0	1.0	0.0
Ground	R2	W05	Unknown	23.4	19.1	4.3	18.2							0.6	0.5			N/A	N/A	N/A	N/A	N/A	N/A
	R2	W06		34.6	30.1	4.5	12.9							1.6	1.4			N/A	N/A	N/A	N/A	N/A	N/A
	R2	W07		25.7	23.9	1.8	6.8	119.1	116.9	115.1	1.8	1.6		0.6	2.8	0.6	2.6	31	3	27	3	0.9	1.0
Ground	R5	W14-L	Bedroom	35.6	28.8	6.8	19.1							0.0	0.0			82	27	72	17	0.9	0.6
		W14-U						135.8	131.6	106.7	25.0	19.0		1.3	1.4	1.1	1.1						
First	R1	W01-L	Bedroom	29.0	25.5	3.5	11.9							0.0	0.0			N/A	N/A	N/A	N/A	N/A	N/A
		W01-U												1.2	1.1								
	R1	W02-L		29.2	29.2	0.0	0.0							0.0	0.0			N/A	N/A	N/A	N/A	N/A	N/A
		W02-U												0.5	0.5								
	R1	W03-L		31.3	31.3	0.0	0.0							0.0	0.0			36	2	36	2	1.0	1.0
		W03-U												1.1	1.1								
	R1	W04-L		13.2	13.2	0.0	0.0							0.0	0.0			21	0	21	0	1.0	0.0
		W04-U						155.7	155.7	155.7	0.0	0.0		0.2	3.2	0.2	3.1						
First	R2	W05-L	Bedroom	27.6	23.3	4.4	15.8							0.0	0.0			N/A	N/A	N/A	N/A	N/A	N/A
		W05-U												0.6	0.5								
	R2	W06-L		36.7	32.1	4.5	12.4							0.0	0.0			N/A	N/A	N/A	N/A	N/A	N/A
		W06-U												1.5	1.4								
	R2	W07-L		28.7	26.9	1.7	6.1							0.0	0.0			38	6	35	6	0.9	1.0
		W07-U						119.1	118.0	115.8	2.2	1.9		0.6	2.8	0.6	2.6						
First	R5	W14-L	Bedroom	35.7	29.4	6.3	17.7							0.0	0.0			81	28	71	18	0.9	0.6
		W14-U						135.8	131.6	120.7	10.9	8.3		1.3	1.3	1.1	1.1						
27-28 Atlas Gardens																							
Ground	R1	W01-L	Bedroom	27.8	22.1	5.7	20.5							0.0	0.0			59	18	51	10	0.9	0.6
		W01-U						138.6	131.7	121.1	10.7	8.1		1.2	1.2	1.0	1.0						
First	R1	W01-L	Bedroom	31.9	26.0	5.8	18.3							0.0	0.0			72	22	62	12	0.9	0.5
		W01-U						138.6	133.6	133.2	0.4	0.3		1.3	1.3	1.1	1.1						
Second	R2	W01	Unknown	85.2	80.7	4.5	5.3	107.4	83.5	83.1	0.3	0.4		1.0	1.0	1.0	1.0	94	30	88	24	0.9	0.8
Second	R3	W02	Unknown	85.9	81.2	4.7	5.5	49.3	36.5	36.5	0.0	0.0		1.6	1.6	1.6	1.6	93	30	87	24	0.9	0.8
Second	R4	W03	Unknown	84.6	79.8	4.8	5.7	44.8	34.1	34.1	0.0	0.0		1.7	1.7	1.7	1.7	92	29	85	22	0.9	0.8

Address	Room	Window	Room Use	Existing	Proposed	Loss	Loss	Room Area	Existing	Proposed	Loss	Loss	Existing ADF		Proposed ADF		Existing APSH		Proposed APSH		Total Retained	Winter Retained
				VSC	VSC	%	%		NSC	NSC	%	%	Window	Total	Window	Total	Total	Winter	Total	Winter		
29-30 Atlas Gardens																						
Ground	R1	W01-L	Bedroom	26.5	19.3	7.2	27.1	138.6	131.3	110.6	20.7	15.7	0.0	0.0	56	17	46	7	0.8	0.4		
		W01-U		1.2	1.2	1.0	1.0															
First	R1	W01-L	Bedroom	31.2	23.9	7.3	23.5	138.6	133.4	129.6	3.8	2.8	0.0	0.0	71	22	62	13	0.9	0.6		
		W01-U		1.3	1.3	1.1	1.1															
21-22 Derrick Gardens																						
Ground	R1	W01-L	Bedroom	33.6	29.1	4.4	13.2	85.4	82.8	81.8	1.0	1.2	0.0	0.0	N/A	N/A	N/A	N/A	N/A	N/A	N/A	N/A
		W01-U		1.9	1.9	1.7	1.7															
First	R1	W01-L	Bedroom	35.0	30.3	4.7	13.4	85.4	82.8	82.6	0.2	0.2	0.0	0.0	N/A	N/A	N/A	N/A	N/A	N/A	N/A	N/A
		W01-U		1.8	1.8	1.6	1.6															
Second	R1	W01	Unknown	34.1	29.5	4.7	13.6	77.5	69.6	69.6	0.0	0.0	1.5	1.5	1.3	1.3	N/A	N/A	N/A	N/A	N/A	N/A
23-24 Derrick Gardens																						
Ground	R3	W05-L	Bedroom	35.0	29.4	5.6	16.1	85.4	82.2	82.2	0.0	0.0	0.0	0.0	N/A	N/A	N/A	N/A	N/A	N/A	N/A	N/A
		W05-U		1.9	1.9	1.7	1.7															
First	R3	W05-L	Bedroom	35.6	29.8	5.9	16.4	85.4	82.2	82.2	0.0	0.0	0.0	0.0	N/A	N/A	N/A	N/A	N/A	N/A	N/A	N/A
		W05-U		1.8	1.9	1.6	1.6															
25-26 Derrick Gardens																						
Ground	R1	W01-L	Bedroom	35.2	29.3	5.9	16.9	85.4	82.6	77.4	5.2	6.3	0.0	0.0	N/A	N/A	N/A	N/A	N/A	N/A	N/A	N/A
		W01-U		1.9	1.9	1.7	1.7															
First	R1	W01-L	Bedroom	35.7	29.6	6.2	17.3	85.4	82.6	78.8	3.9	4.7	0.0	0.0	N/A	N/A	N/A	N/A	N/A	N/A	N/A	N/A
		W01-U		1.9	1.9	1.6	1.6															
27-28 Derrick Gardens																						
Ground	R3	W05-L	Bedroom	35.1	28.9	6.2	17.7	85.4	82.5	79.1	3.4	4.1	0.0	0.0	N/A	N/A	N/A	N/A	N/A	N/A	N/A	N/A
		W05-U		1.9	1.9	1.6	1.6															
First	R3	W05-L	Bedroom	35.7	28.8	6.9	19.4	85.4	82.5	80.2	2.3	2.8	0.0	0.0	N/A	N/A	N/A	N/A	N/A	N/A	N/A	N/A
		W05-U		1.9	1.9	1.5	1.6															
29-30 Derrick Gardens																						

Address	Room	Window	Room Use	Existing	Proposed	Loss	Loss	Room Area	Existing	Proposed	Loss	Loss	Existing ADF		Proposed ADF		Existing APSH		Proposed APSH		Total	Winter
				VSC	VSC	%	%		NSC	NSC	%	%	Window	Total	Window	Total	Total	Winter	Total	Winter	Retained	Retained
	R4	W05-U W06-L W06-U		23.6	21.9	1.6	6.9	153.3	140.9	128.7	12.2	8.7	0.5 0.0 0.4	0.4 0.0 0.9	N/A	N/A	N/A	N/A	N/A	N/A	N/A	N/A
Ground	R5 R5	W07 W08-L W08-U	Unknown	30.2 29.2	27.5 27.1	2.8 2.0	9.1 6.9	85.4	83.4	83.4	0.0	0.0	1.2 0.1 0.8	1.2 0.1 2.2	N/A	N/A	N/A	N/A	N/A	N/A	N/A	N/A
First	R1	W01-L W01-U	Bedroom	32.5	31.8	0.7	2.1	141.8	135.3	135.3	0.0	0.0	0.0 1.3	0.0 1.3	N/A	N/A	N/A	N/A	N/A	N/A	N/A	N/A
First	R4	W05-L W05-U	Bedroom	33.7	31.1	2.6	7.6	106.0	102.3	102.3	0.0	0.0	0.0 1.5	0.0 1.6	N/A	N/A	N/A	N/A	N/A	N/A	N/A	N/A
1 to 8 Anchor & Hope Lane																						
Ground	R1	W01	Unknown	24.3	24.3	0.0	0.0	70.1	67.8	67.8	0.0	0.0	1.1	1.1	1.1	1.1	33	11	33	11	1.0	1.0
Ground	R2	W02	Unknown	24.3	24.3	0.0	0.0	50.7	50.0	50.0	0.0	0.0	1.3	1.3	1.3	1.3	33	11	33	11	1.0	1.0
Ground	R3	W03	Unknown	20.2	20.2	0.0	0.0	43.6	38.2	38.2	0.0	0.0	0.4	0.4	0.4	0.4	27	8	27	8	1.0	1.0
Ground	R4	W04-L W04-U	Unknown	29.8	22.3	7.5	25.3						0.1 0.9	0.1 0.7	71	20	54	6	0.8	0.3		
	R4	W05		35.6	26.7	8.9	25.0	149.1	147.8	127.7	20.1	13.6	0.9	1.9	0.7	1.5	86	28	68	13	0.8	0.5
Ground	R5	W06	Unknown	35.7	26.5	9.1	25.6	134.2	130.7	102.0	28.7	21.9	1.0	1.0	0.8	0.8	88	29	73	15	0.8	0.5
Ground	R6	W07-L W07-U	Unknown	22.7	14.7	8.0	35.1						0.1 0.6	0.0 0.5	49	16	38	6	0.8	0.4		
	R6	W08		28.1	20.2	7.9	28.2	181.4	171.7	168.7	3.0	1.7	0.7	1.3	0.5	1.0	59	20	48	10	0.8	0.5
Ground	R7 R7	W09 W10-L W10-U	Unknown	34.6 28.2	26.3 22.1	8.3 6.1	24.0 21.6						0.8 0.1 0.7	0.7 0.1 1.6	80 61	26 21	67 50	13 10	0.8 0.8	0.5 0.5		
First	R1	W01	Unknown	32.8	24.0	8.8	26.7	149.1	148.0	139.1	8.9	6.0	2.2	2.2	1.7	1.7	80	30	64	16	0.8	0.5
First	R2	W02	Unknown	32.7	23.6	9.1	27.9	134.2	130.5	103.0	27.6	21.1	0.9	0.9	0.7	0.7	82	30	68	17	0.8	0.6
First	R3	W03	Unknown	27.4	19.6	7.8	28.3	181.4	169.2	146.3	22.9	13.5	0.6	0.6	0.5	0.5	66	21	54	10	0.8	0.5
First	R4 R4	W04 W05-L	Unknown	32.4 26.4	24.4 20.2	8.0 6.3	24.8 23.7						0.7 0.1	0.6 0.1	78 53	27 23	67 42	16 12	0.9 0.8	0.6 0.5		

Address	Room	Window	Room	Existing	Proposed	Loss	Loss	Room	Existing	Proposed	Loss	Loss	Existing ADF	Proposed ADF	Existing APSH	Proposed APSH	Total	Winter
			Use	VSC	VSC		%	Area	NSC	NSC		%	Window	Total	Window	Total	Retained	Retained
		W05-U						172.4	172.3	160.1	12.1	7.0	0.5	1.4	0.4	1.1		



Appendix 11.3A

Sunlight amenity assessment

Title
 Overshadowing Assessments
 External Areas

BRE's Sun On Ground
 Area seeing at least two
 hours of sunlight

YES

NO

Day: 21st March
 Latitude: 51.4°N
 Effective day length: 10 hours
 *Min solar angle 10°
 (BR209 3.3.8)

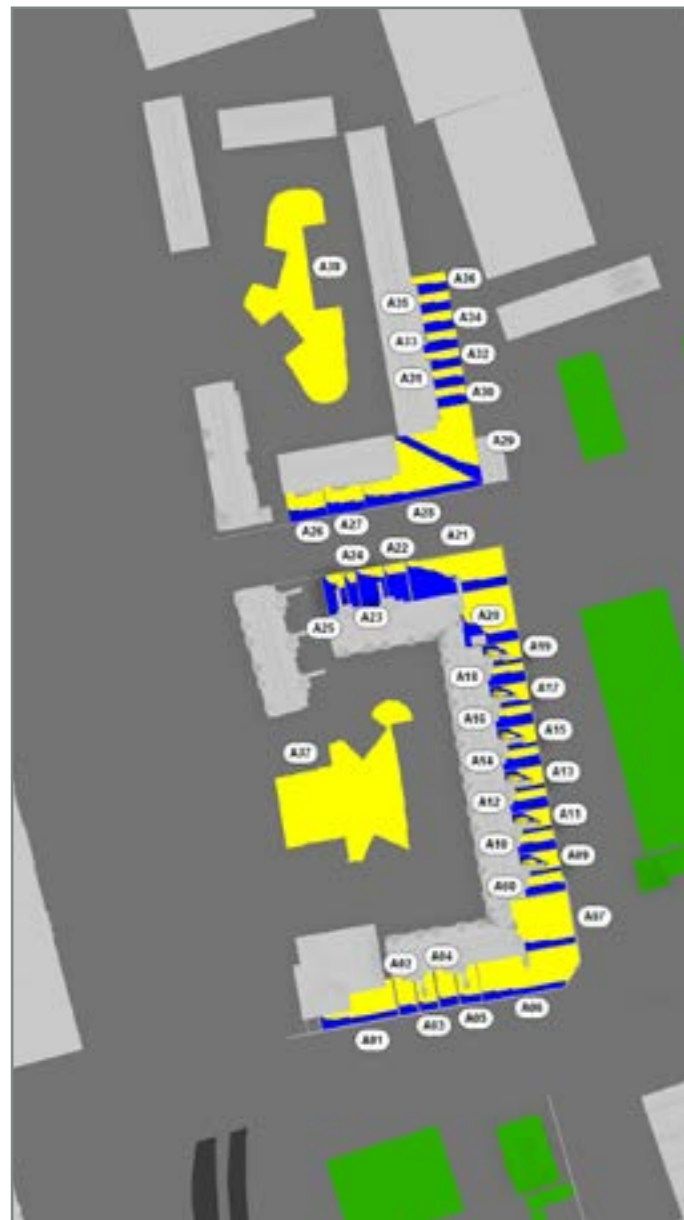

Fig. 1: BRE's Sun On Ground - Existing Scenario

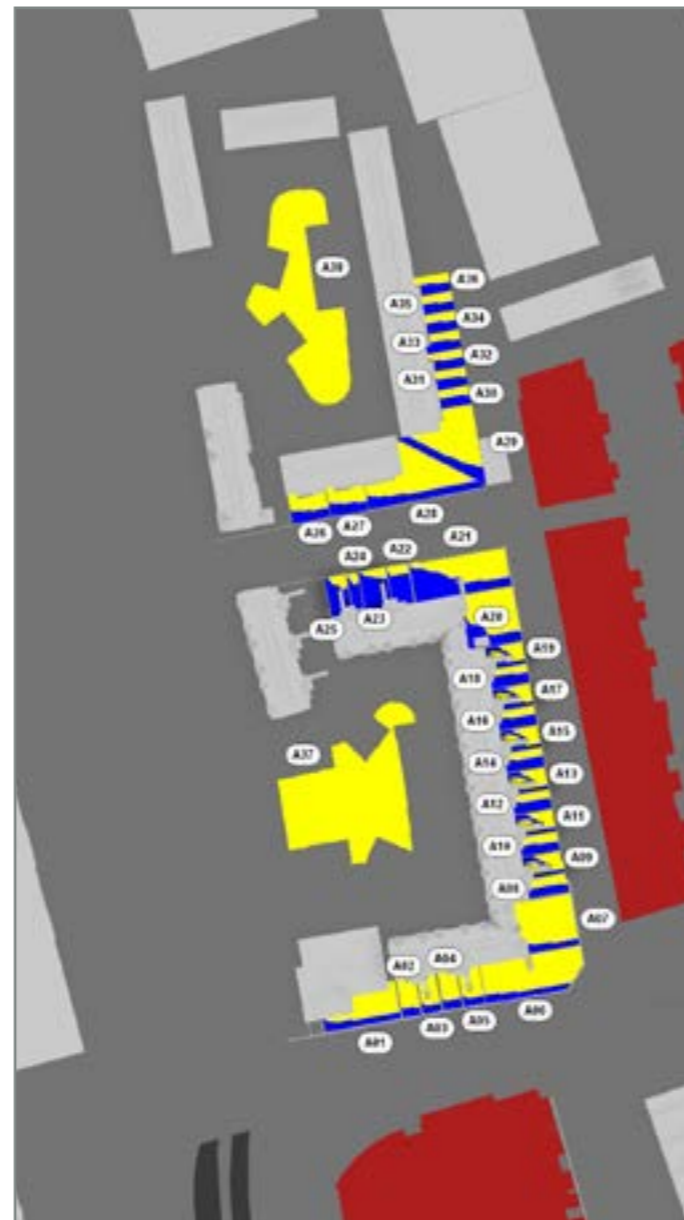

Fig. 2: BRE's Sun On Ground - Proposed Scenario

Zone Name	Area (m2)	Sunlit Area*		Loss [%]
		Existing [%]	Proposed [%]	
A01	99.7	68.3	67.4	1.3
A02	34.6	75.0	73.9	1.4
A03	35.2	74.9	74.6	0.4
A04	35.3	73.3	72.2	1.5
A05	38.5	75.2	74.7	0.7
A06	178.1	82.9	82.8	0.2
A07	143.3	84.9	84.9	0.0
A08	35.2	46.5	46.5	0.0
A09	39.5	71.9	63.6	11.6
A10	34.0	43.5	43.5	0.0
A11	39.2	72.5	63.6	12.2
A12	33.6	39.3	39.3	0.0
A13	38.9	70.1	62.4	11.0
A14	33.4	38.9	38.9	0.0
A15	38.7	69.1	61.5	11.0
A16	33.6	38.3	38.3	0.0
A17	38.5	66.8	59.0	11.7
A18	32.6	34.8	34.8	0.0
A19	38.1	68.3	59.8	12.4
A20	129.3	75.7	73.3	3.2
A21	179.2	54.9	51.5	6.3
A22	38.8	21.1	21.1	0.0
A23	50.3	16.7	16.7	0.0
A24	20.4	20.7	20.7	0.0
A25	39.0	21.4	21.4	0.0
A26	52.1	60.0	60.0	0.0
A27	50.0	57.9	57.9	0.0
A28	174.6	68.0	68.0	0.0
A29	149.9	73.4	71.2	3.0
A30	32.0	41.8	41.3	1.3
A31	32.0	41.2	41.2	0.0
A32	29.1	42.6	42.6	0.0
A33	30.4	40.1	40.1	0.0
A34	33.0	43.4	43.1	0.6
A35	33.3	44.0	44.0	0.0
A36	30.1	48.8	48.8	0.0
A37	557.2	100.0	100.0	0.0
A38	486.9	100.0	100.0	0.0

*Sunlit Area = Area receiving >2hrs. of sunlight on 21st March

Table 1: Results



Project: Charlton Riverside
 Greenwich

Reference: 1864_R35_SA01ext

Drawn: VL Checked: -

Date: 29/11/2018 Rel no.: 01

Drawing no.: 1864_R35_SA01ext-1

BRE's Sun On Ground
 Area seeing at least two hours of sunlight

YES

NO

Day: 21st March
 Latitude: 51.4°N
 Effective day length: 10 hours
 *Min solar angle 10°
 (BR209 3.3.8)

Zone Name	Area (m2)	Sunlit Area* (%)
B1	843.3	99.1
B2	2,299.1	50.0
B3	1,999.8	97.7
B4	415.2	100.0
B5	500.1	99.9
B6	547.3	100.0
B7	1,313.4	82.0
B8	1,159.8	18.4
B9	900.4	99.2

*Sunlit Area = Area receiving at least 2hrs. of sunlight on 21st March

Table 1: Results

Title
 BRE's Sun-On-Ground
 Internal Areas

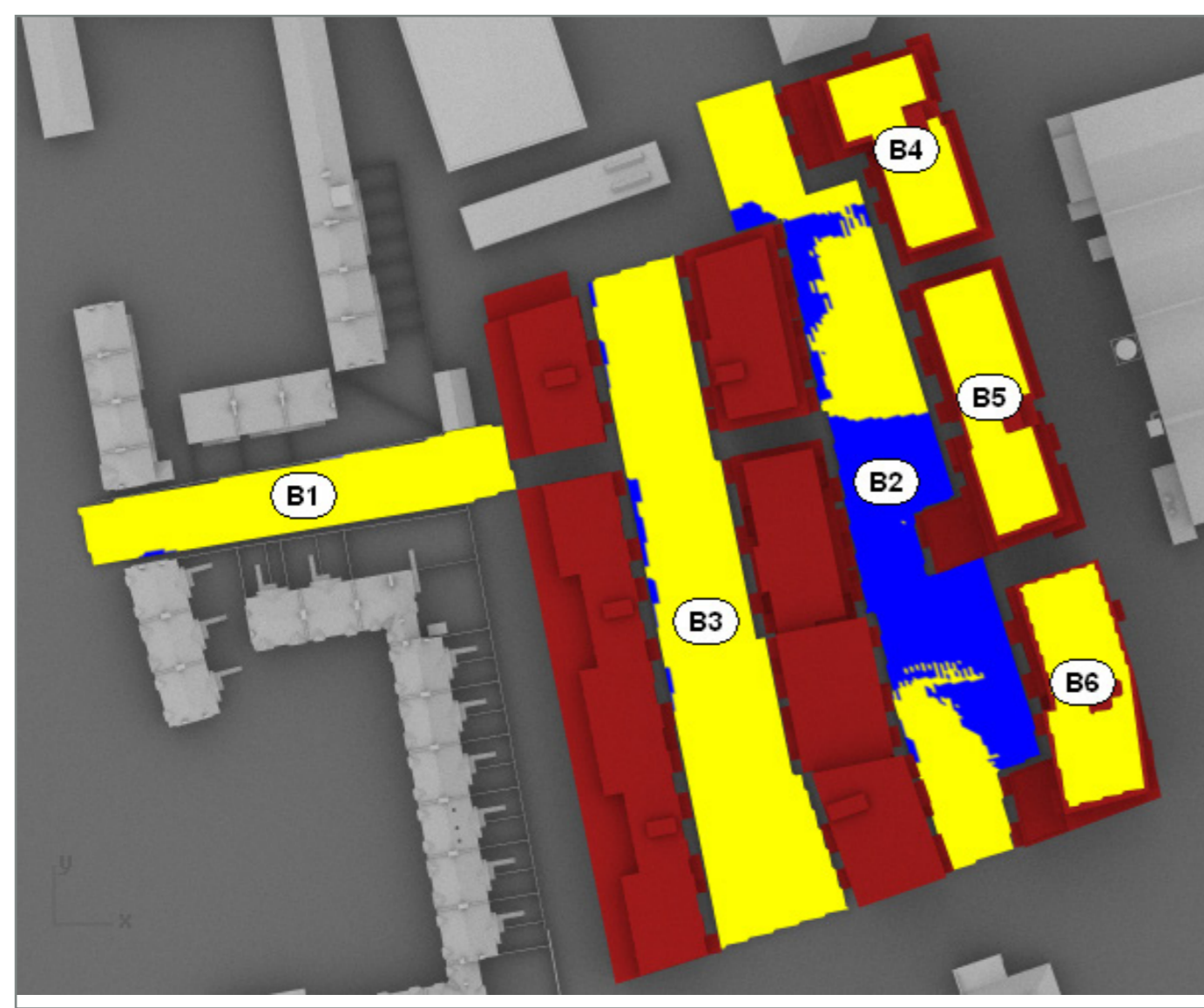

Fig. 1: BRE's Sun On Ground - Proposed Scenario - North Site

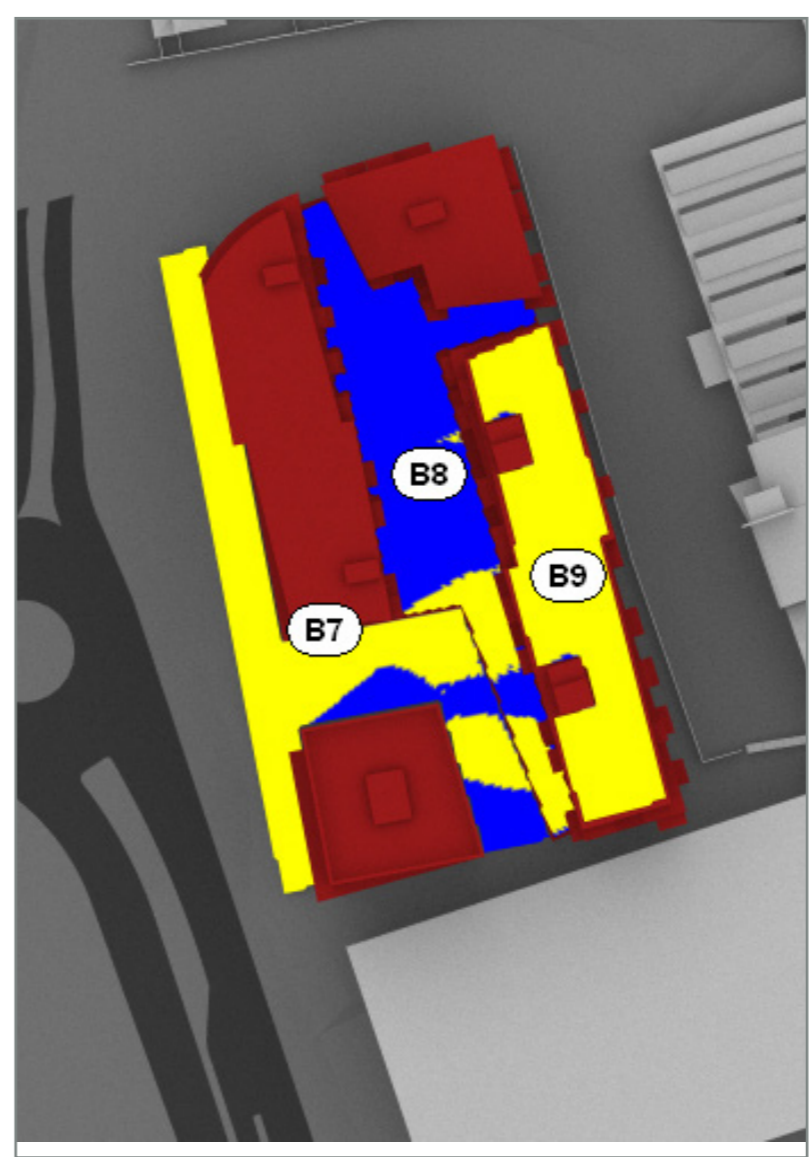
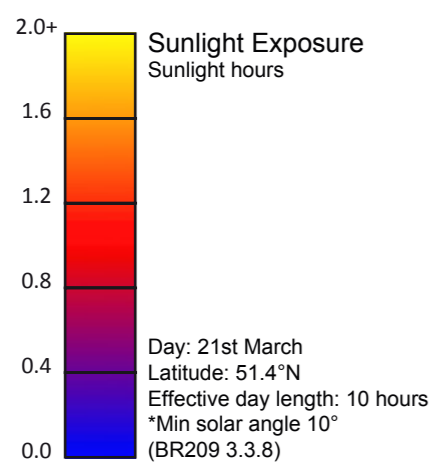

Fig. 2: BRE's Sun On Ground - Proposed Scenario - South Site



Project	Charlton Riverside Greenwich		
Reference	1864_R35_SA01int		
Drawn	VL	Checked	-
Date	29/11/2018	Rel no.	01
Drawing no.	1864_R35_SA01int-1		



Title
 Sunlight Exposure
 Internal Areas

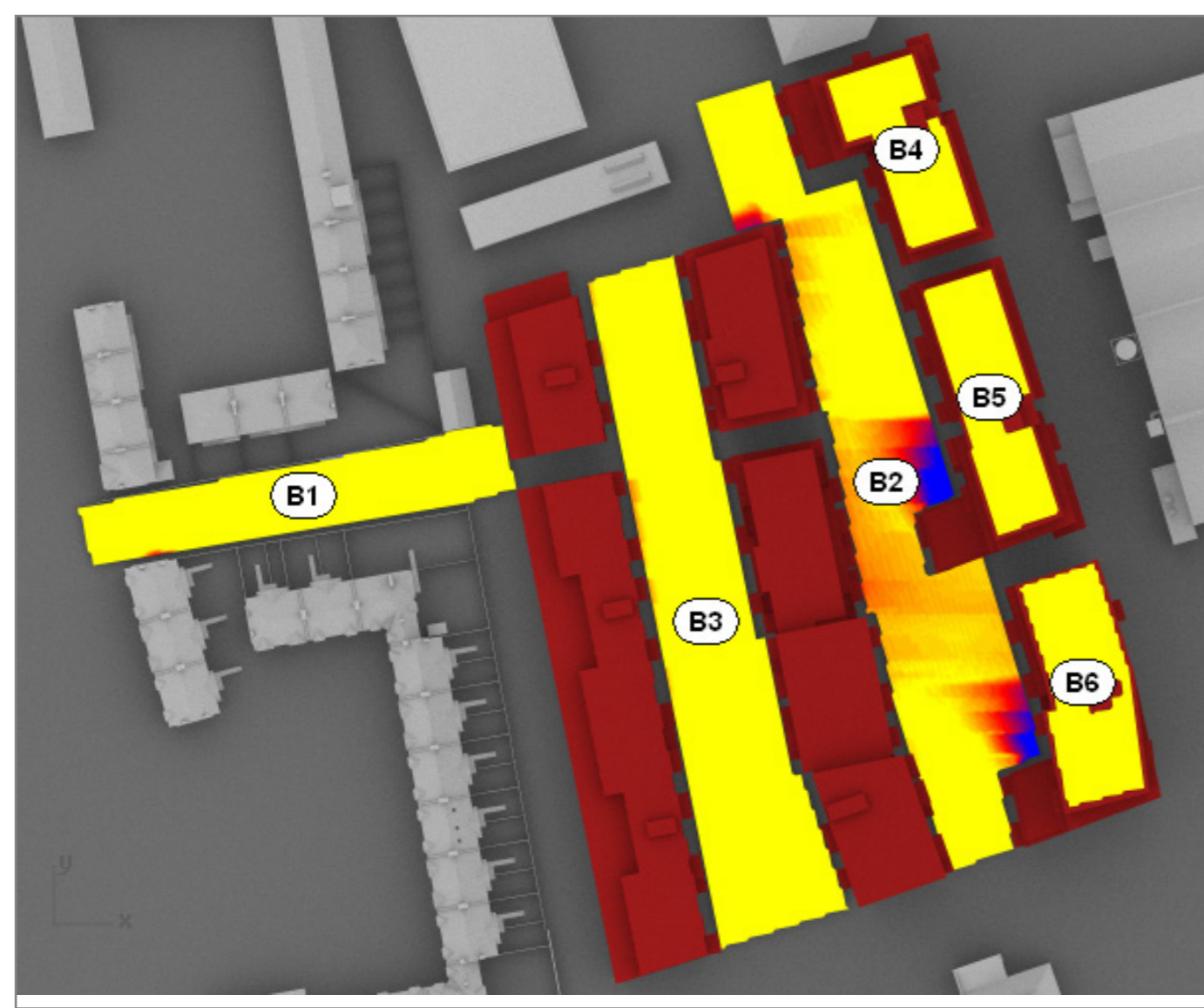

Fig. 3: Sunlight exposure 21st March - Proposed Scenario - North Site

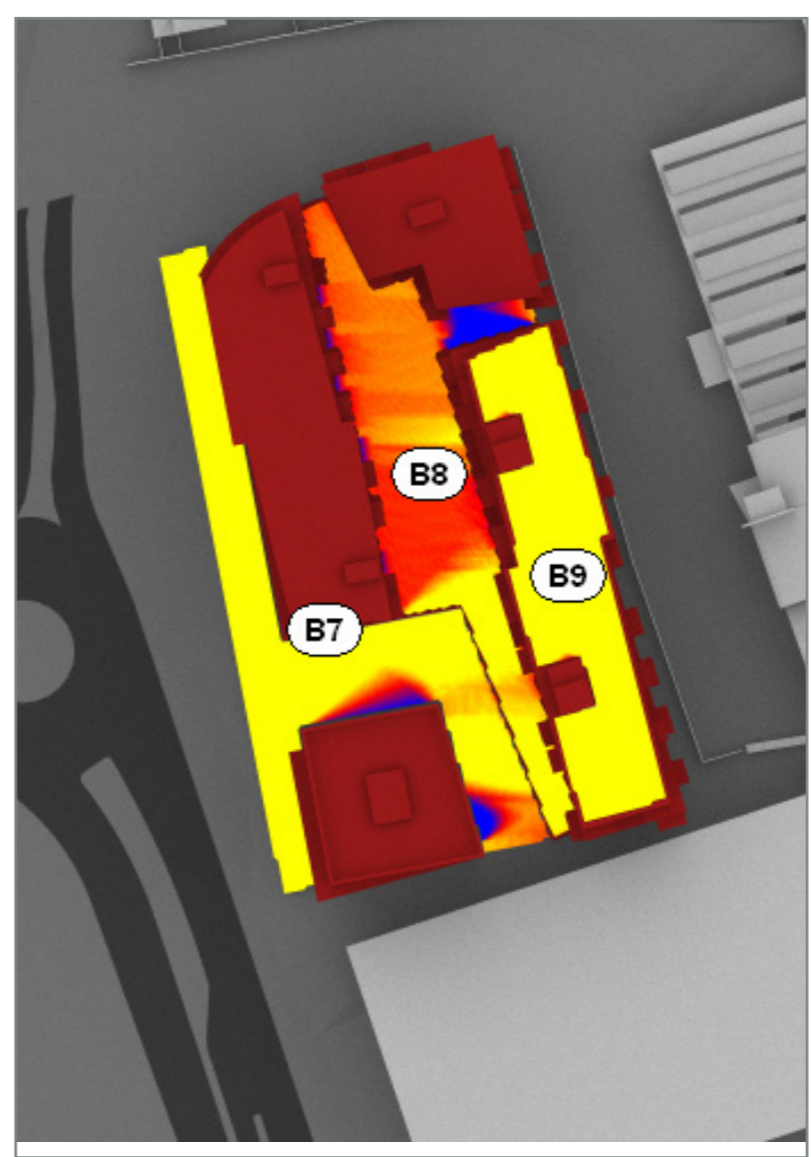

Fig. 4: Sunlight exposure 21st March - Proposed Scenario - South Site



Project Charlton Riverside
 Greenwich

Reference 1864_R35_SA01int

Drawn VL Checked -

Date 29/11/2018 Rel no. 01

Drawing no. 1864_R35_SA01int-2



Appendix 11.4A

Transient overshadowing assessment

Existing Scenario



Proposed Scenario

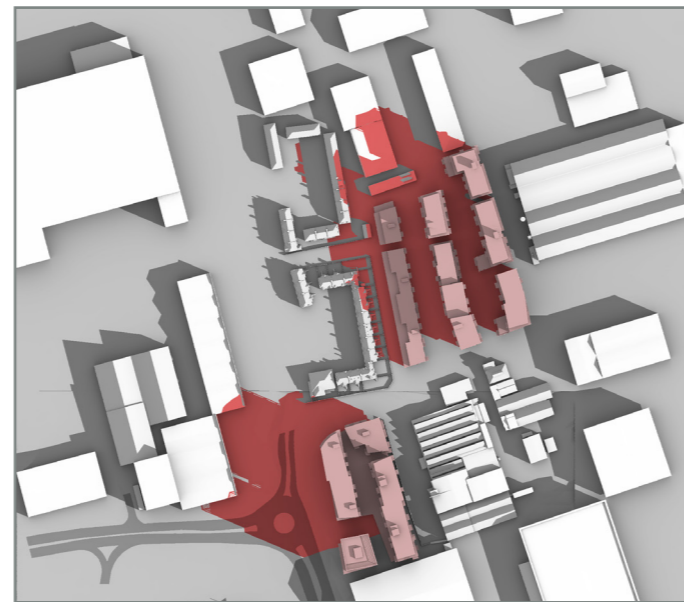

Difference

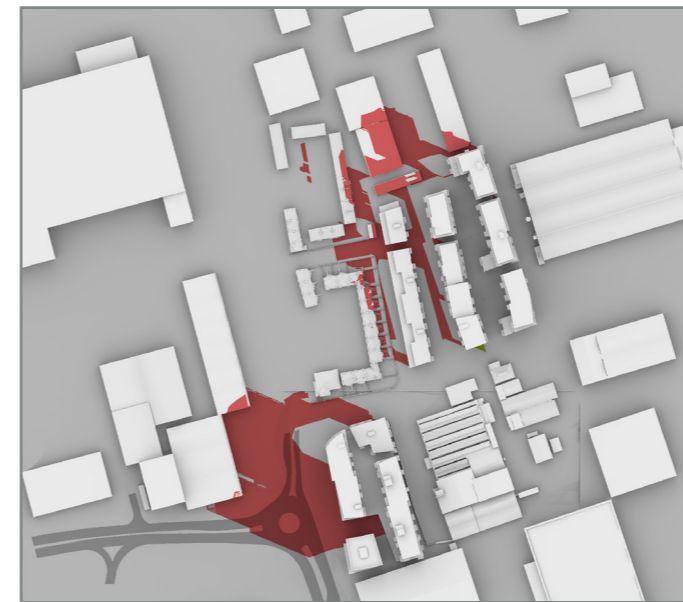

8:00GMT

Title

Transient Overshadowing
Hourly Shadows
21st March

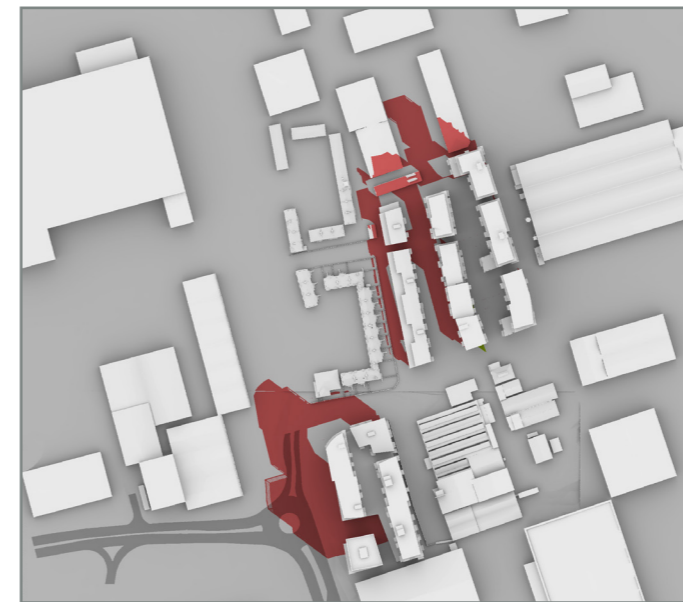
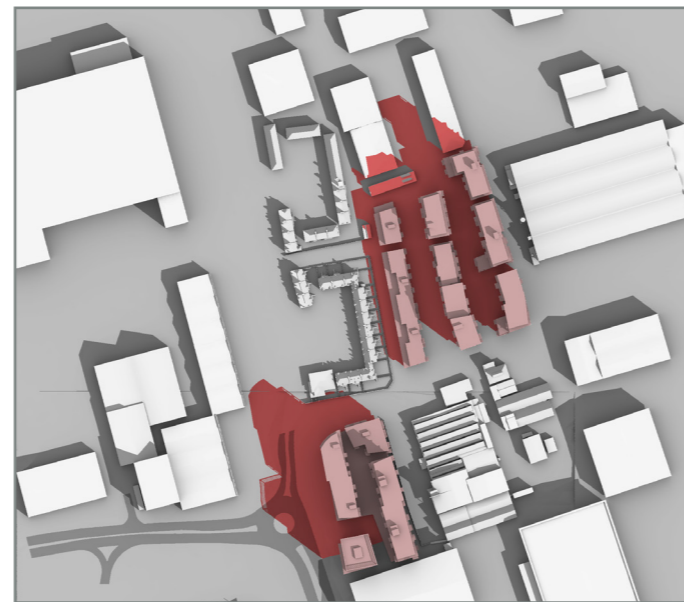

9:00GMT

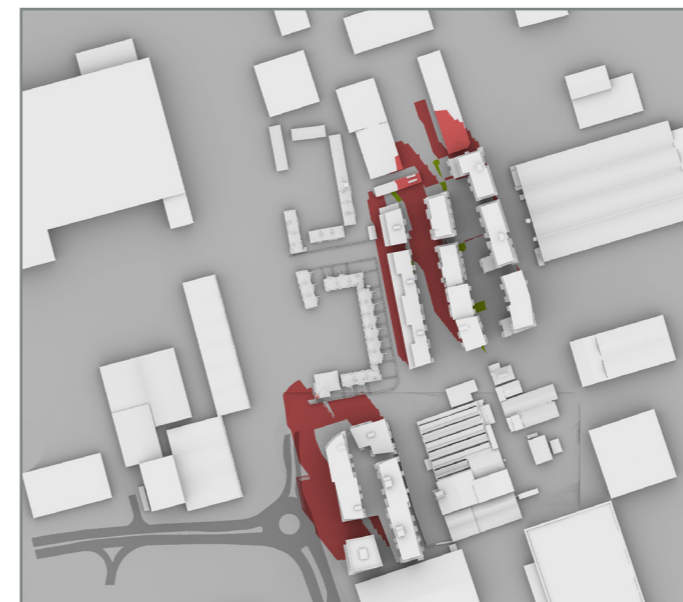
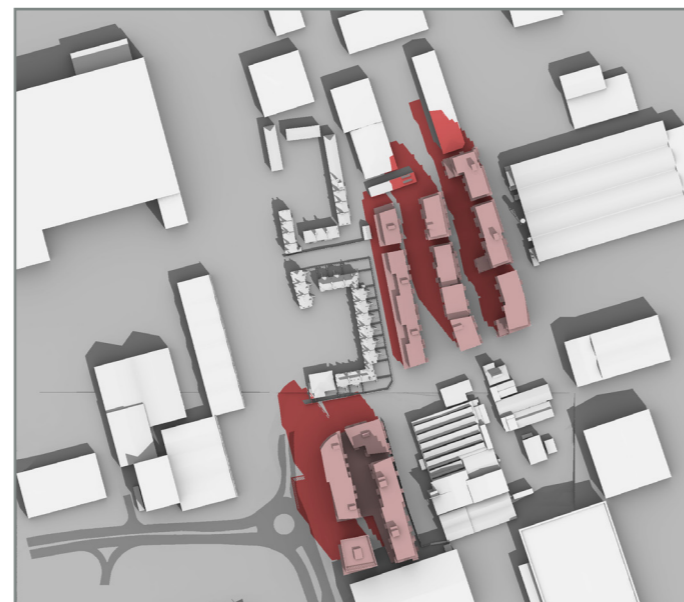

10:00GMT

 Existing

 Proposed

NORTH



Latitude: 51.4N
Min. solar altitude 10 degrees
(BR209 3.3.8)

Project Charlton Riverside
London

Reference 1864_R35_TS01

Drawn VL Checked PP

Date 29/11/2018 Rel no. 01

Drawing no. 1864_R35_TS01-5

Existing Scenario



Proposed Scenario

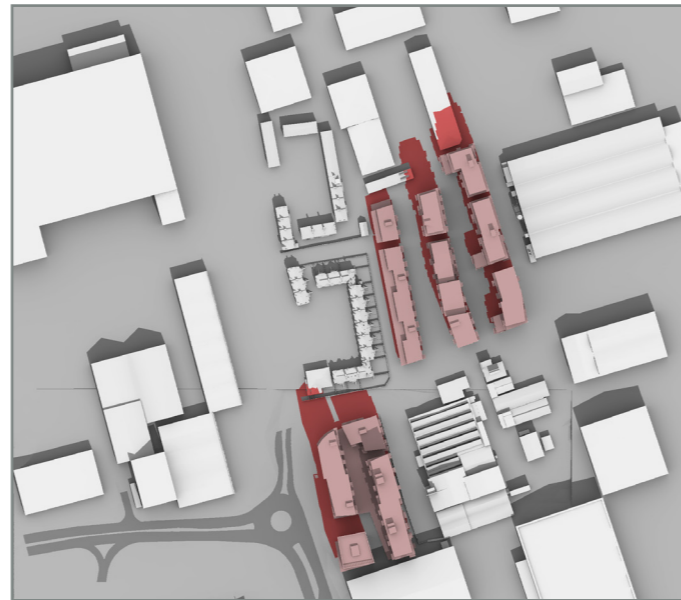

Difference

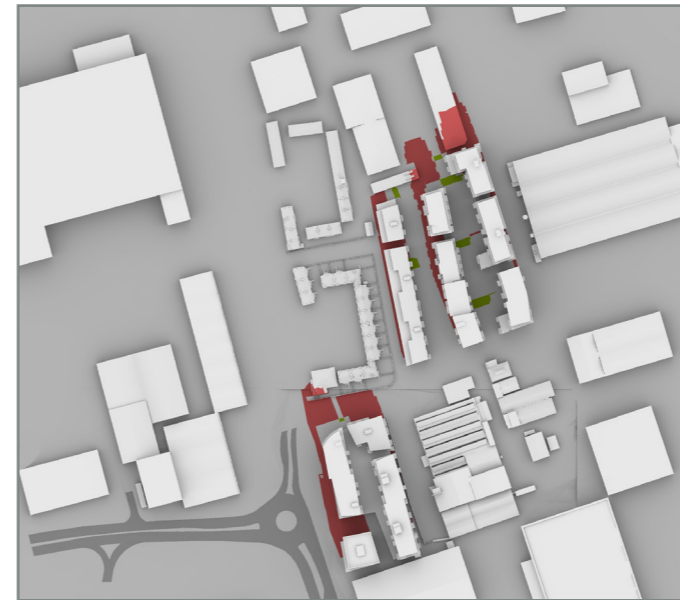

11:00_{GMT}

Title

Transient Overshadowing
Hourly Shadows
21st March

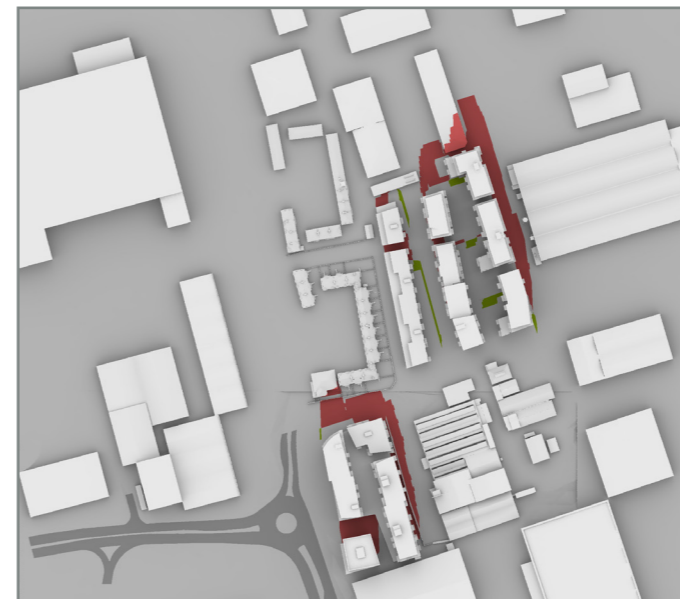
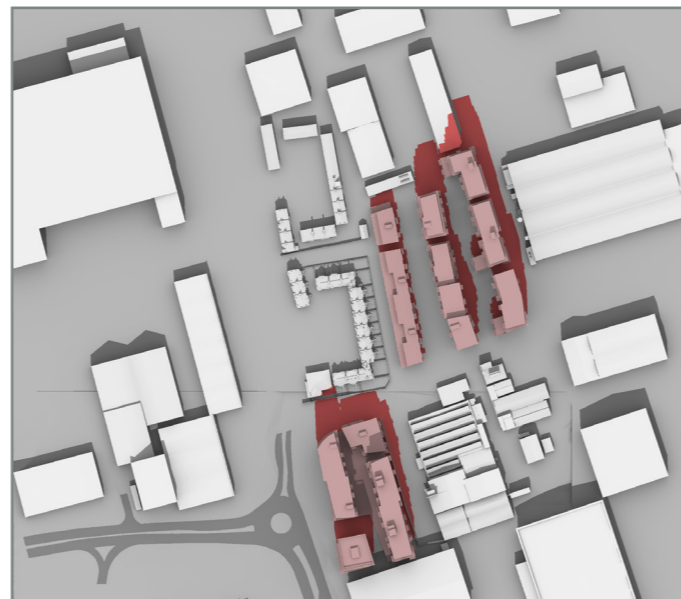

12:00_{GMT}

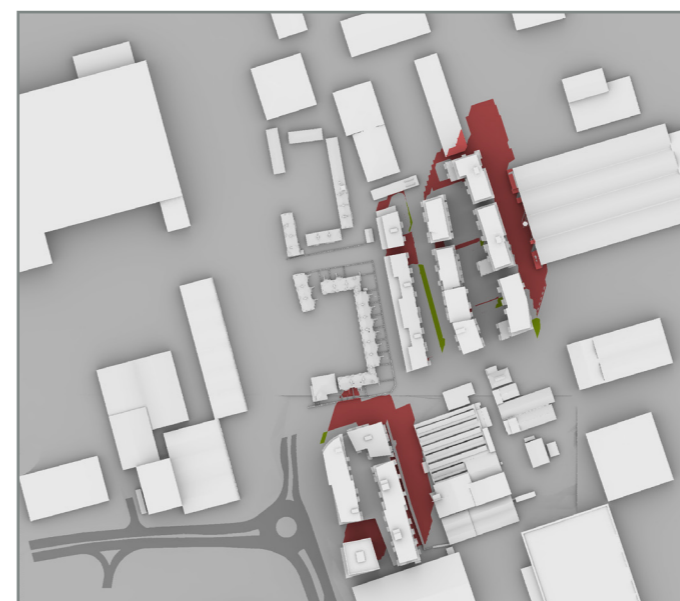
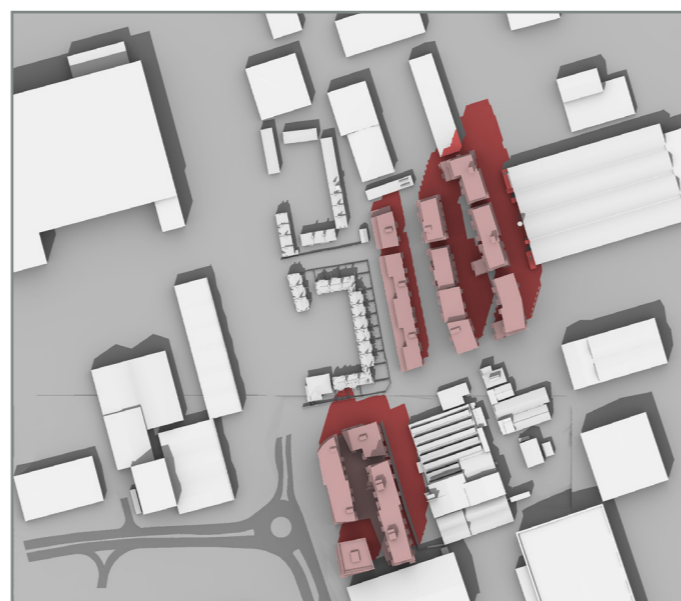

13:00_{GMT}

Existing

Proposed

NORTH



Latitude: 51.4N
Min. solar altitude 10 degrees
(BR209 3.3.8)

Project Charlton Riverside
London

Reference 1864_R35_TS01

Drawn VL Checked PP

Date 29/11/2018 Rel no. 01

Drawing no. 1864_R35_TS01-6

Existing Scenario

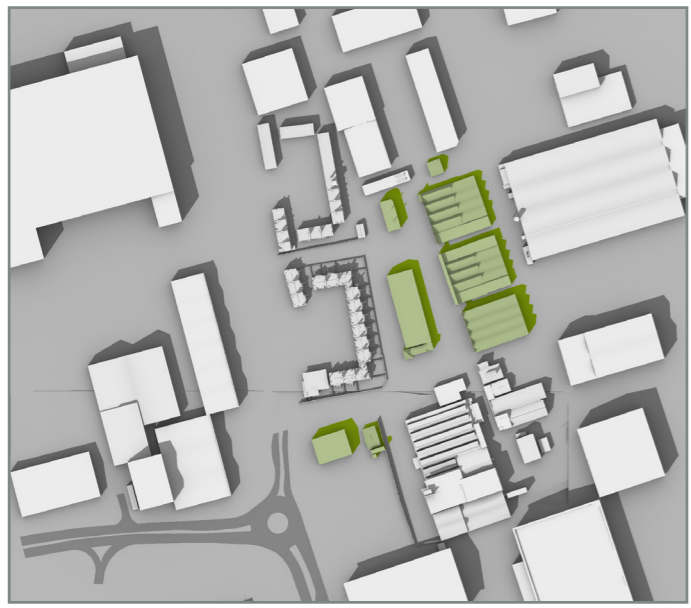

Proposed Scenario

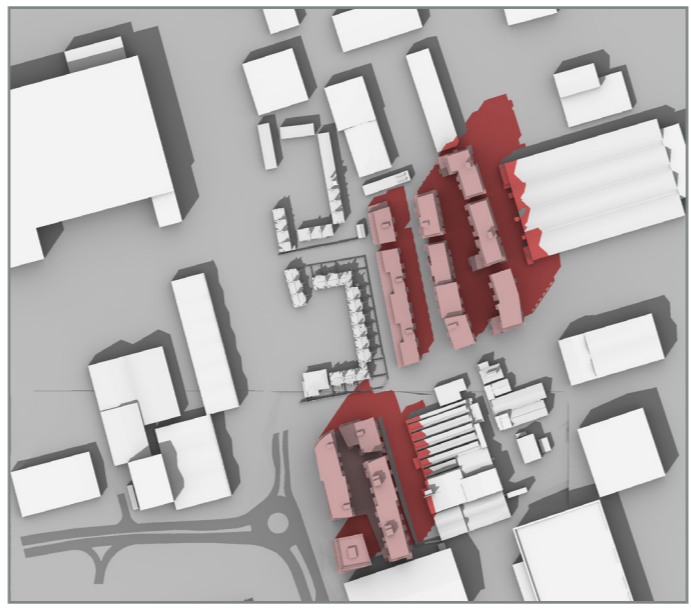

Difference

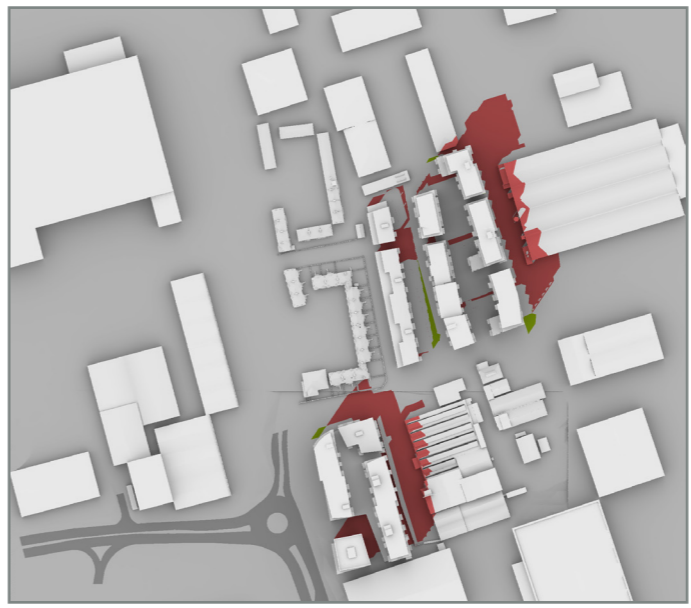

14:00 GMT



Title
 Transient Overshadowing
 Hourly Shadows
 21st March

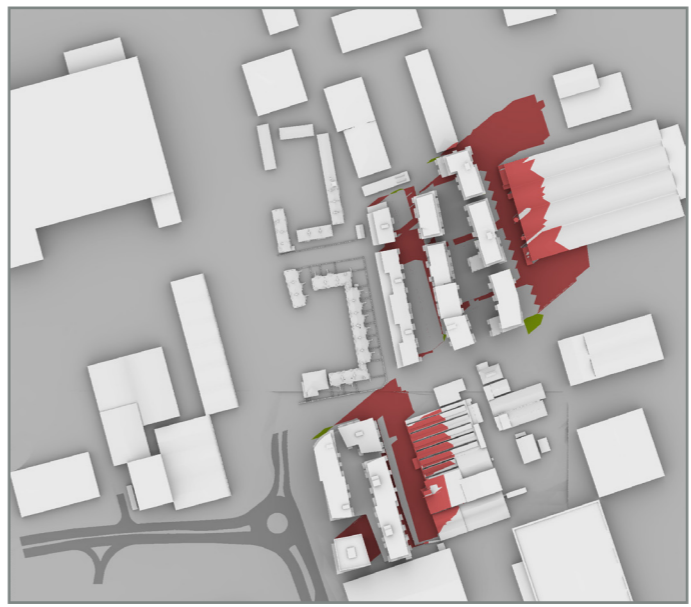
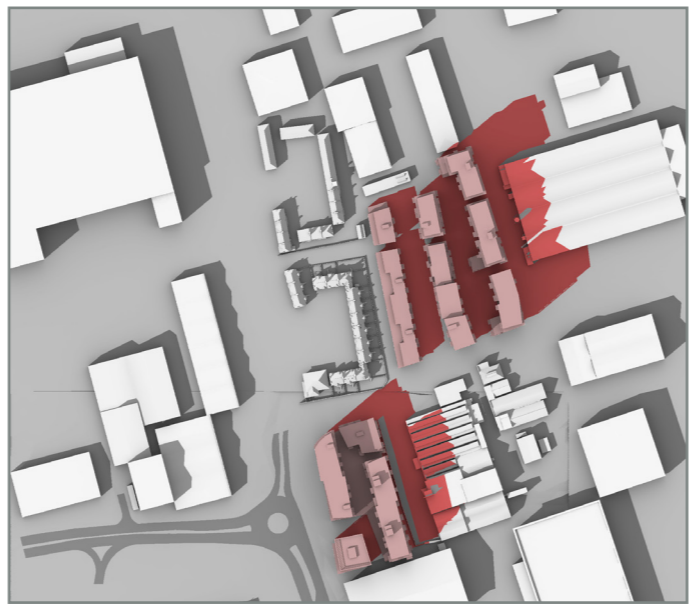

15:00 GMT

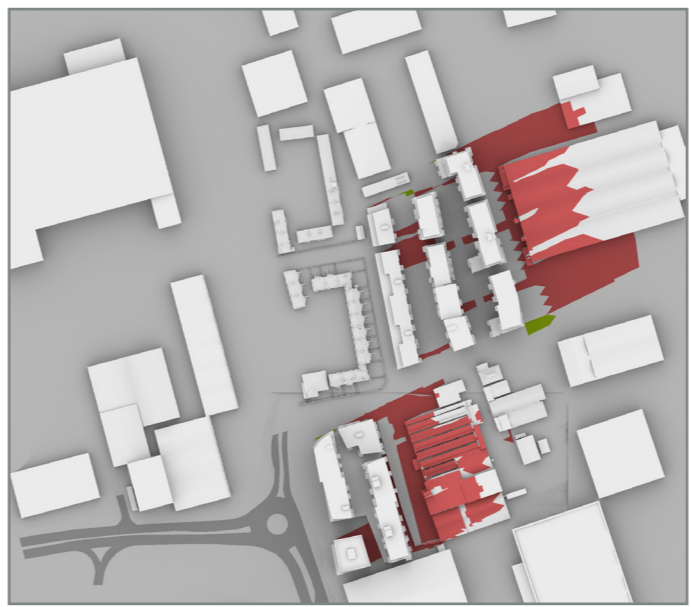
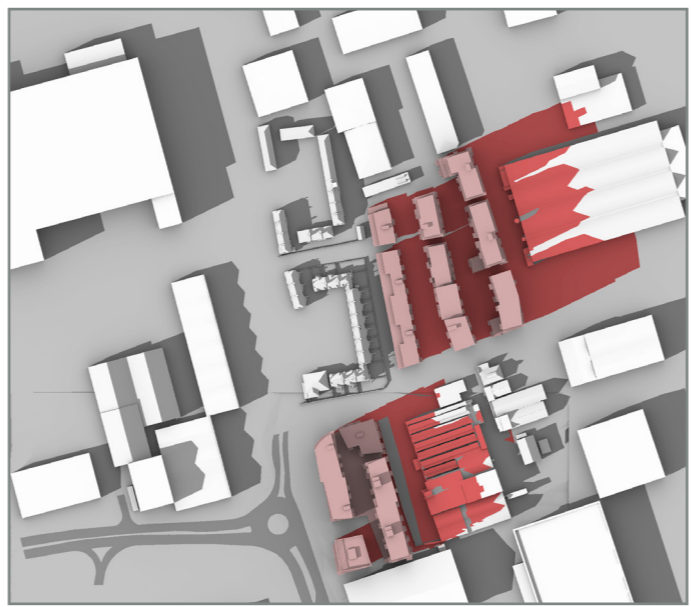

16:00 GMT

Existing

Proposed

NORTH



Latitude: 51.4N
 Min. solar altitude 10 degrees
 (BR209 3.3.8)

Project Charlton Riverside
 London

Reference 1864_R35_TS01

Drawn VL Checked PP

Date 29/11/2018 Rel no. 01

Drawing no. 1864_R35_TS01-7

Existing Scenario

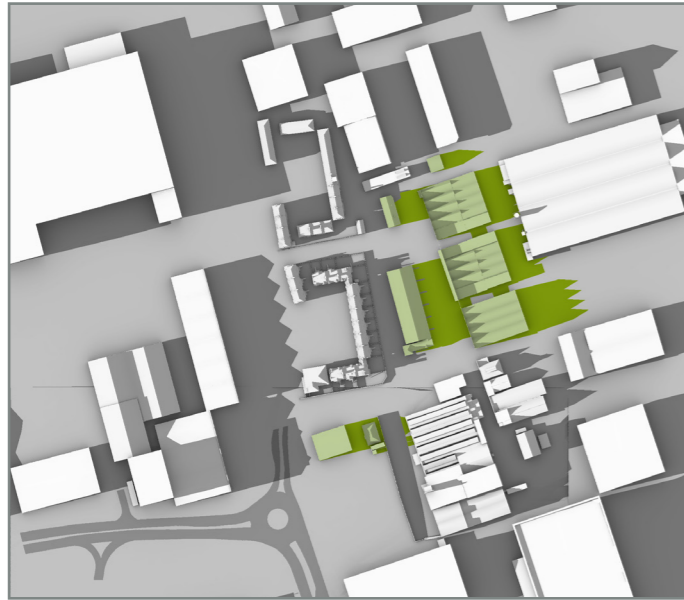

Proposed Scenario

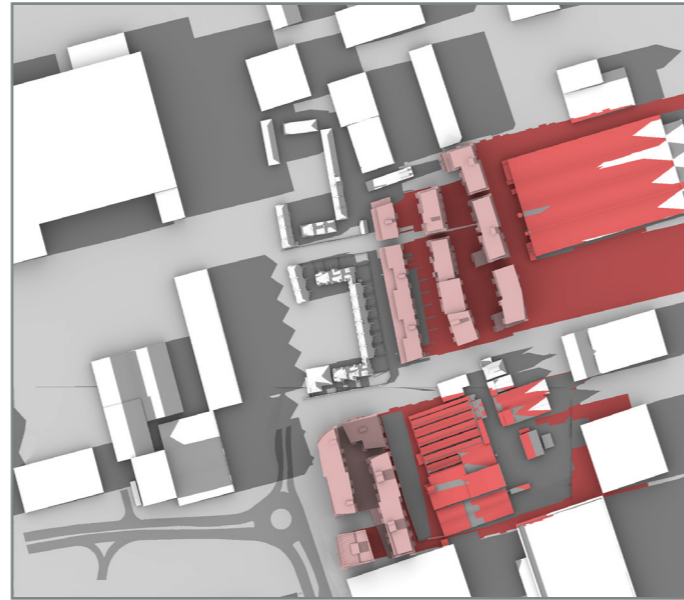

Difference

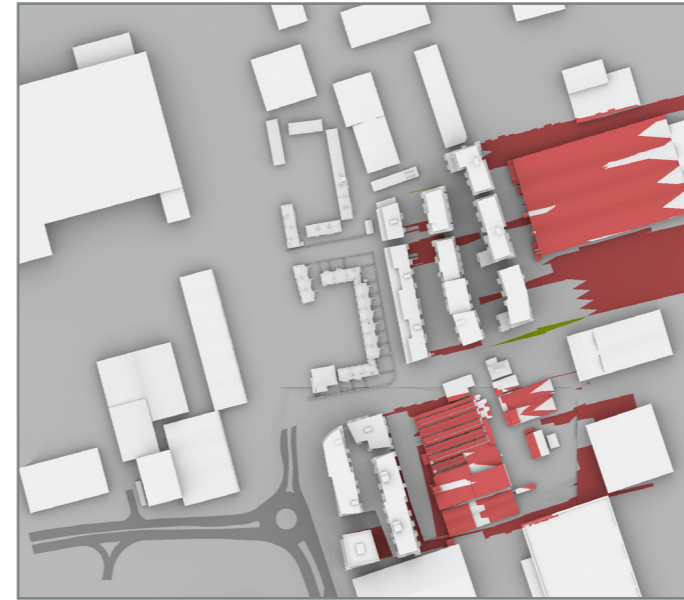

17:00GMT

Title

Transient Overshadowing
Hourly Shadows
21st March

 Existing

 Proposed

NORTH

 Latitude: 51.4N
Min. solar altitude 10 degrees
(BR209 3.3.8)

Project Charlton Riverside
London

Reference 1864_R35_TS01

Drawn VL Checked PP

Date 29/11/2018 Rel no. 01

Drawing no. 1864_R35_TS01-8

Existing Scenario



Proposed Scenario

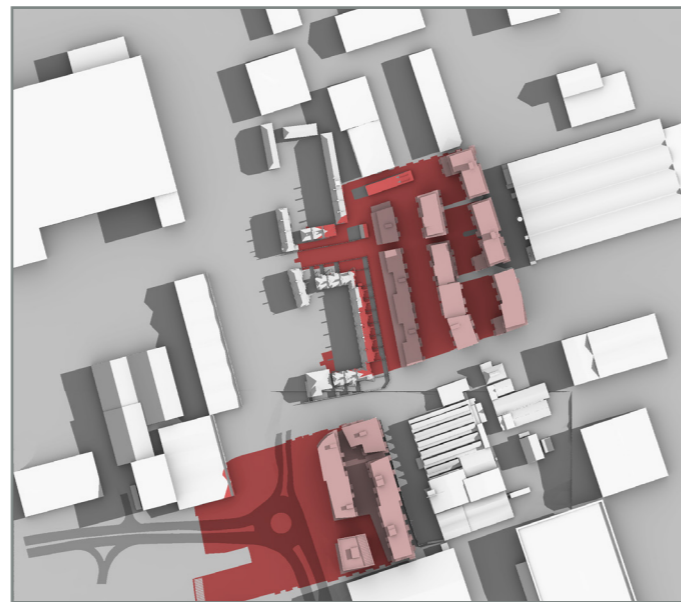

Difference

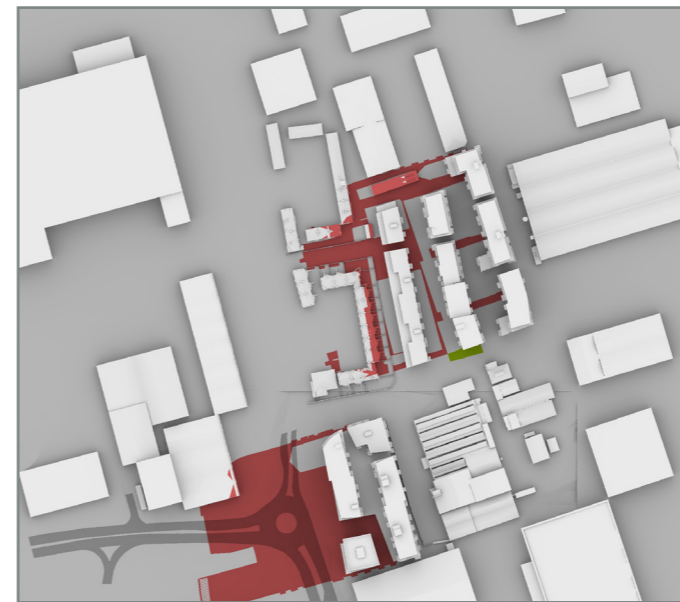

6:00GMT

Title

Transient Overshadowing
Hourly Shadows
21st June

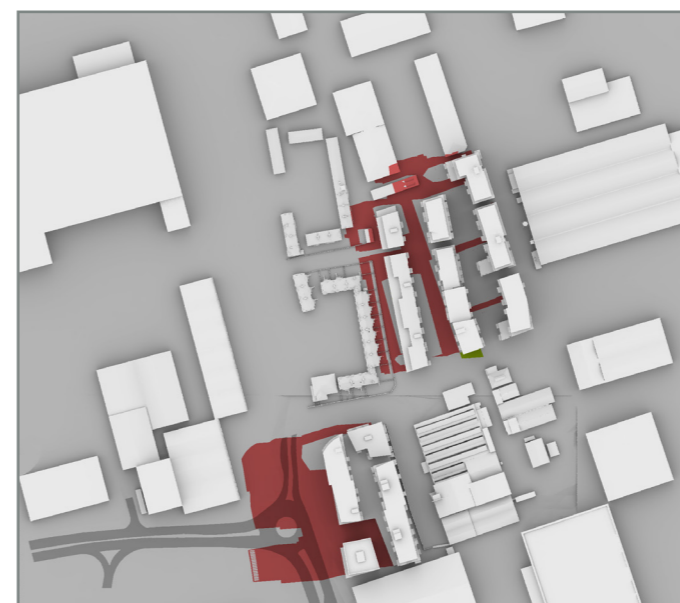

7:00GMT

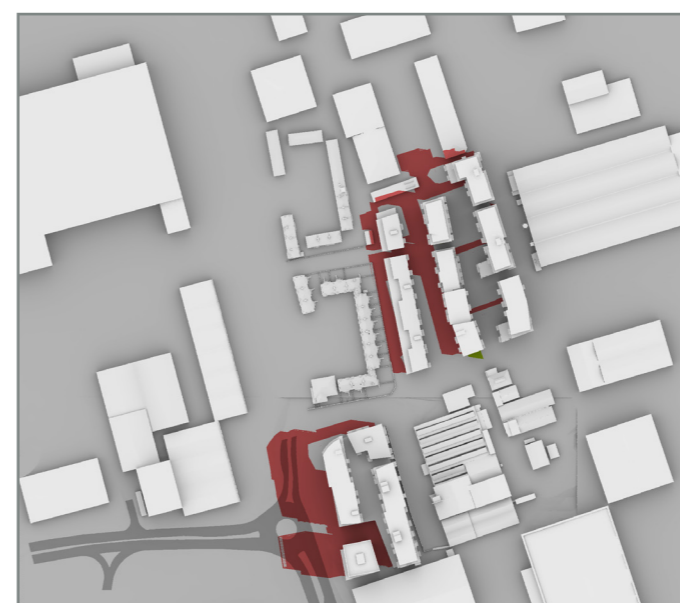
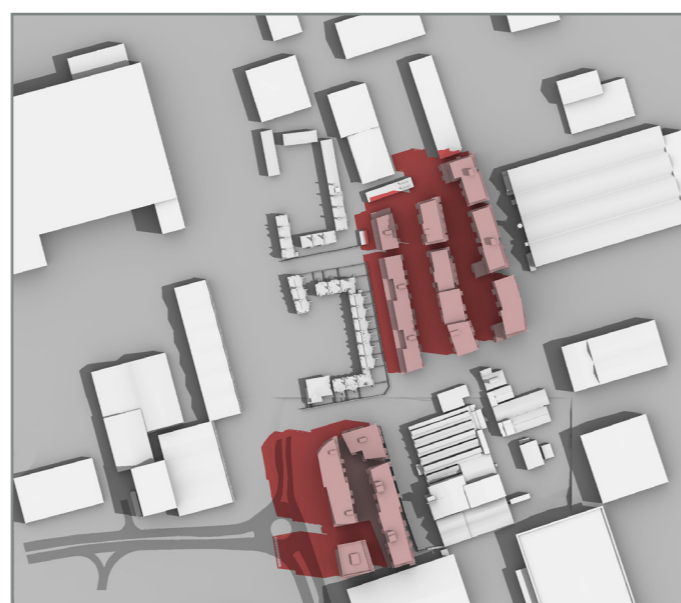

8:00GMT

Existing

Proposed

NORTH



Latitude: 51.4N
Min. solar altitude 10 degrees
(BR209 3.3.8)

Project Charlton Riverside
London

Reference 1864_R35_TS01

Drawn VL Checked PP

Date 29/11/2018 Rel no. 01

Drawing no. 1864_R35_TS01-9

Existing Scenario



Proposed Scenario

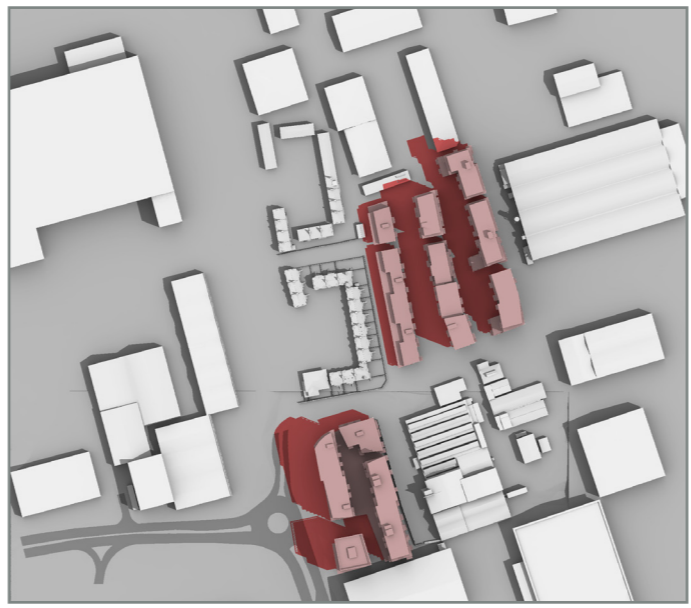

Difference

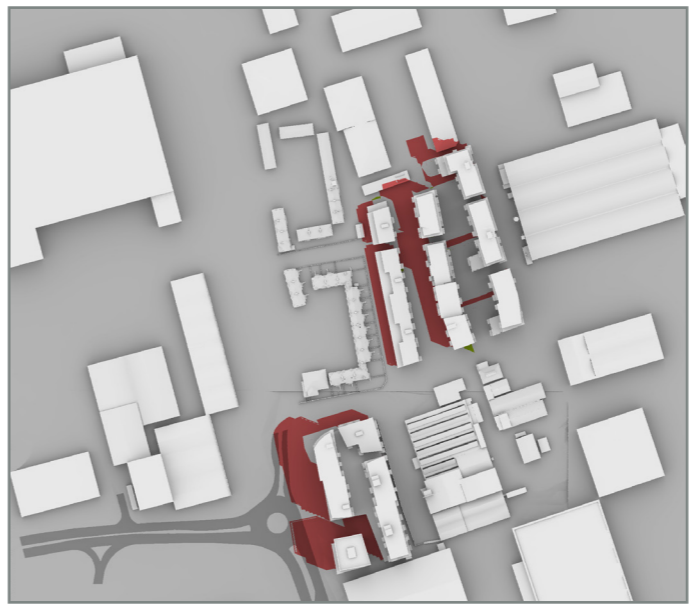

9:00GMT

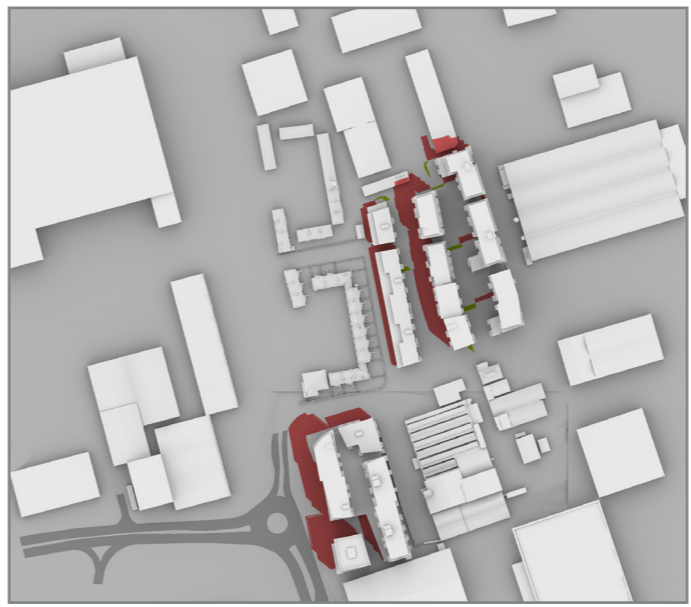
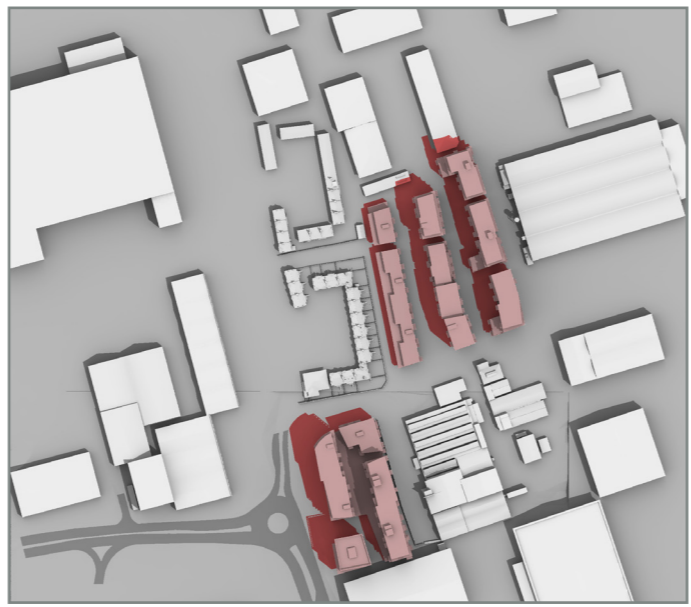

10:00GMT

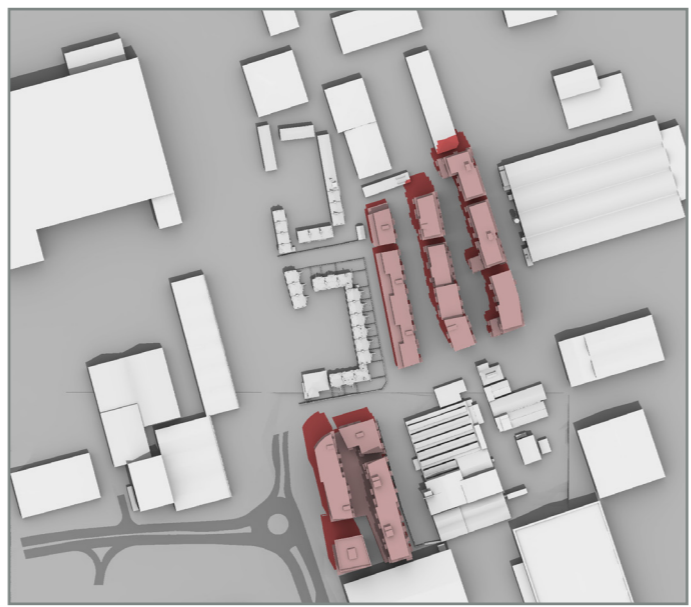

11:00GMT

Title
 Transient Overshadowing
 Hourly Shadows
 21st June

Existing
 Proposed

NORTH

 Latitude: 51.4N
 Min. solar altitude 10 degrees
 (BR209 3.3.8)

Project Charlton Riverside
 London

Reference 1864_R35_TS01

Drawn VL Checked PP

Date 29/11/2018 Rel no. 01

Drawing no. 1864_R35_TS01-10

Existing Scenario



Proposed Scenario

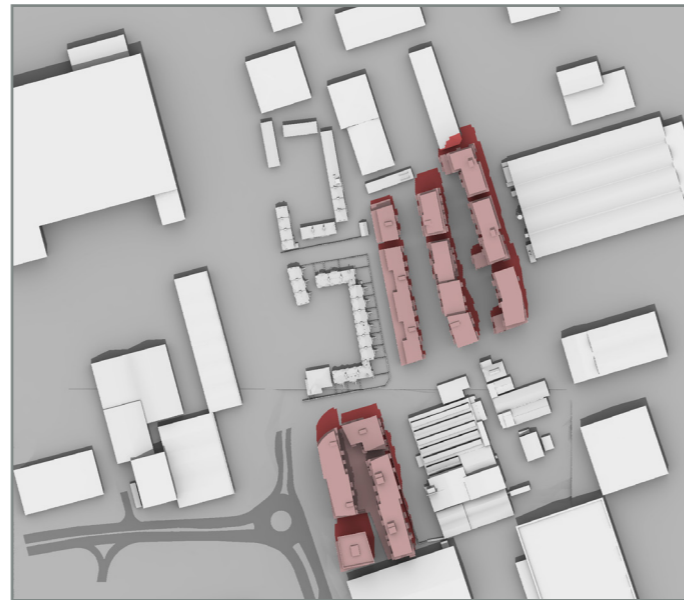

Difference



12:00GMT



Title

Transient Overshadowing
Hourly Shadows
21st June

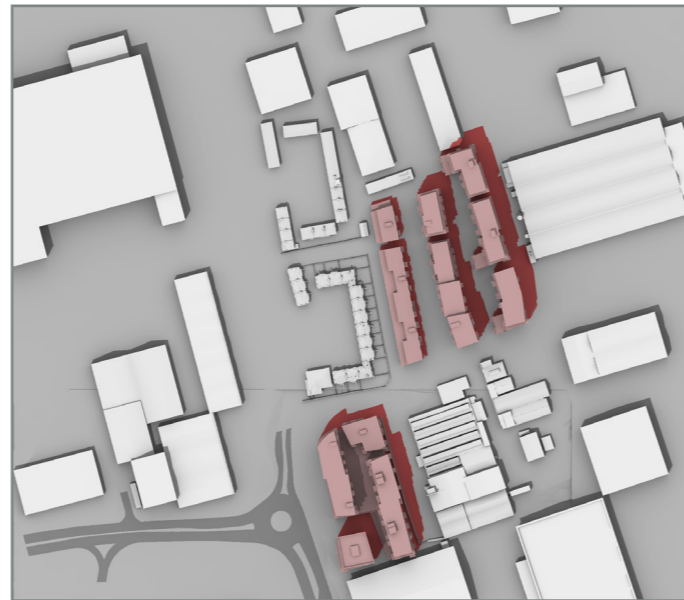

13:00GMT

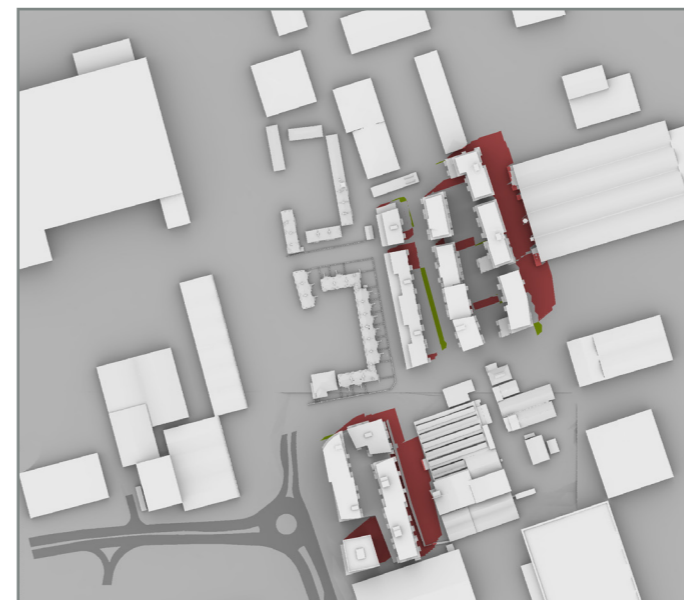
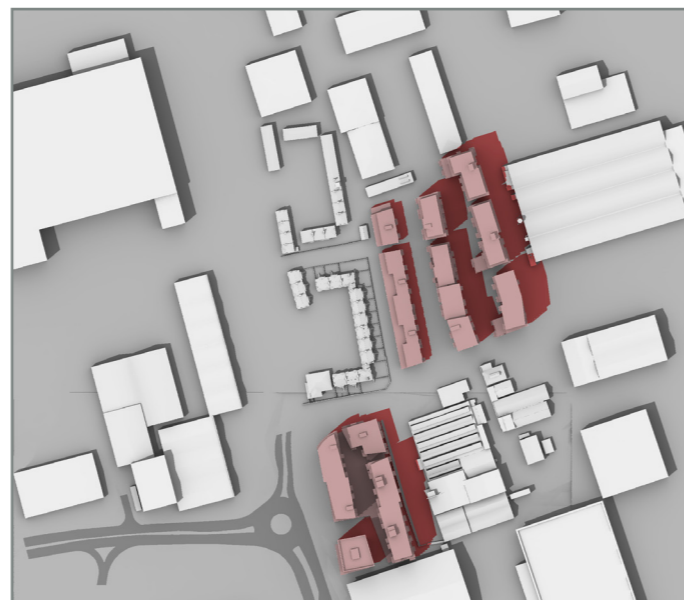

14:00GMT

Existing

Proposed

NORTH



Latitude: 51.4N
Min. solar altitude 10 degrees
(BR209 3.3.8)

Project Charlton Riverside
London

Reference 1864_R35_TS01

Drawn VL Checked PP

Date 29/11/2018 Rel no. 01

Drawing no. 1864_R35_TS01-11

Existing Scenario



Proposed Scenario

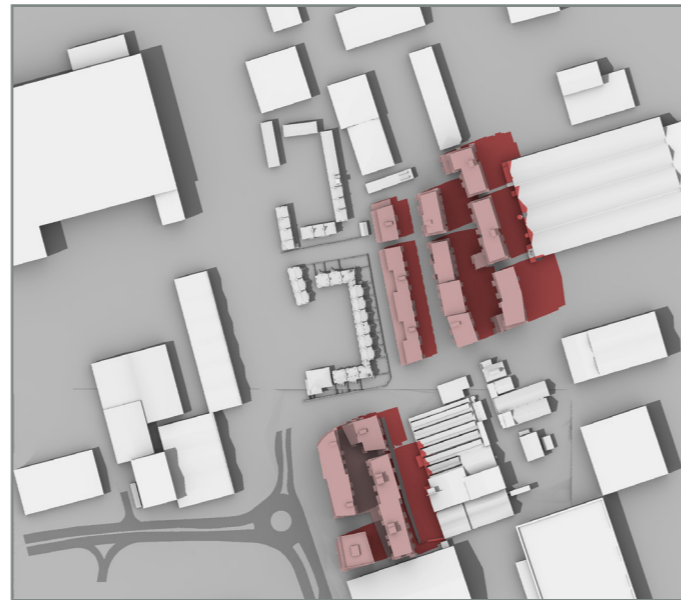

Difference

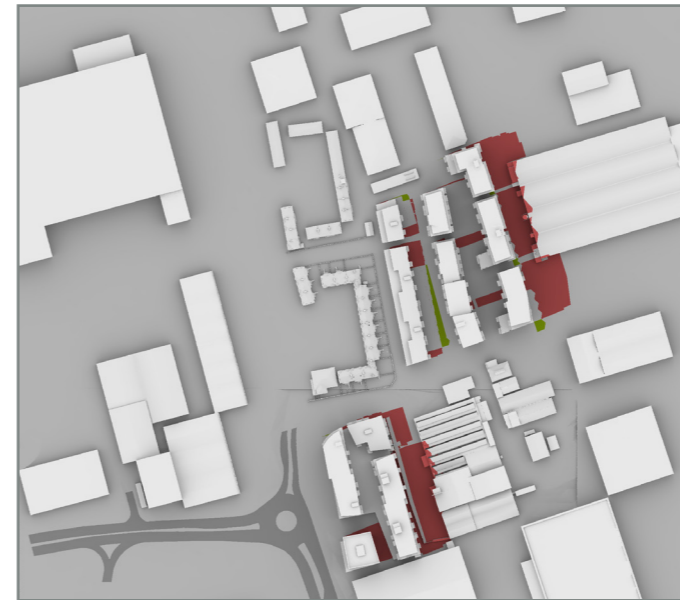

15:00GMT



Title

Transient Overshadowing
Hourly Shadows
21st June

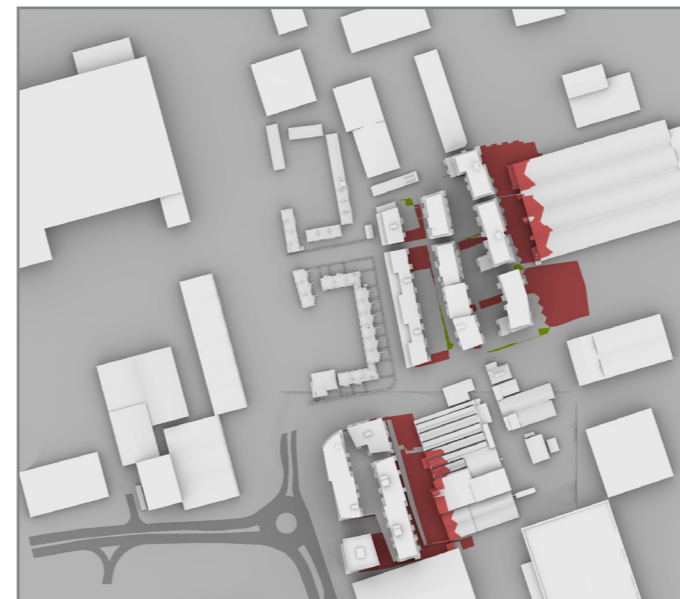
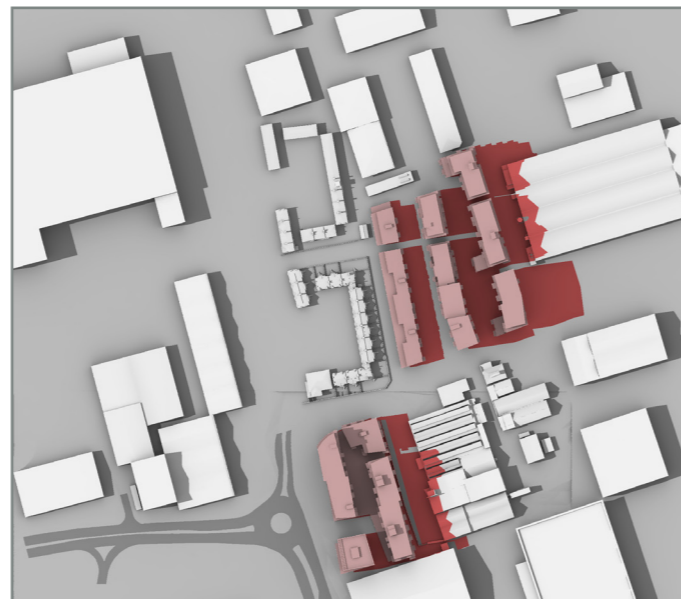

16:00GMT

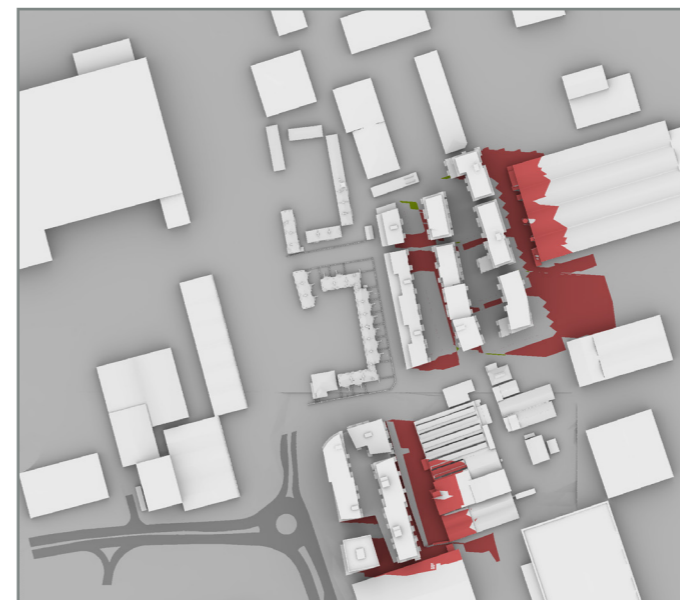
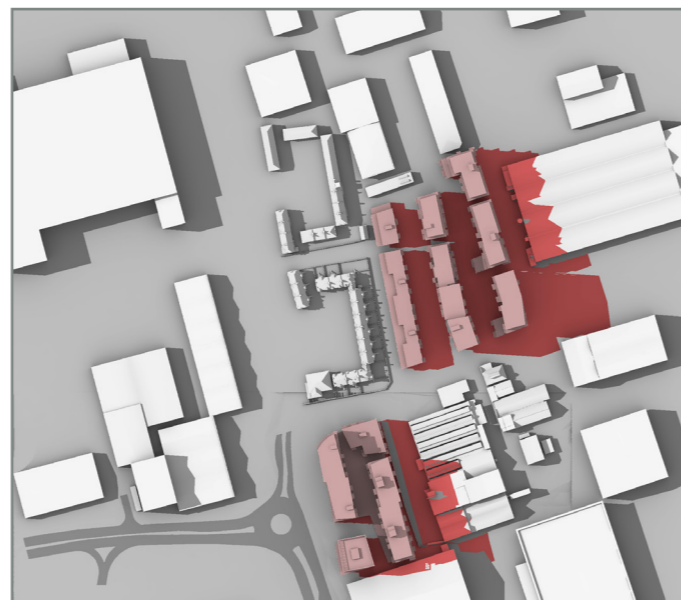

17:00GMT

Existing

Proposed

NORTH



Latitude: 51.4N
Min. solar altitude 10 degrees
(BR209 3.3.8)

Project Charlton Riverside
London

Reference 1864_R35_TS01

Drawn VL Checked PP

Date 29/11/2018 Rel no. 01

Drawing no. 1864_R35_TS01-12

Existing Scenario



Proposed Scenario

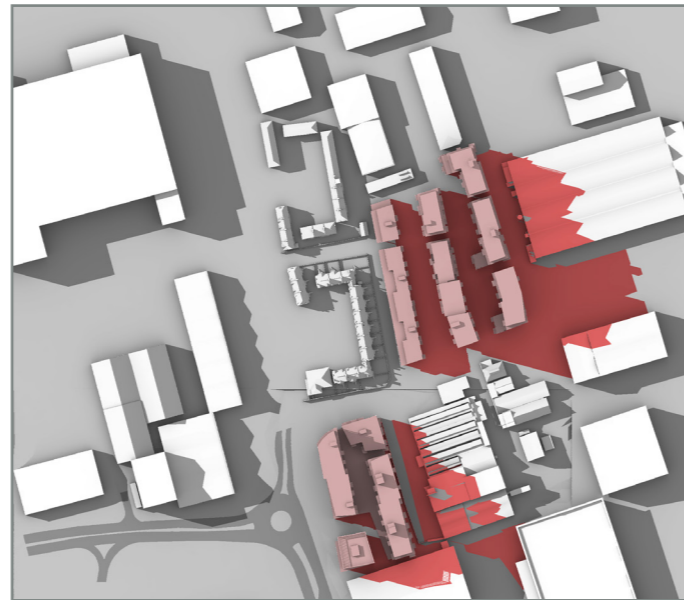

Difference

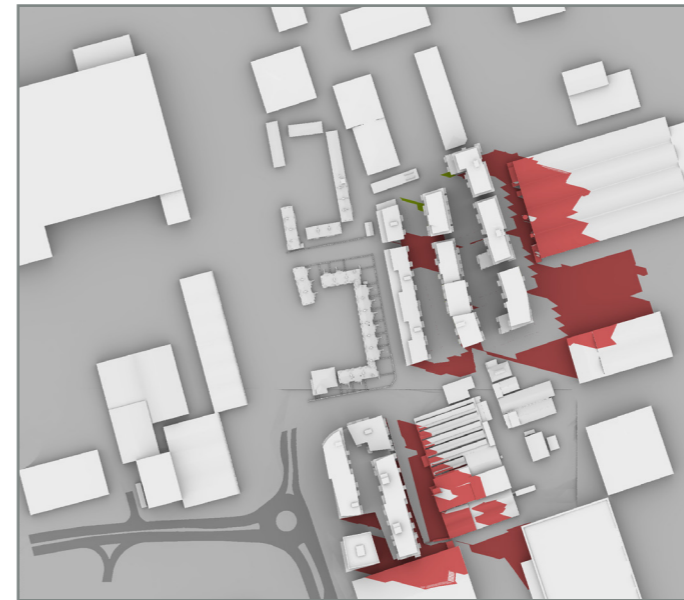

18:00GMT

Title

Transient Overshadowing
Hourly Shadows
21st June

 Existing

 Proposed

NORTH

 Latitude: 51.4N
Min. solar altitude 10 degrees
(BR209 3.3.8)

Project Charlton Riverside
London

Reference 1864_R35_TS01

Drawn VL Checked PP

Date 29/11/2018 Rel no. 01

Drawing no. 1864_R35_TS01-13

Existing Scenario

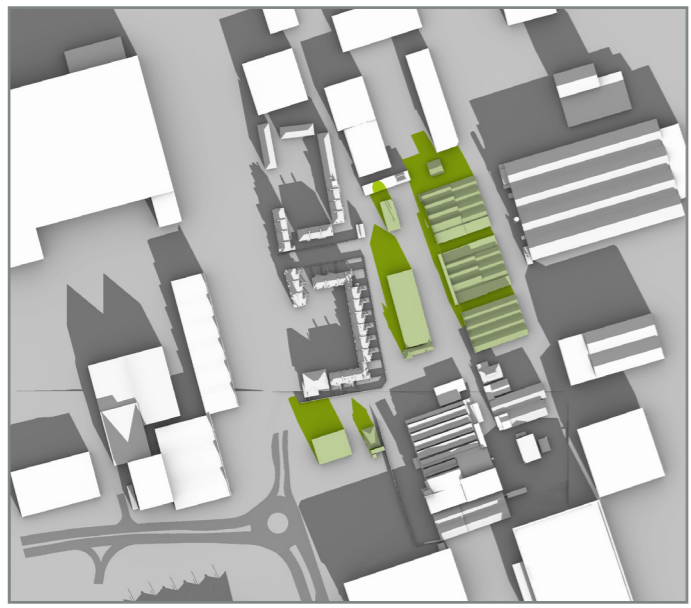

Proposed Scenario

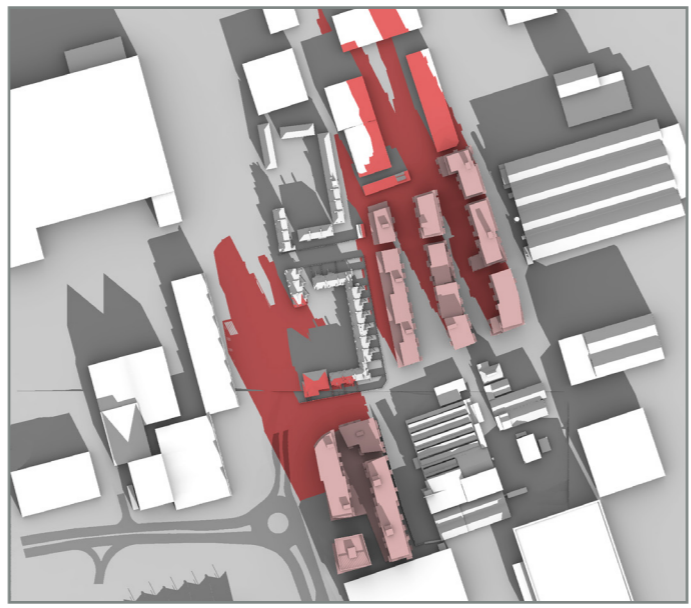

Difference

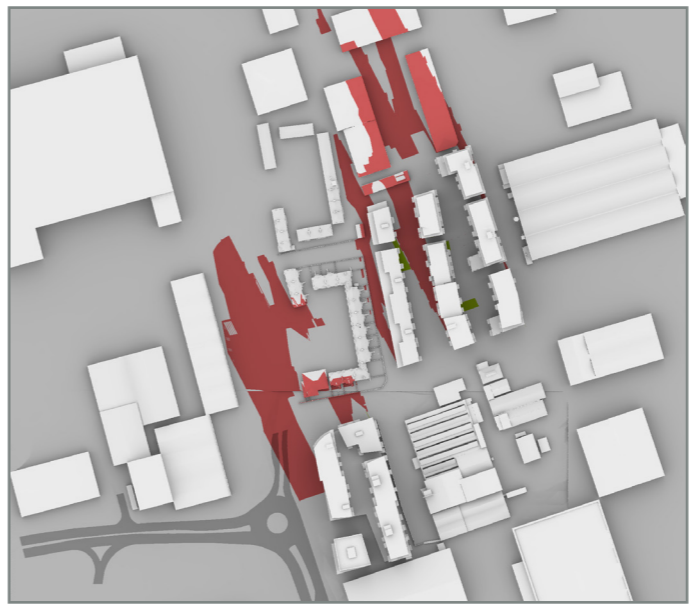

10:00GMT

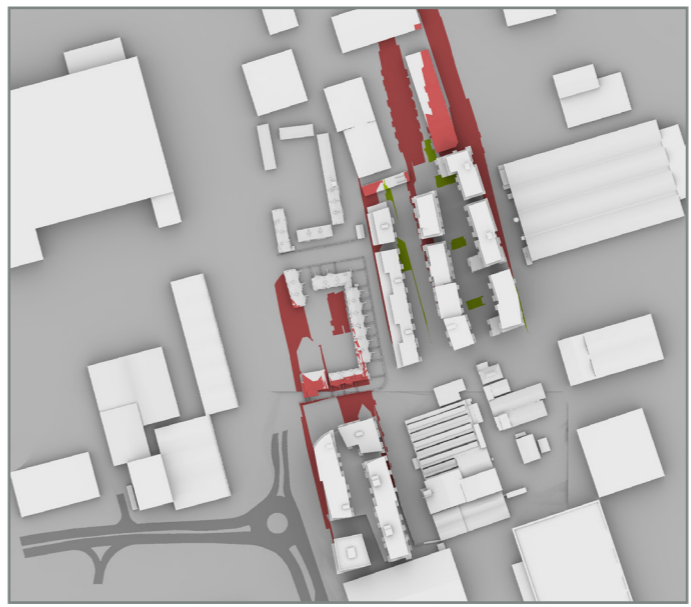
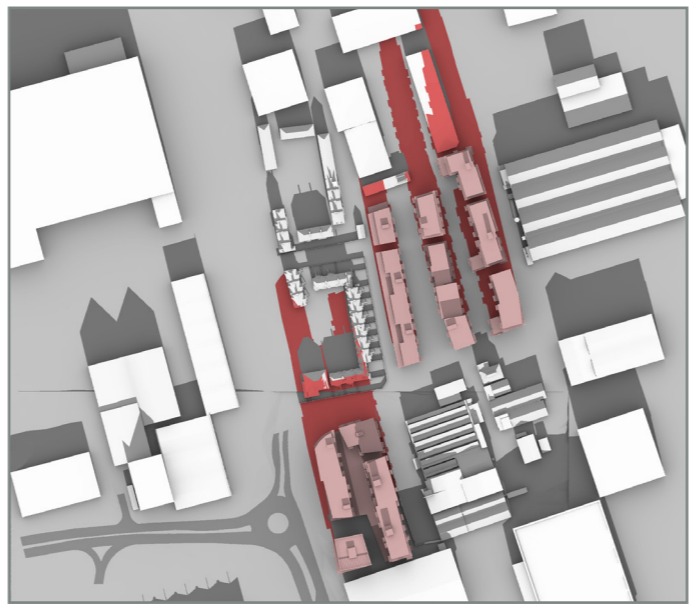

11:00GMT

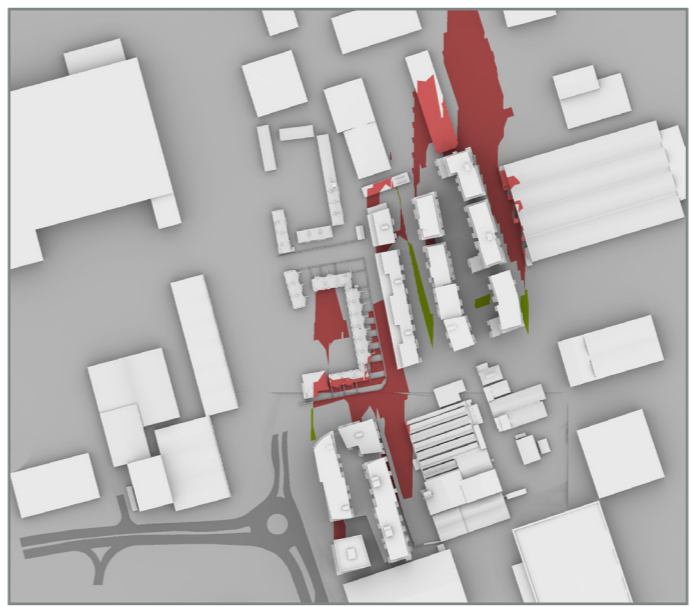
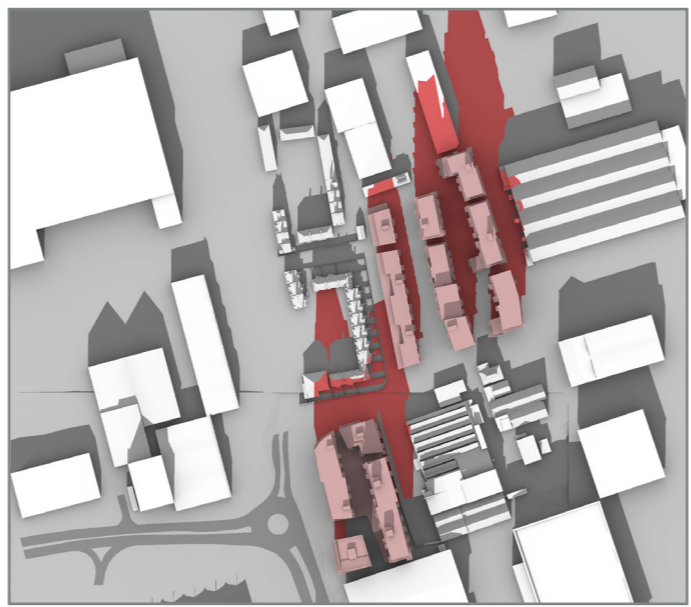
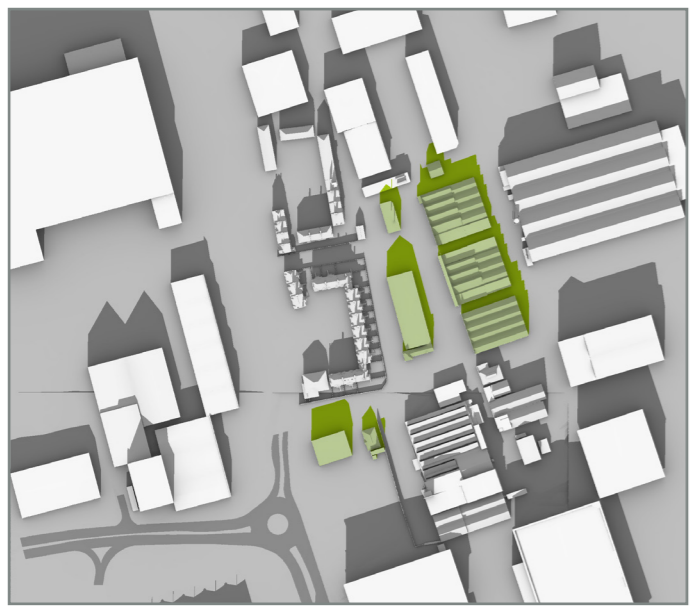

12:00GMT

Title
Transient Overshadowing
Hourly Shadows
21st December

Existing

Proposed

NORTH



Latitude: 51.4N
Min. solar altitude 10 degrees
(BR209 3.3.8)

Project Charlton Riverside
London

Reference 1864_R35_TS01

Drawn VL Checked PP

Date 29/11/2018 Rel no. 01

Drawing no. 1864_R35_TS01-14

Existing Scenario

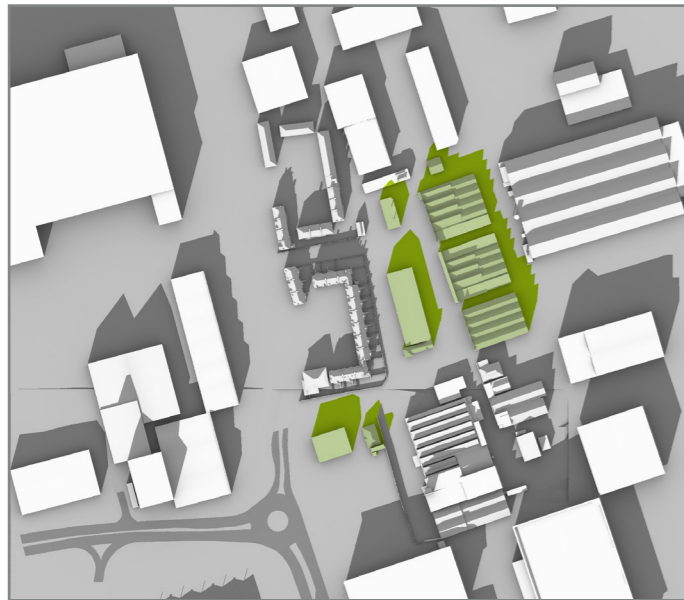

Proposed Scenario

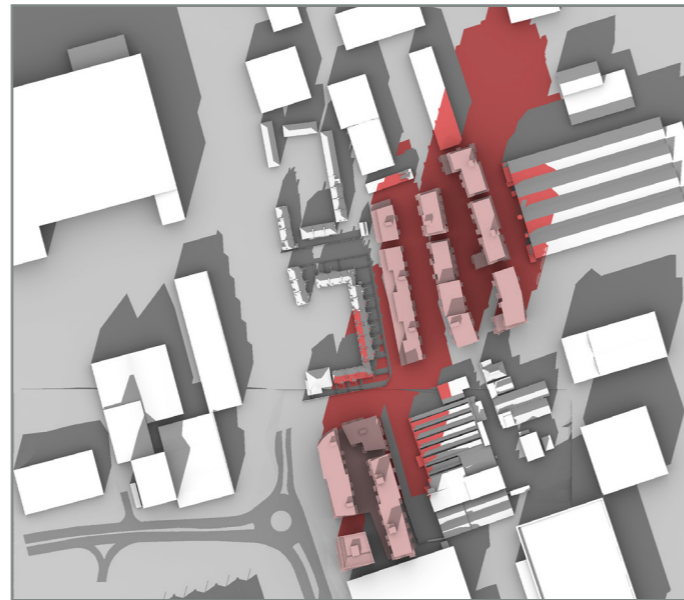

Difference

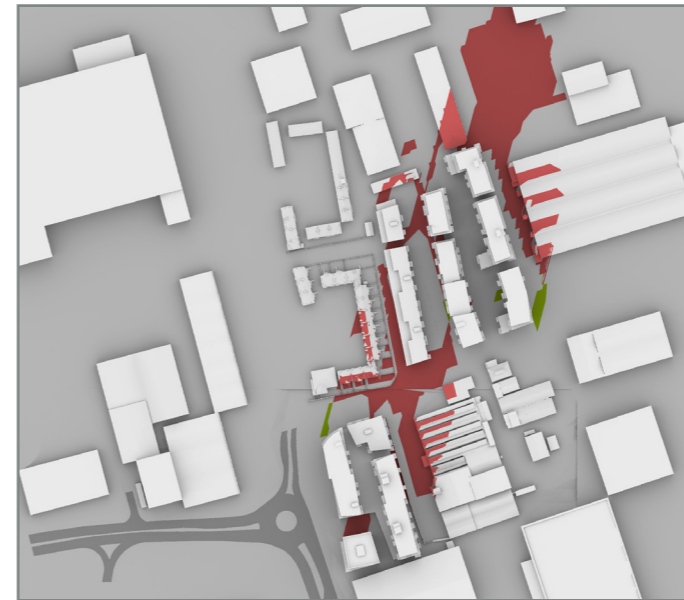

13:00GMT



Title

Transient Overshadowing
Hourly Shadows
21st December

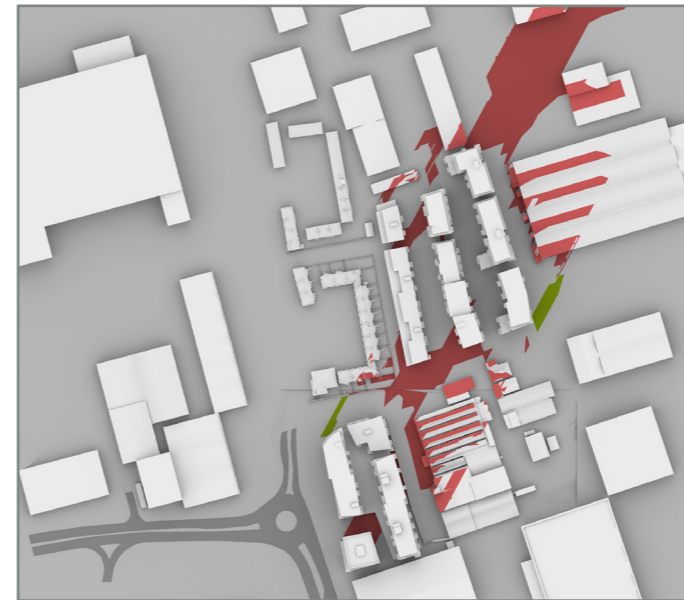
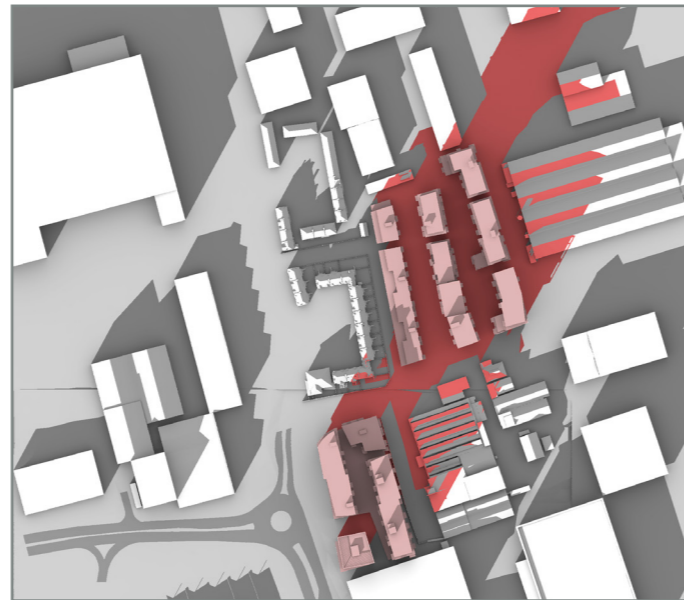
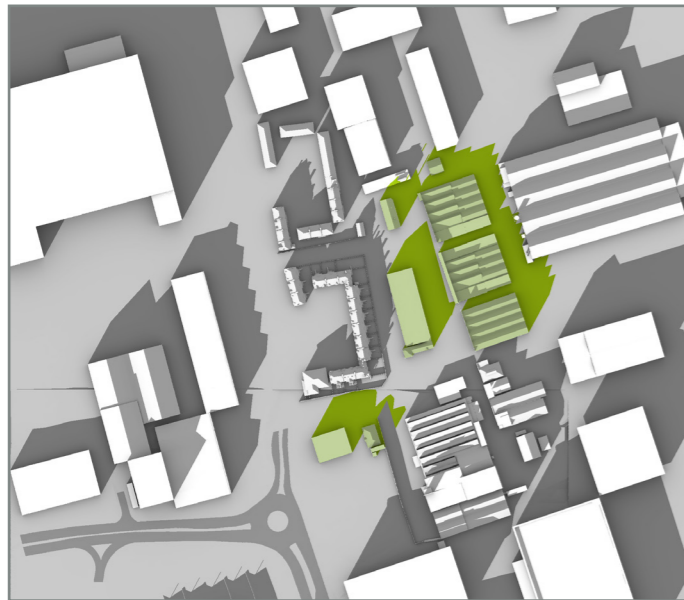

14:00GMT

 Existing

 Proposed

NORTH

 Latitude: 51.4N
Min. solar altitude 10 degrees
(BR209 3.3.8)

Project Charlton Riverside
London

Reference 1864_R35_TS01

Drawn VL Checked PP

Date 29/11/2018 Rel no. 01

Drawing no. 1864_R35_TS01-15



Appendix 11.5A

Solar glare assessment

Title

Reflected Solar Glare
 Site Overview and
 Viewpoint Location
 Proposed Scenario

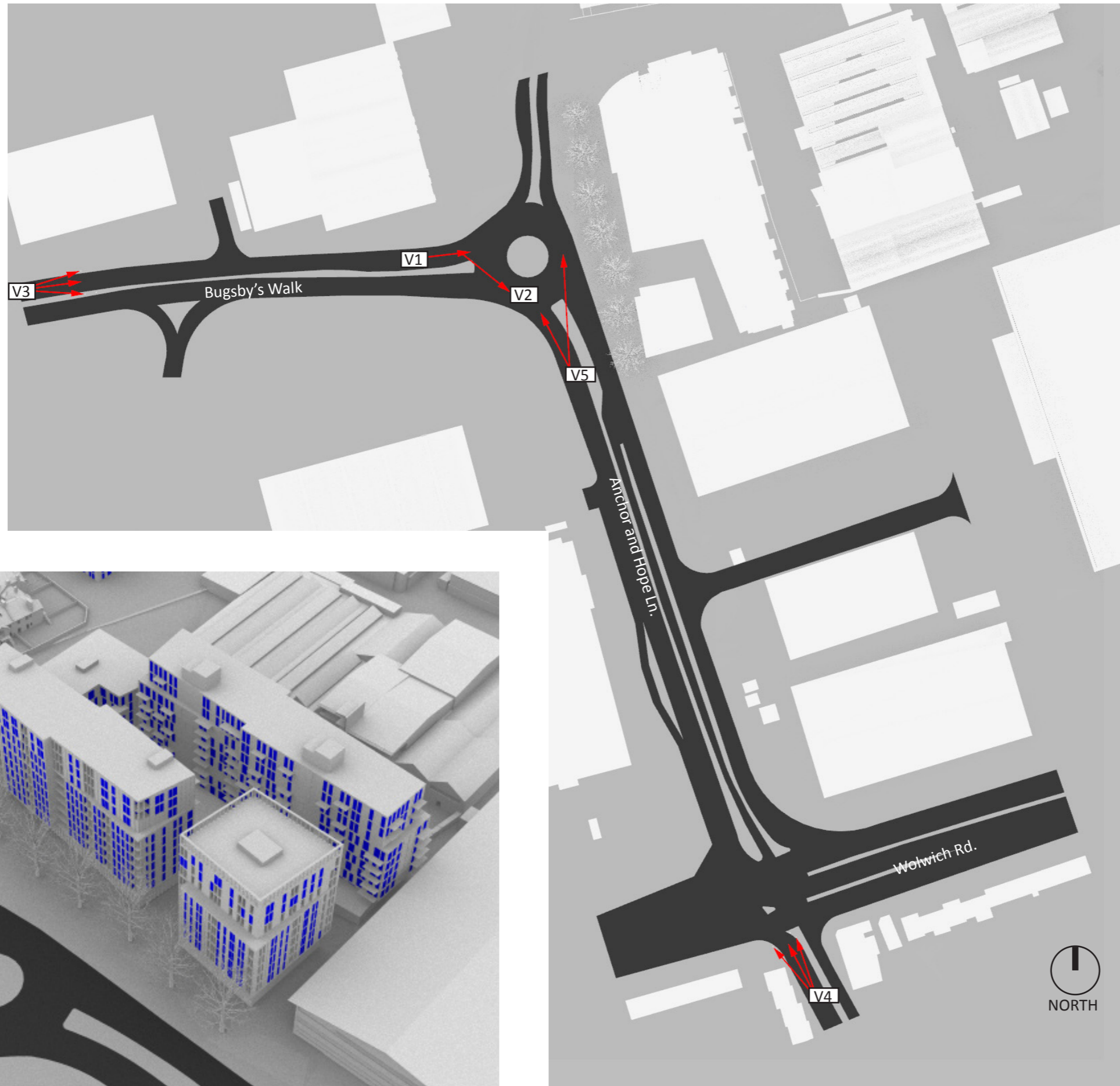

Fig. 1: Perspective

Fig. 2: View points

Project Charlton Riverside
 Greenwich

Reference 1864_R35_SG01

Drawn VL Checked JB

Date 29/11/2018 Rel no. 01

Drawing no. 1864_R35_SG01-1

Title
 Reflected Solar Glare
 Frequency of Solar Reflections
 Proposed Scenario
 Bare trees
 Viewpoint V1A

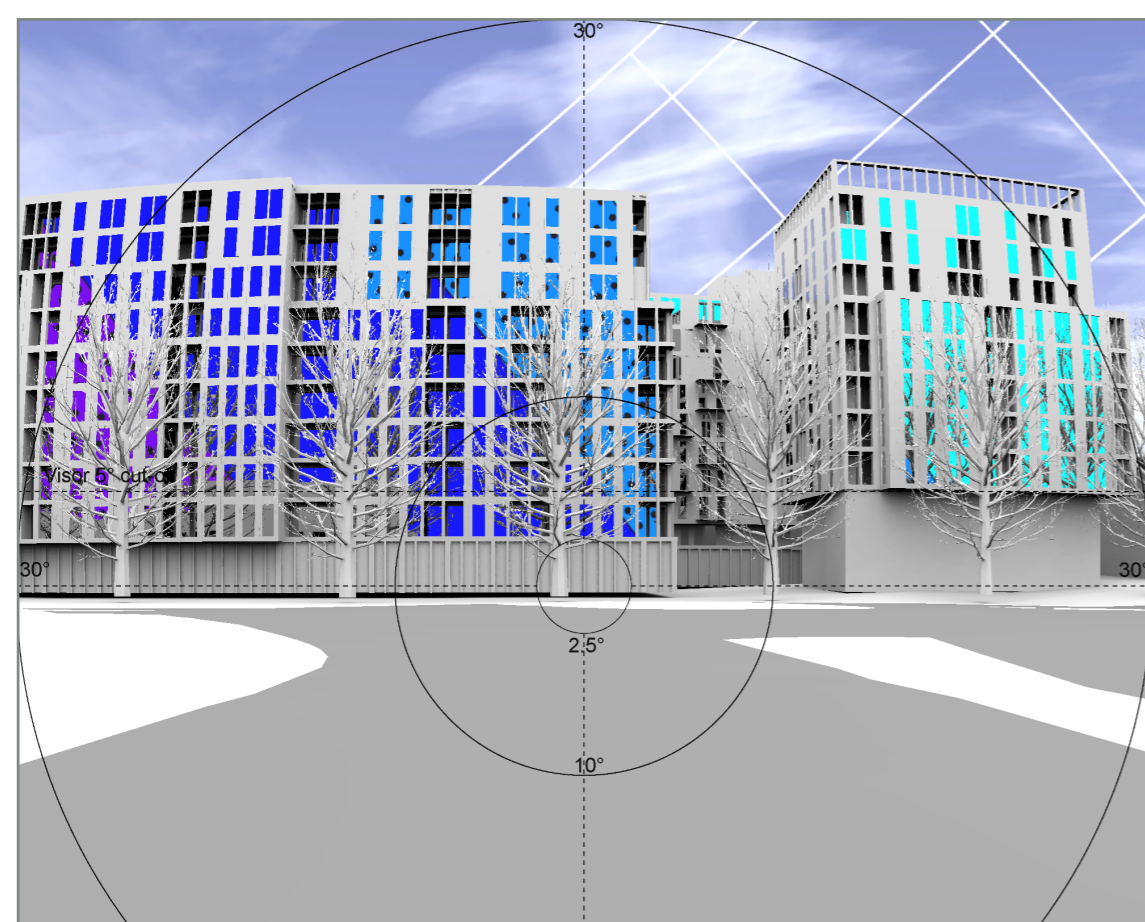

Fig. 3: Solar Glare - HOURS - Close-up

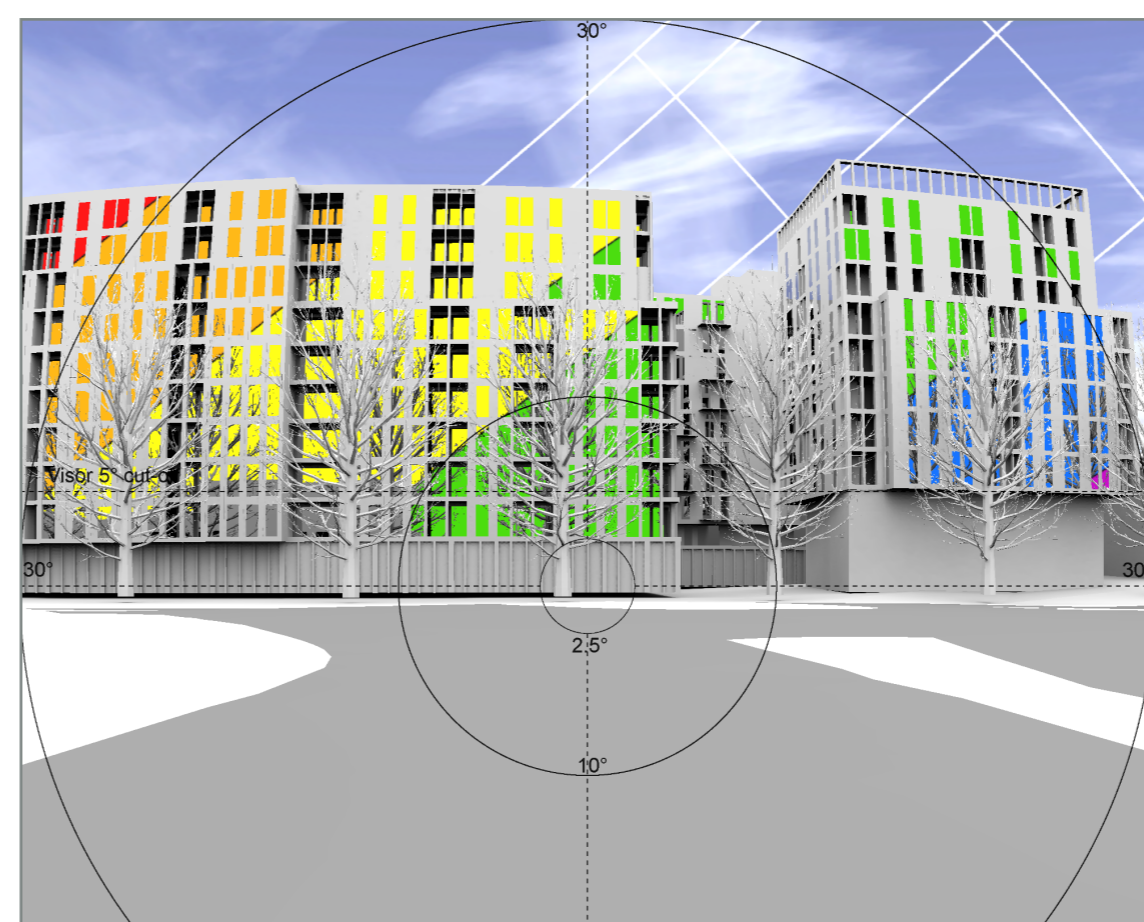
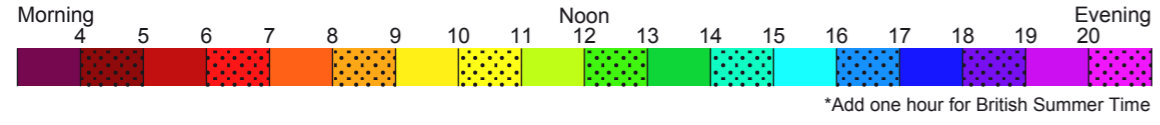

Fig. 4: Solar Glare - MONTHS - Close-up

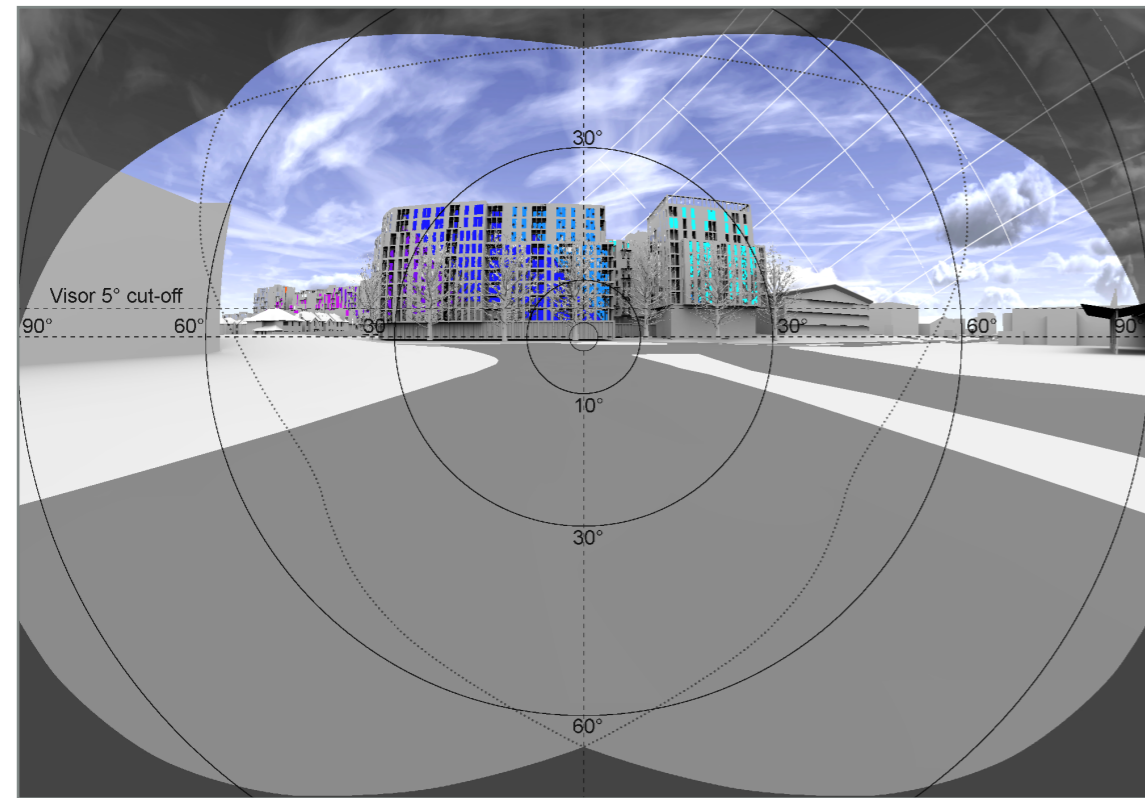
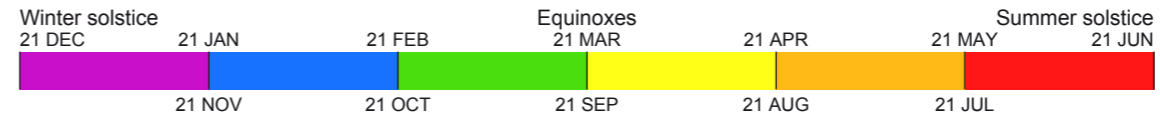

Fig. 5: Solar Glare - HOURS - 180 degrees view

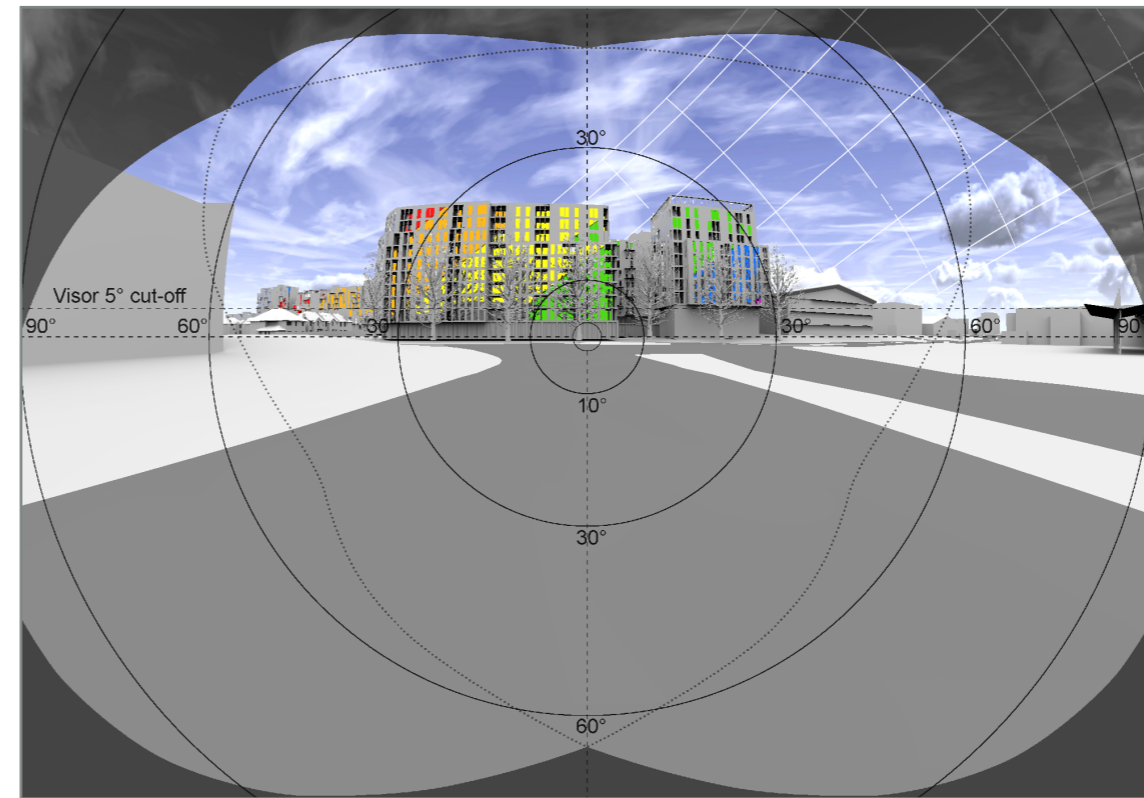

Fig. 6: Solar Glare - MONTHS - 180 degrees view

Project	Charlton Riverside Greenwich		
Reference	1864_R35_SG01		
Drawn	VL	Checked	JB
Date	29/11/2018	Rel no.	01
Drawing no.	1864_R35_SG01-2		

Title
 Reflected Solar Glare
 Frequency of Solar Reflections
 Proposed Scenario
 Trees in leaf
 Viewpoint V1A

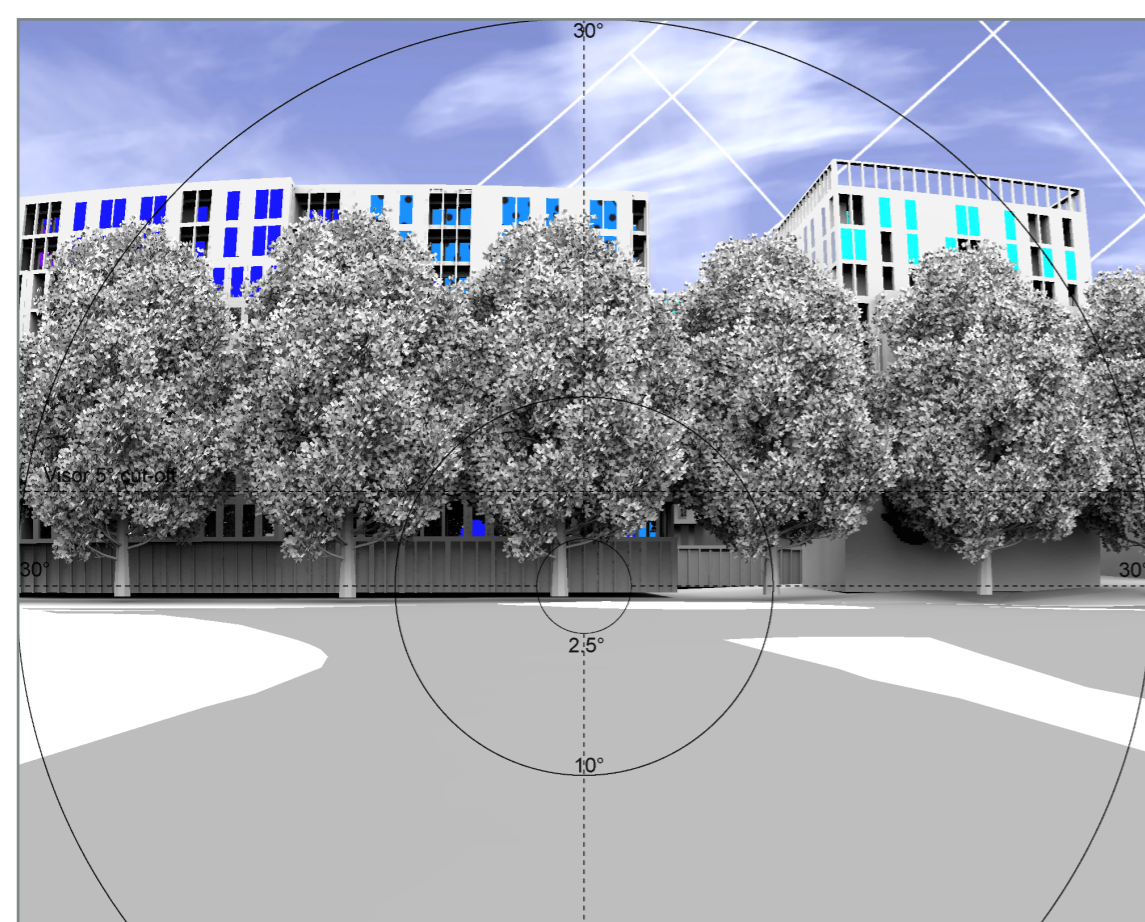

Fig. 7: Solar Glare - HOURS - Close-up

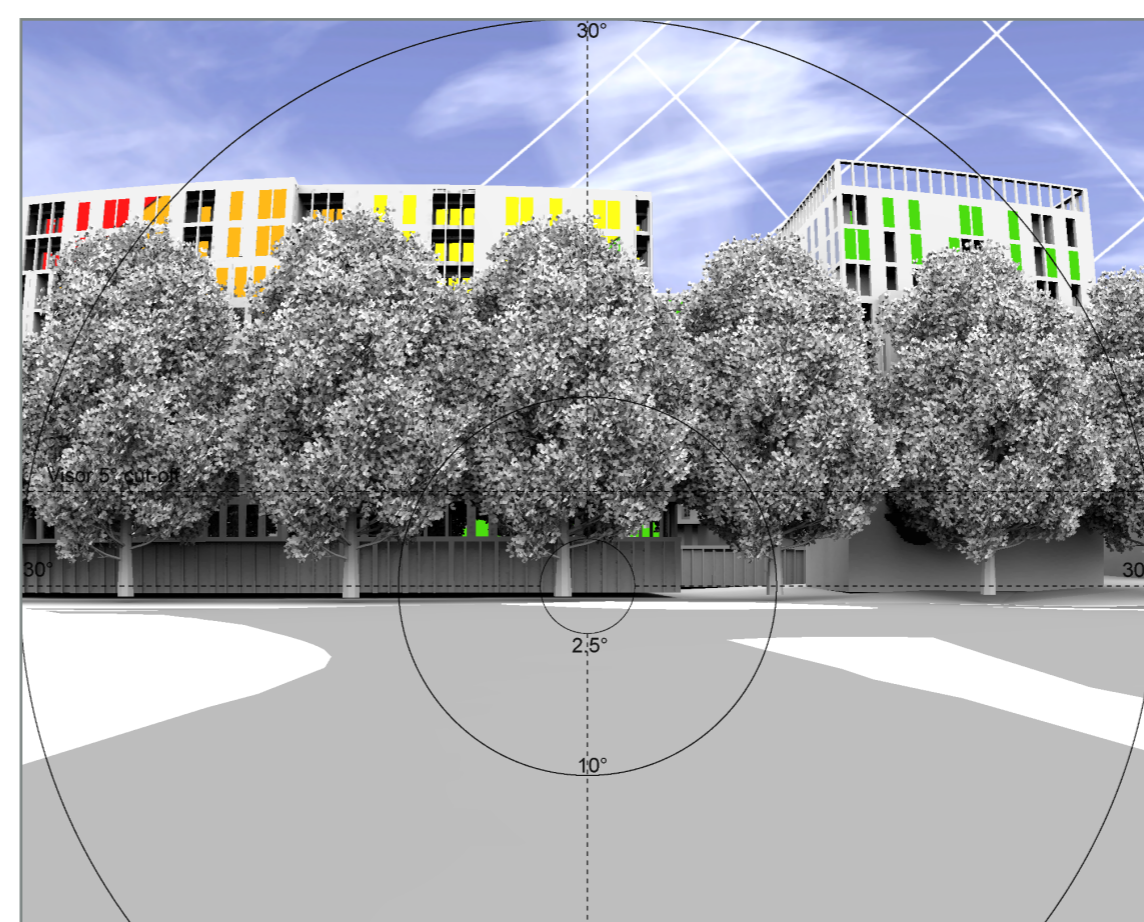
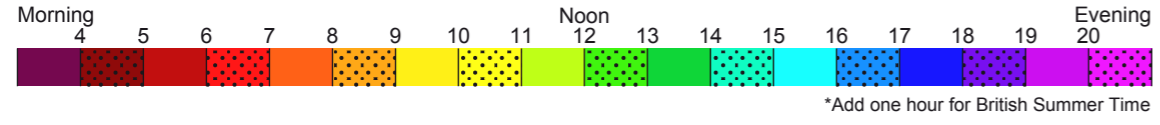

Fig. 8: Solar Glare - MONTHS - Close-up

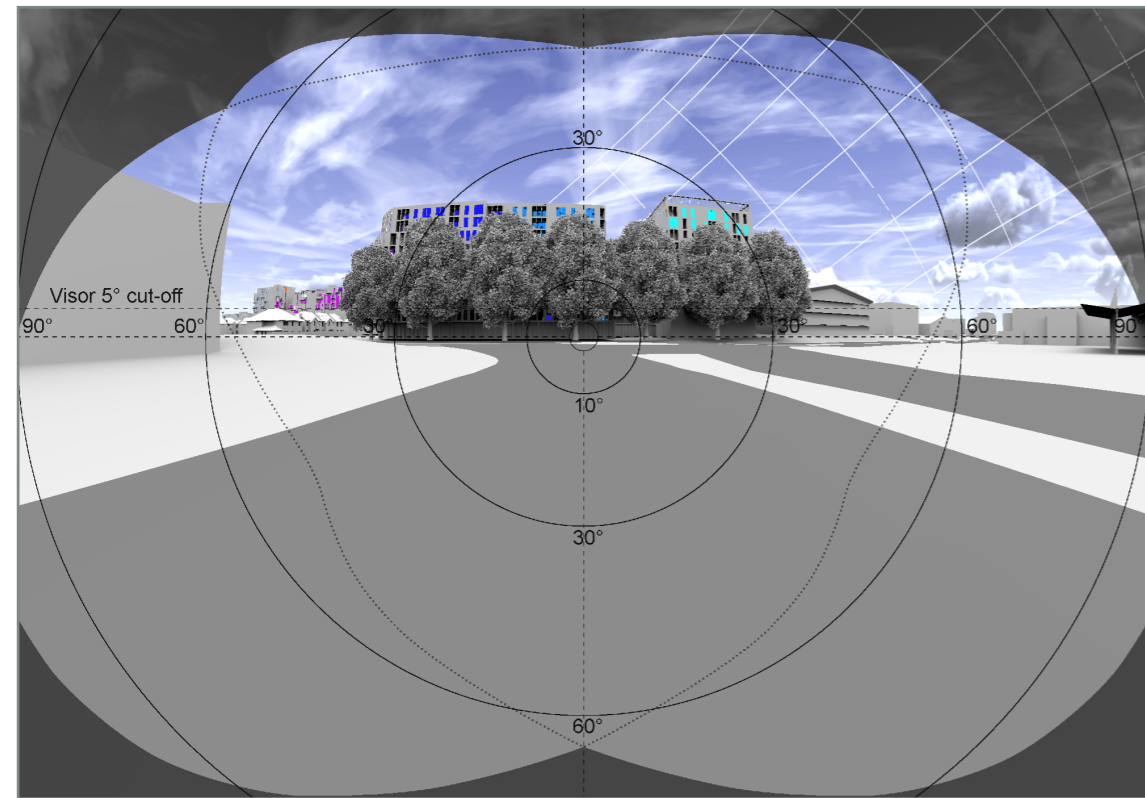
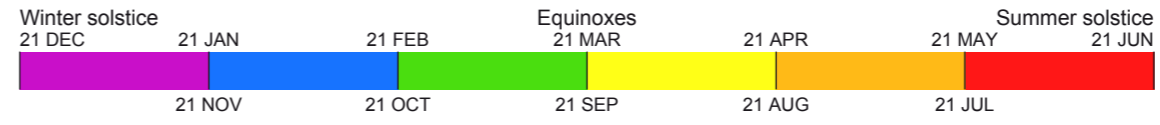

Fig. 9: Solar Glare - HOURS - 180 degrees view

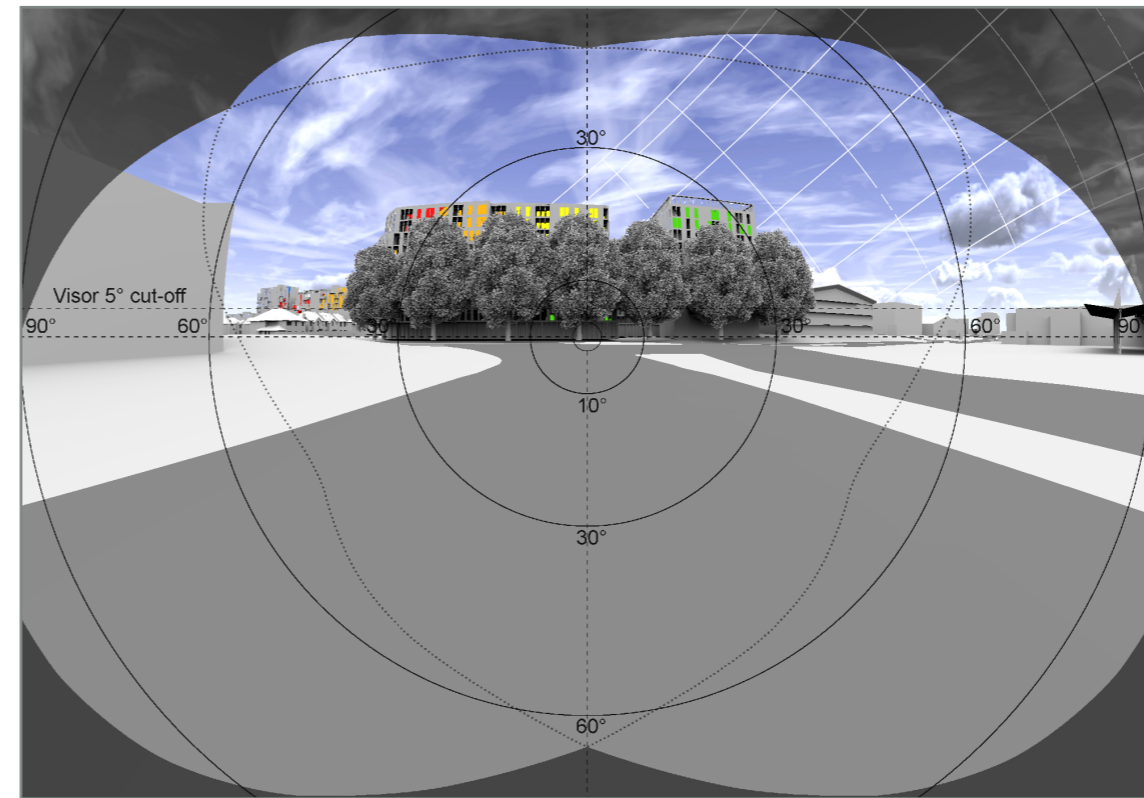

Fig. 10: Solar Glare - MONTHS - 180 degrees view

Project	Charlton Riverside Greenwich		
Reference	1864_R35_SG01		
Drawn	VL	Checked	JB
Date	29/11/2018	Rel no.	01
Drawing no.	1864_R35_SG01-3		

Title
 Reflected Solar Glare
 Frequency of Solar Reflections
 Existing Scenario
 Bare trees
 Viewpoint V1A

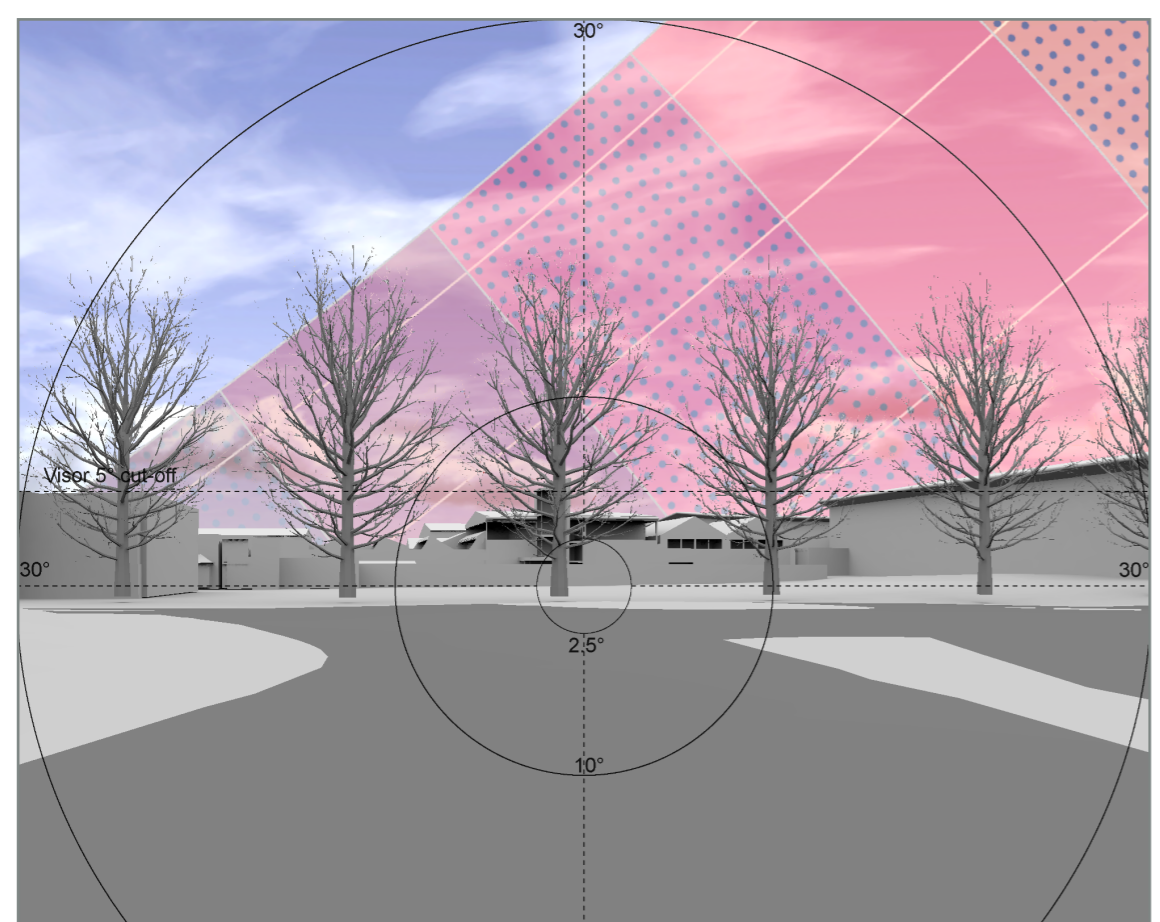

Fig. 11: Solar Glare - HOURS - Close-up

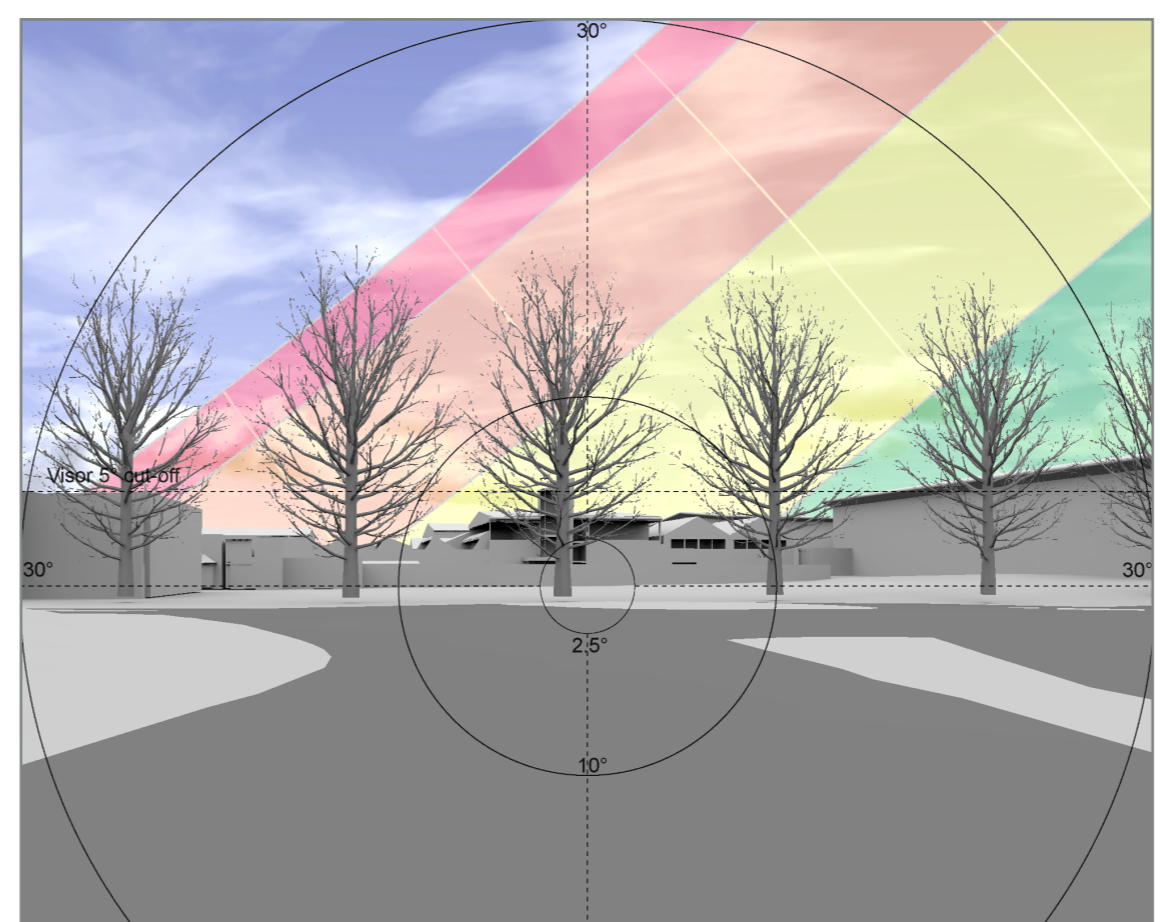
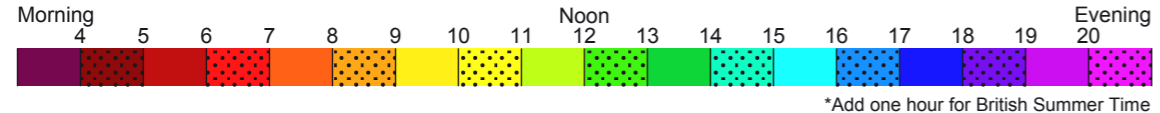

Fig. 12: Solar Glare - MONTHS - Close-up

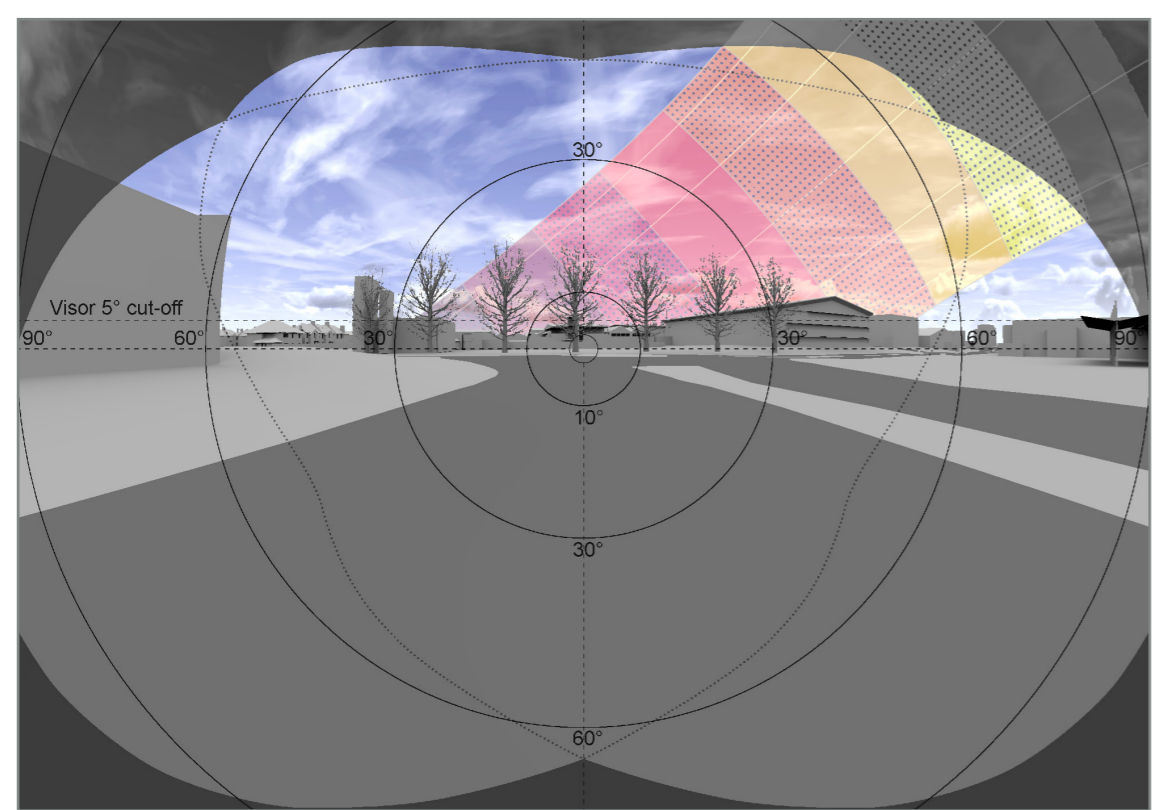
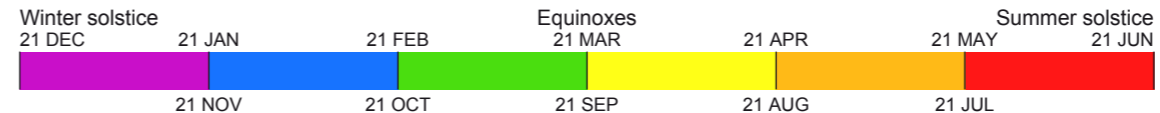

Fig. 13: Solar Glare - HOURS - 180 degrees view

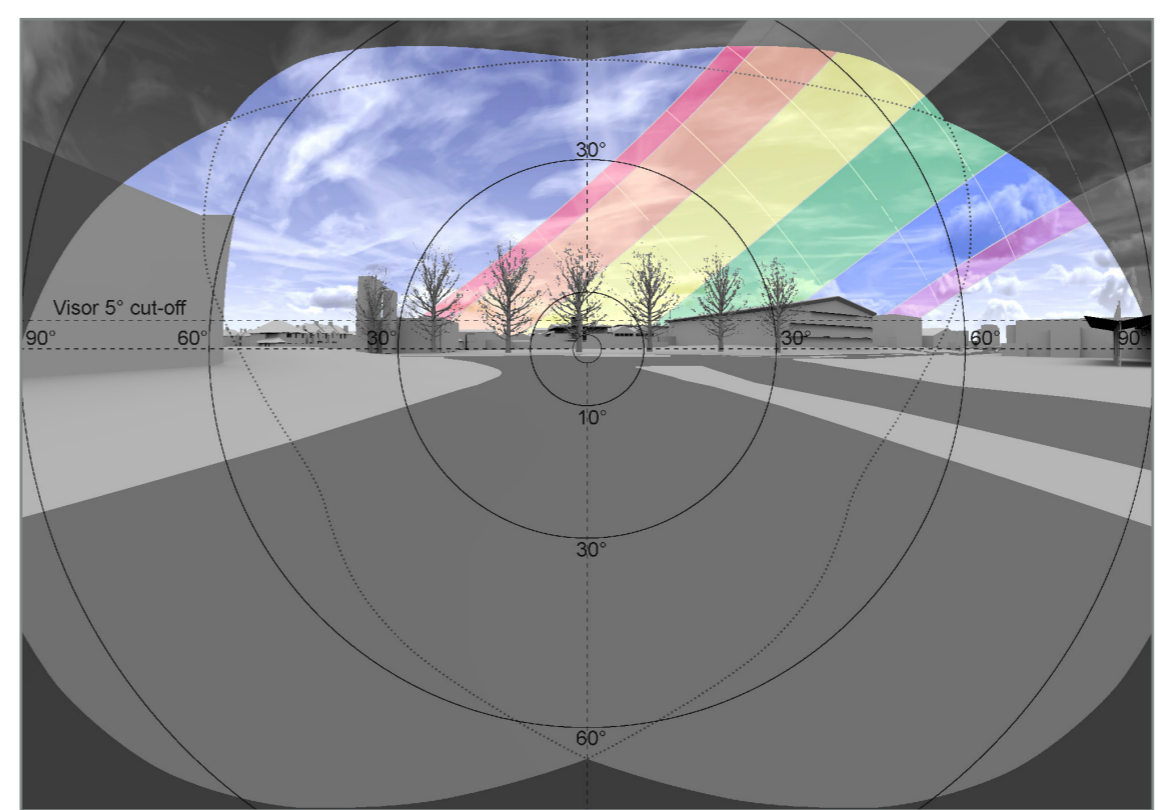

Fig. 14: Solar Glare - MONTHS - 180 degrees view

Project	Charlton Riverside Greenwich		
Reference	1864_R35_SG01		
Drawn	VL	Checked	JB
Date	29/11/2018	Rel no.	01
Drawing no.	1864_R35_SG01-4		

Title
 Reflected Solar Glare
 Frequency of Solar Reflections
 Proposed Scenario
 Bare trees
 Viewpoint V1B

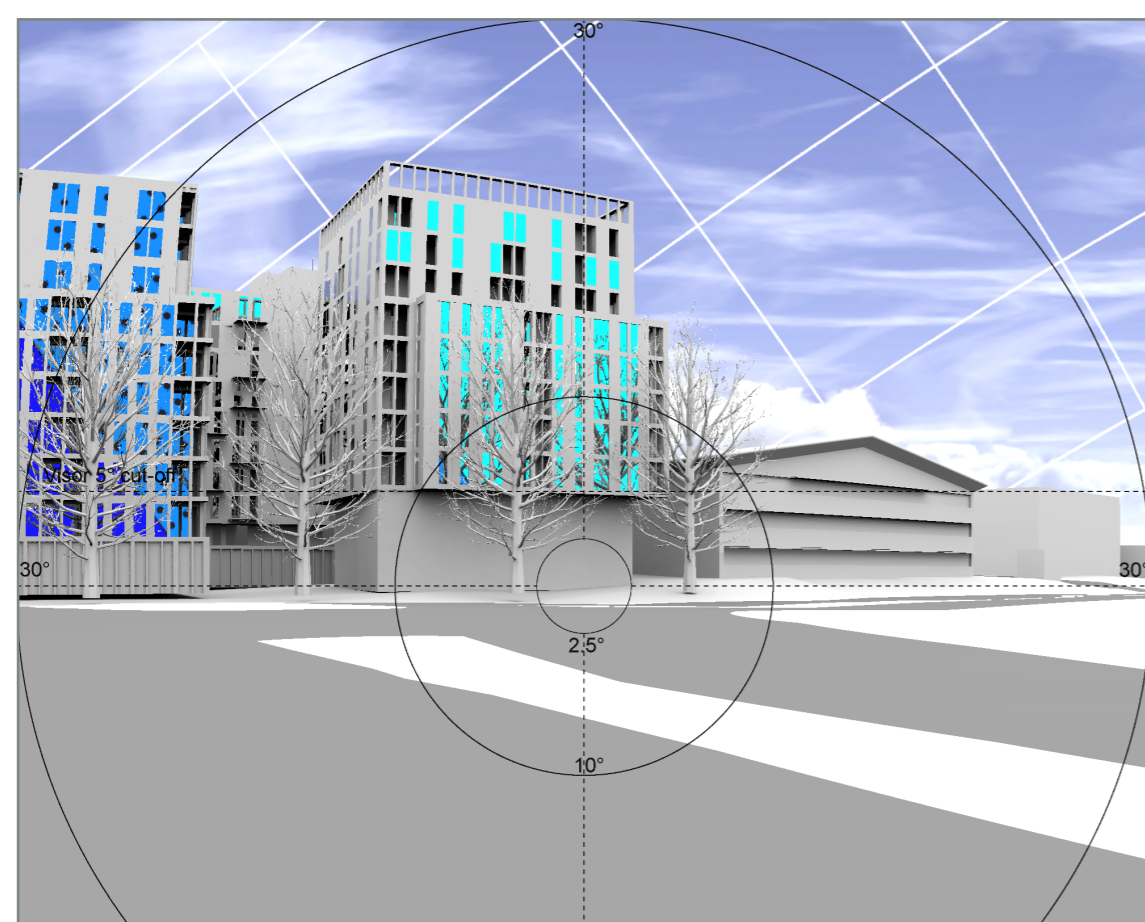

Fig. 15: Solar Glare - HOURS - Close-up

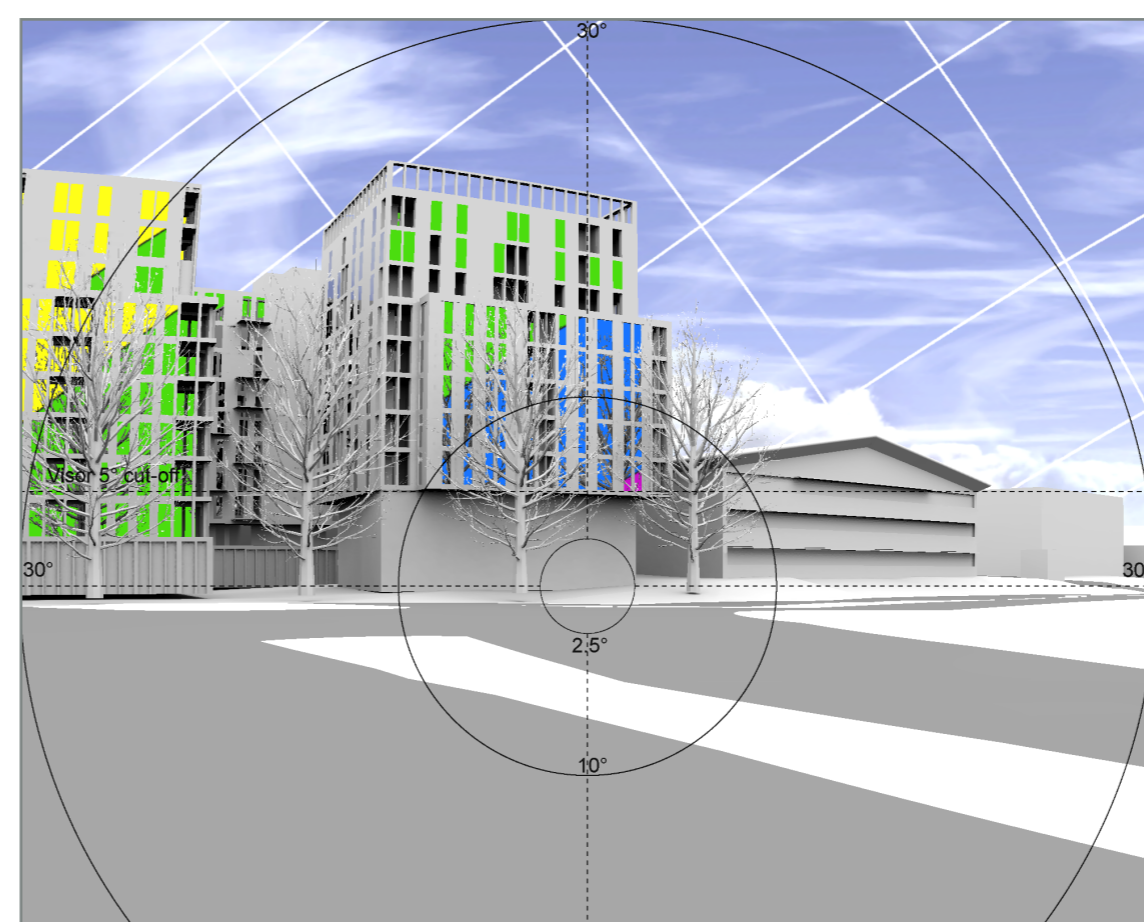
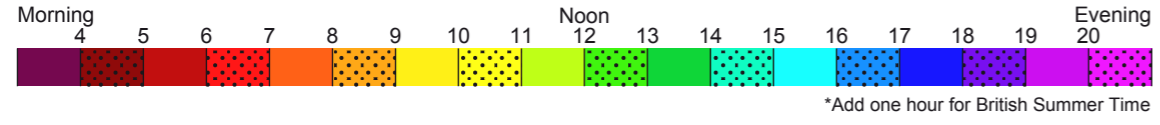

Fig. 16: Solar Glare - MONTHS - Close-up

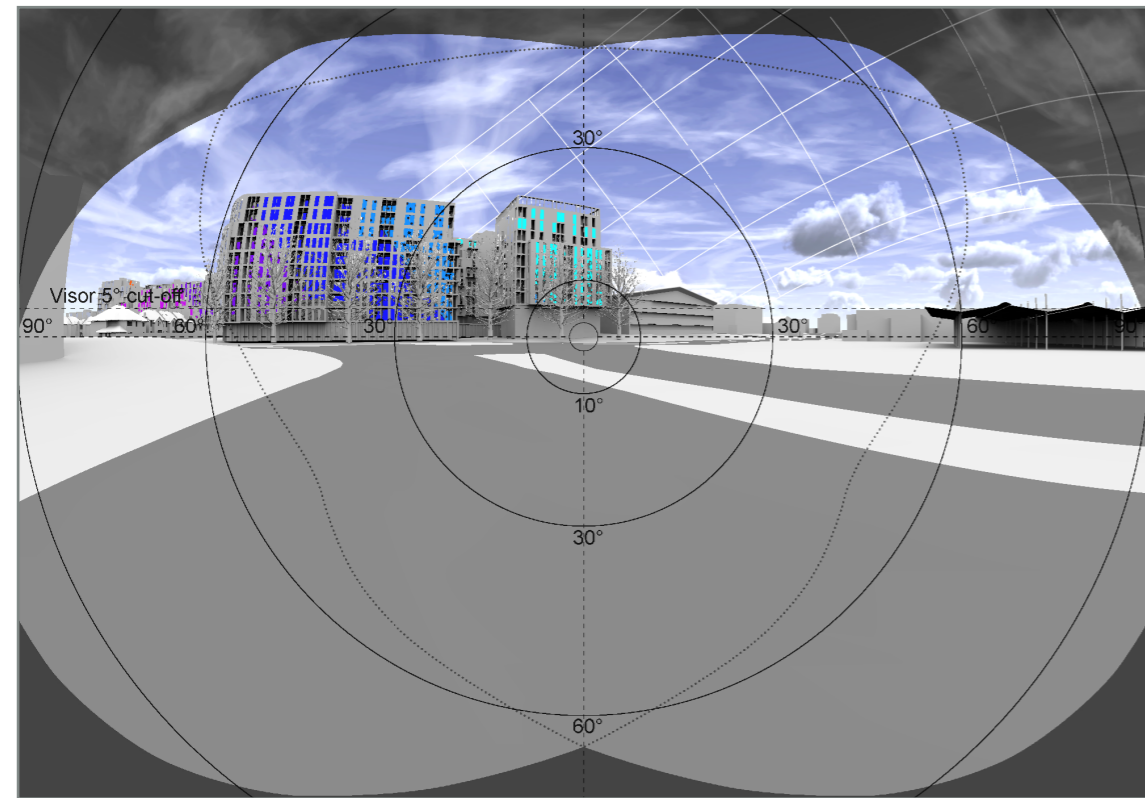
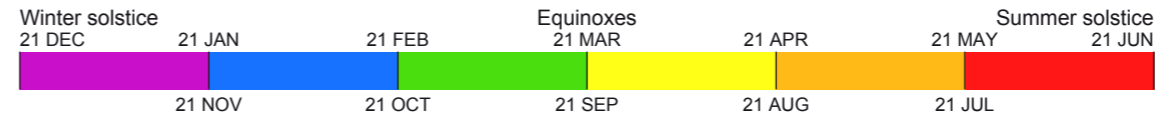

Fig. 17: Solar Glare - HOURS - 180 degrees view

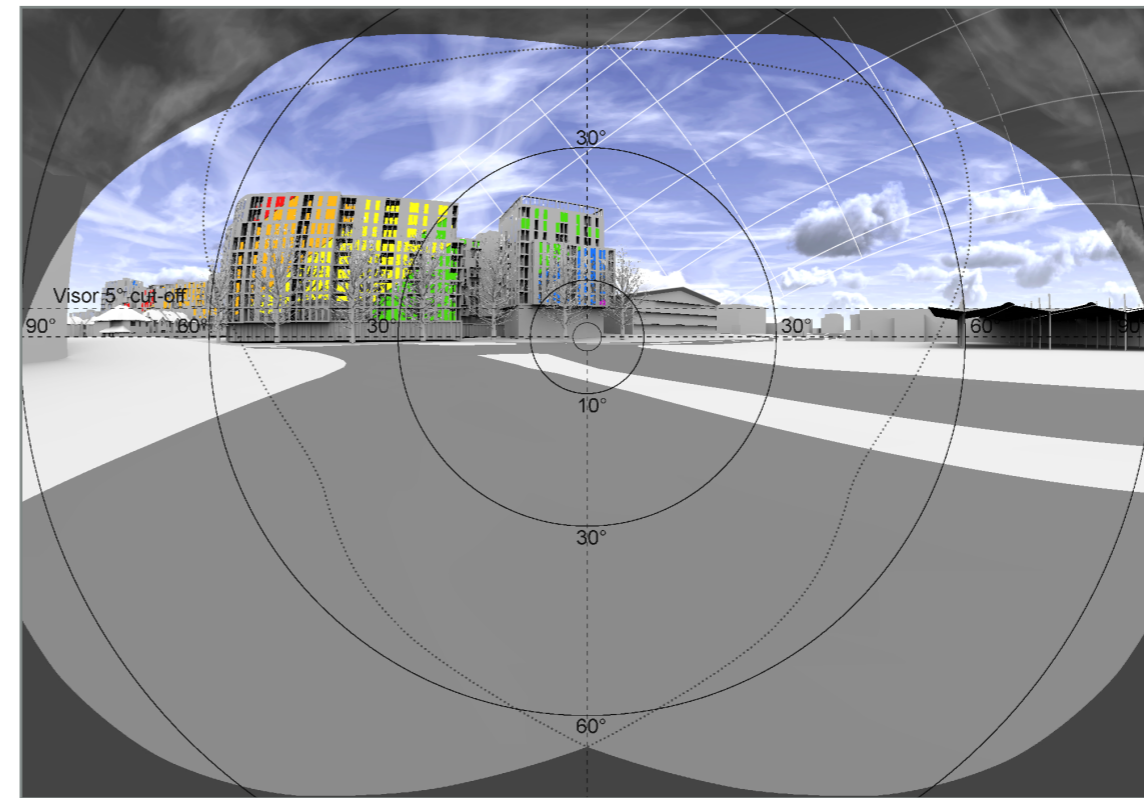

Fig. 18: Solar Glare - MONTHS - 180 degrees view

Project	Charlton Riverside Greenwich		
Reference	1864_R35_SG01		
Drawn	VL	Checked	JB
Date	29/11/2018	Rel no.	01
Drawing no.	1864_R35_SG01-5		

Title
 Reflected Solar Glare
 Frequency of Solar Reflections
 Proposed Scenario
 Trees in leaf
 Viewpoint V1B

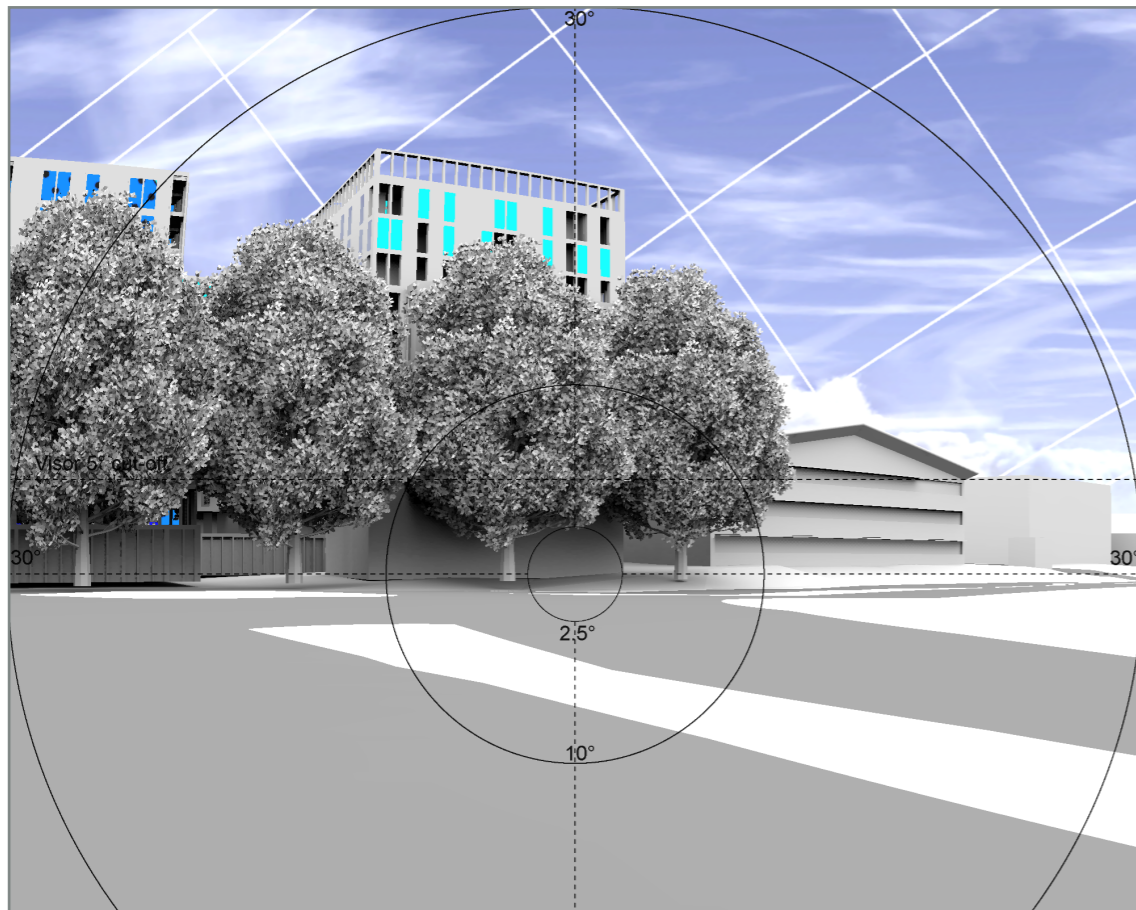

Fig. 19: Solar Glare - HOURS - Close-up

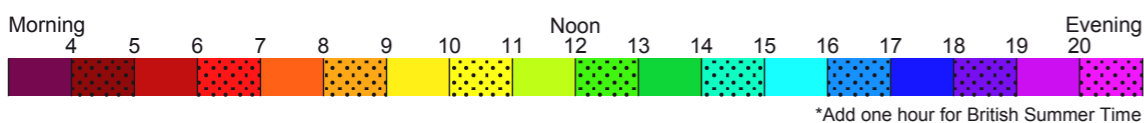

Fig. 20: Solar Glare - MONTHS - Close-up

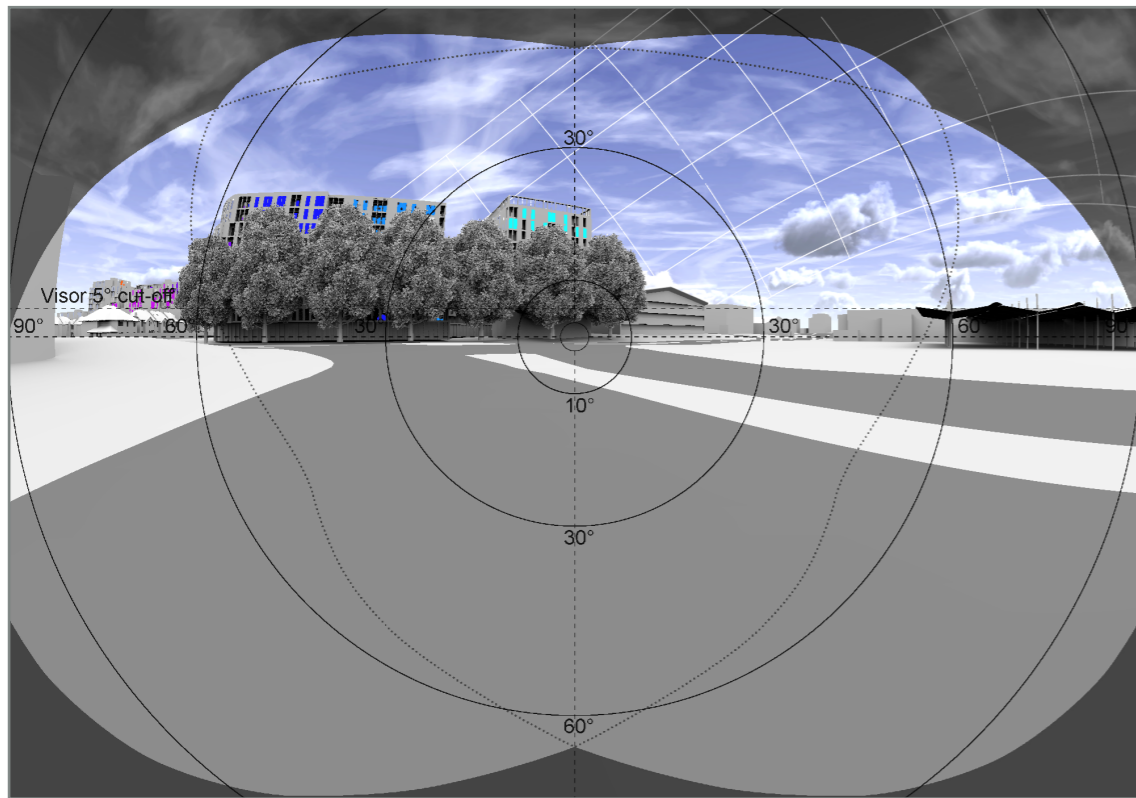
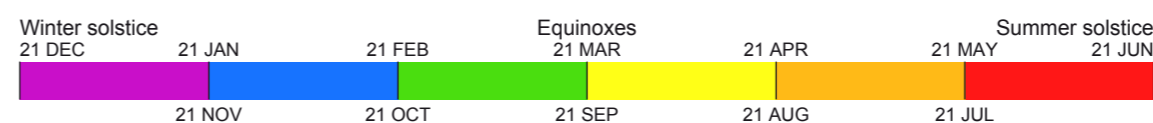

Fig. 21: Solar Glare - HOURS - 180 degrees view

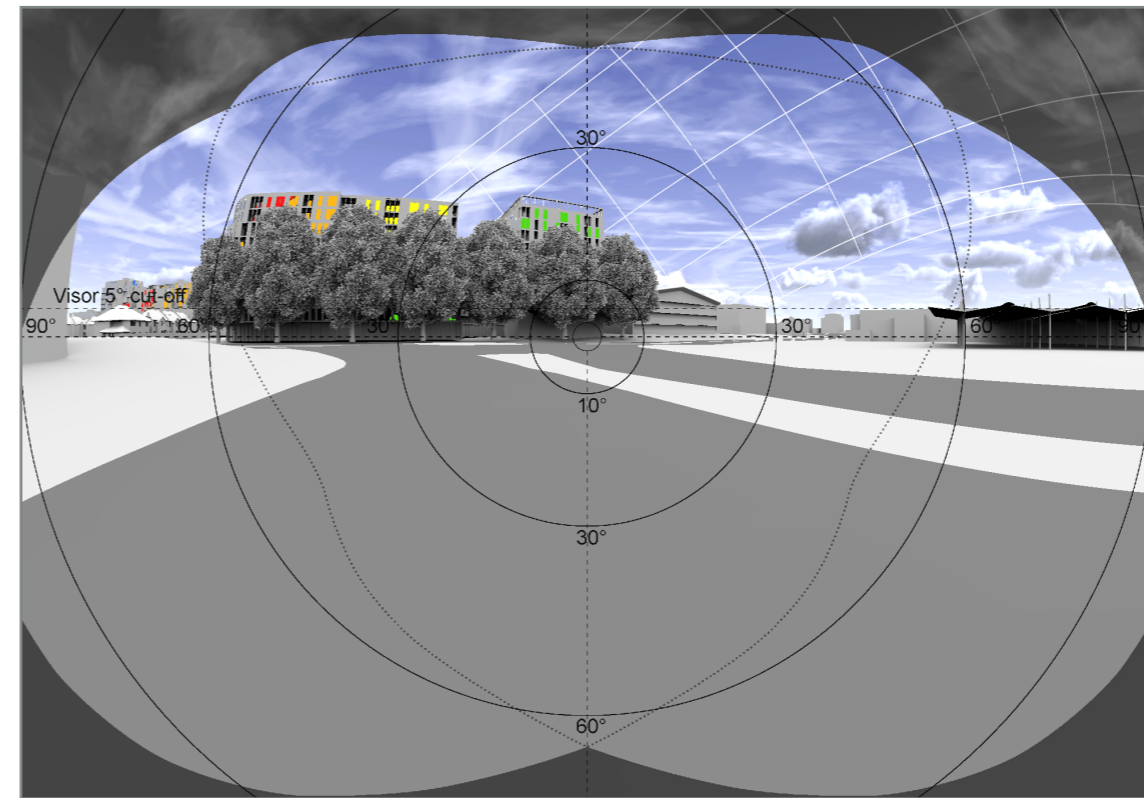

Fig. 22: Solar Glare - MONTHS - 180 degrees view

Project	Charlton Riverside Greenwich		
Reference	1864_R35_SG01		
Drawn	VL	Checked	JB
Date	29/11/2018	Rel no.	01
Drawing no.	1864_R35_SG01-6		

Title
 Reflected Solar Glare
 Frequency of Solar Reflections
 Existing Scenario
 Bare trees
 Viewpoint V1B

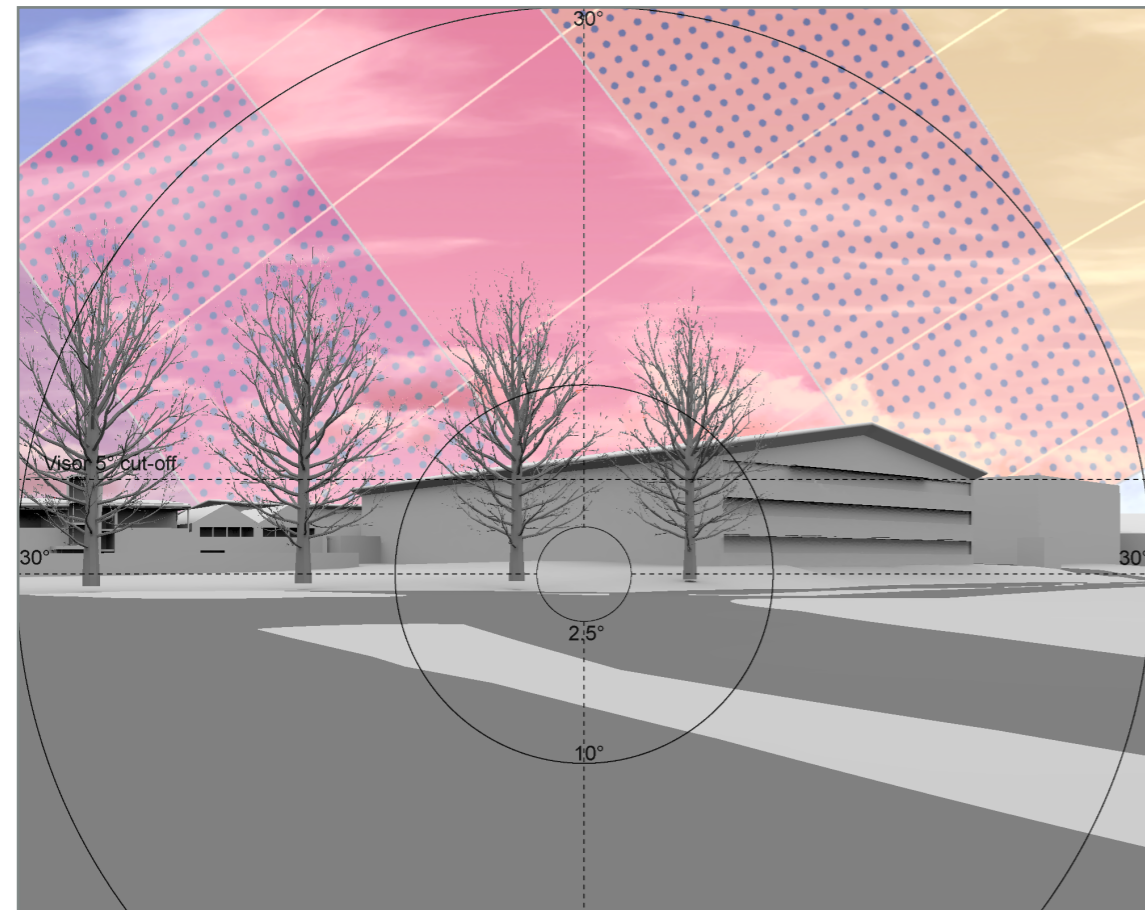

Fig. 23: Solar Glare - HOURS - Close-up

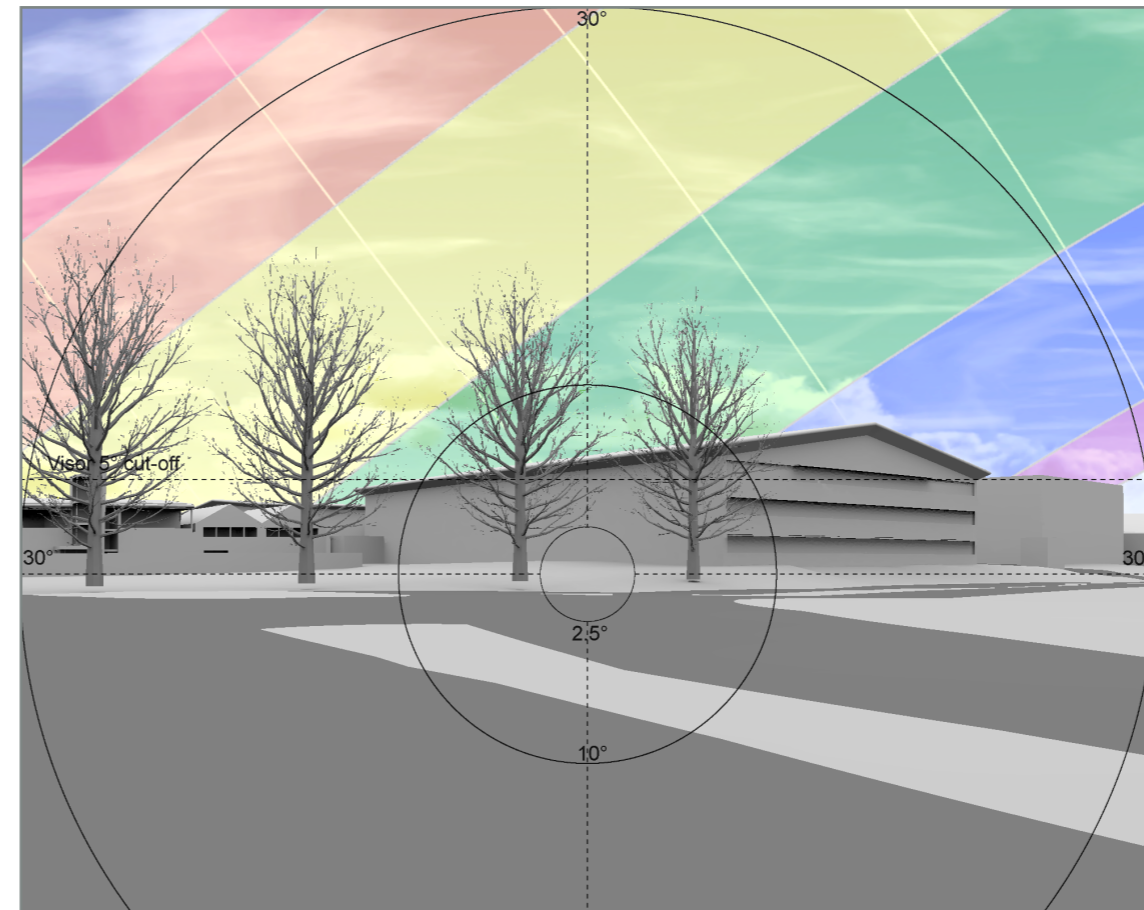
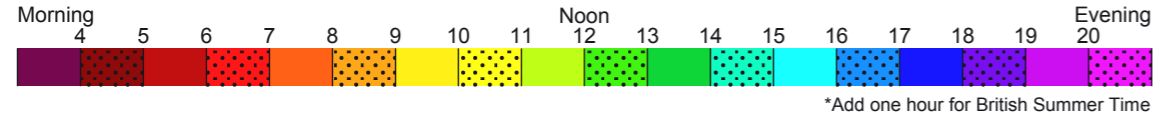

Fig. 24: Solar Glare - MONTHS - Close-up

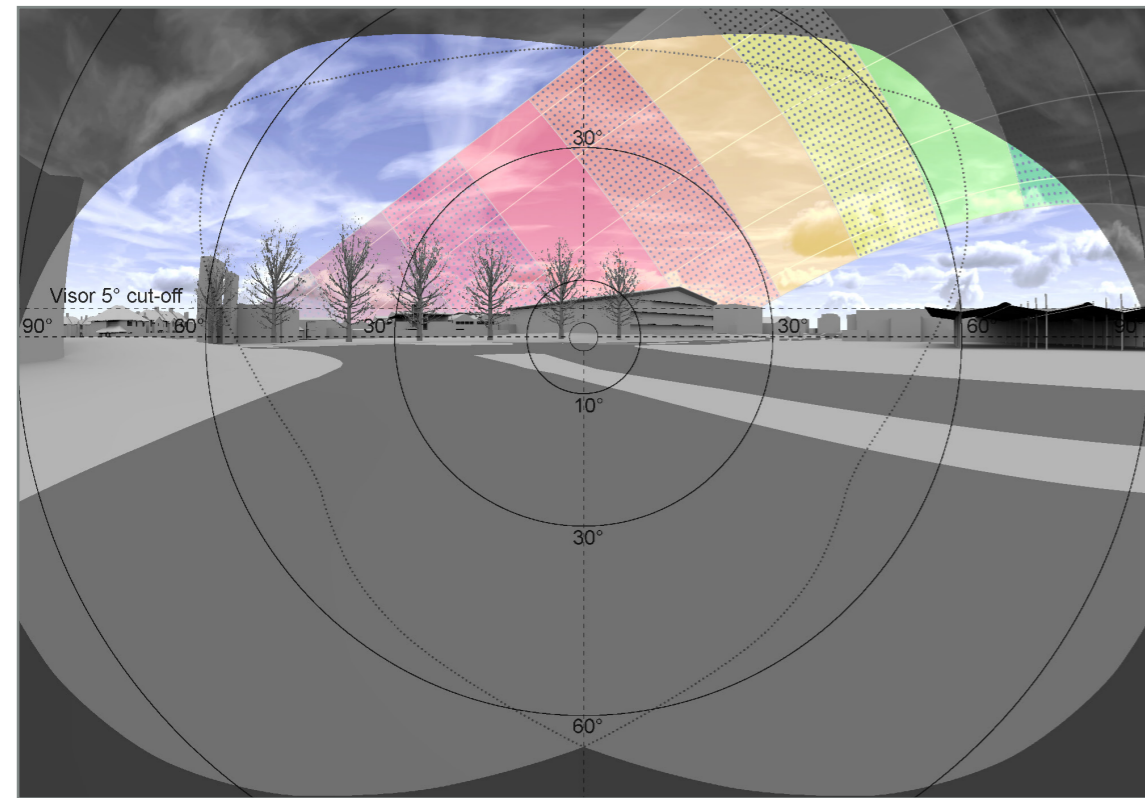
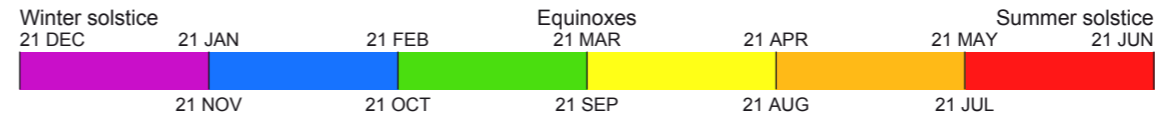

Fig. 25: Solar Glare - HOURS - 180 degrees view

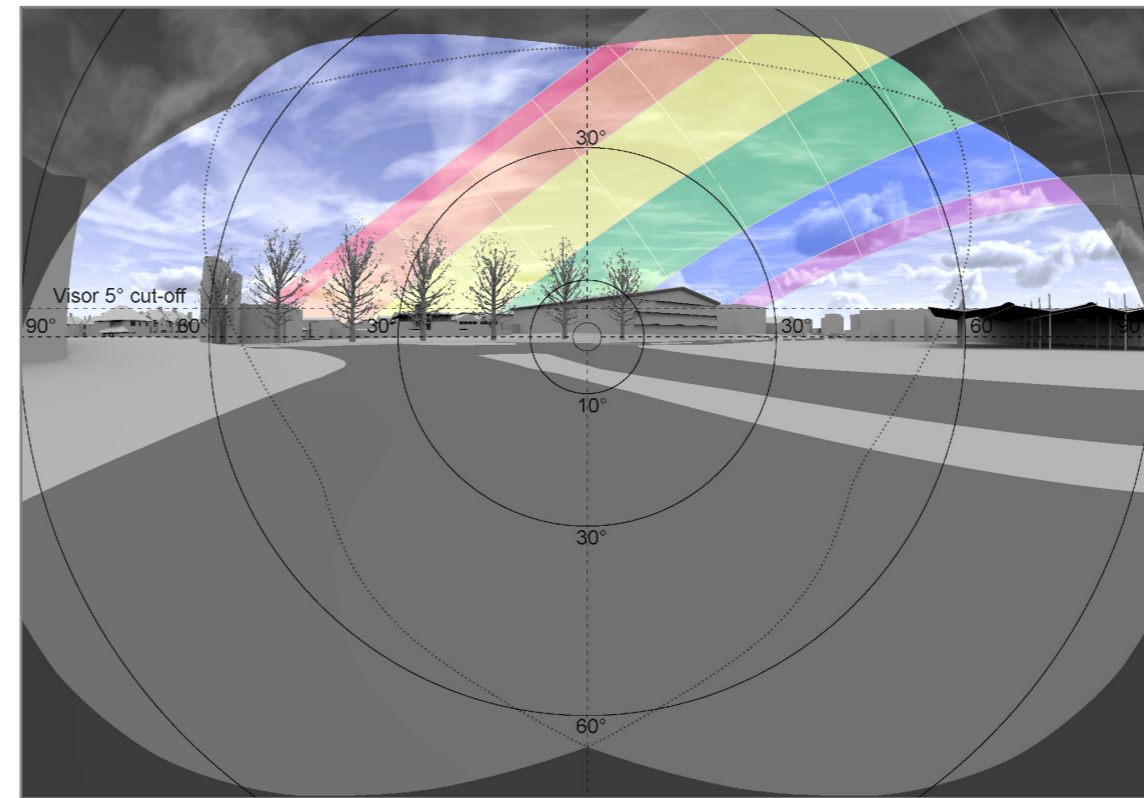

Fig. 26: Solar Glare - MONTHS - 180 degrees view

Project	Charlton Riverside Greenwich		
Reference	1864_R35_SG01		
Drawn	VL	Checked	JB
Date	29/11/2018	Rel no.	01
Drawing no.	1864_R35_SG01-7		

Title
 Reflected Solar Glare
 Frequency of Solar Reflections
 Proposed Scenario
 Bare trees
 Viewpoint V2

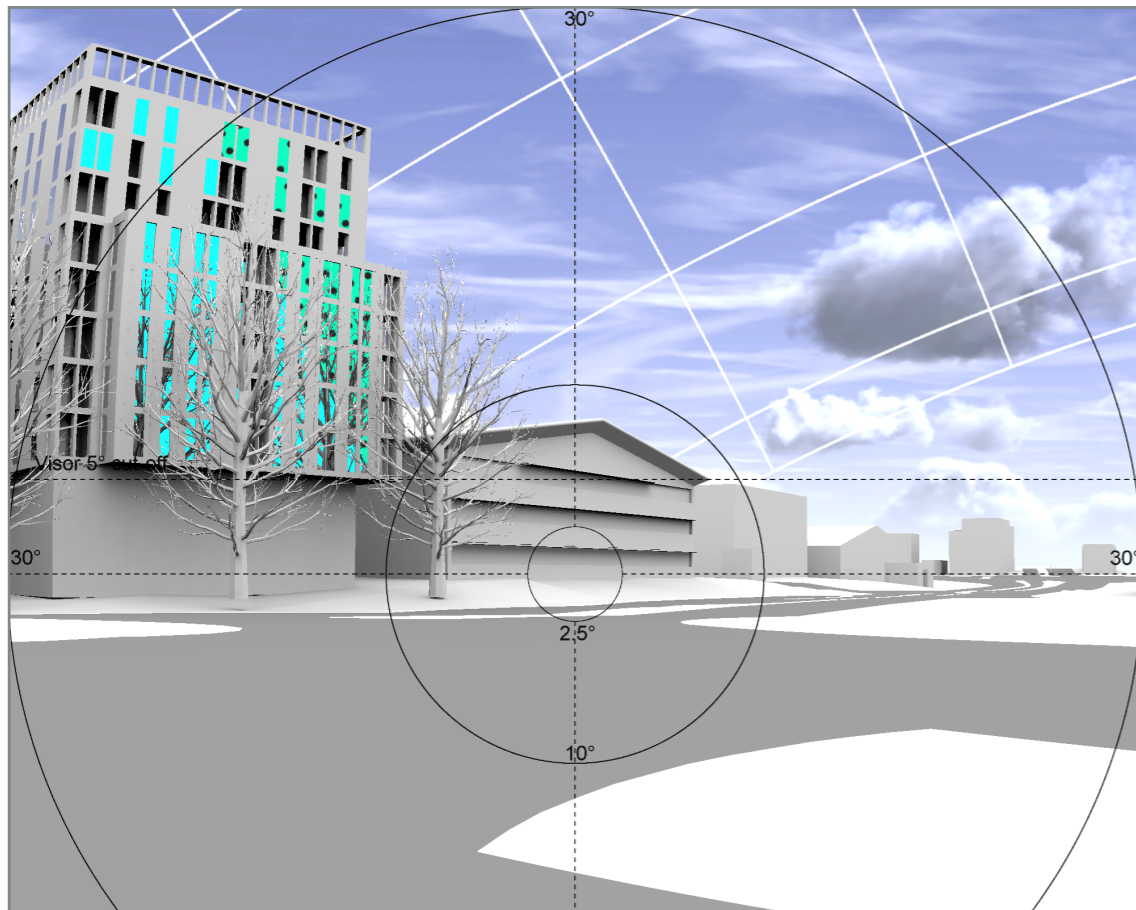

Fig. 27: Solar Glare - HOURS - Close-up

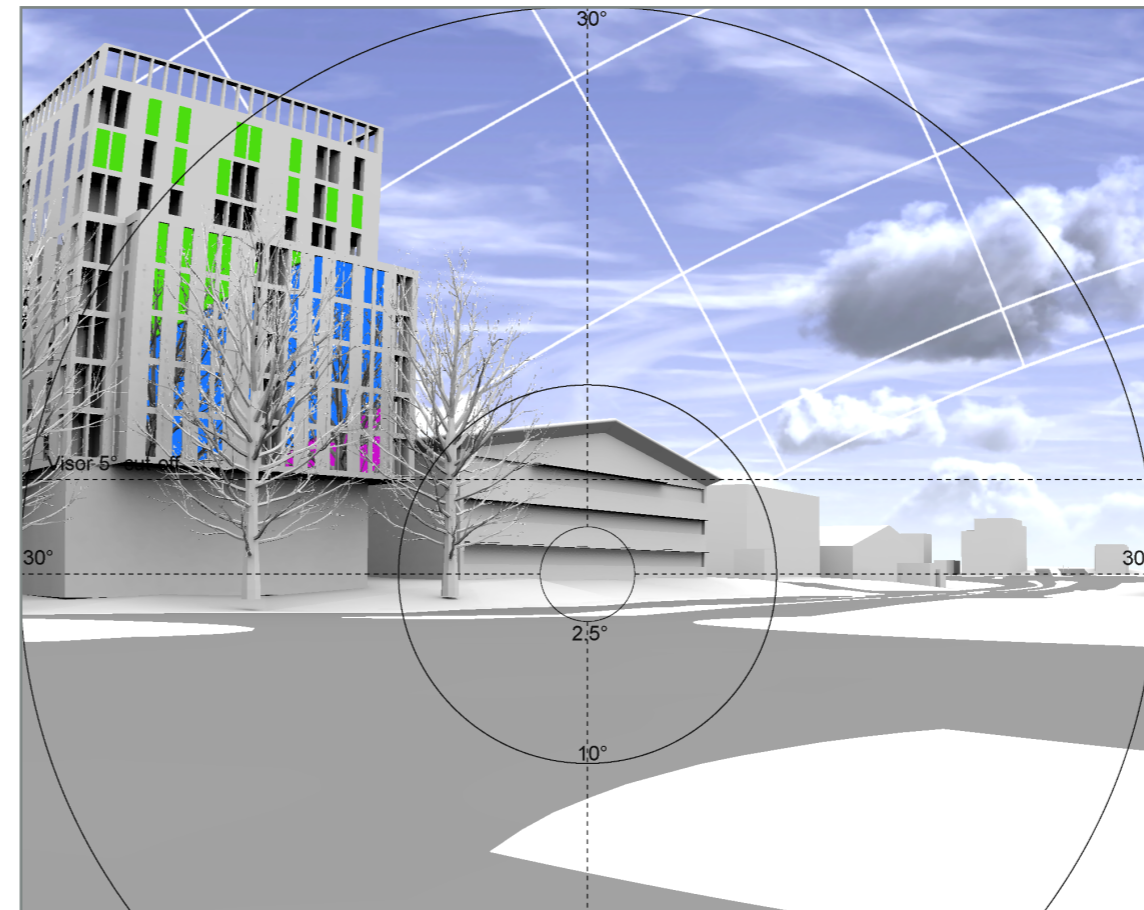
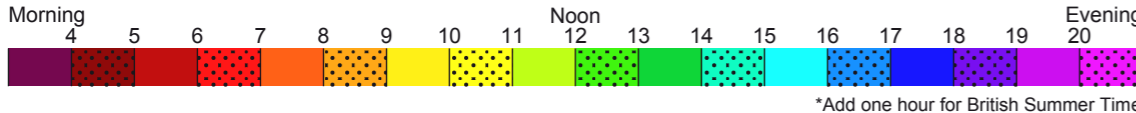

Fig. 28: Solar Glare - MONTHS - Close-up

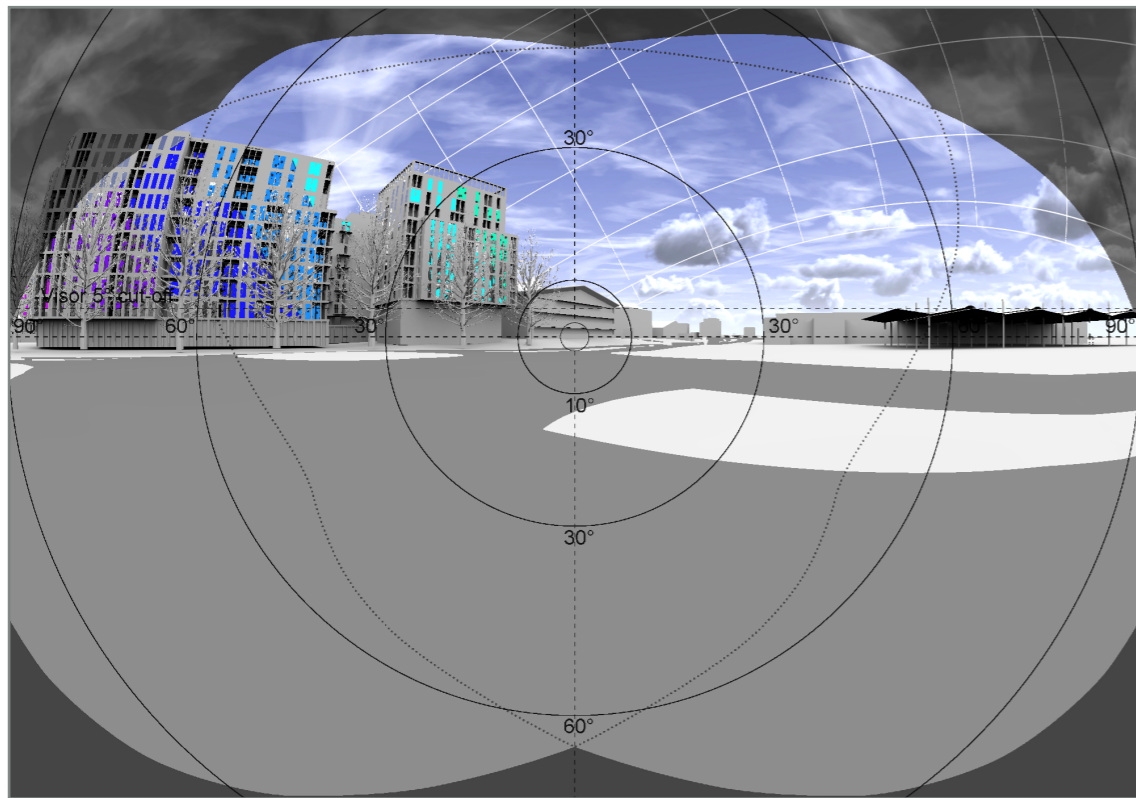
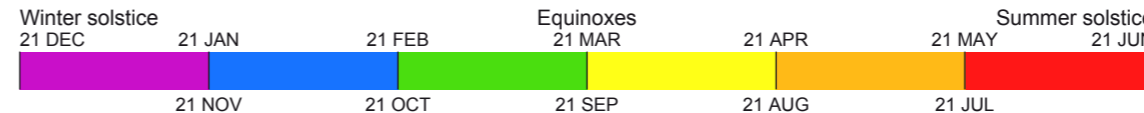

Fig. 29: Solar Glare - HOURS - 180 degrees view

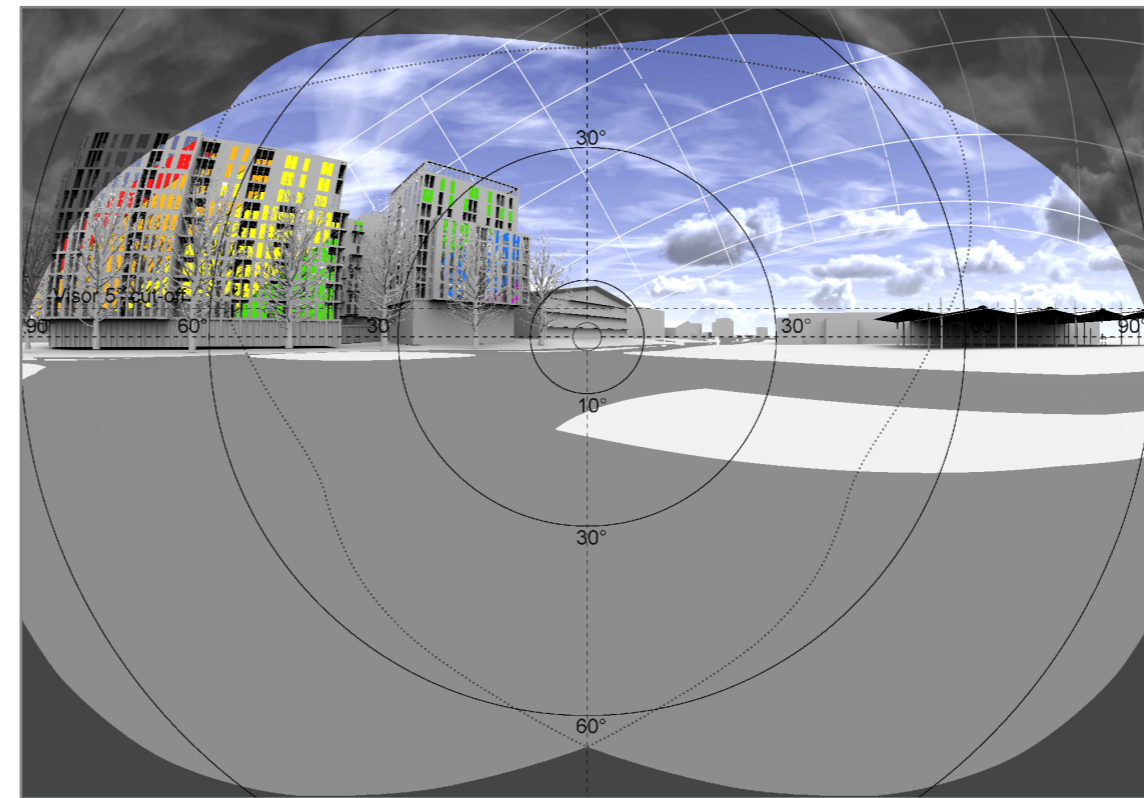

Fig. 30: Solar Glare - MONTHS - 180 degrees view

Project	Charlton Riverside Greenwich		
Reference	1864_R35_SG01		
Drawn	VL	Checked	JB
Date	29/11/2018	Rel no.	01
Drawing no.	1864_R35_SG01-8		

Title
 Reflected Solar Glare
 Frequency of Solar Reflections
 Proposed Scenario
 Trees in leaf
 Viewpoint V2

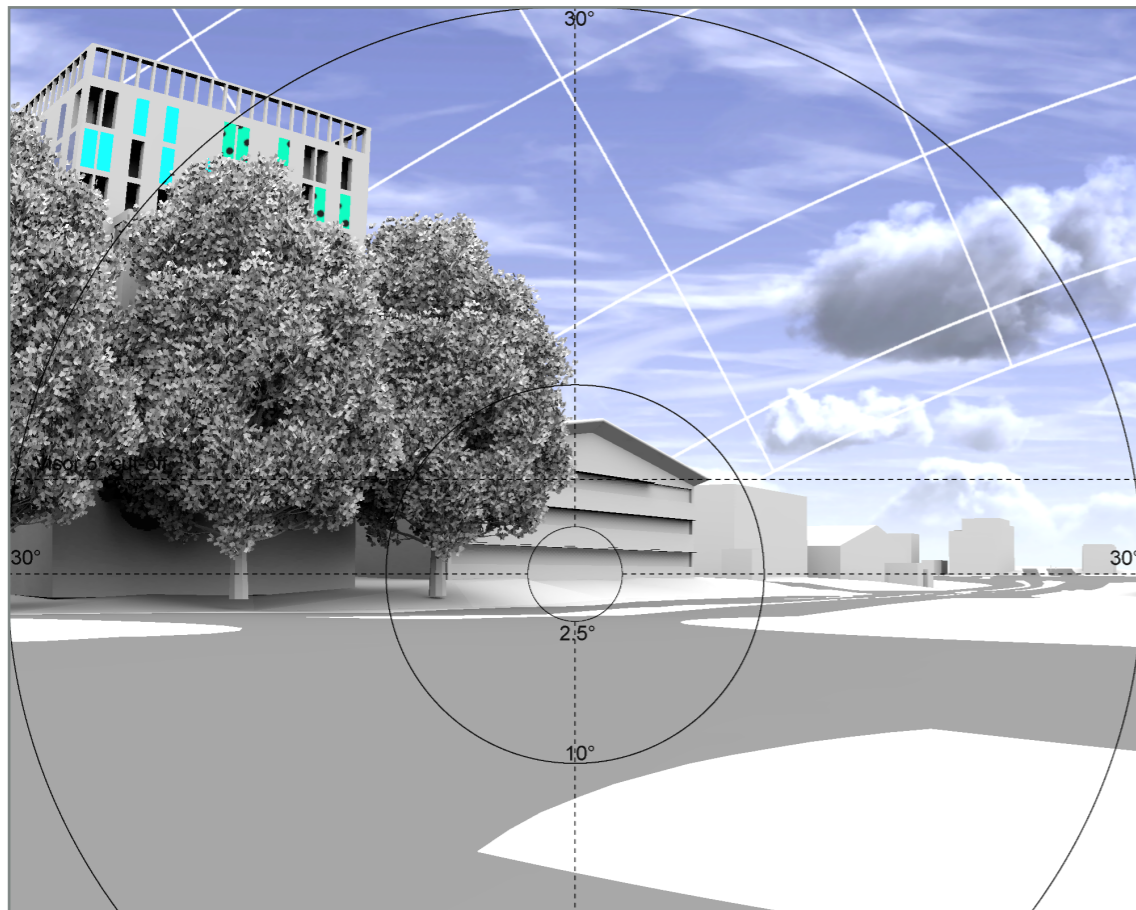

Fig. 31: Solar Glare - HOURS - Close-up

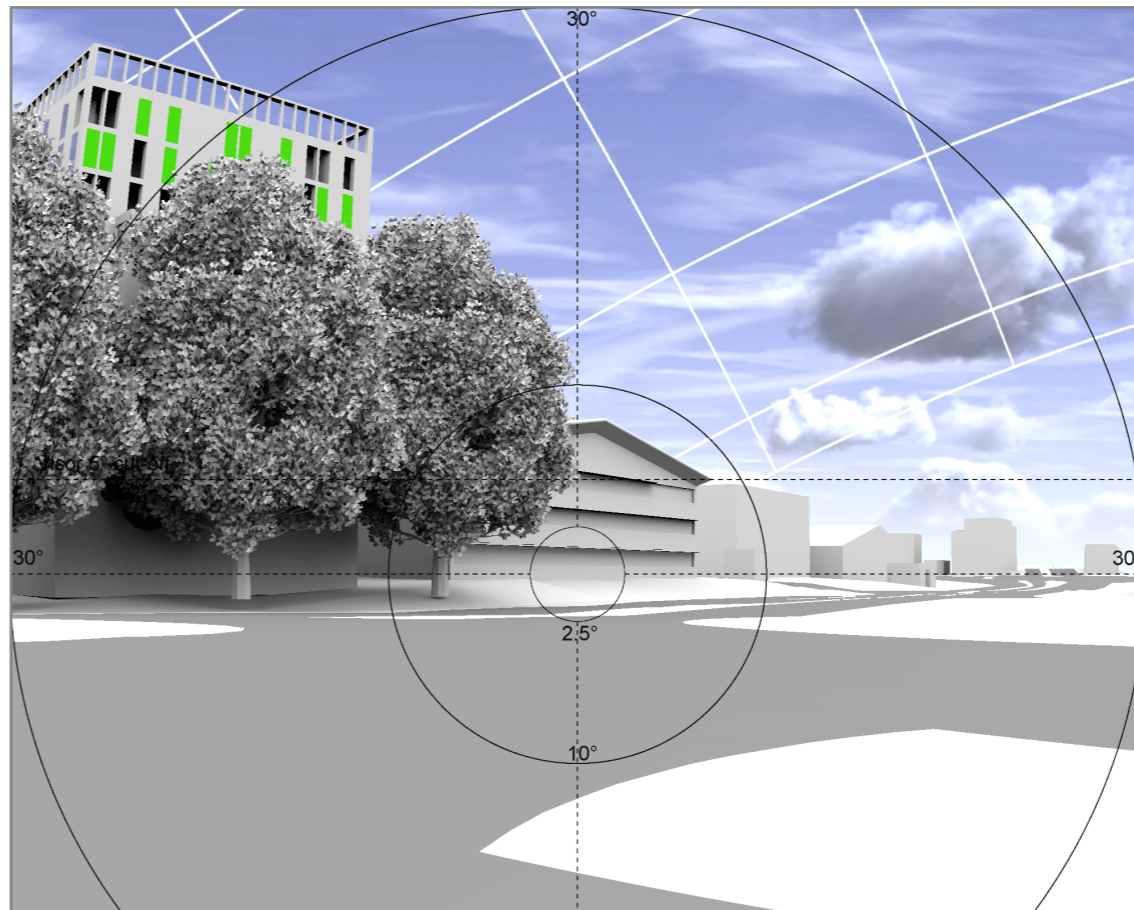
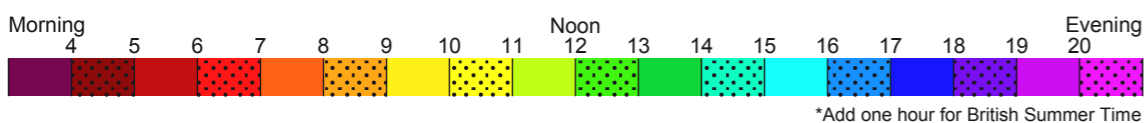

Fig. 32: Solar Glare - MONTHS - Close-up

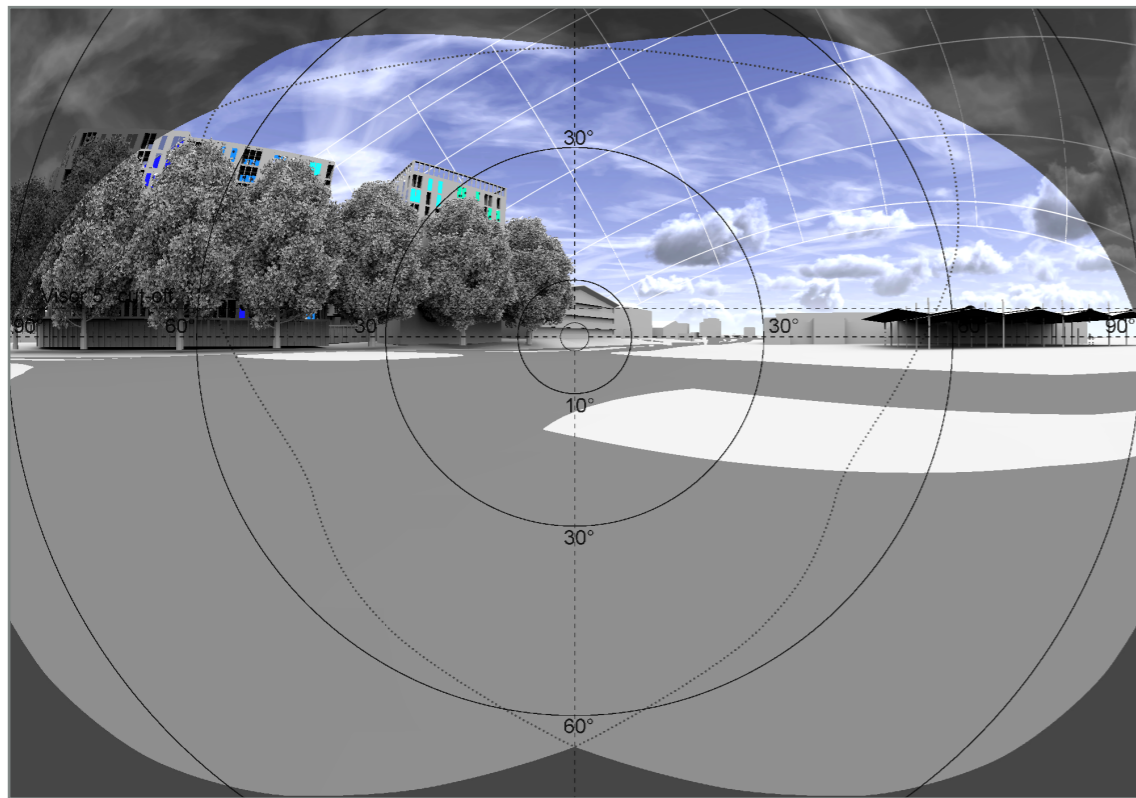
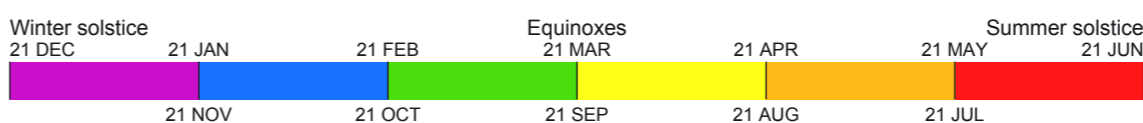

Fig. 33: Solar Glare - HOURS - 180 degrees view

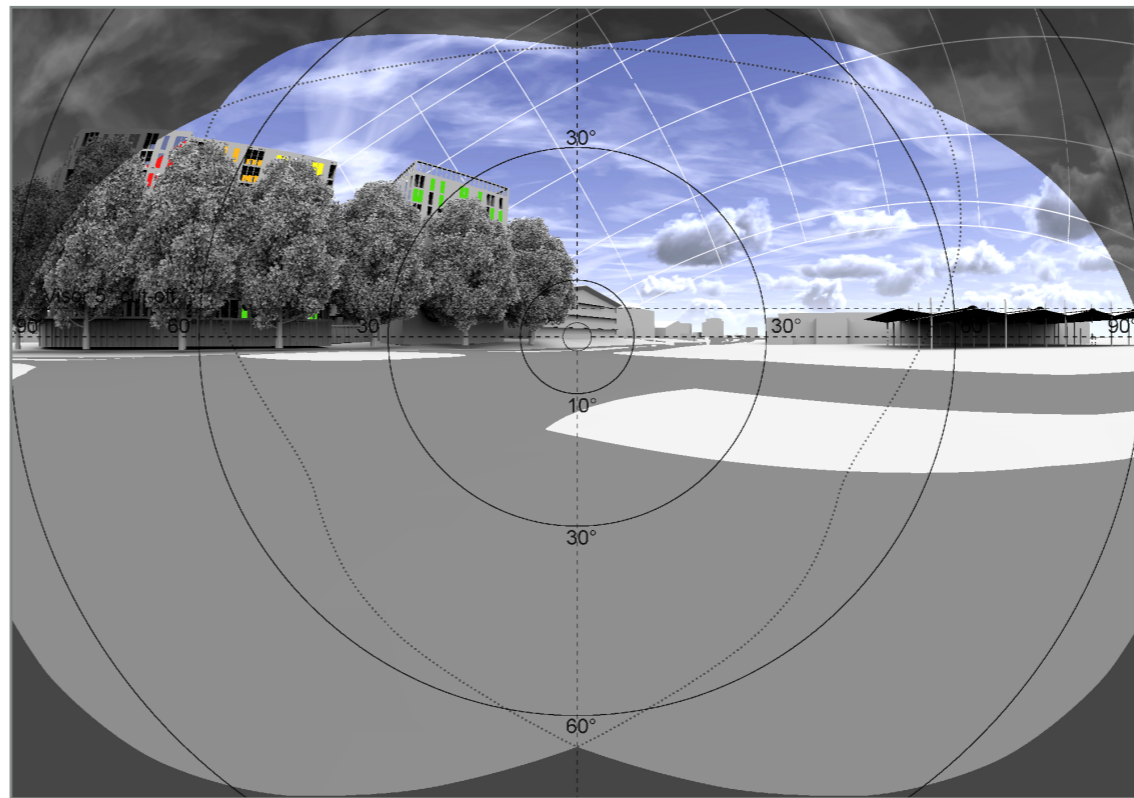

Fig. 34: Solar Glare - MONTHS - 180 degrees view

Project	Charlton Riverside Greenwich		
Reference	1864_R35_SG01		
Drawn	VL	Checked	JB
Date	29/11/2018	Rel no.	01
Drawing no.	1864_R35_SG01-9		

Title
 Reflected Solar Glare
 Frequency of Solar Reflections
 Existing Scenario
 Bare trees
 Viewpoint V2

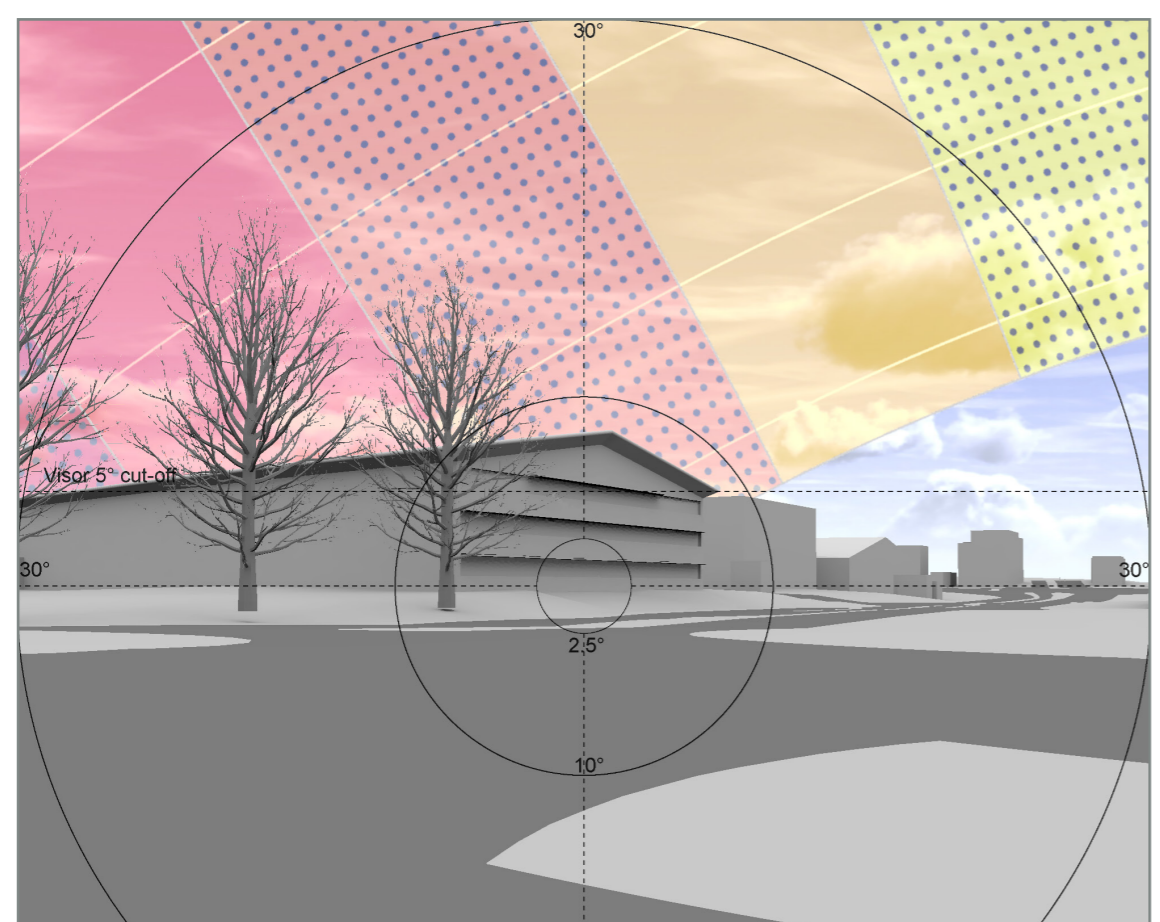

Fig. 35: Solar Glare - HOURS - Close-up

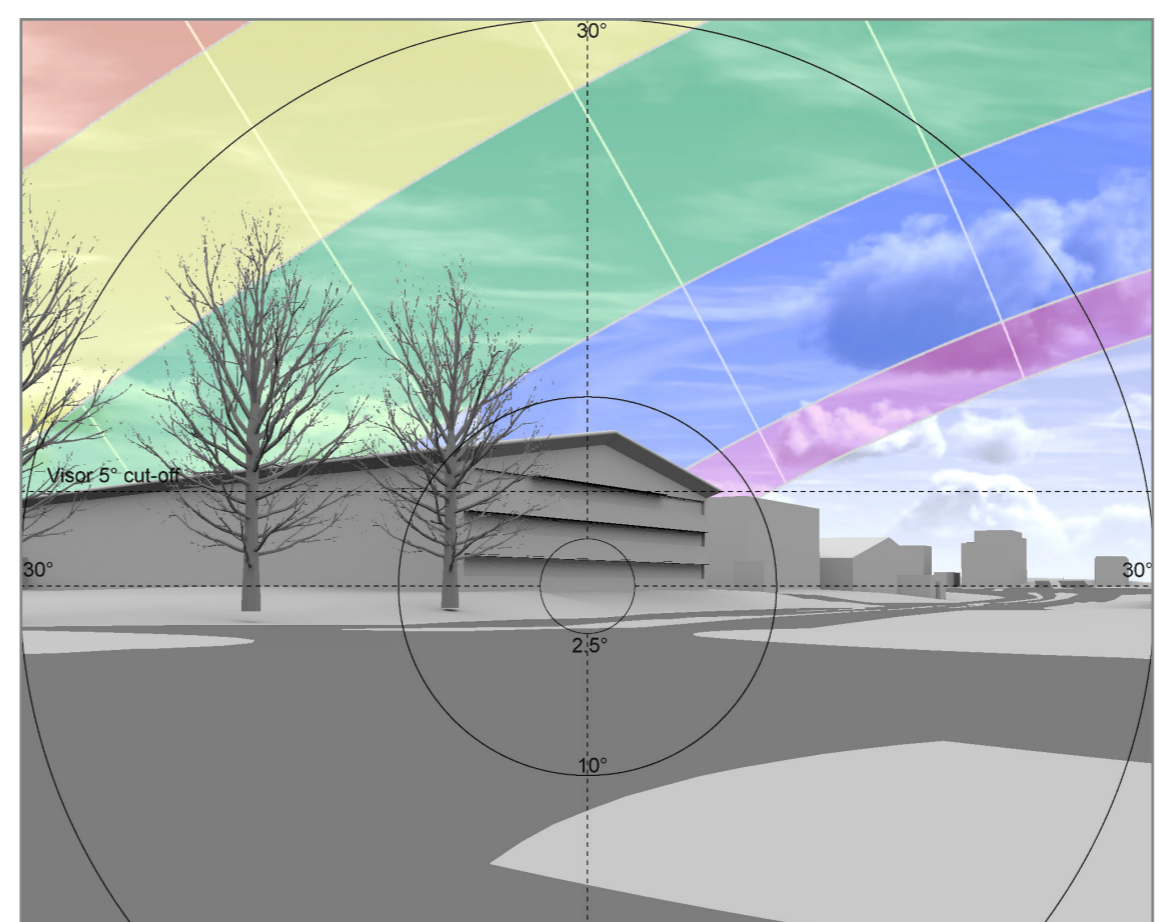
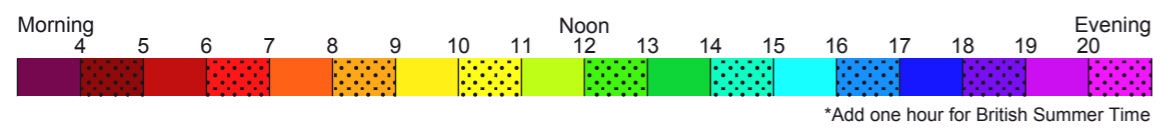

Fig. 36: Solar Glare - MONTHS - Close-up

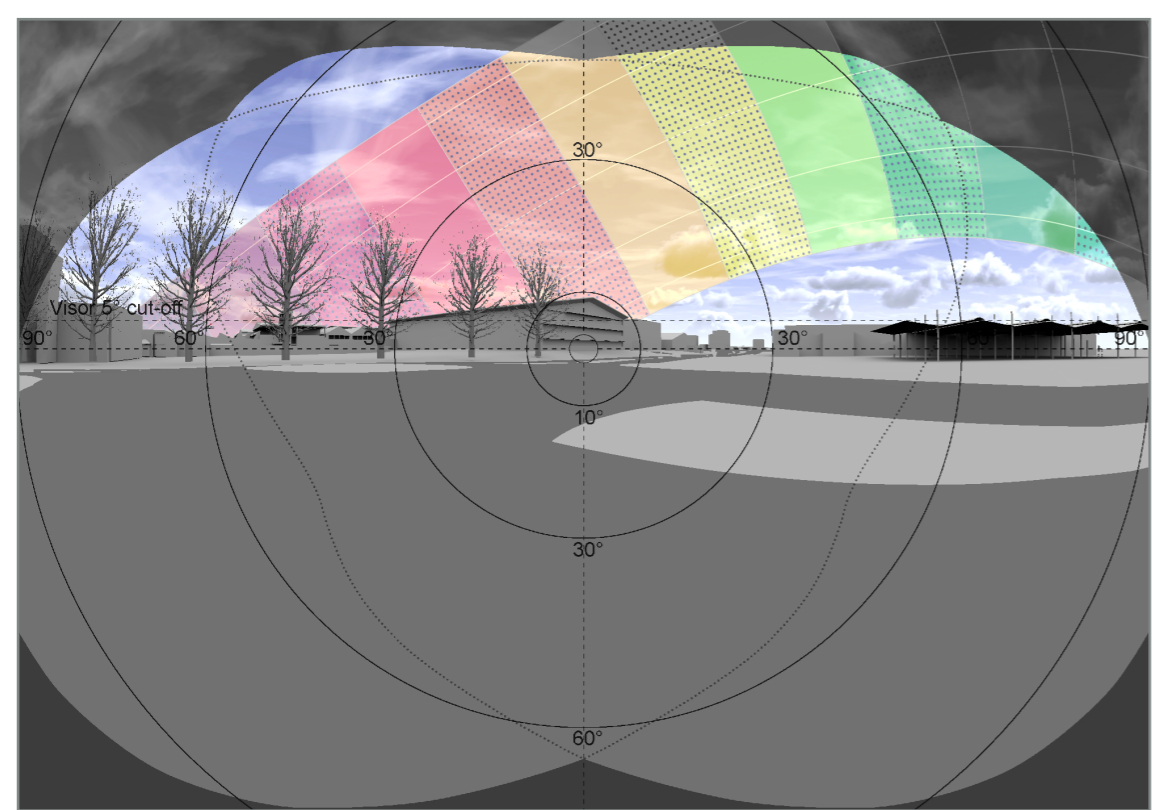
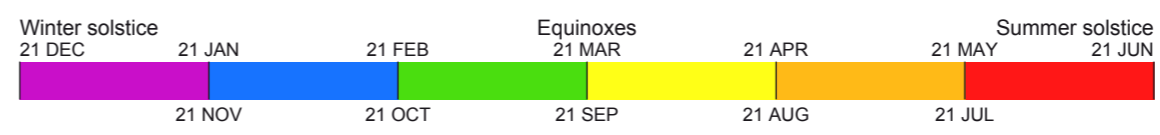

Fig. 37: Solar Glare - HOURS - 180 degrees view

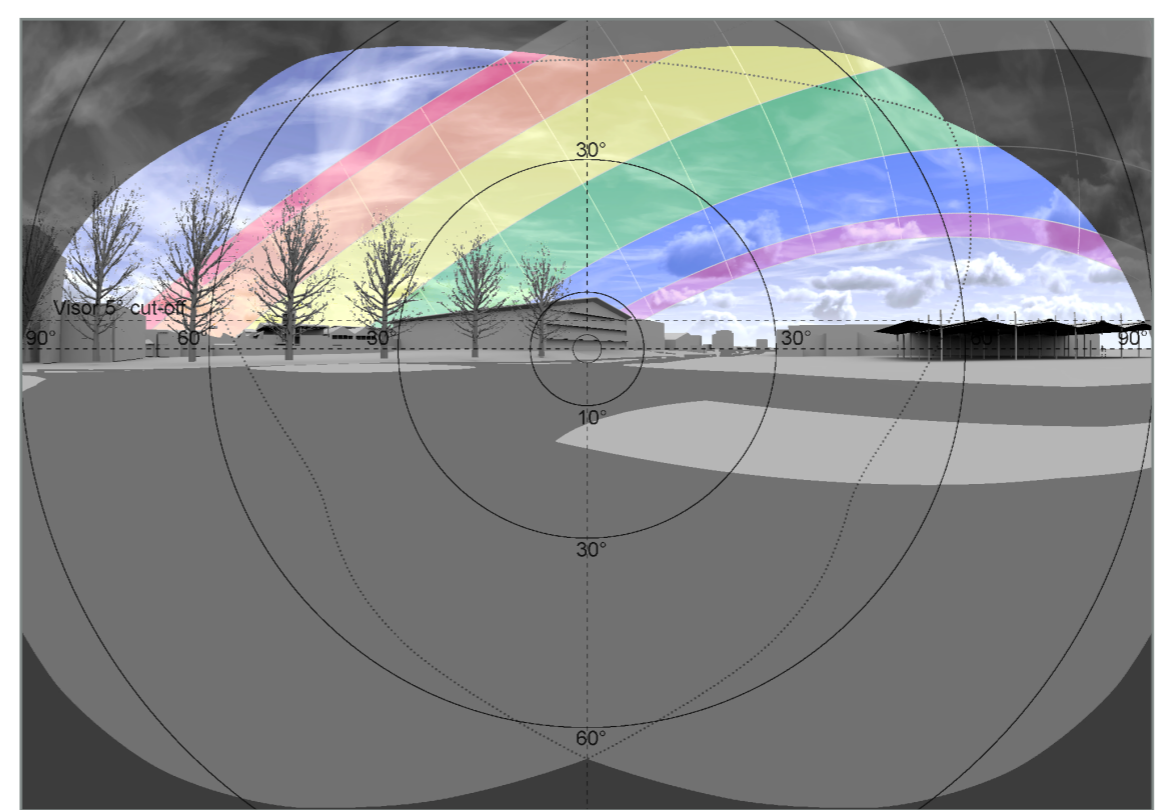

Fig. 38: Solar Glare - MONTHS - 180 degrees view

Project	Charlton Riverside Greenwich		
Reference	1864_R35_SG01		
Drawn	VL	Checked	JB
Date	29/11/2018	Rel no.	01
Drawing no.	1864_R35_SG01-10		

Title
 Reflected Solar Glare
 Frequency of Solar Reflections
 Proposed Scenario
 Bare trees
 Viewpoint V3A

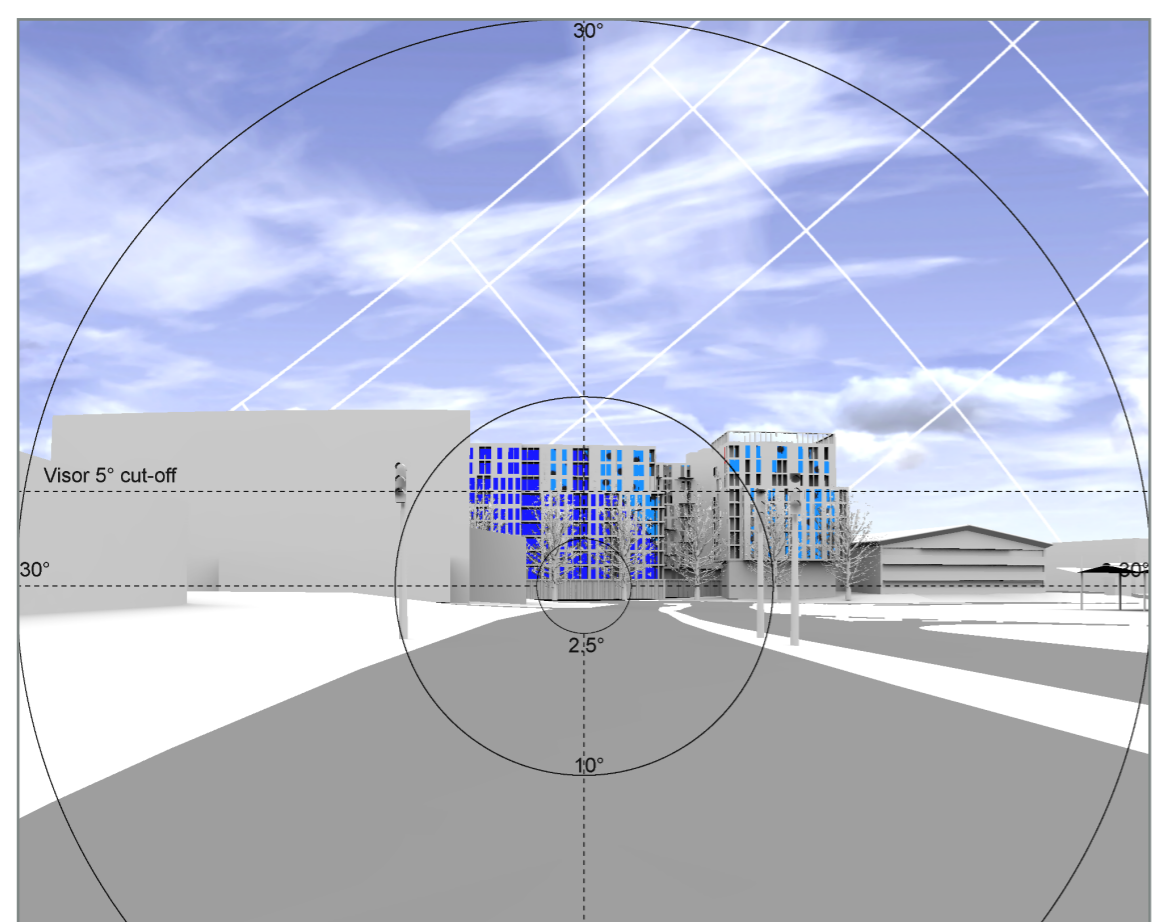

Fig. 39: Solar Glare - HOURS - Close-up

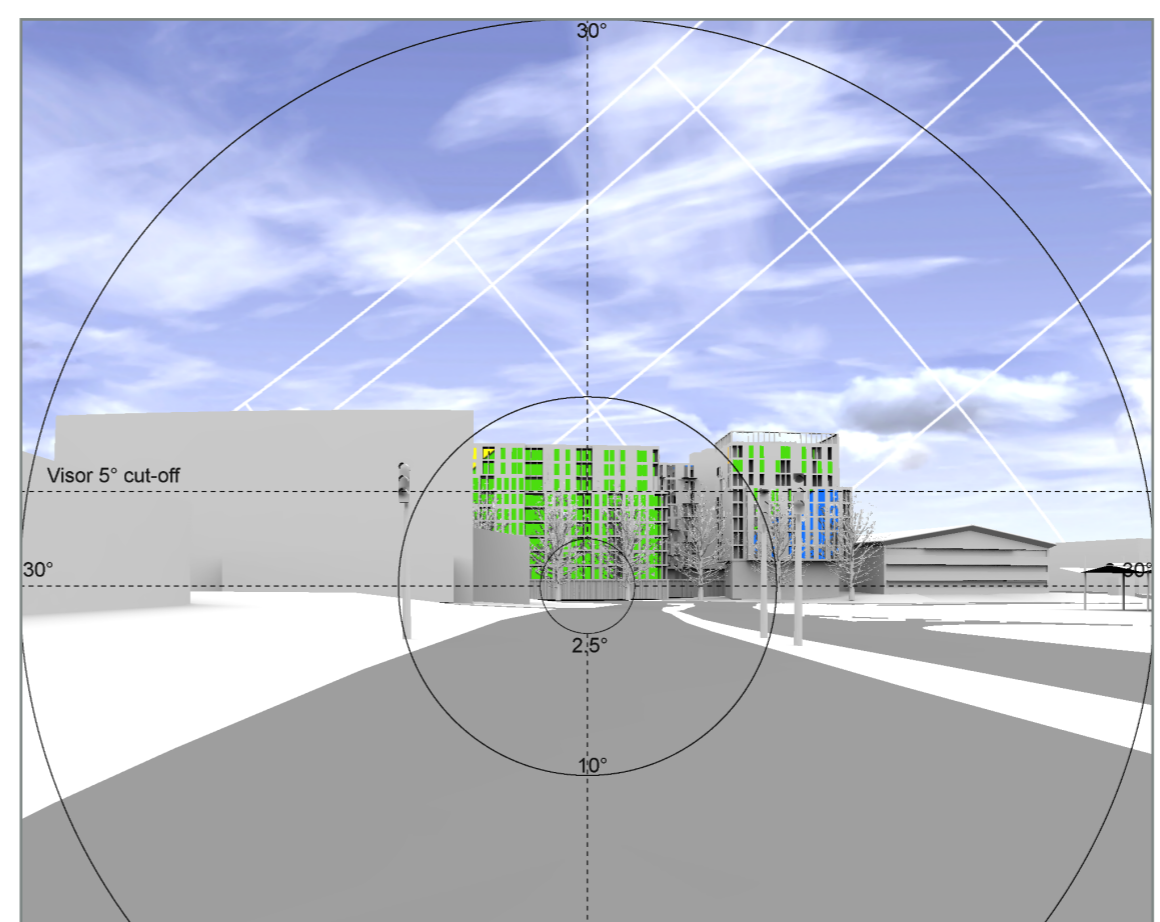
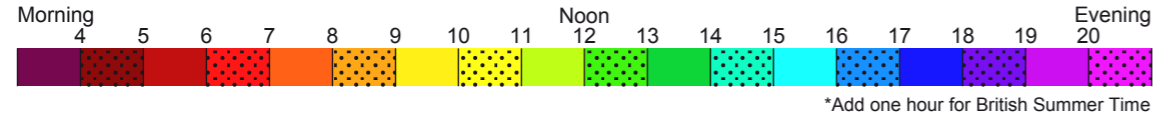

Fig. 40: Solar Glare - MONTHS - Close-up

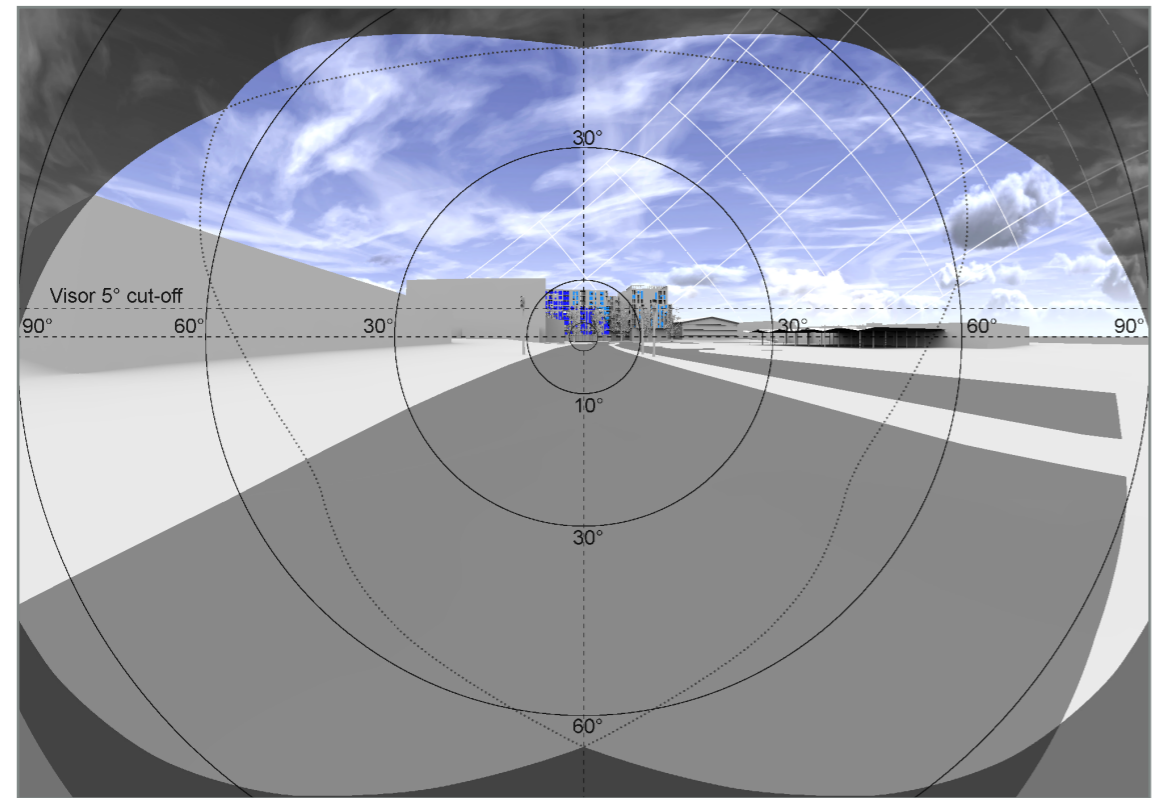
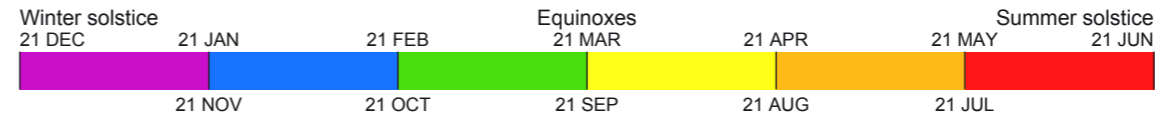

Fig. 41: Solar Glare - HOURS - 180 degrees view

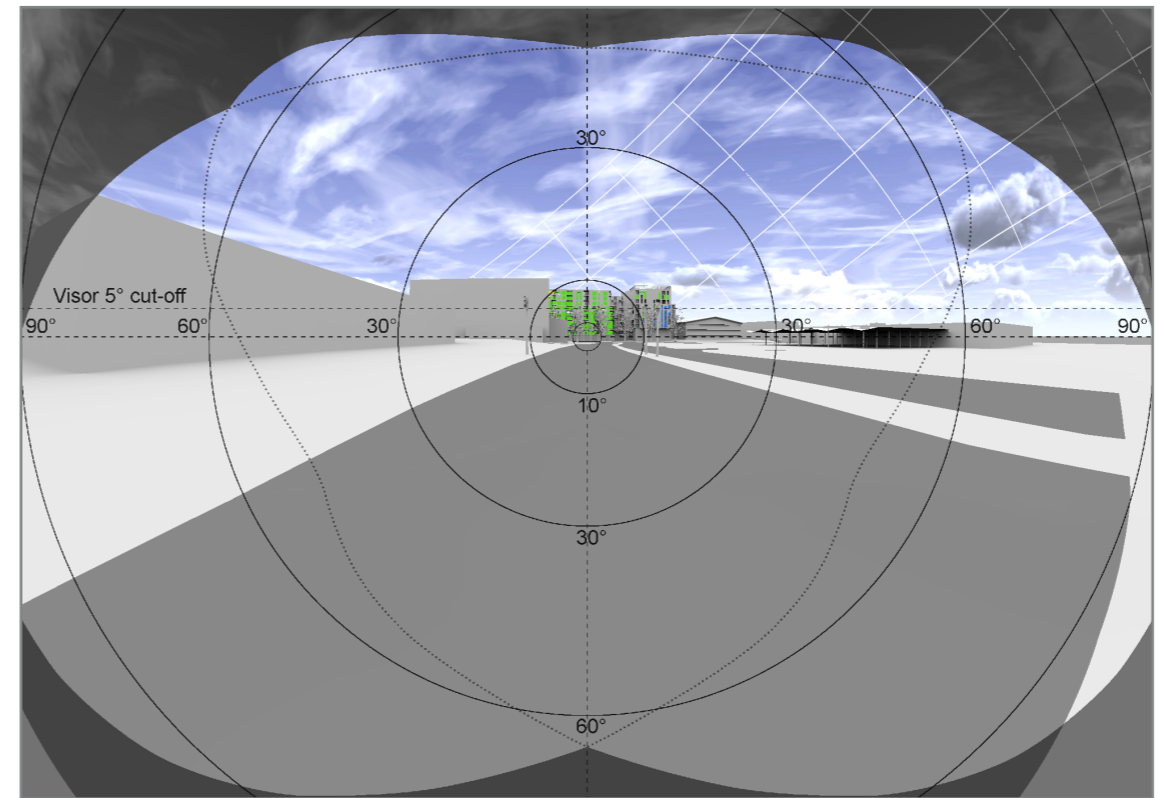

Fig. 42: Solar Glare - MONTHS - 180 degrees view

Project	Charlton Riverside Greenwich		
Reference	1864_R35_SG01		
Drawn	VL	Checked	JB
Date	29/11/2018	Rel no.	01
Drawing no.	1864_R35_SG01-11		

Title
 Reflected Solar Glare
 Frequency of Solar Reflections
 Proposed Scenario
 Trees in leaf
 Viewpoint V3A

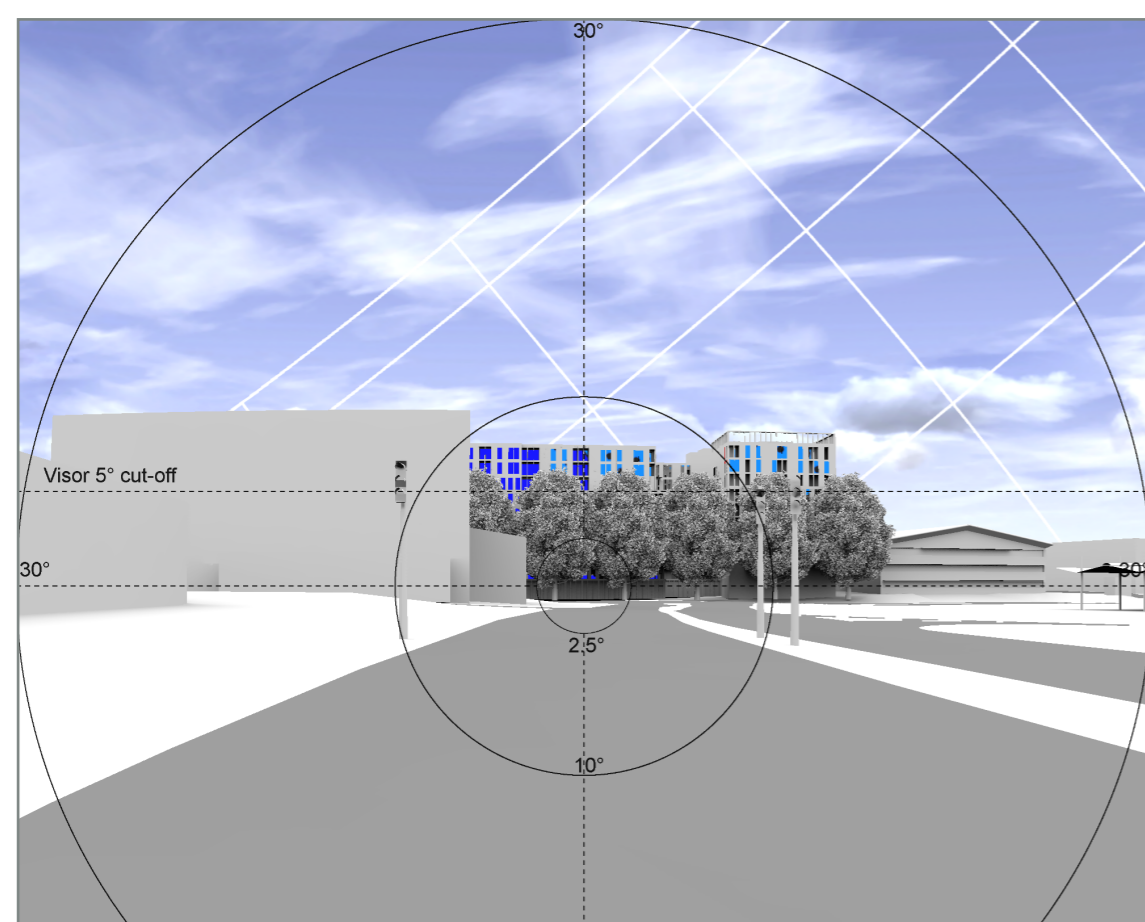

Fig. 43: Solar Glare - HOURS - Close-up

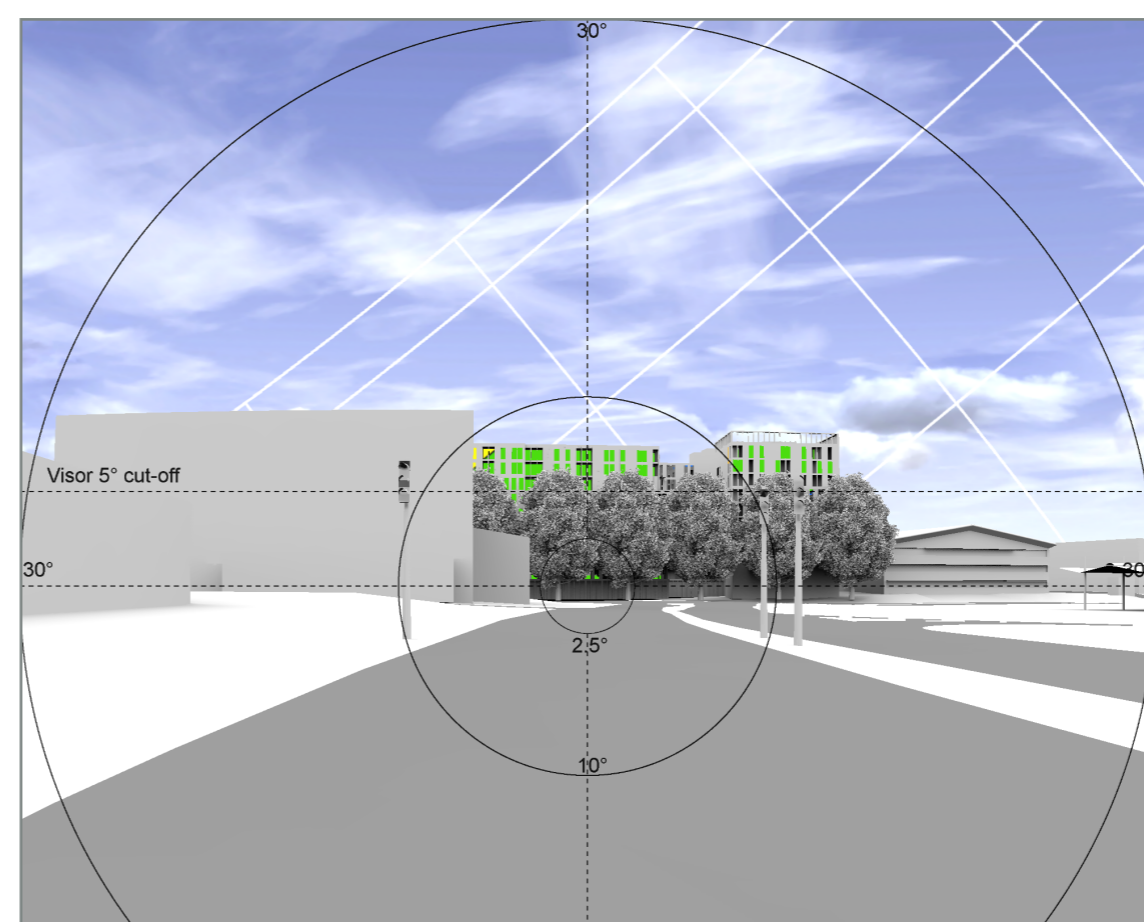
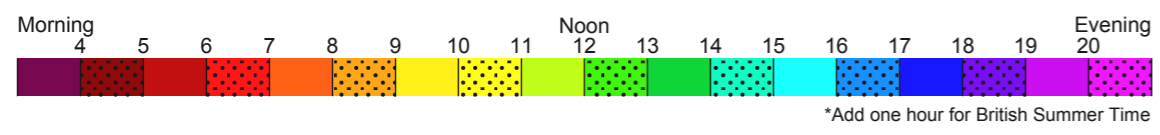

Fig. 44: Solar Glare - MONTHS - Close-up

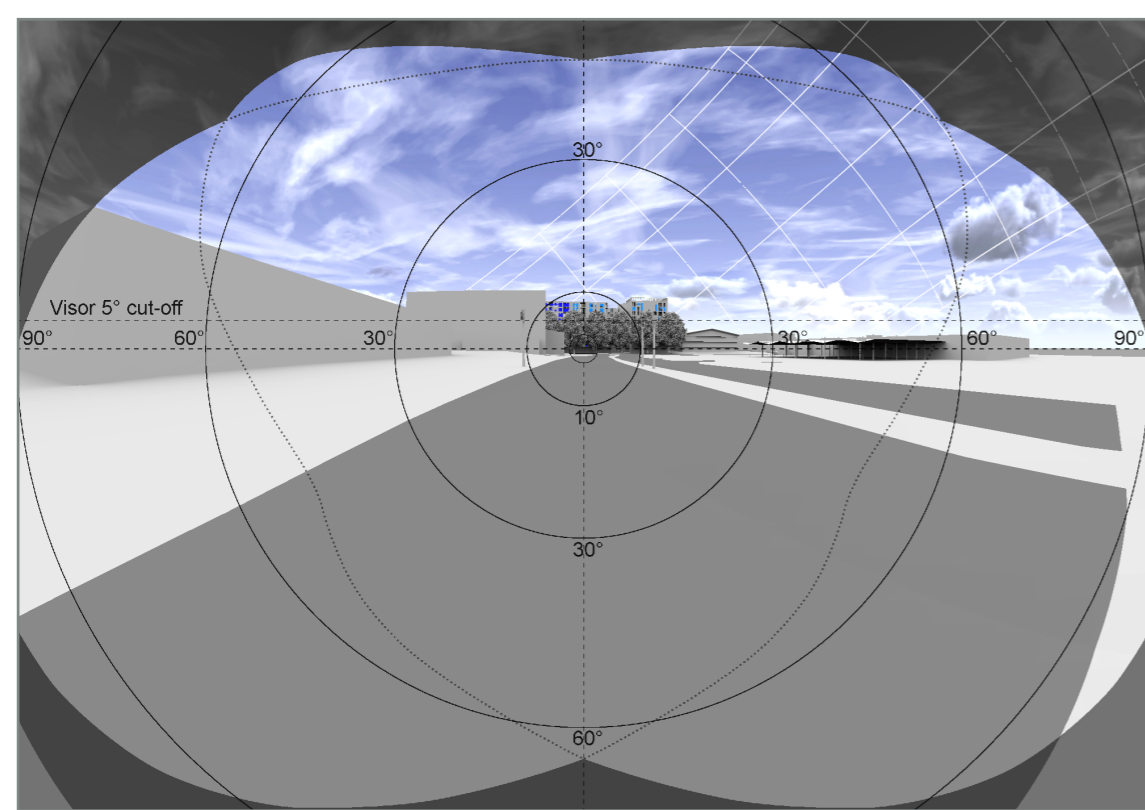
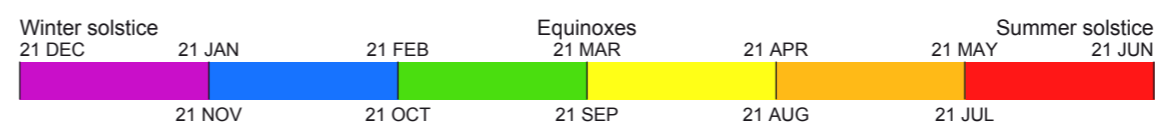

Fig. 45: Solar Glare - HOURS - 180 degrees view

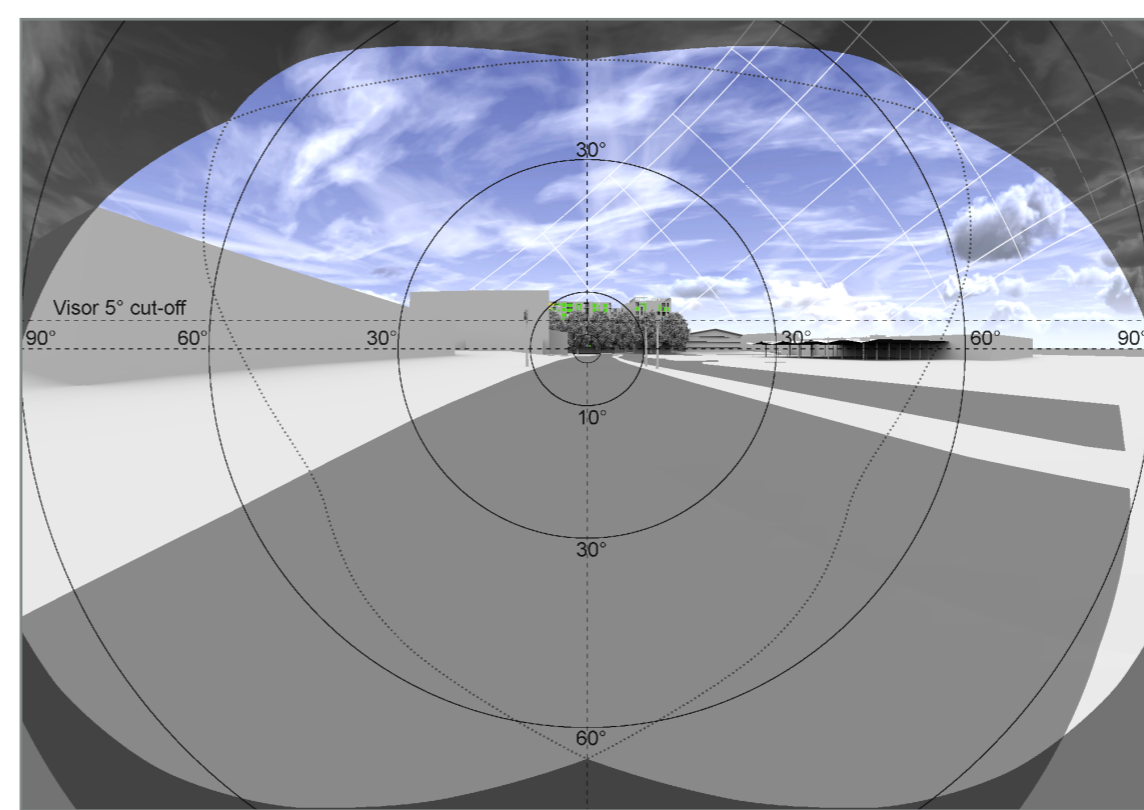

Fig. 46: Solar Glare - MONTHS - 180 degrees view

Project	Charlton Riverside Greenwich		
Reference	1864_R35_SG01		
Drawn	VL	Checked	JB
Date	29/11/2018	Rel no.	01
Drawing no.	1864_R35_SG01-12		

Title
 Reflected Solar Glare
 Frequency of Solar Reflections
 Existing Scenario
 Bare trees
 Viewpoint V3A

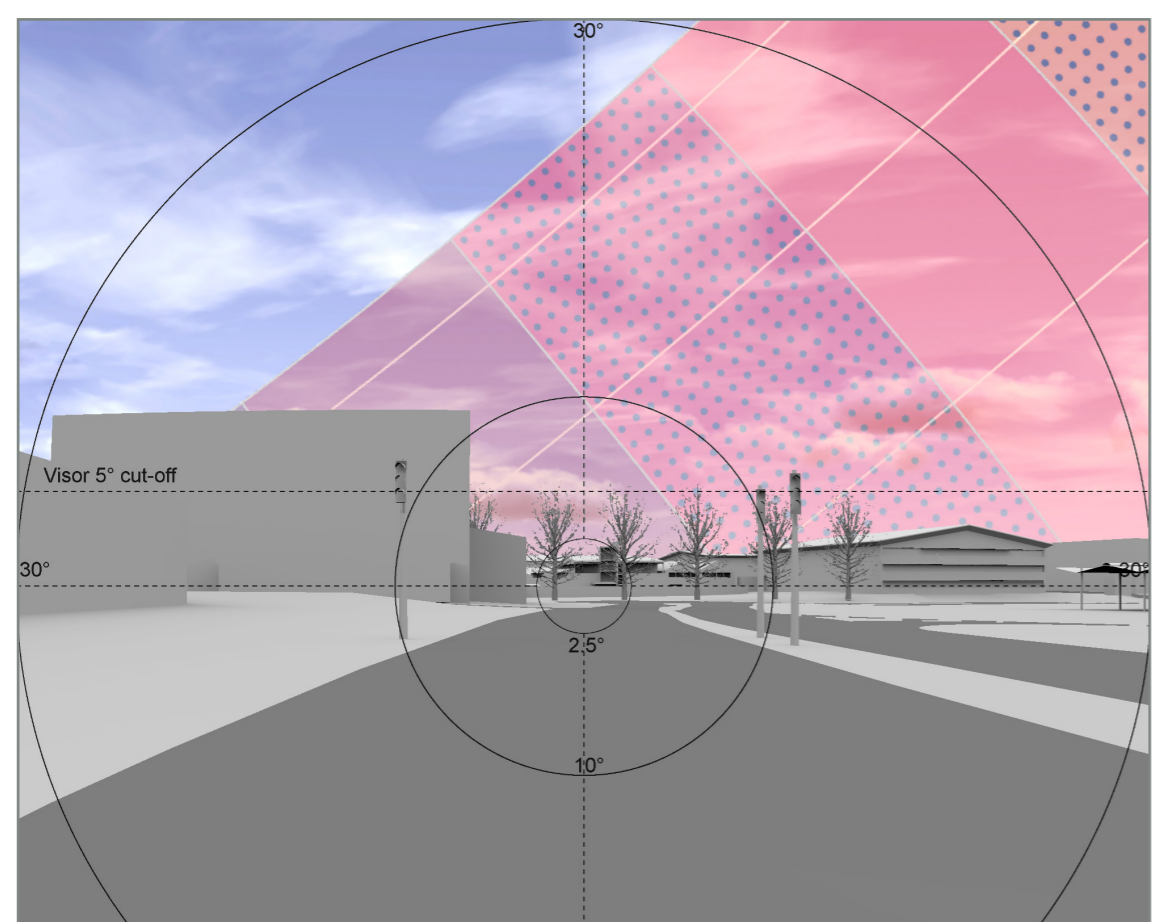

Fig. 47: Solar Glare - HOURS - Close-up

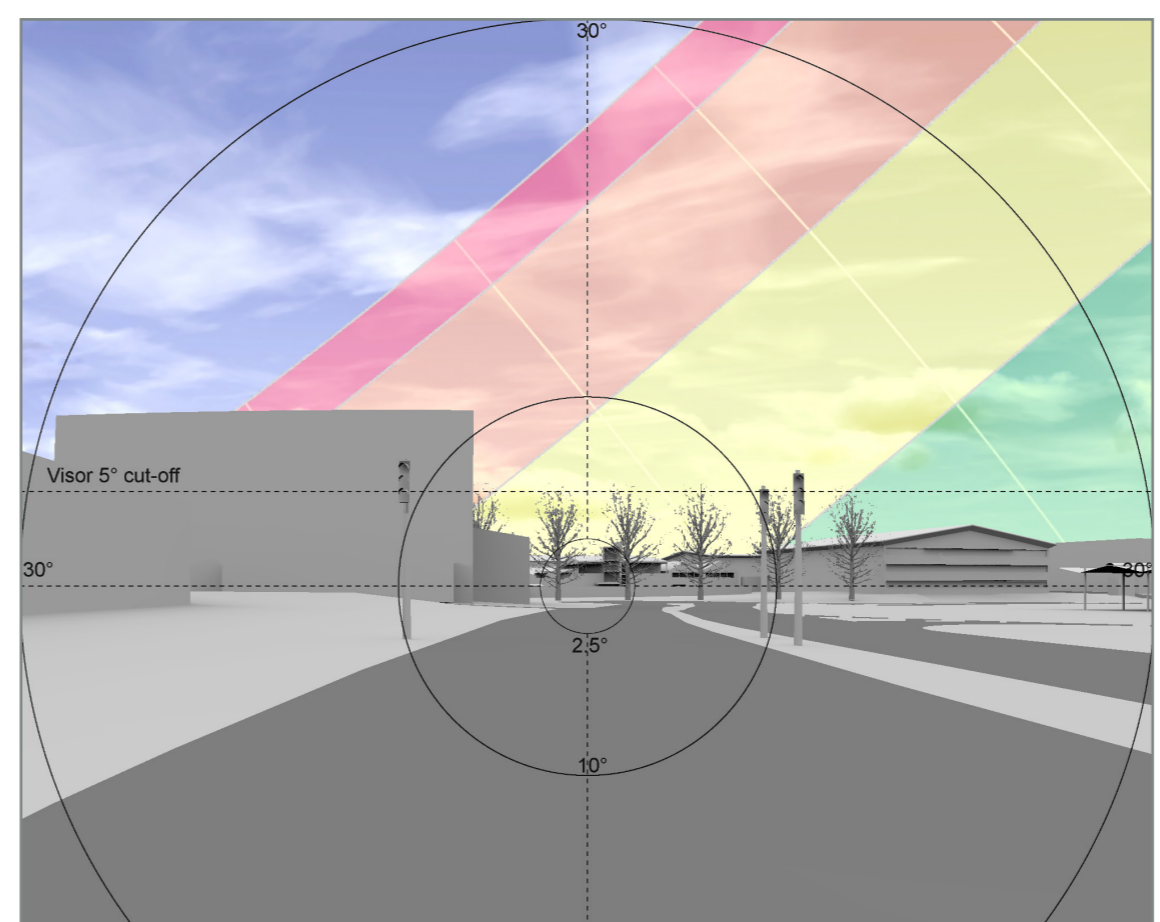
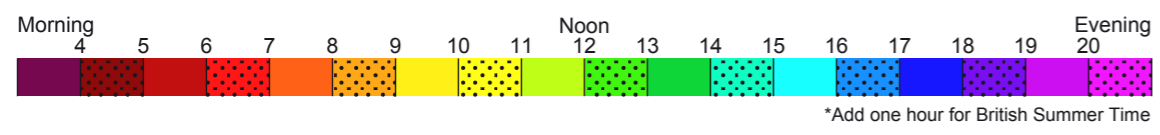

Fig. 48: Solar Glare - MONTHS - Close-up

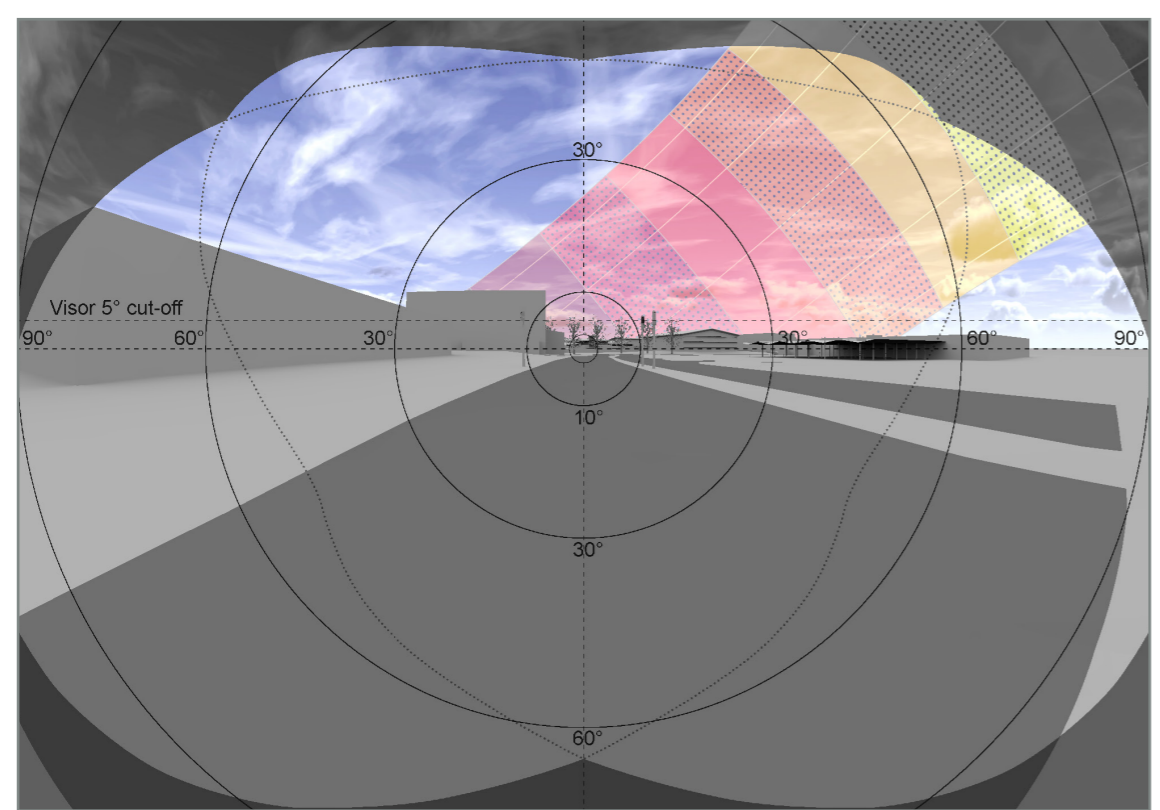
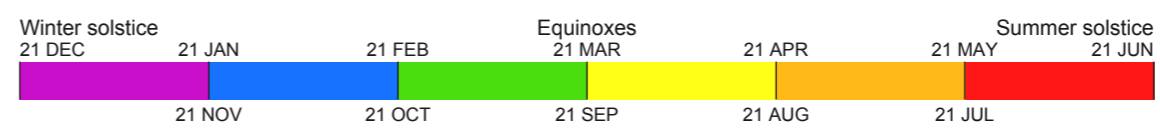

Fig. 49: Solar Glare - HOURS - 180 degrees view

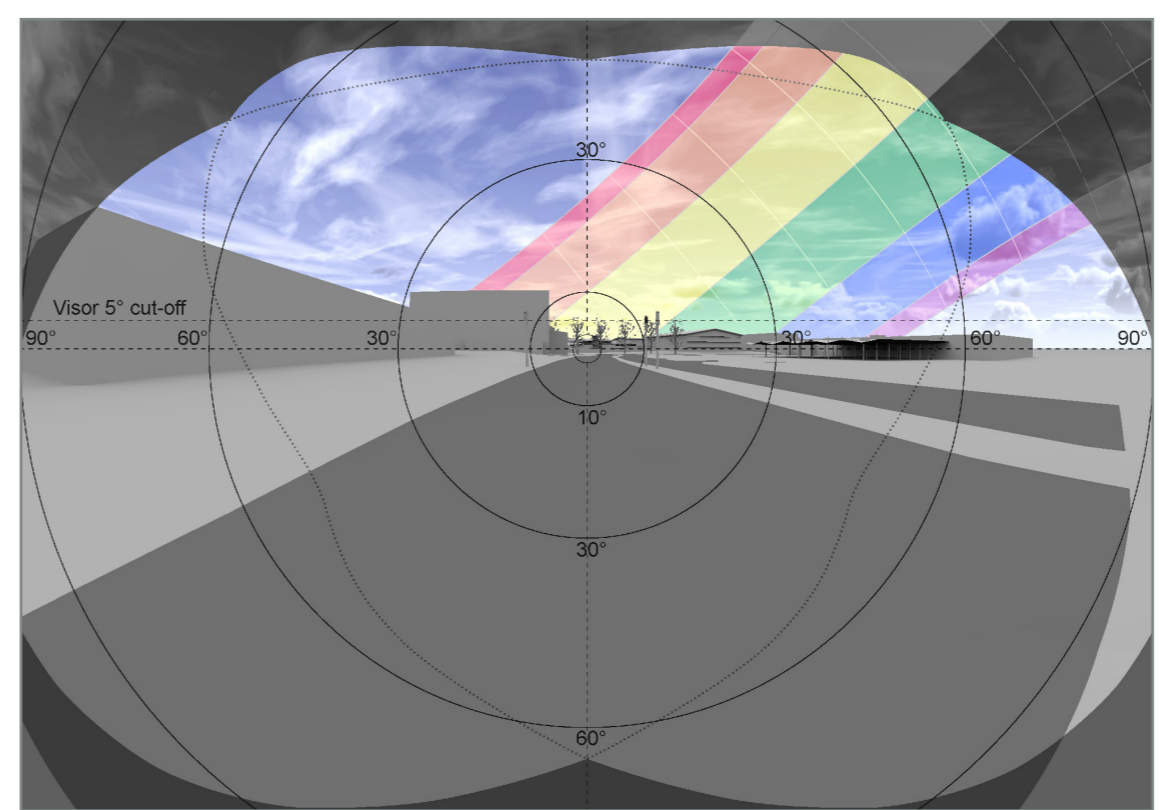

Fig. 50: Solar Glare - MONTHS - 180 degrees view

Project	Charlton Riverside Greenwich		
Reference	1864_R35_SG01		
Drawn	VL	Checked	JB
Date	29/11/2018	Rel no.	01
Drawing no.	1864_R35_SG01-13		

Title
 Reflected Solar Glare
 Frequency of Solar Reflections
 Proposed Scenario
 Bare trees
 Viewpoint V3B

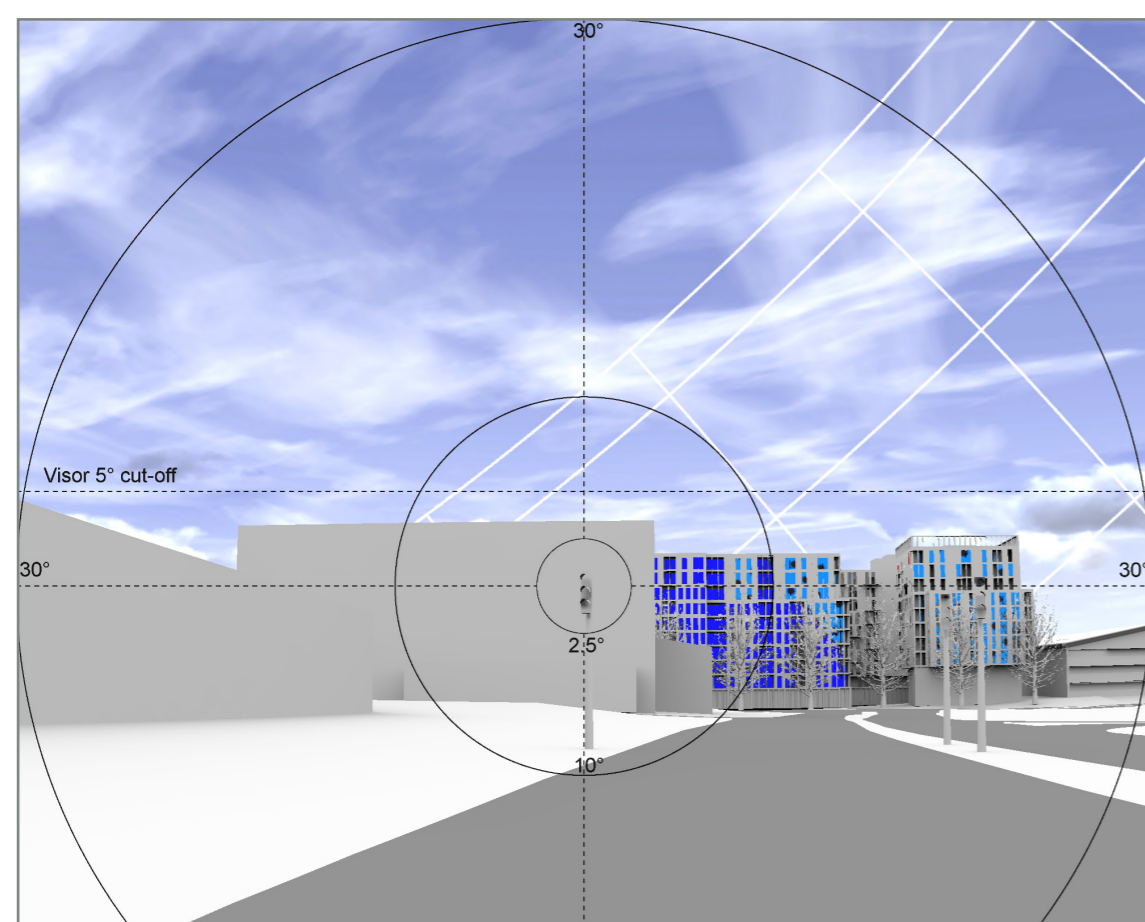

Fig. 51: Solar Glare - HOURS - Close-up

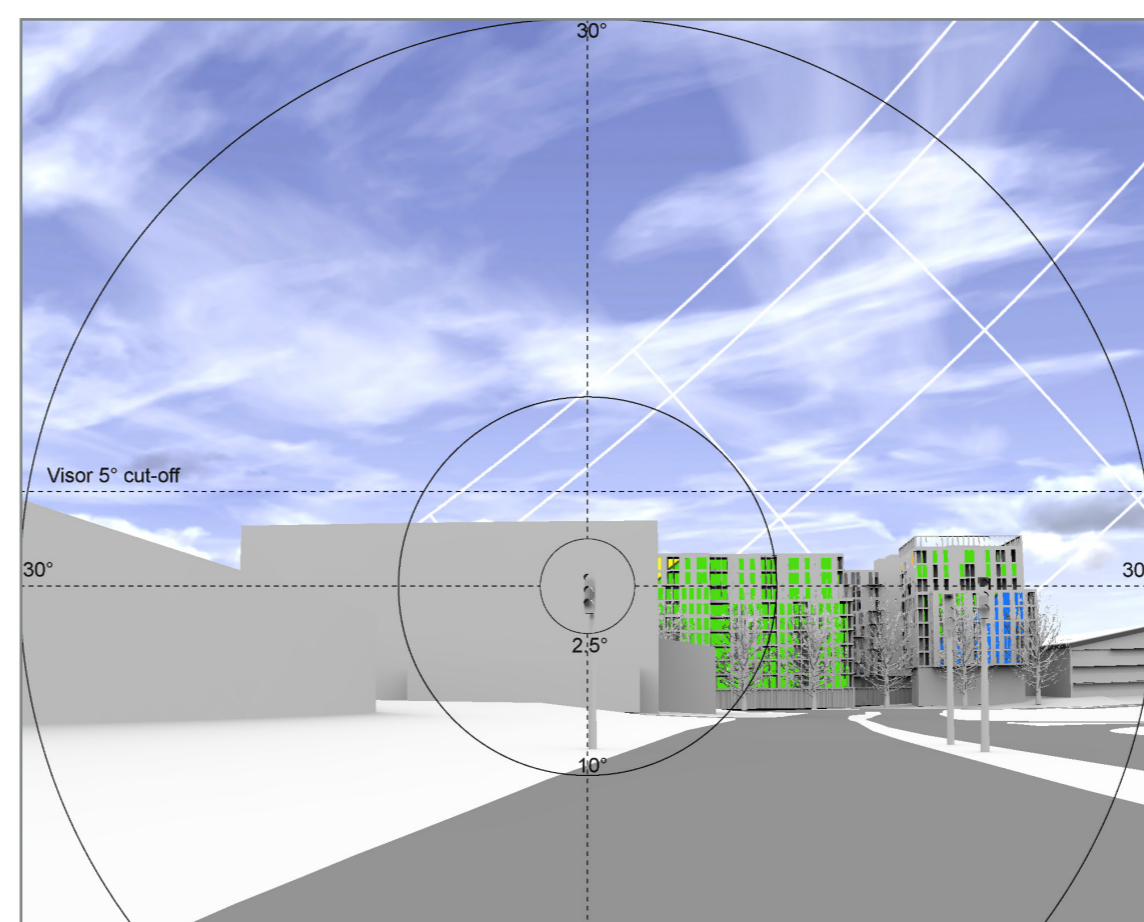
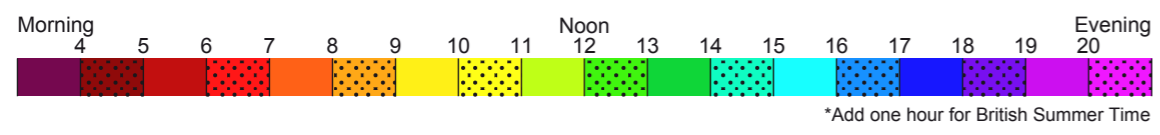

Fig. 52: Solar Glare - MONTHS - Close-up

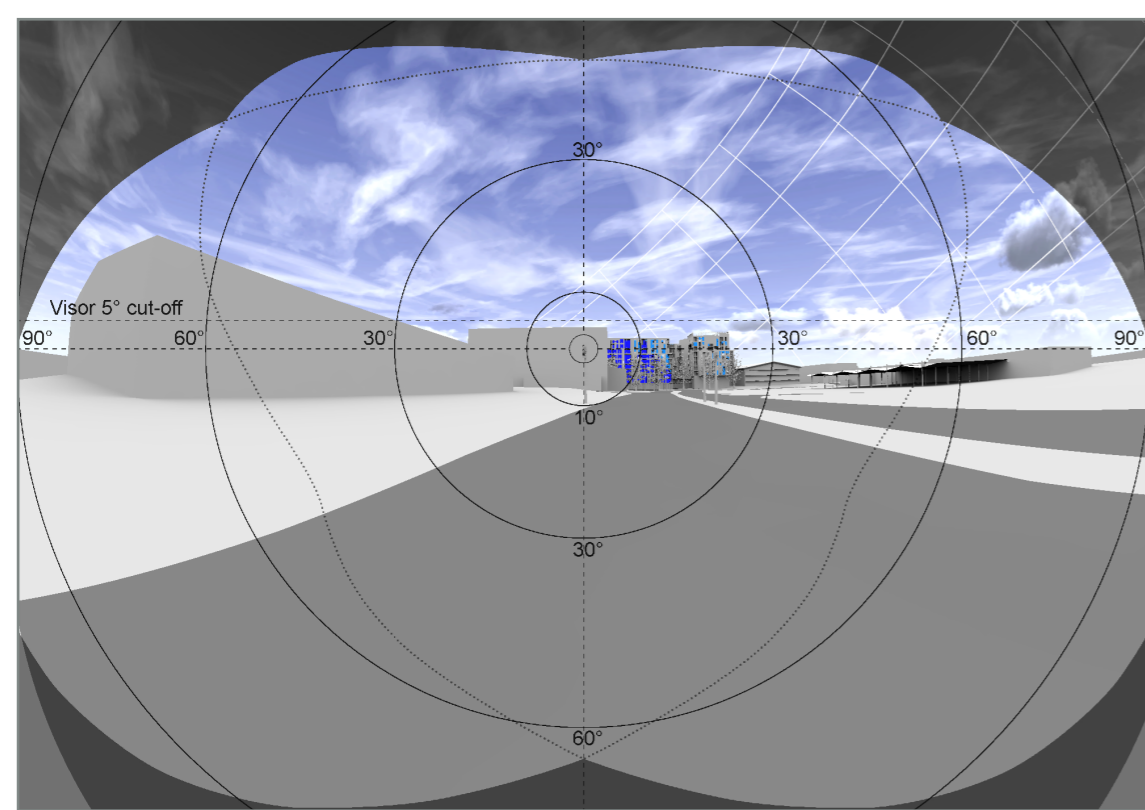
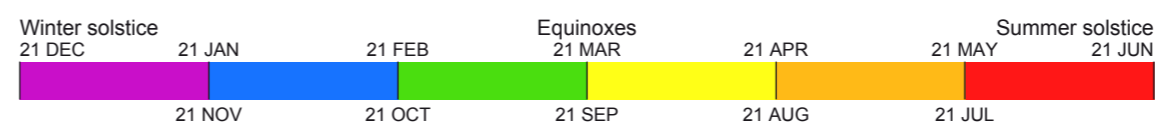

Fig. 53: Solar Glare - HOURS - 180 degrees view

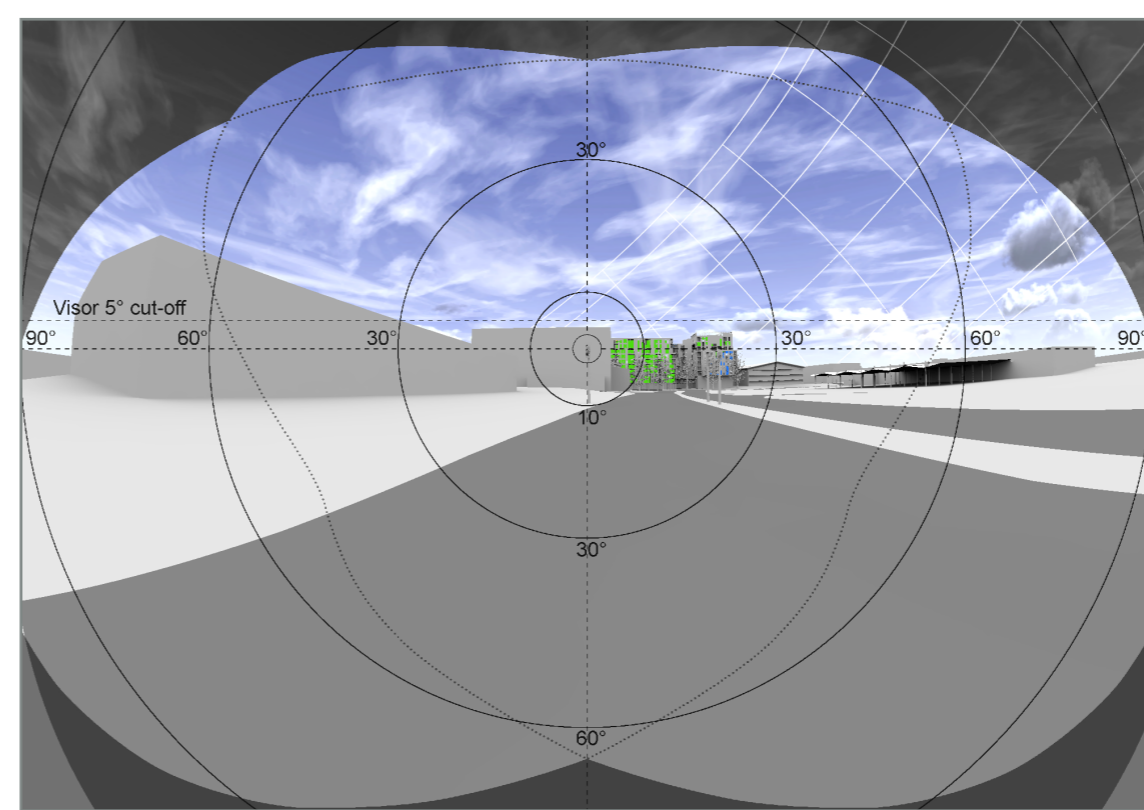

Fig. 54: Solar Glare - MONTHS - 180 degrees view

Project	Charlton Riverside Greenwich		
Reference	1864_R35_SG01		
Drawn	VL	Checked	JB
Date	29/11/2018	Rel no.	01
Drawing no.	1864_R35_SG01-14		

Title
 Reflected Solar Glare
 Frequency of Solar Reflections
 Proposed Scenario
 Trees in leaf
 Viewpoint V3B

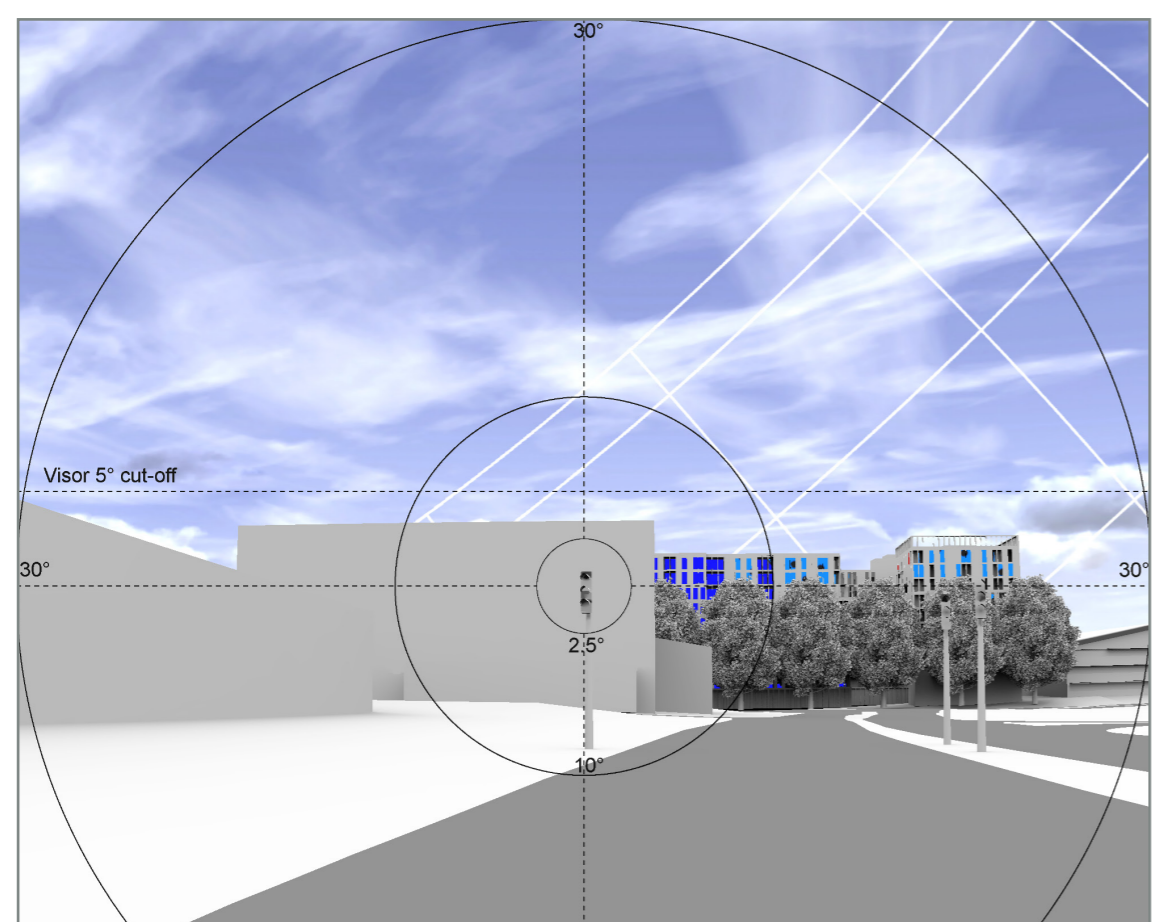

Fig. 55: Solar Glare - HOURS - Close-up

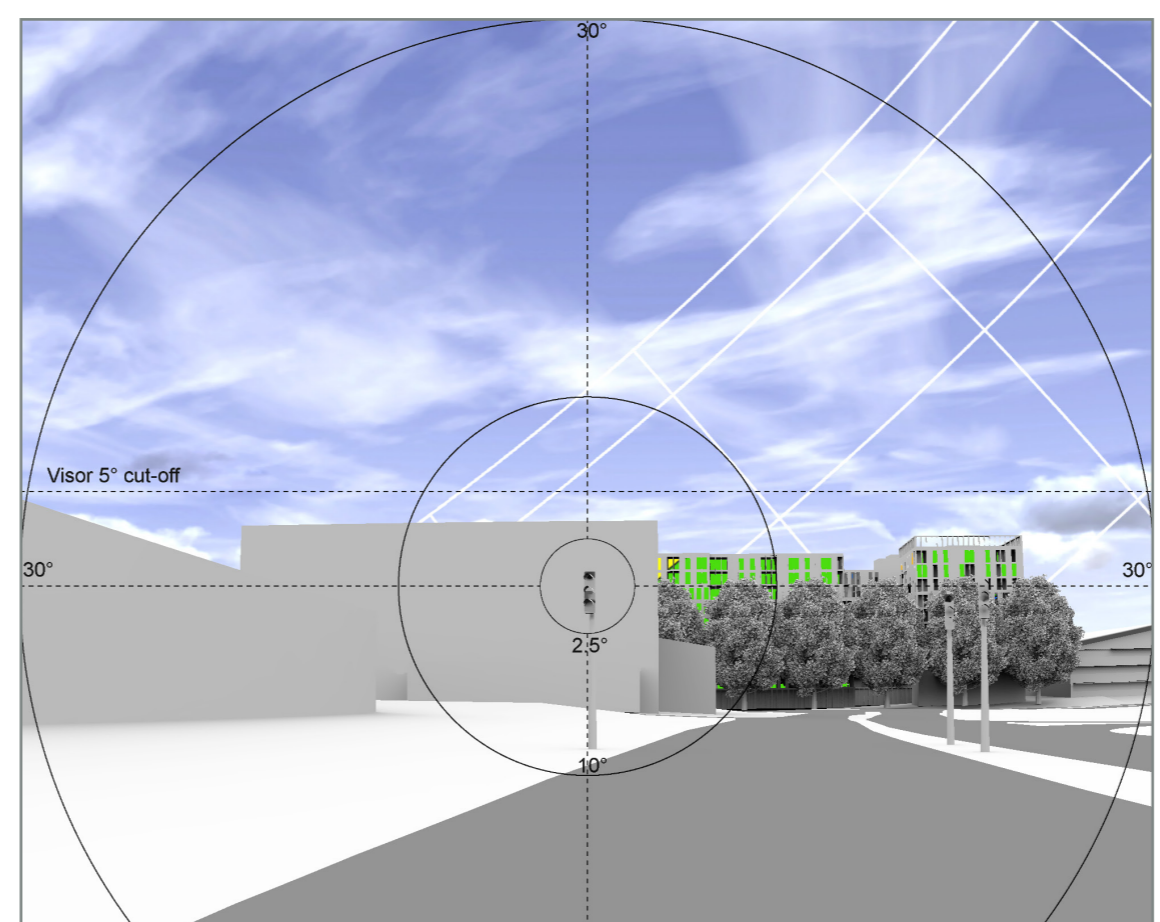
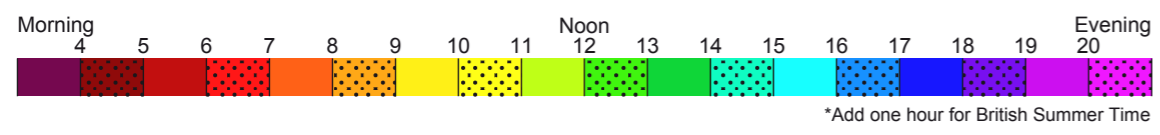

Fig. 56: Solar Glare - MONTHS - Close-up

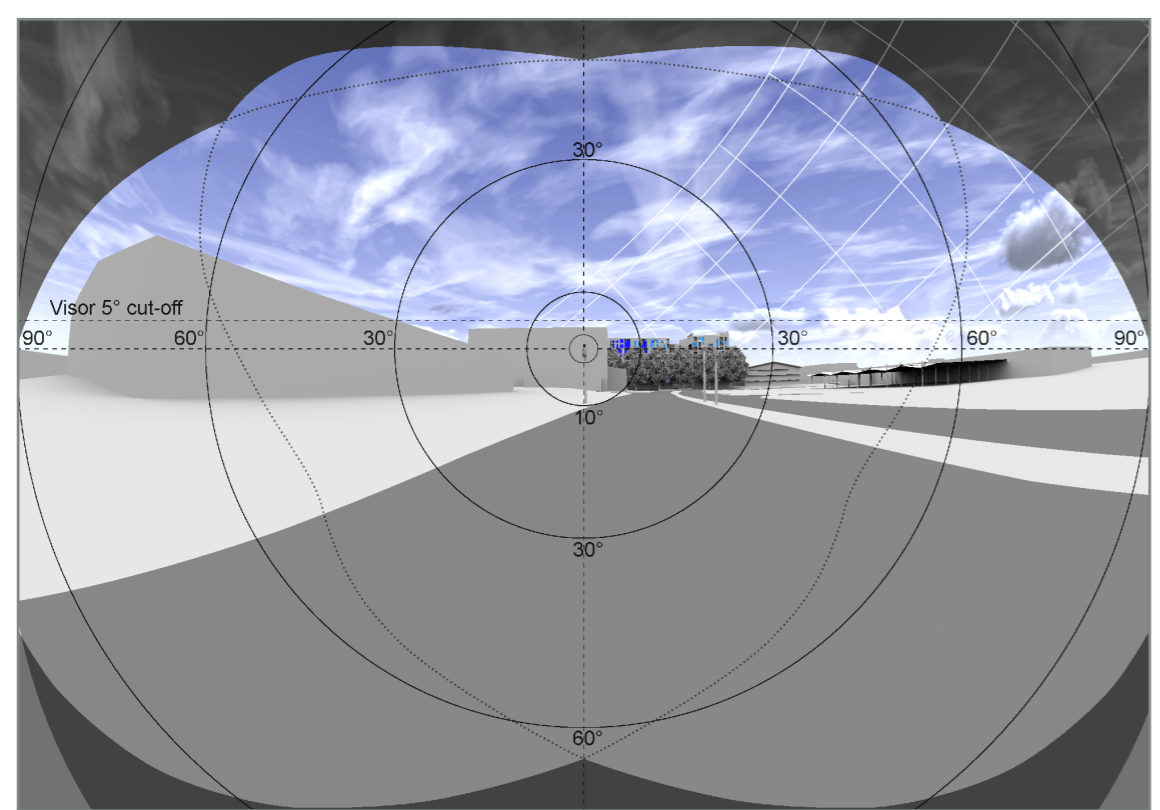
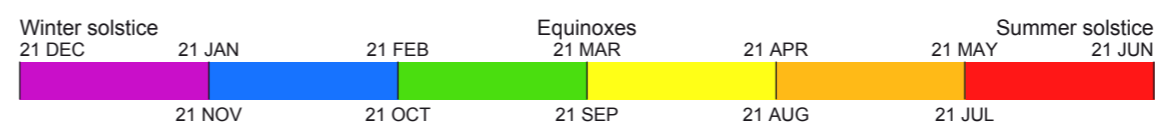

Fig. 57: Solar Glare - HOURS - 180 degrees view

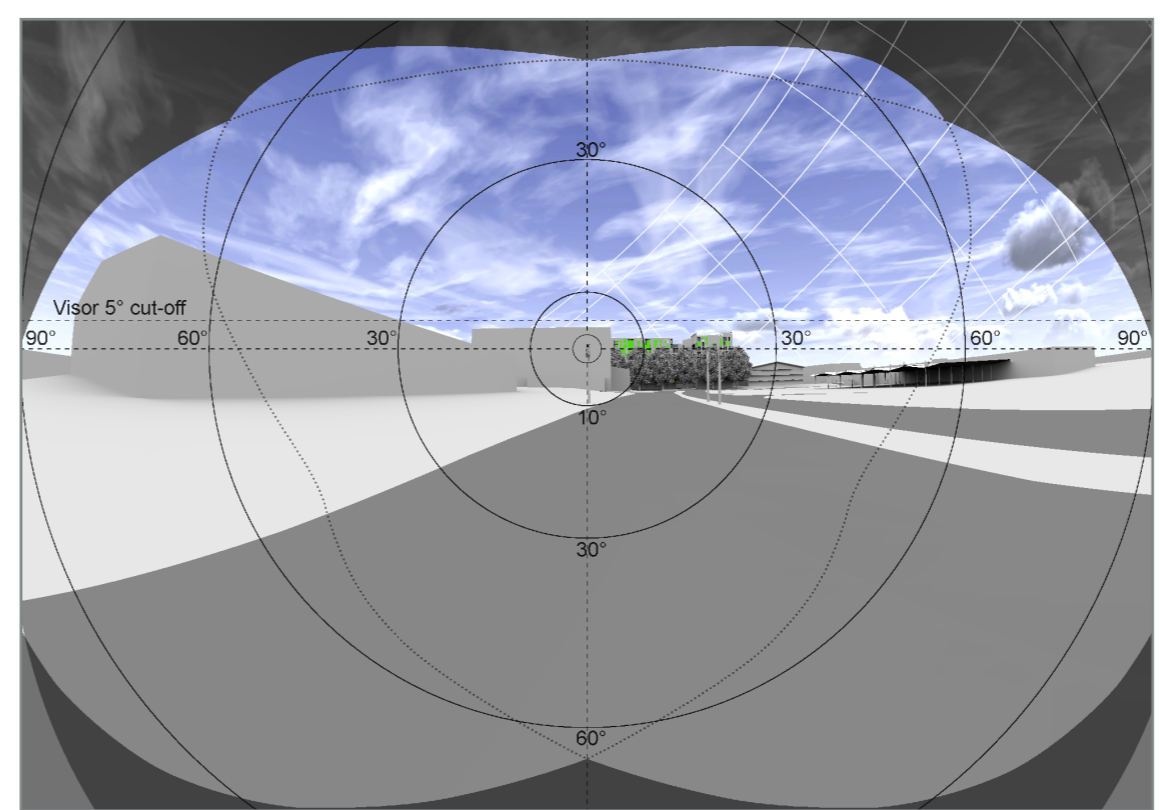

Fig. 58: Solar Glare - MONTHS - 180 degrees view

Project	Charlton Riverside Greenwich		
Reference	1864_R35_SG01		
Drawn	VL	Checked	JB
Date	29/11/2018	Rel no.	01
Drawing no.	1864_R35_SG01-15		

Title
 Reflected Solar Glare
 Frequency of Solar Reflections
 Existing Scenario
 Bare trees
 Viewpoint V3B

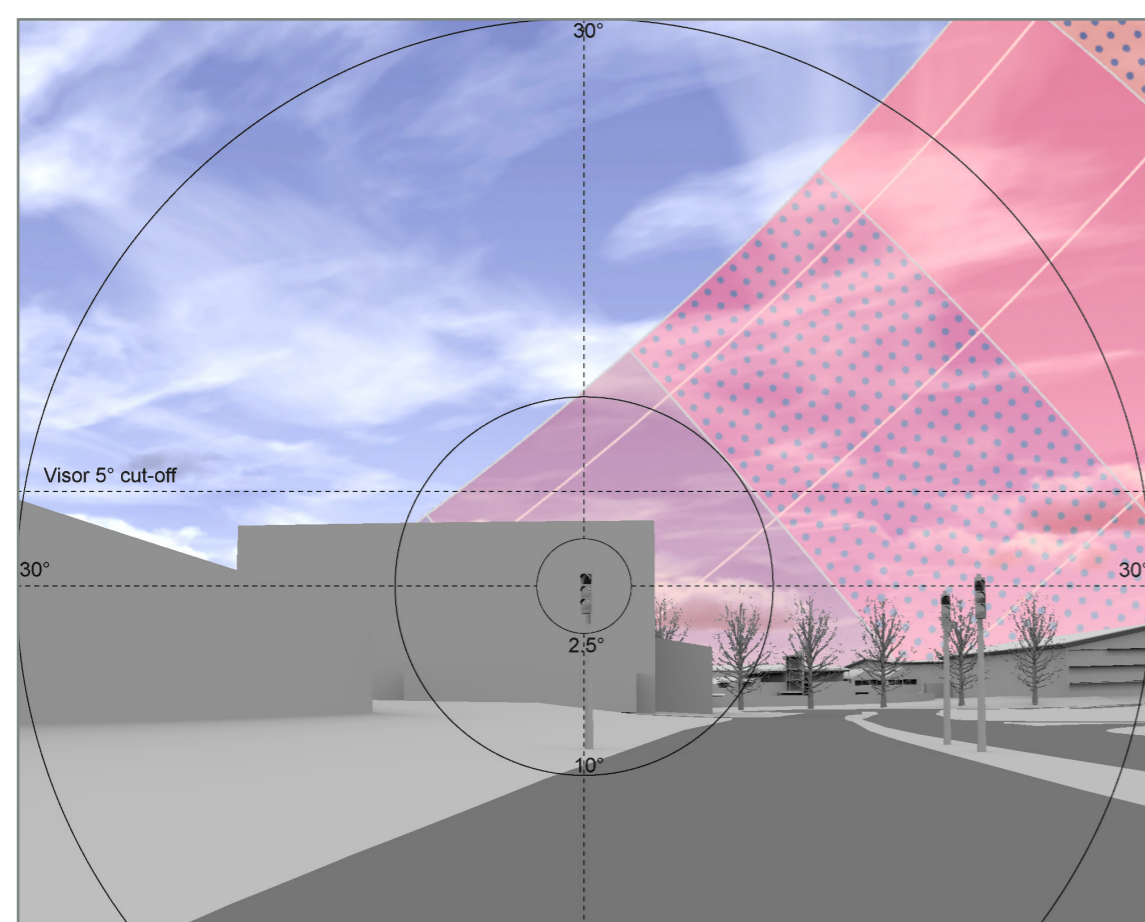

Fig. 59: Solar Glare - HOURS - Close-up

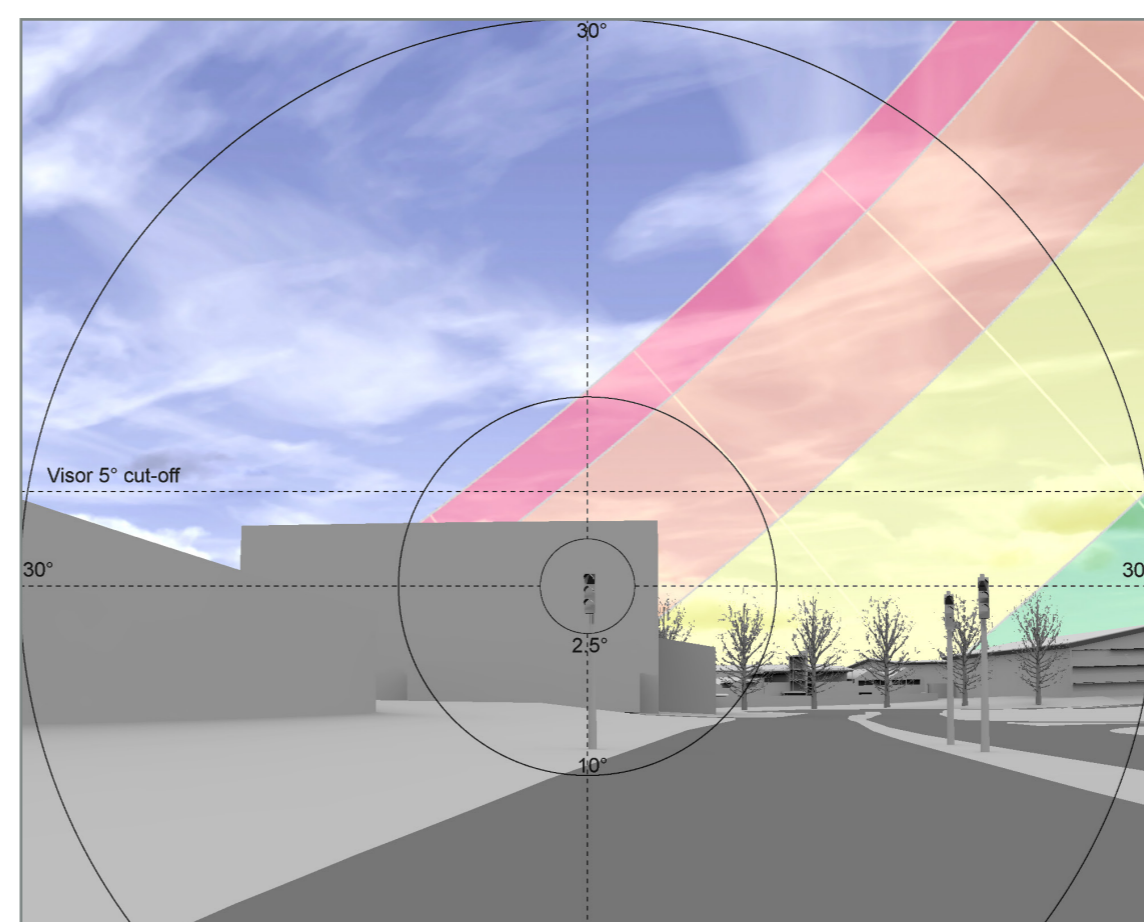
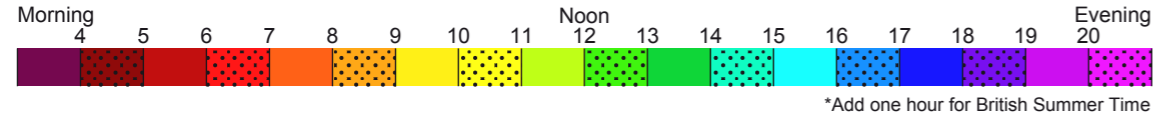

Fig. 60: Solar Glare - MONTHS - Close-up

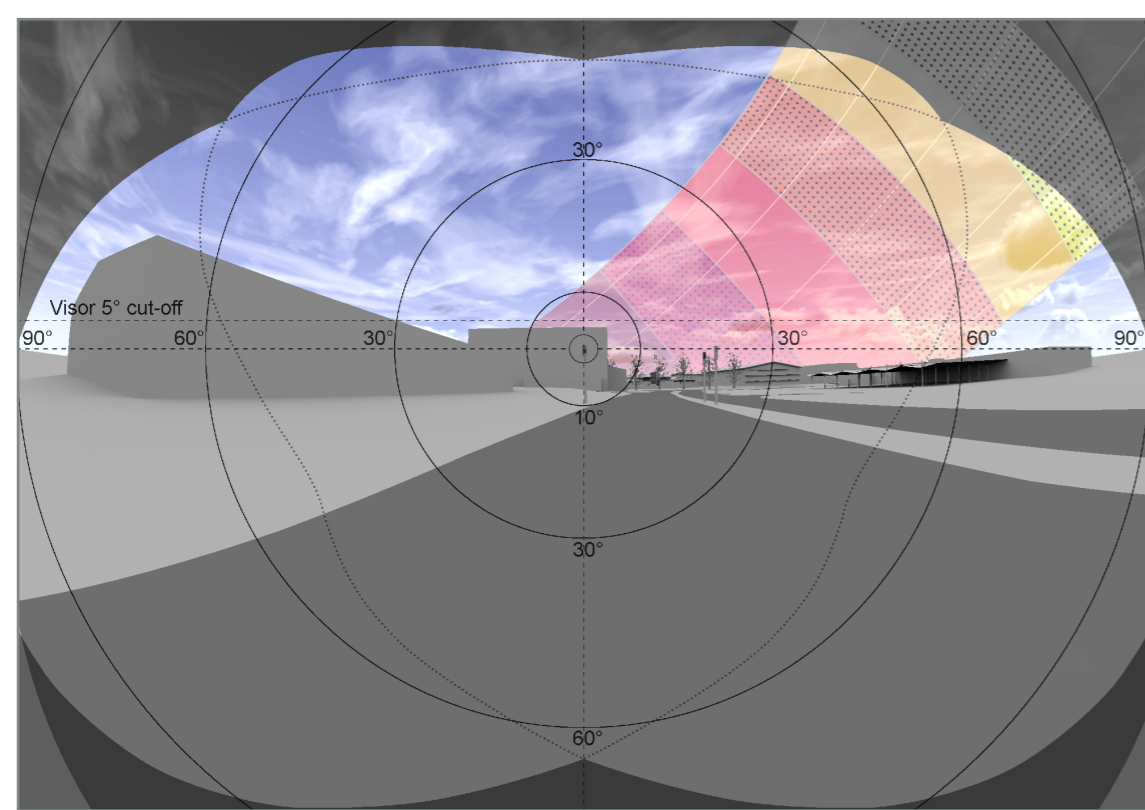
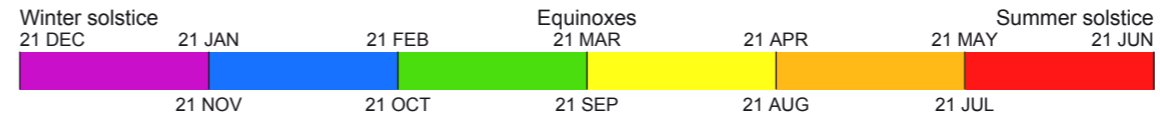

Fig. 61: Solar Glare - HOURS - 180 degrees view

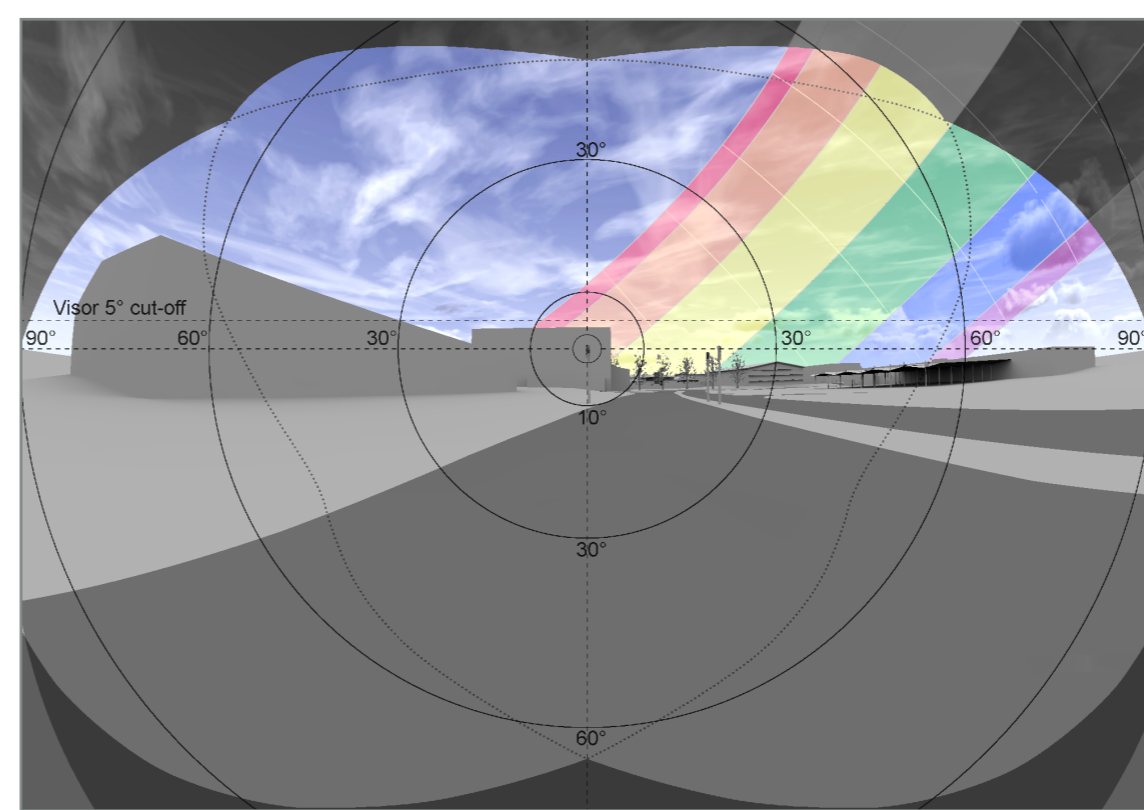

Fig. 62: Solar Glare - MONTHS - 180 degrees view

Project	Charlton Riverside Greenwich		
Reference	1864_R35_SG01		
Drawn	VL	Checked	JB
Date	29/11/2018	Rel no.	01
Drawing no.	1864_R35_SG01-16		

Title
 Reflected Solar Glare
 Frequency of Solar Reflections
 Proposed Scenario
 Bare trees
 Viewpont V3C

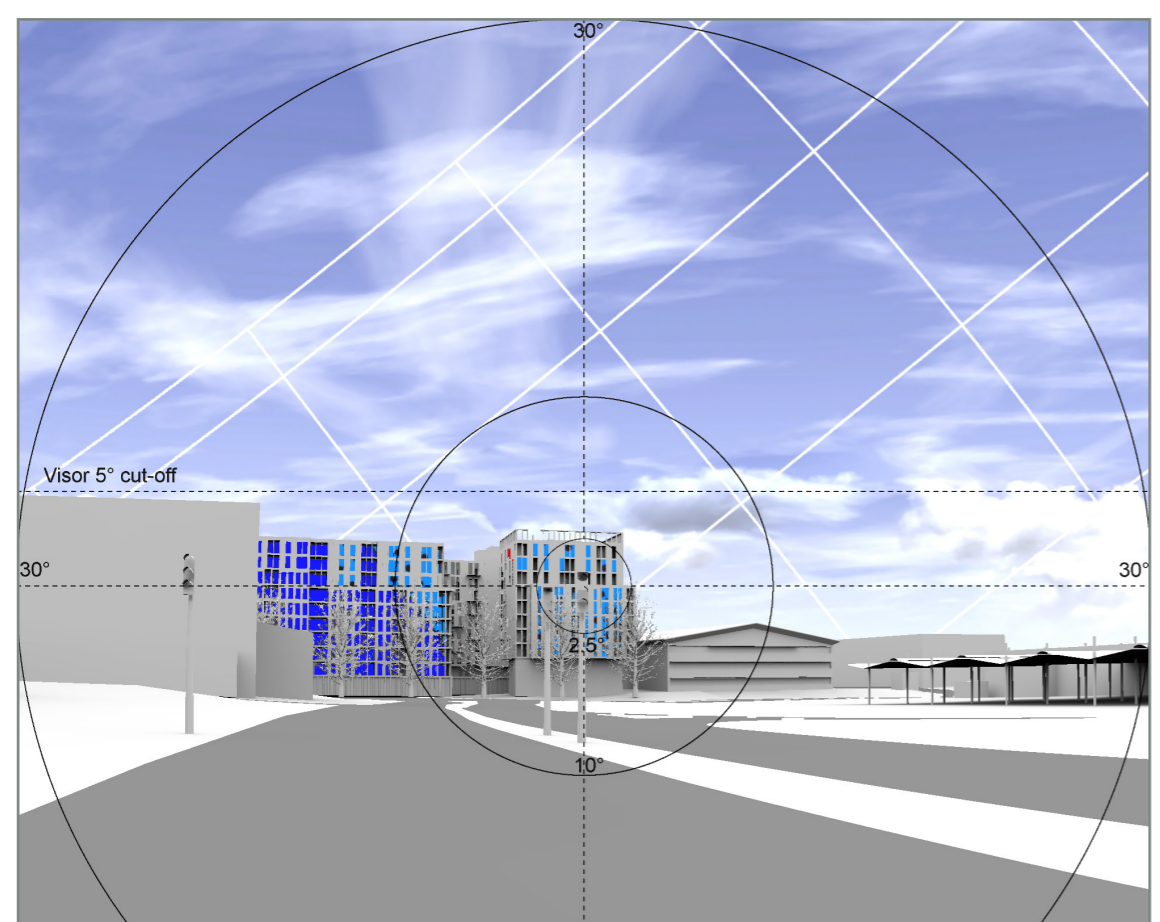

Fig. 63: Solar Glare - HOURS - Close-up

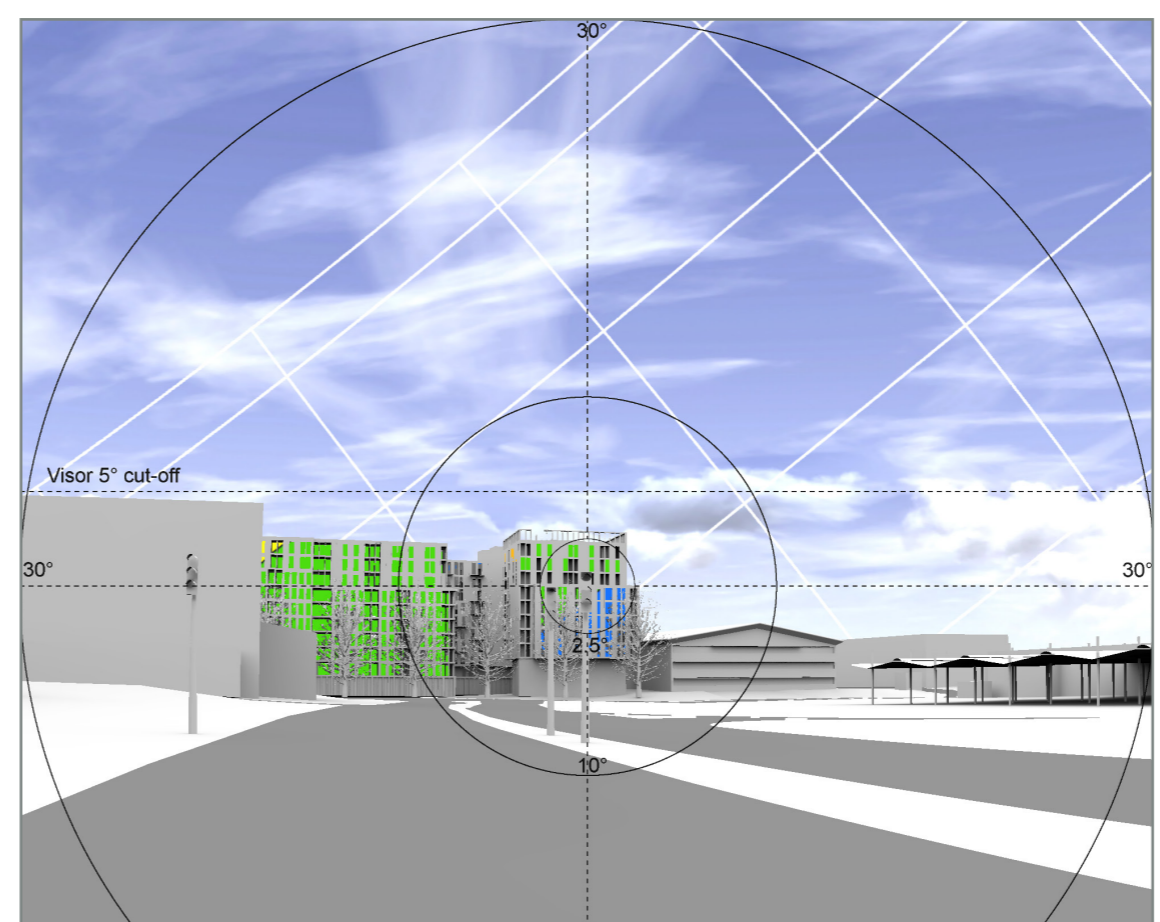
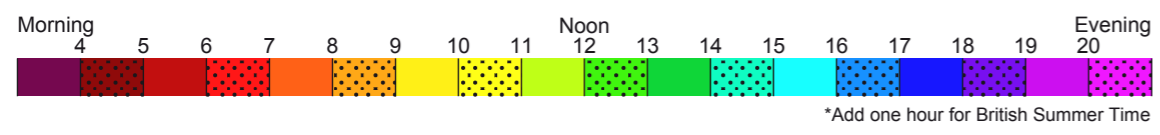

Fig. 64: Solar Glare - MONTHS - Close-up

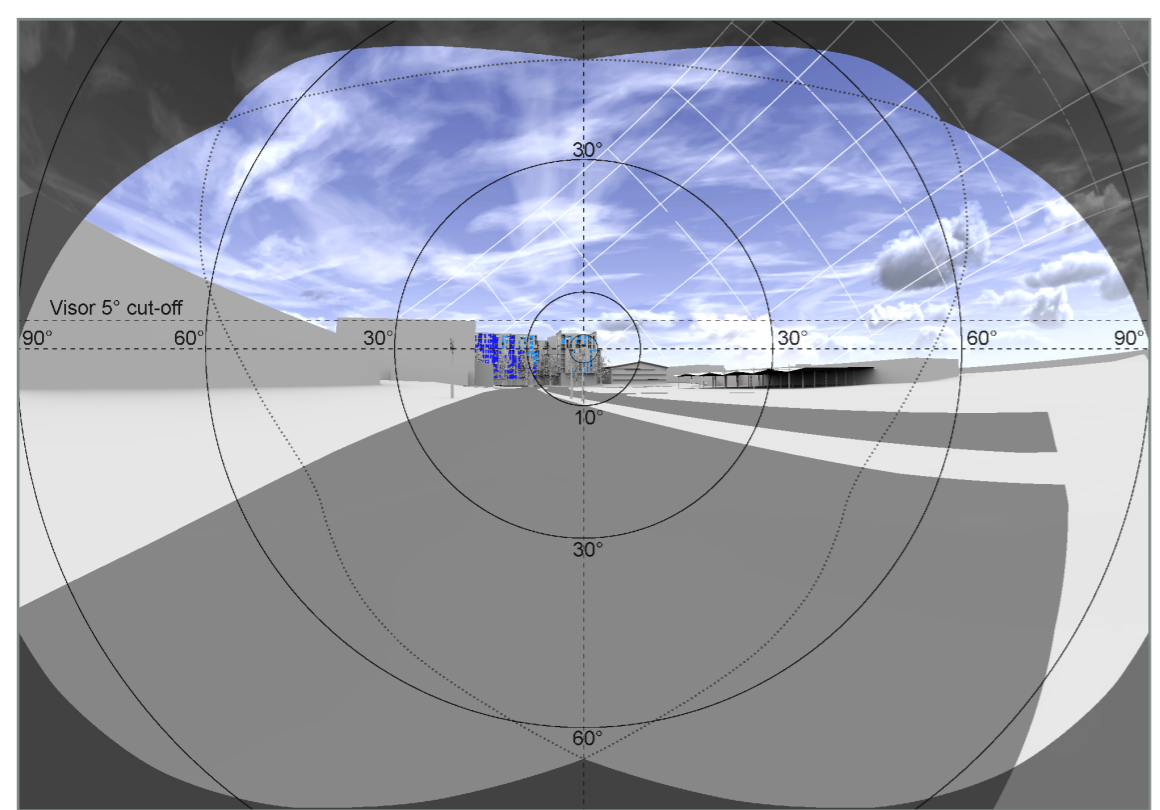
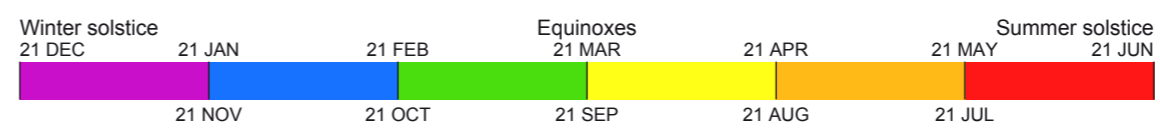

Fig. 65: Solar Glare - HOURS - 180 degrees view

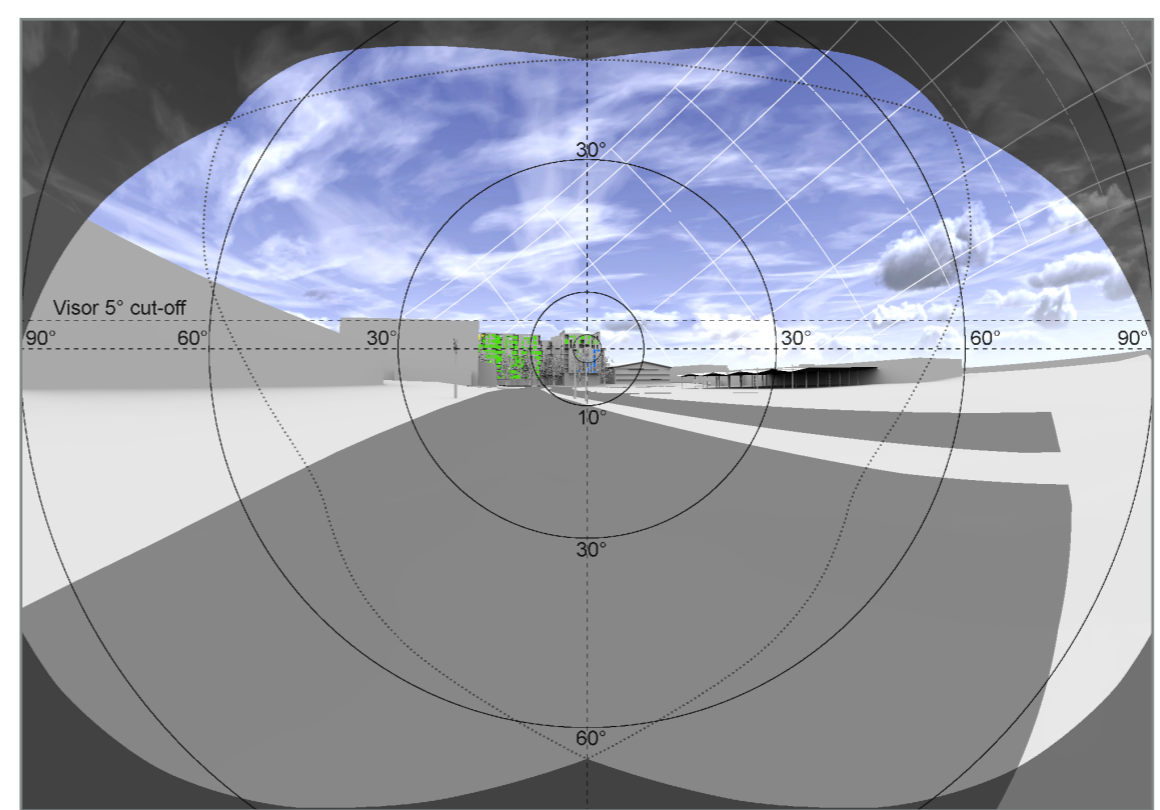

Fig. 66: Solar Glare - MONTHS - 180 degrees view

Project	Charlton Riverside Greenwich		
Reference	1864_R35_SG01		
Drawn	VL	Checked	JB
Date	29/11/2018	Rel no.	01
Drawing no.	1864_R35_SG01-17		

Title
 Reflected Solar Glare
 Frequency of Solar Reflections
 Proposed Scenario
 Trees in leaf
 Viewpoint V3C

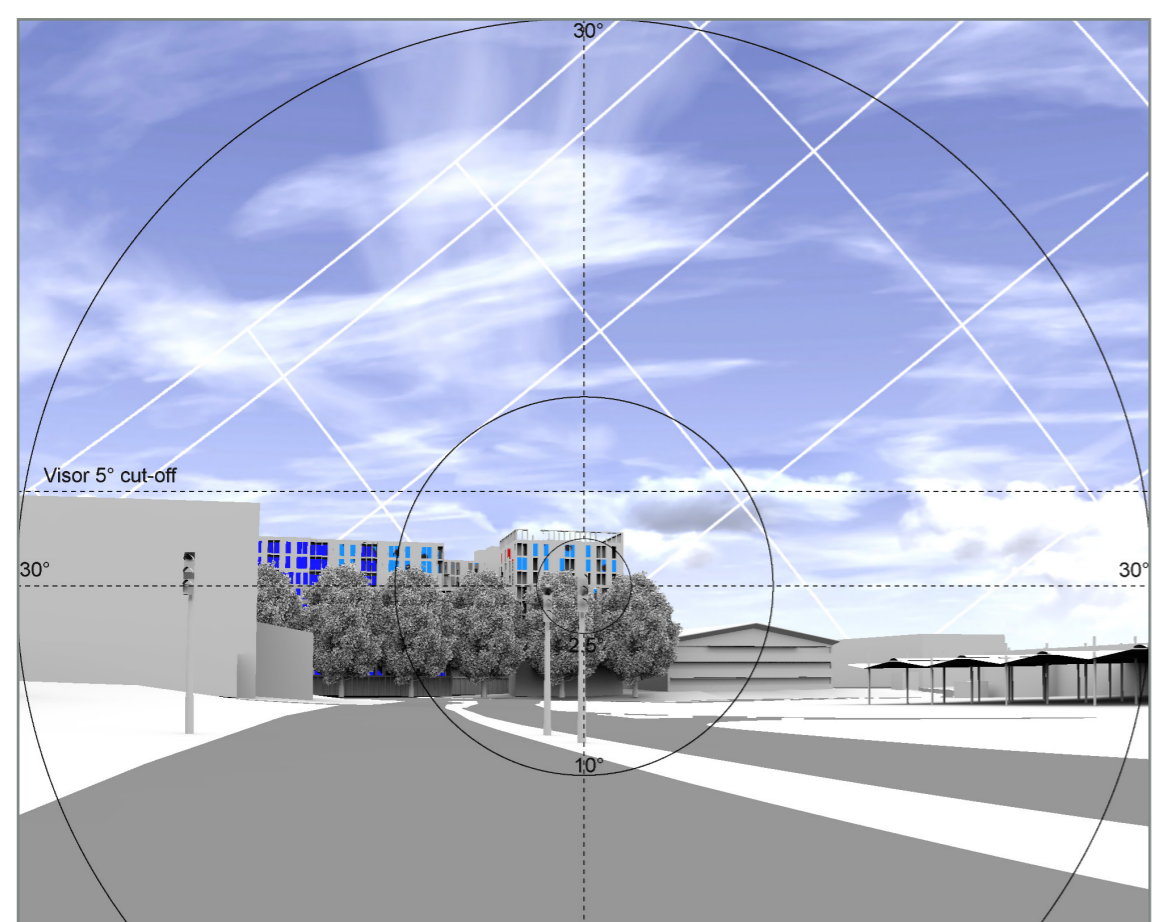

Fig. 67: Solar Glare - HOURS - Close-up

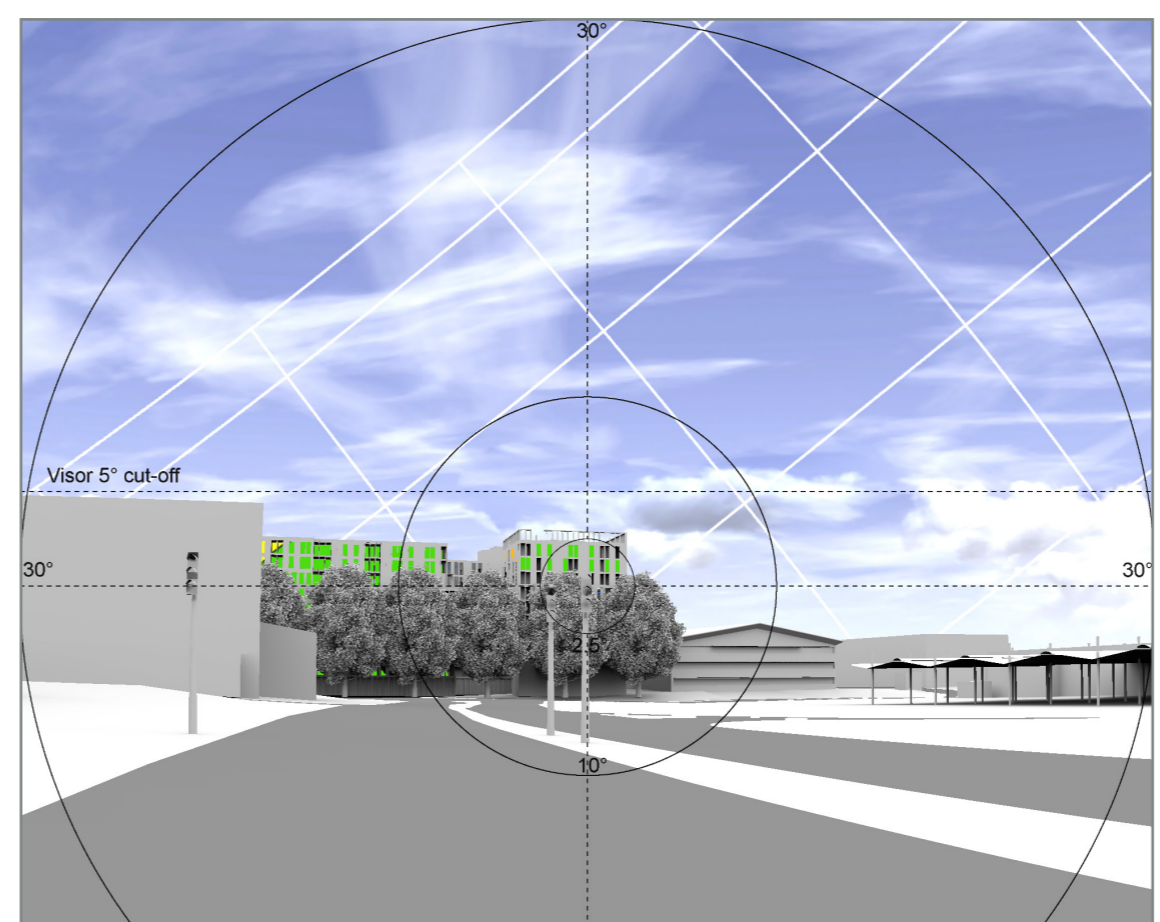
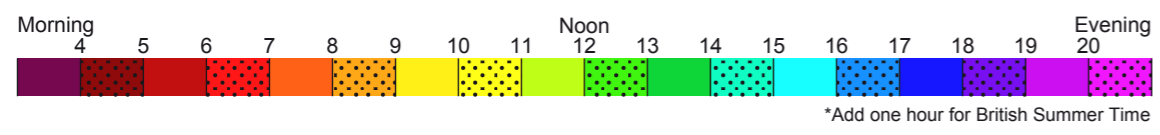

Fig. 68: Solar Glare - MONTHS - Close-up

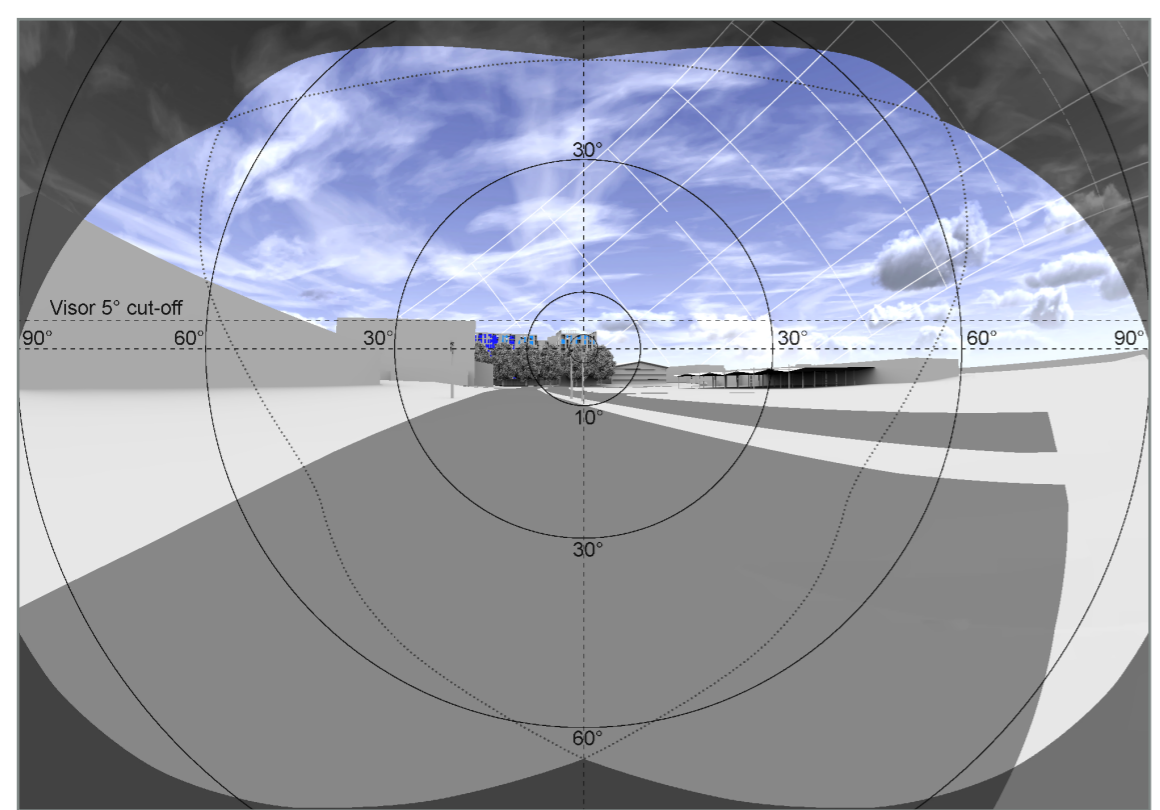
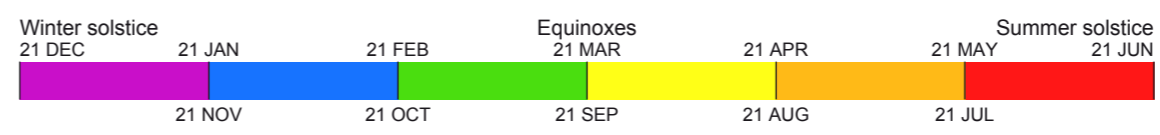

Fig. 69: Solar Glare - HOURS - 180 degrees view

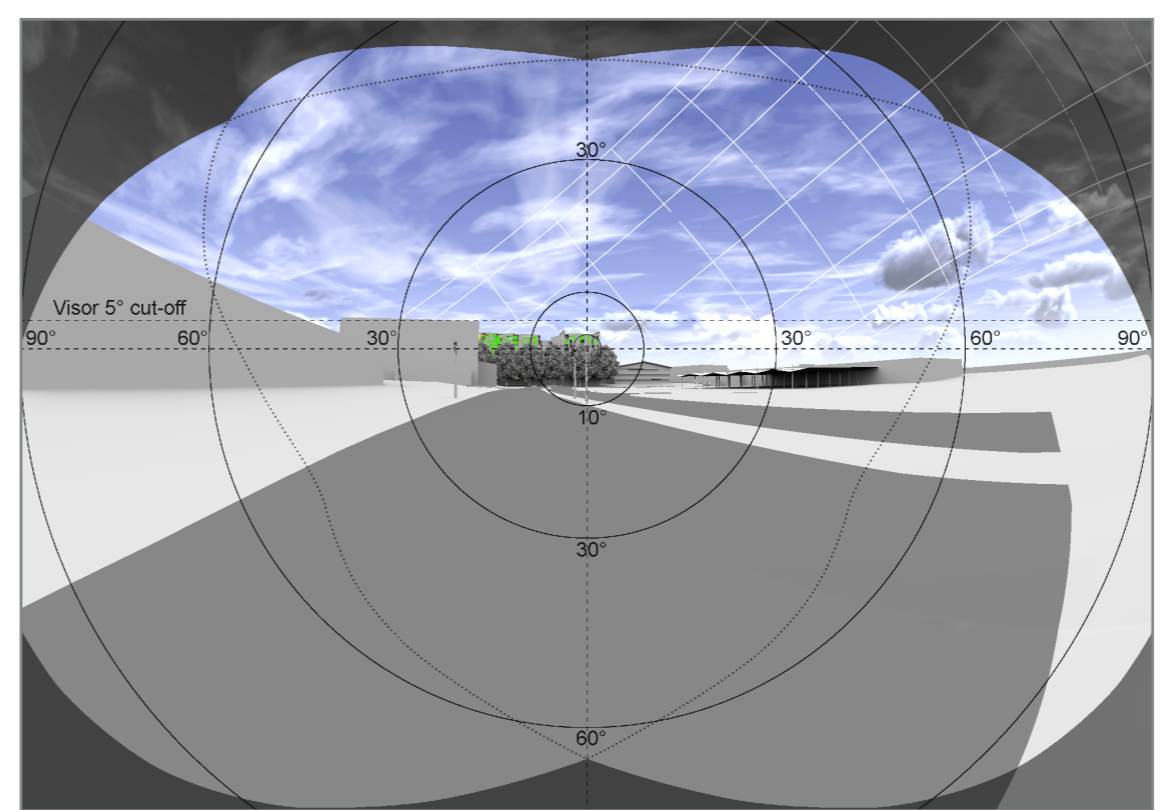

Fig. 70: Solar Glare - MONTHS - 180 degrees view

Project	Charlton Riverside Greenwich		
Reference	1864_R35_SG01		
Drawn	VL	Checked	JB
Date	29/11/2018	Rel no.	01
Drawing no.	1864_R35_SG01-18		

Title
 Reflected Solar Glare
 Frequency of Solar Reflections
 Existing Scenario
 Bare trees
 Viewpoint V3C

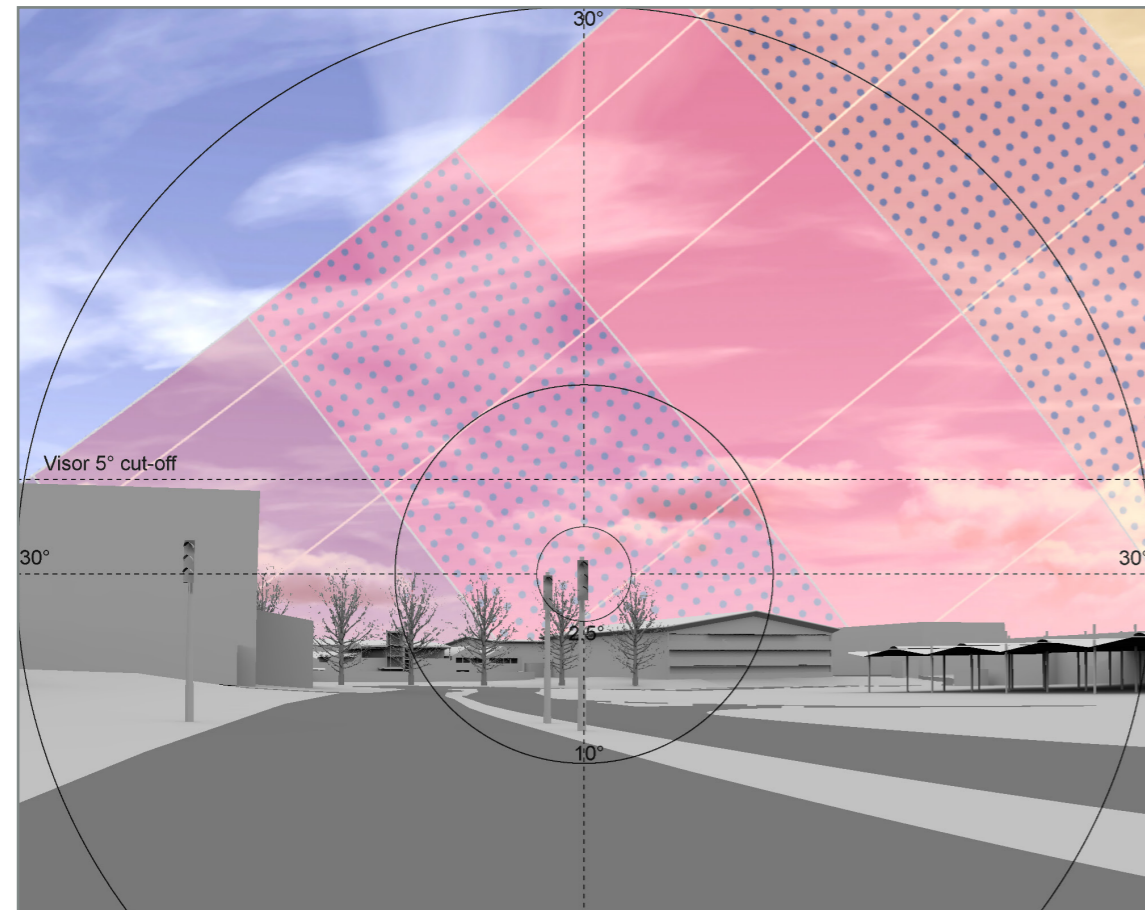

Fig. 71: Solar Glare - HOURS - Close-up

Morning	4	5	6	7	8	9	10	11	Noon	12	13	14	15	16	17	18	19	Evening	20
---------	---	---	---	---	---	---	----	----	------	----	----	----	----	----	----	----	----	---------	----

*Add one hour for British Summer Time

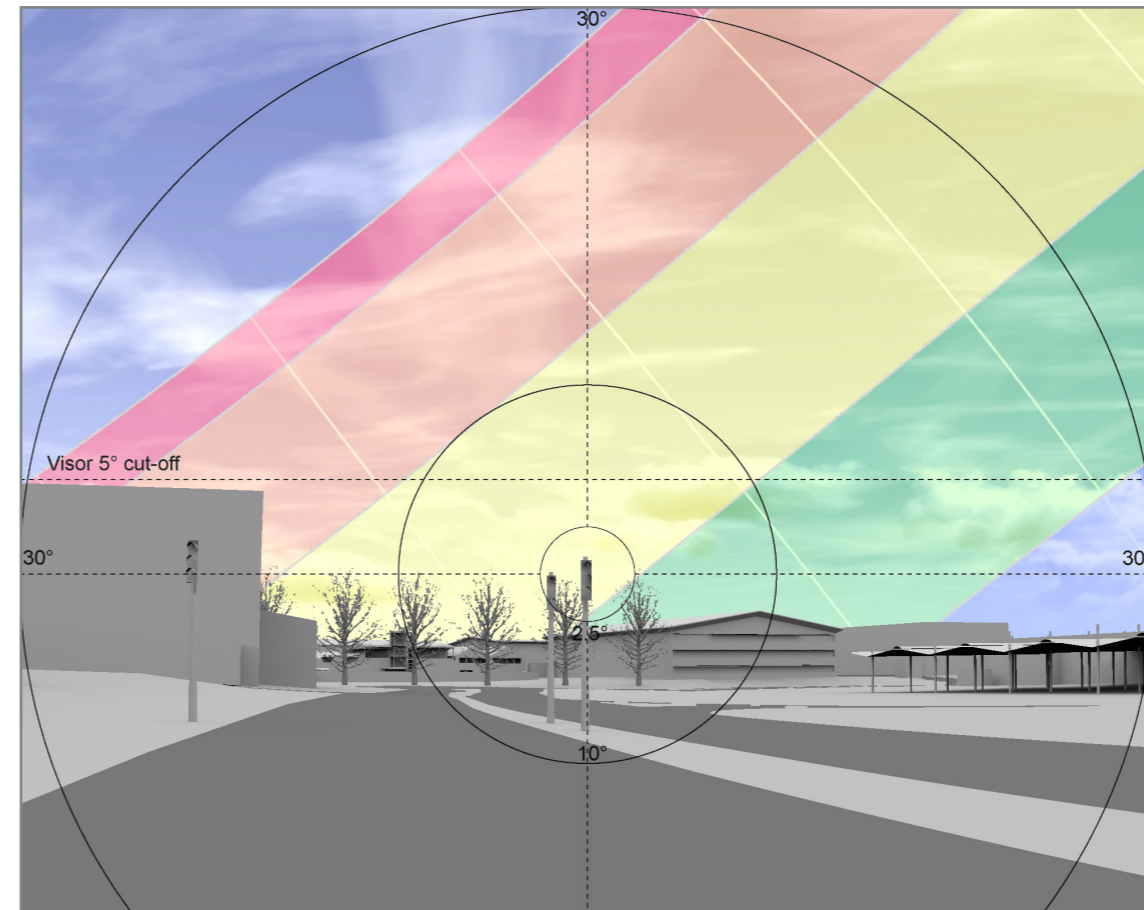

Fig. 72: Solar Glare - MONTHS - Close-up

Winter solstice	Equinoxes		Summer solstice			
21 DEC	21 JAN	21 FEB	21 MAR	21 APR	21 MAY	21 JUN
	21 NOV	21 OCT	21 SEP	21 AUG	21 JUL	

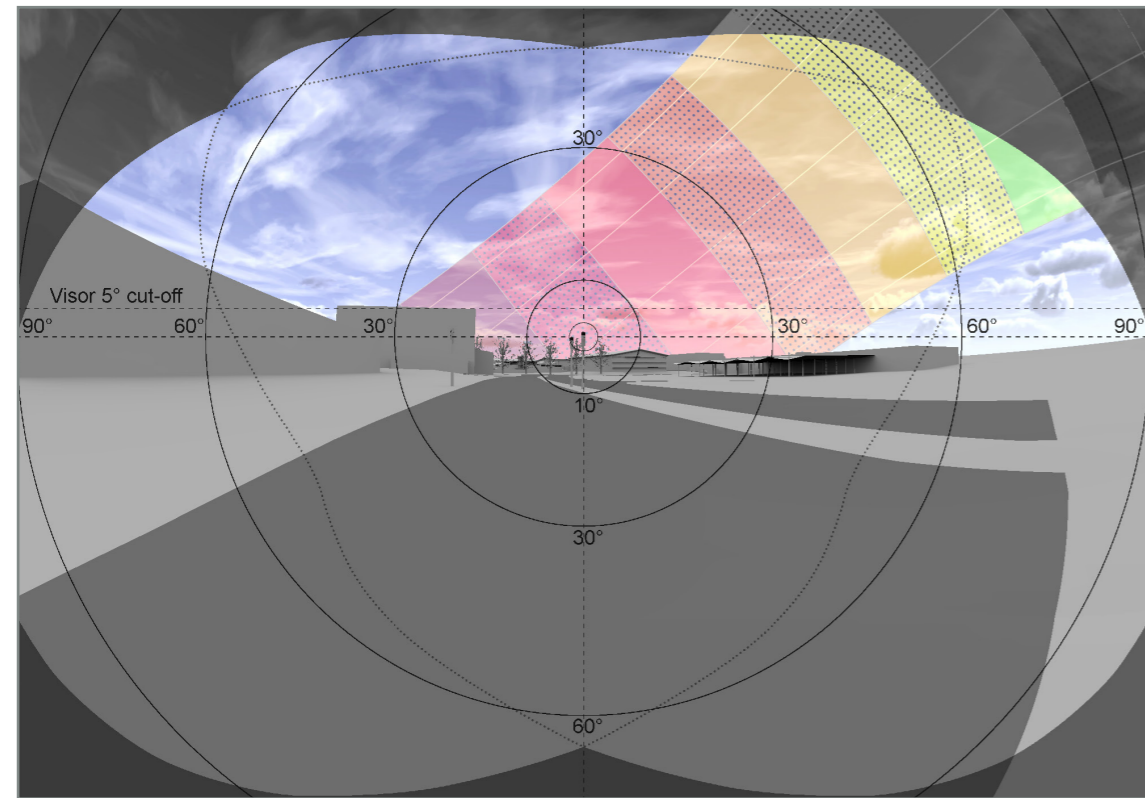

Fig. 73: Solar Glare - HOURS - 180 degrees view

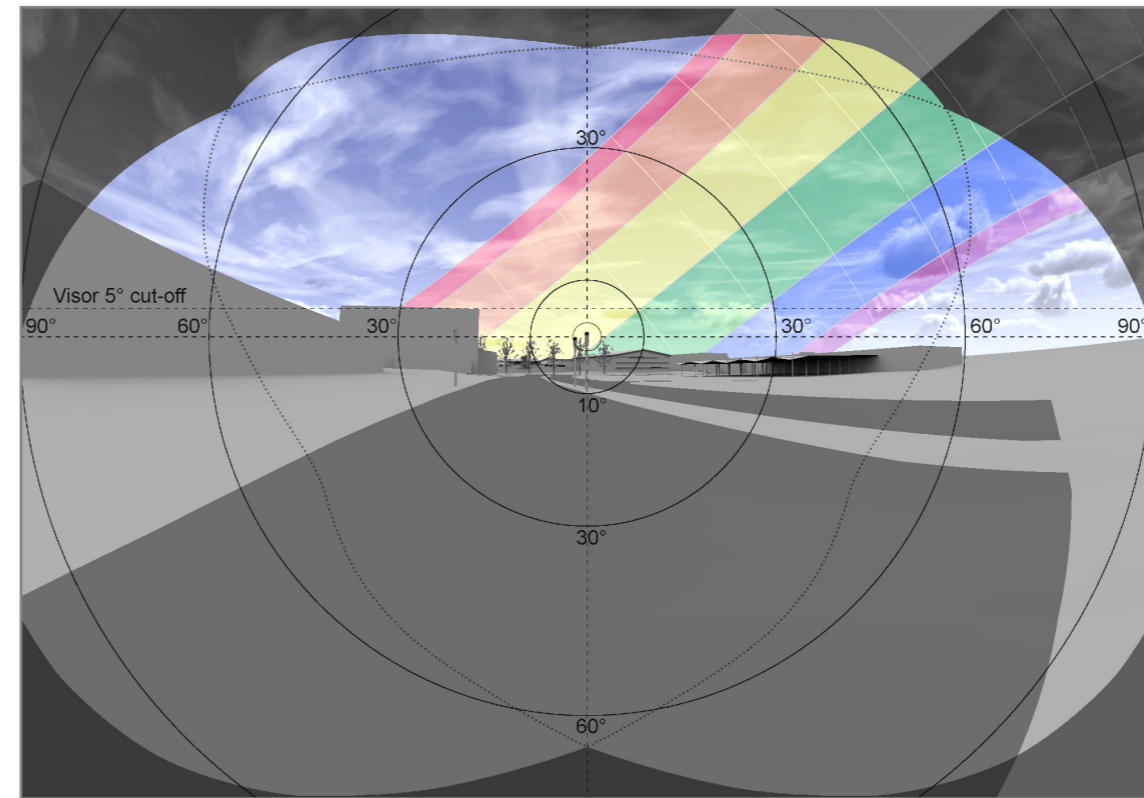

Fig. 74: Solar Glare - MONTHS - 180 degrees view

Project	Charlton Riverside Greenwich		
Reference	1864_R35_SG01		
Drawn	VL	Checked	JB
Date	29/11/2018	Rel no.	01
Drawing no.	1864_R35_SG01-19		

Title
 Reflected Solar Glare
 Frequency of Solar Reflections
 Proposed Scenario
 Bare trees
 Viewpoint V4A

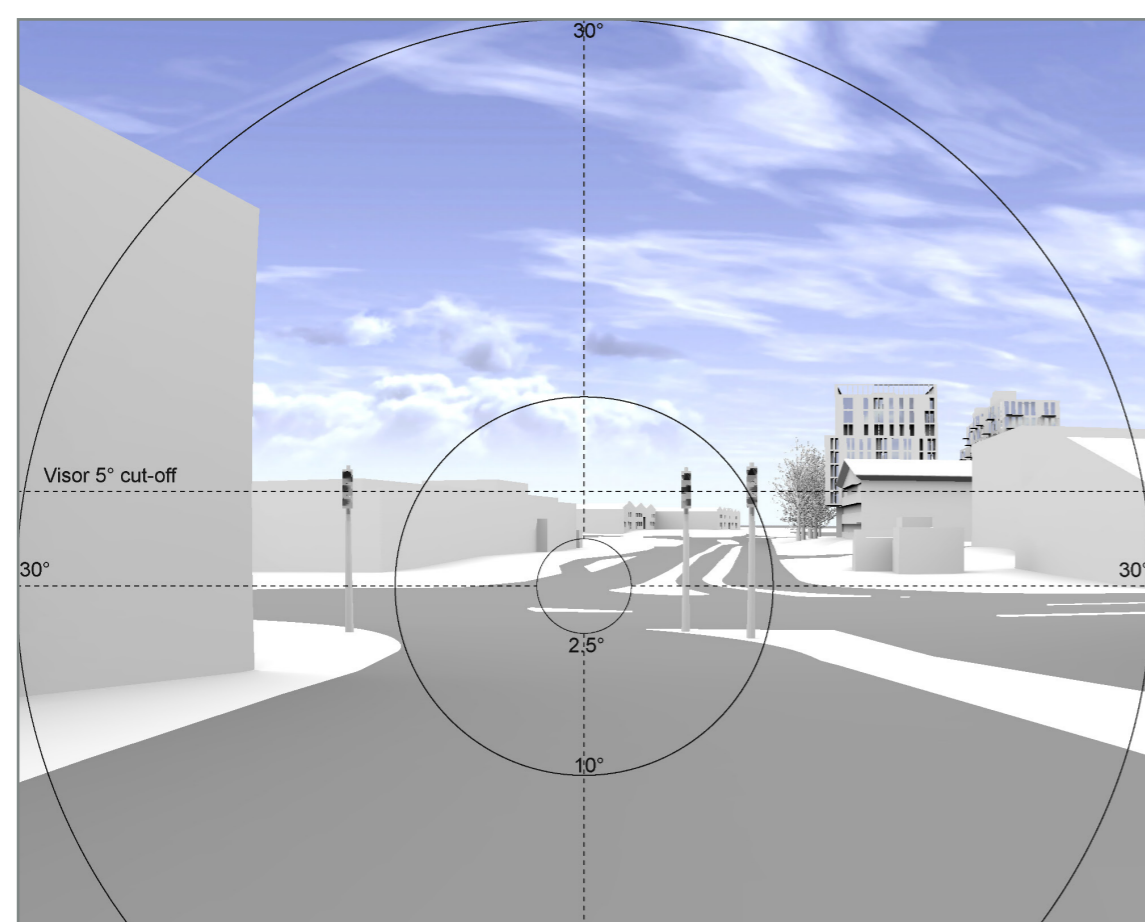

Fig. 75: Solar Glare - HOURS - Close-up

Morning	4	5	6	7	8	9	10	11	Noon	12	13	14	15	16	17	18	19	Evening	20
*Add one hour for British Summer Time																			

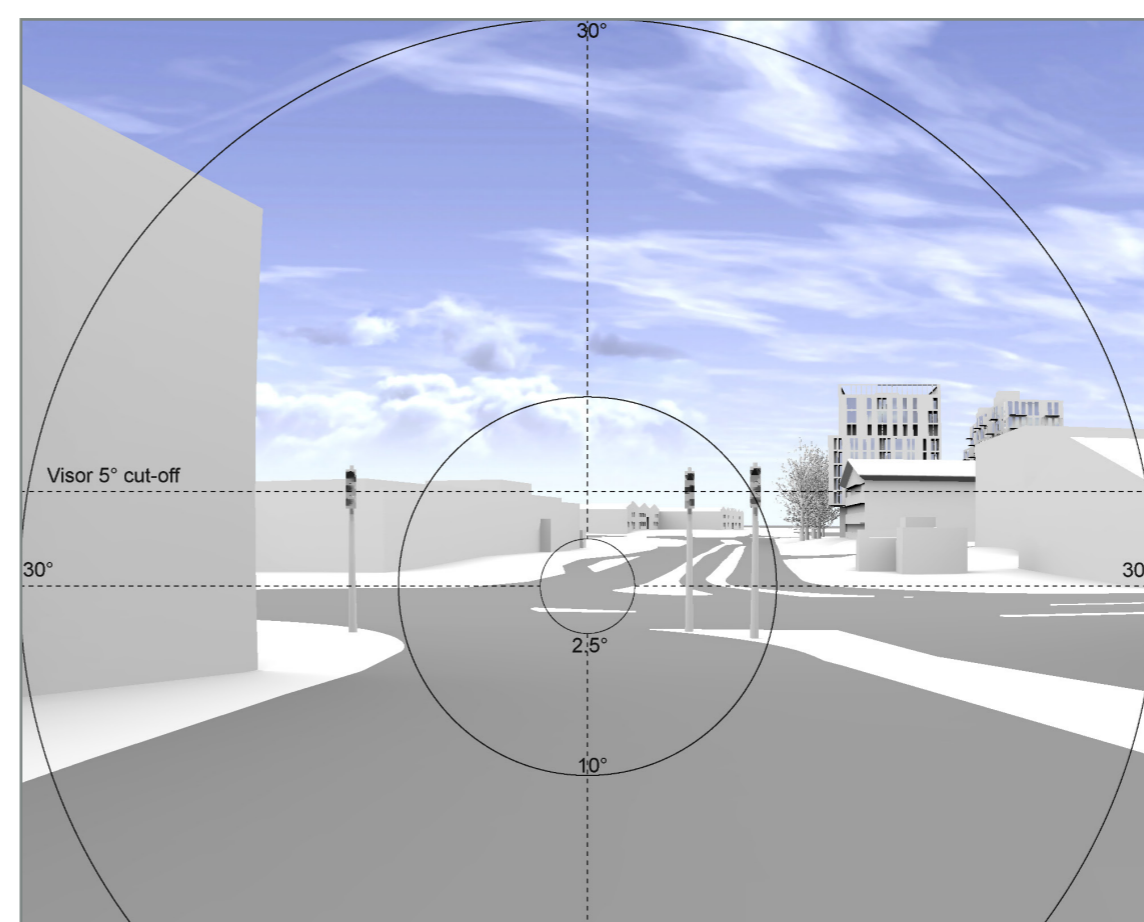

Fig. 76: Solar Glare - MONTHS - Close-up

Winter solstice	Equinoxes		Summer solstice			
21 DEC	21 JAN	21 FEB	21 MAR	21 APR	21 MAY	21 JUN
	21 NOV	21 OCT	21 SEP	21 AUG	21 JUL	

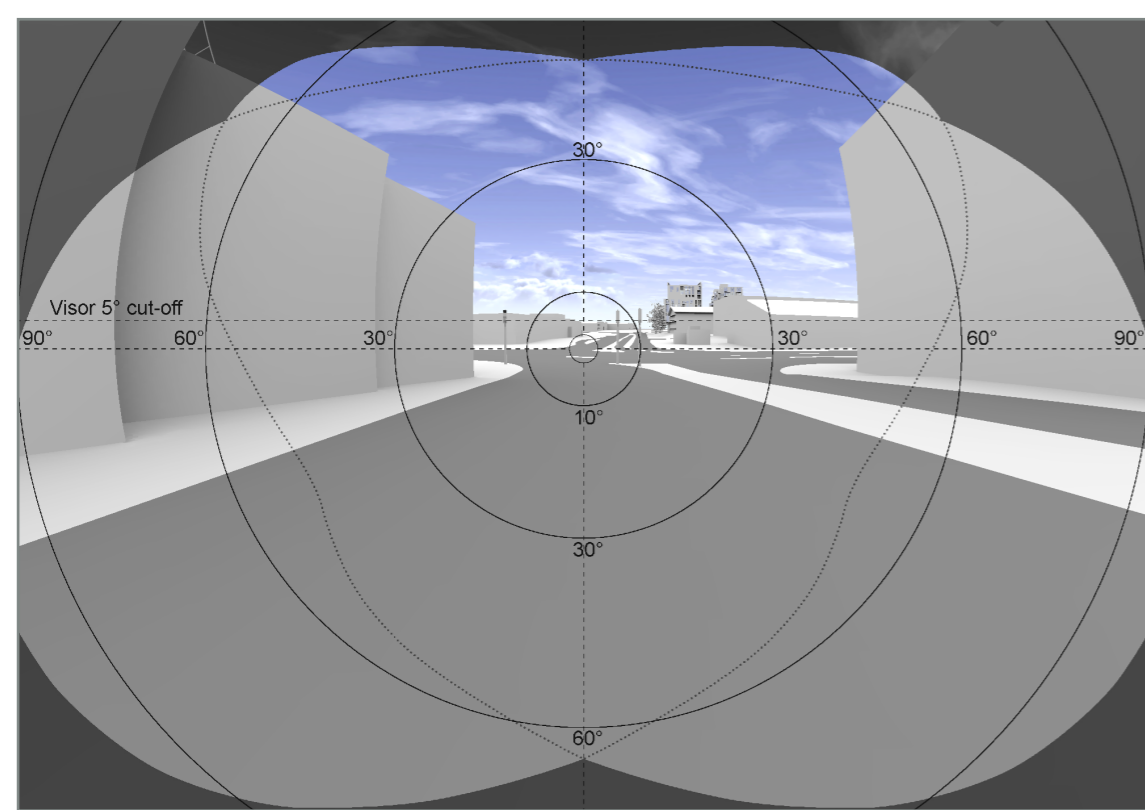

Fig. 77: Solar Glare - HOURS - 180 degrees view

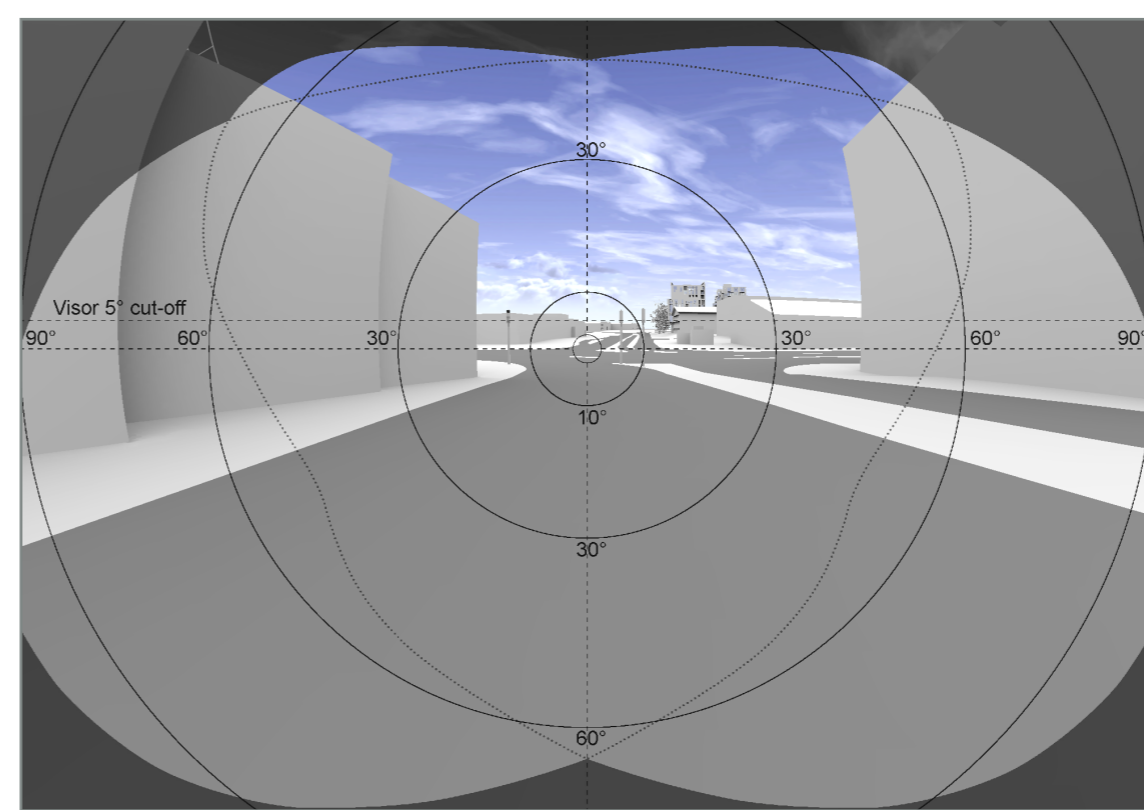

Fig. 78: Solar Glare - MONTHS - 180 degrees view

Project	Charlton Riverside Greenwich		
Reference	1864_R35_SG01		
Drawn	VL	Checked	JB
Date	29/11/2018	Rel no.	01
Drawing no.	1864_R35_SG01-20		

Title
 Reflected Solar Glare
 Frequency of Solar Reflections
 Proposed Scenario
 Trees in leaf
 Viewpoint V4A

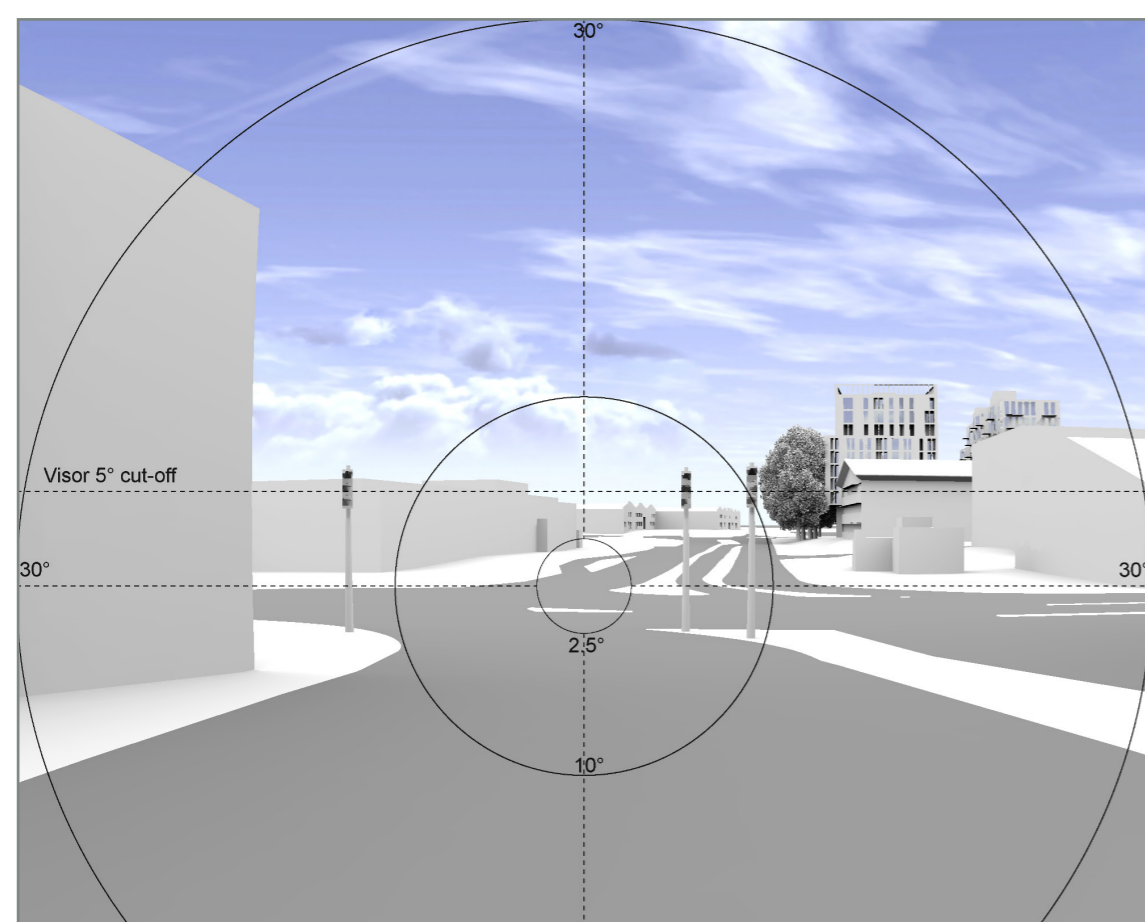

Fig. 79: Solar Glare - HOURS - Close-up

Morning	4	5	6	7	8	9	10	11	Noon	12	13	14	15	16	17	18	19	Evening	20
*Add one hour for British Summer Time																			

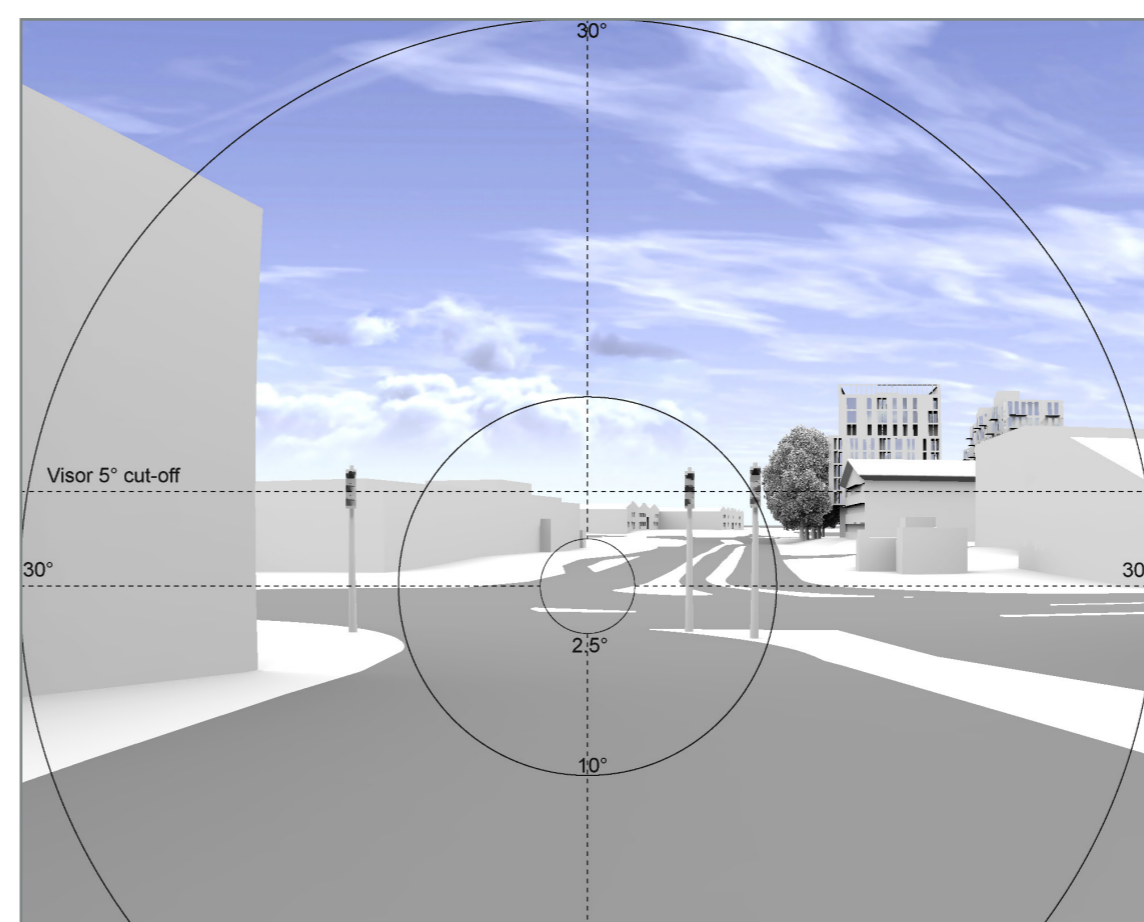

Fig. 80: Solar Glare - MONTHS - Close-up

Winter solstice	Equinoxes			Summer solstice		
21 DEC	21 JAN	21 FEB	21 MAR	21 APR	21 MAY	21 JUN
	21 NOV	21 OCT	21 SEP	21 AUG	21 JUL	

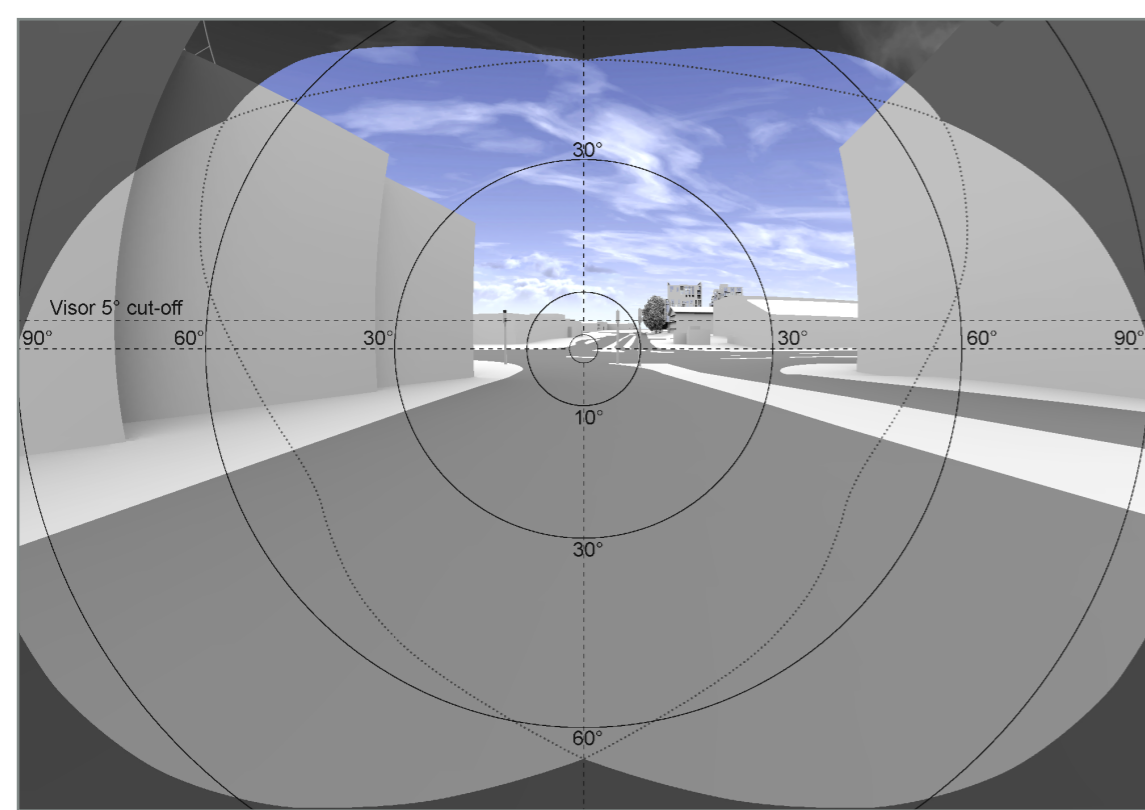

Fig. 81: Solar Glare - HOURS - 180 degrees view

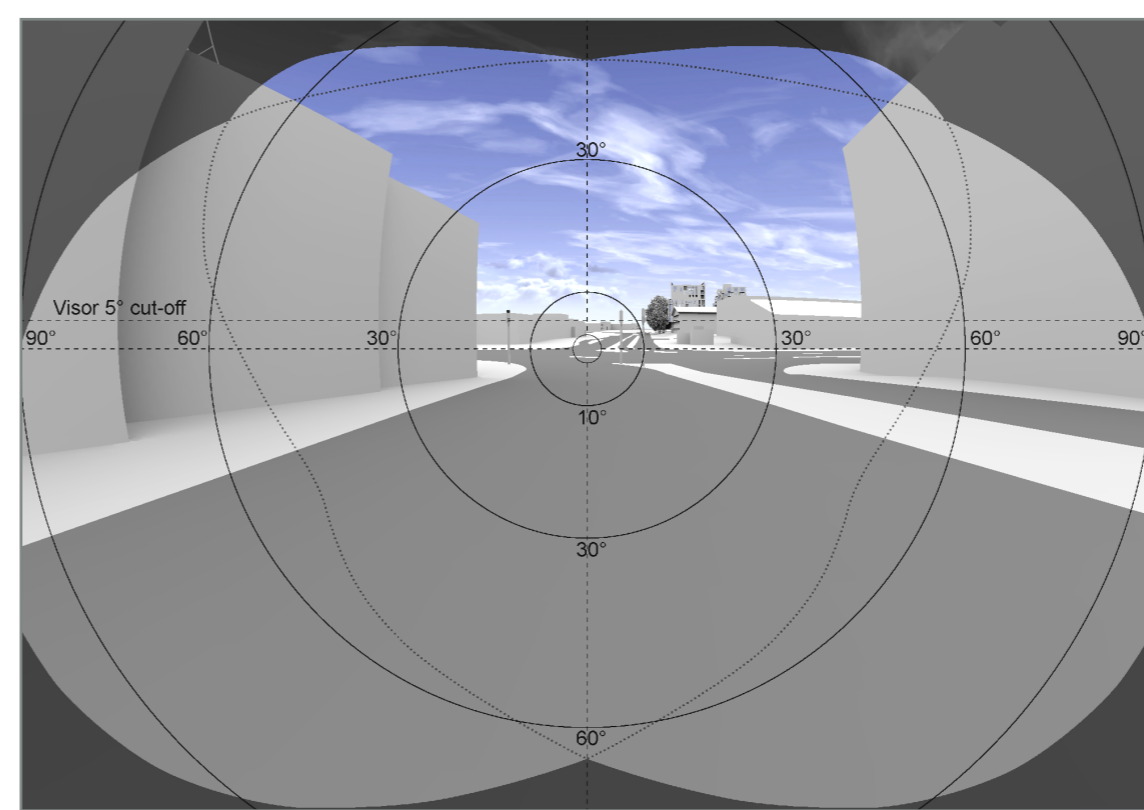

Fig. 82: Solar Glare - MONTHS - 180 degrees view

Project	Charlton Riverside Greenwich		
Reference	1864_R35_SG01		
Drawn	VL	Checked	JB
Date	29/11/2018	Rel no.	01
Drawing no.	1864_R35_SG01-21		

Title
 Reflected Solar Glare
 Frequency of Solar Reflections
 Existing Scenario
 Bare trees
 Viewpoint V4A

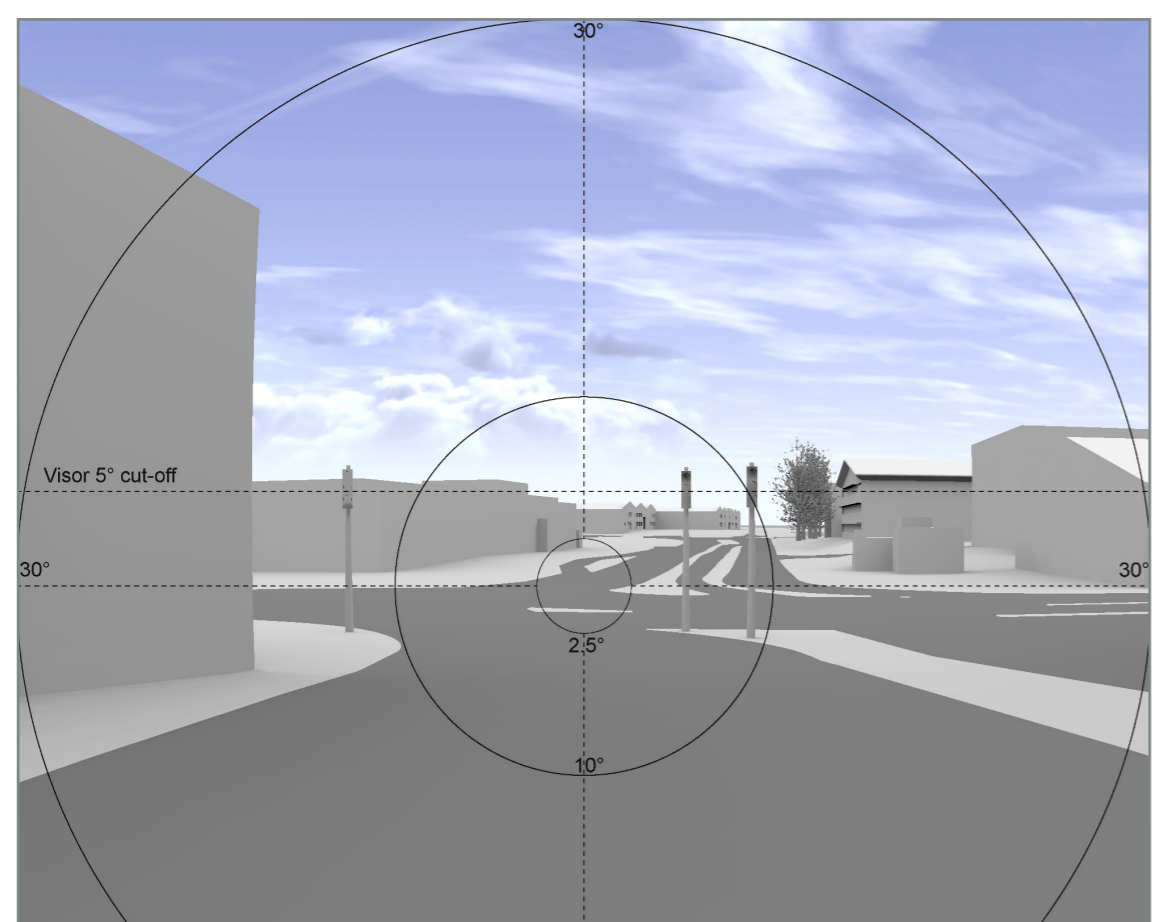

Fig. 83: Solar Glare - HOURS - Close-up

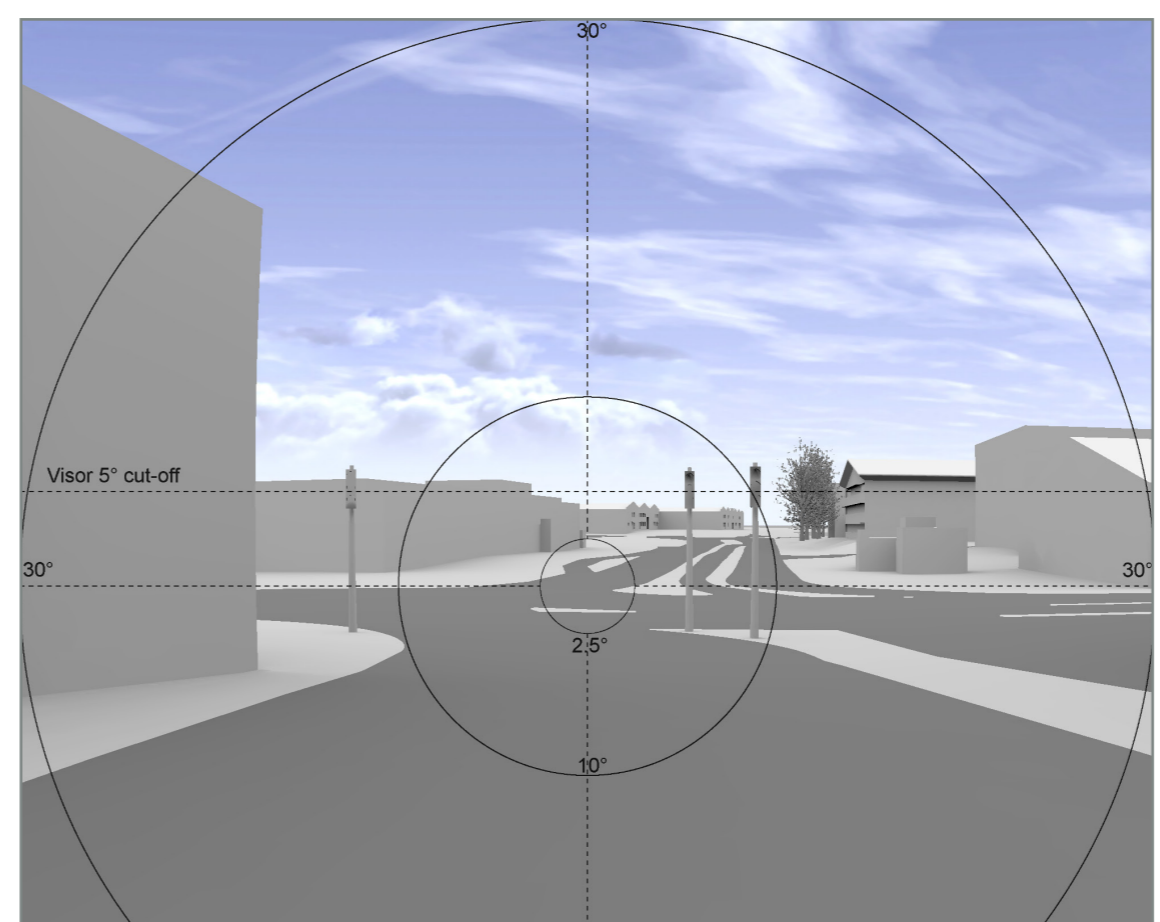
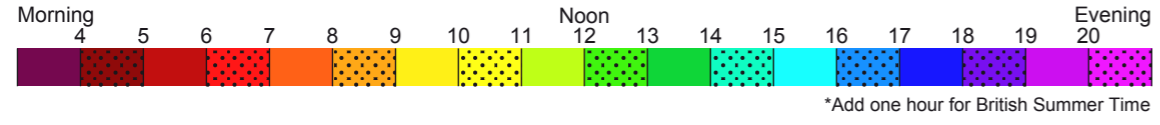

Fig. 84: Solar Glare - MONTHS - Close-up

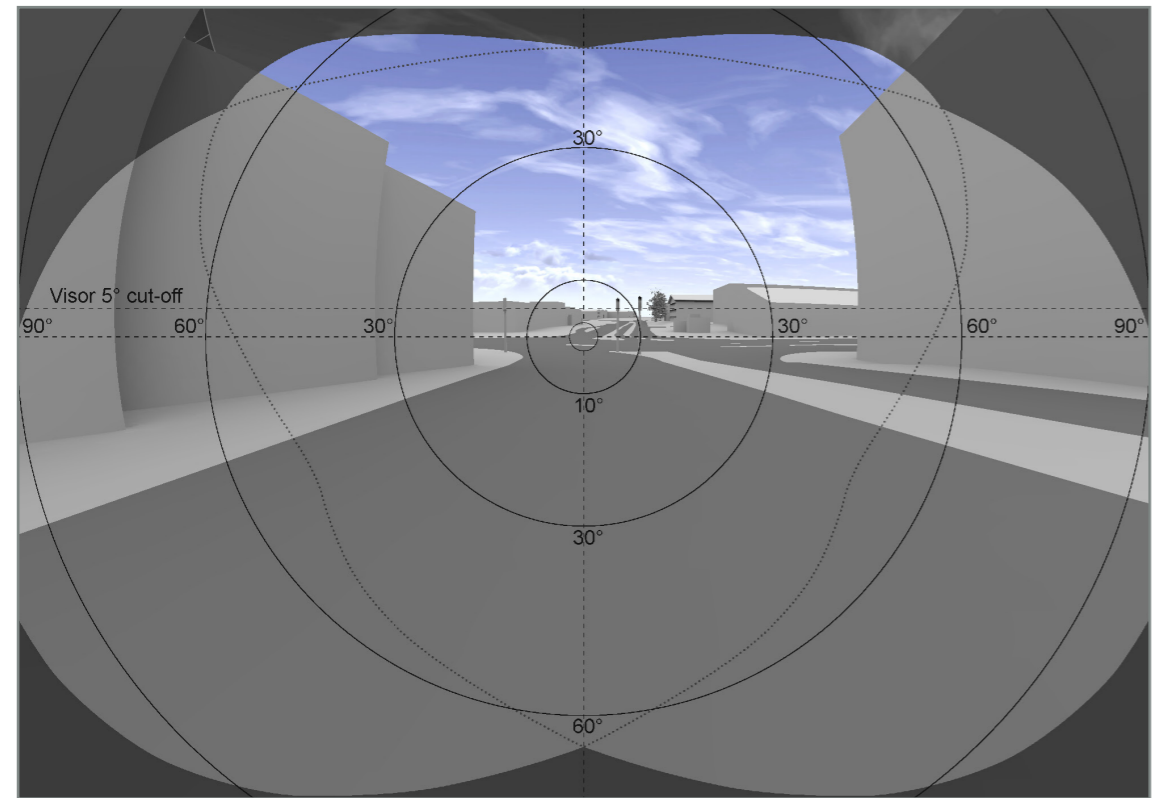
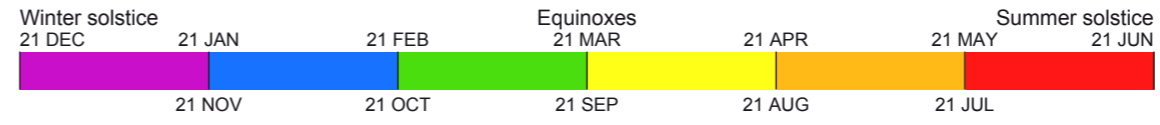

Fig. 85: Solar Glare - HOURS - 180 degrees view

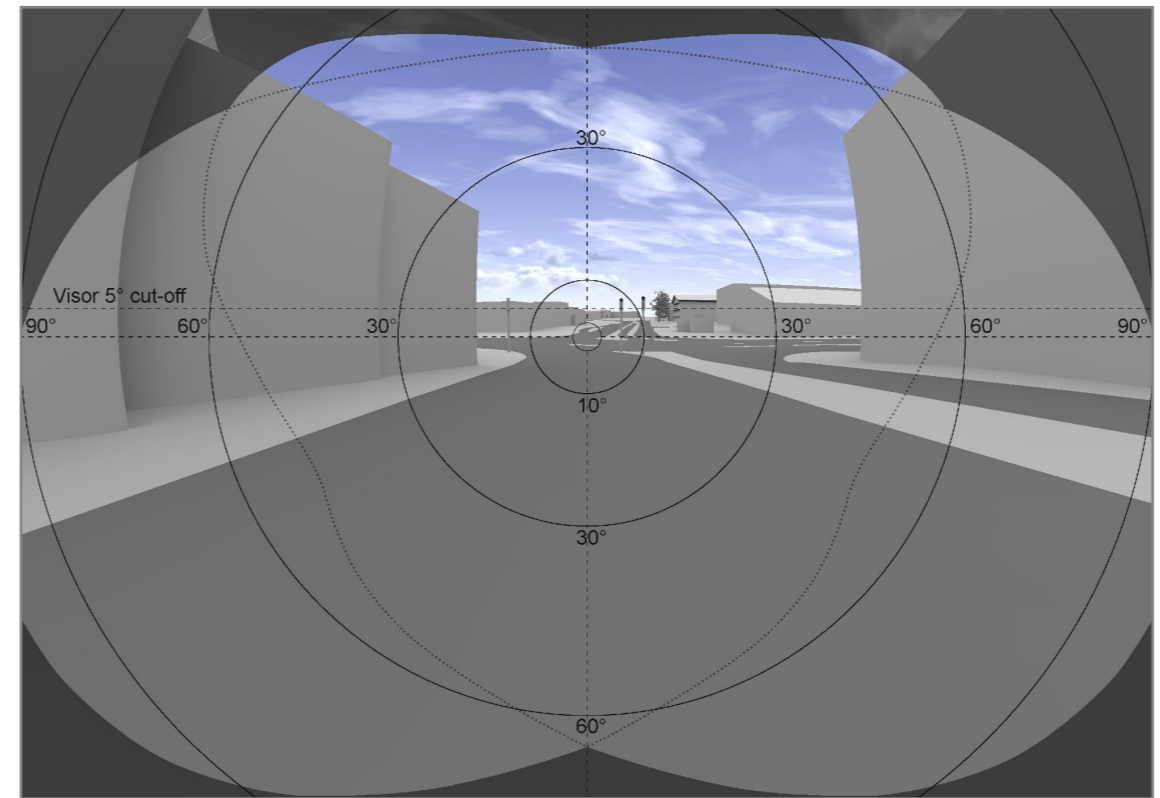

Fig. 86: Solar Glare - MONTHS - 180 degrees view

Project	Charlton Riverside Greenwich		
Reference	1864_R35_SG01		
Drawn	VL	Checked	JB
Date	29/11/2018	Rel no.	01
Drawing no.	1864_R35_SG01-22		

Title
 Reflected Solar Glare
 Frequency of Solar Reflections
 Proposed Scenario
 Bare trees
 Viewpont V4B

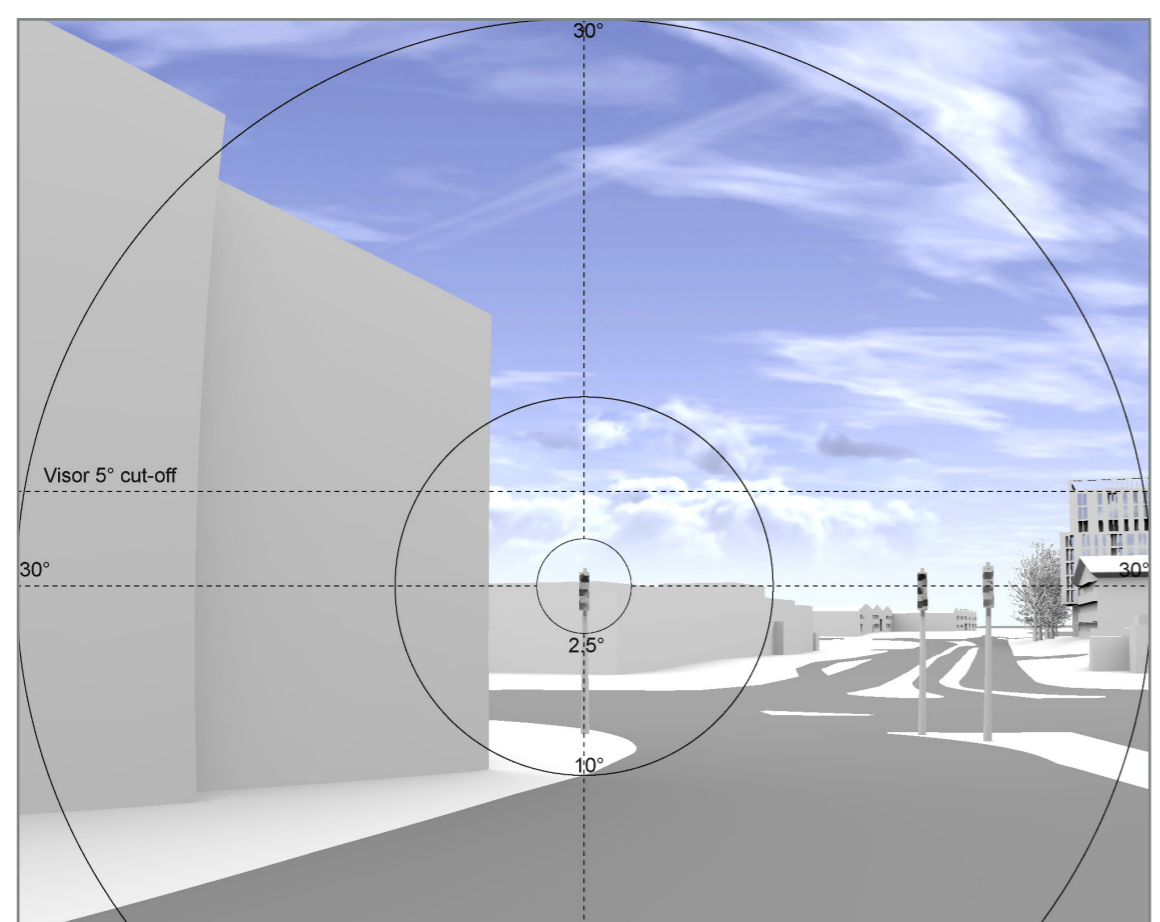

Fig. 87: Solar Glare - HOURS - Close-up

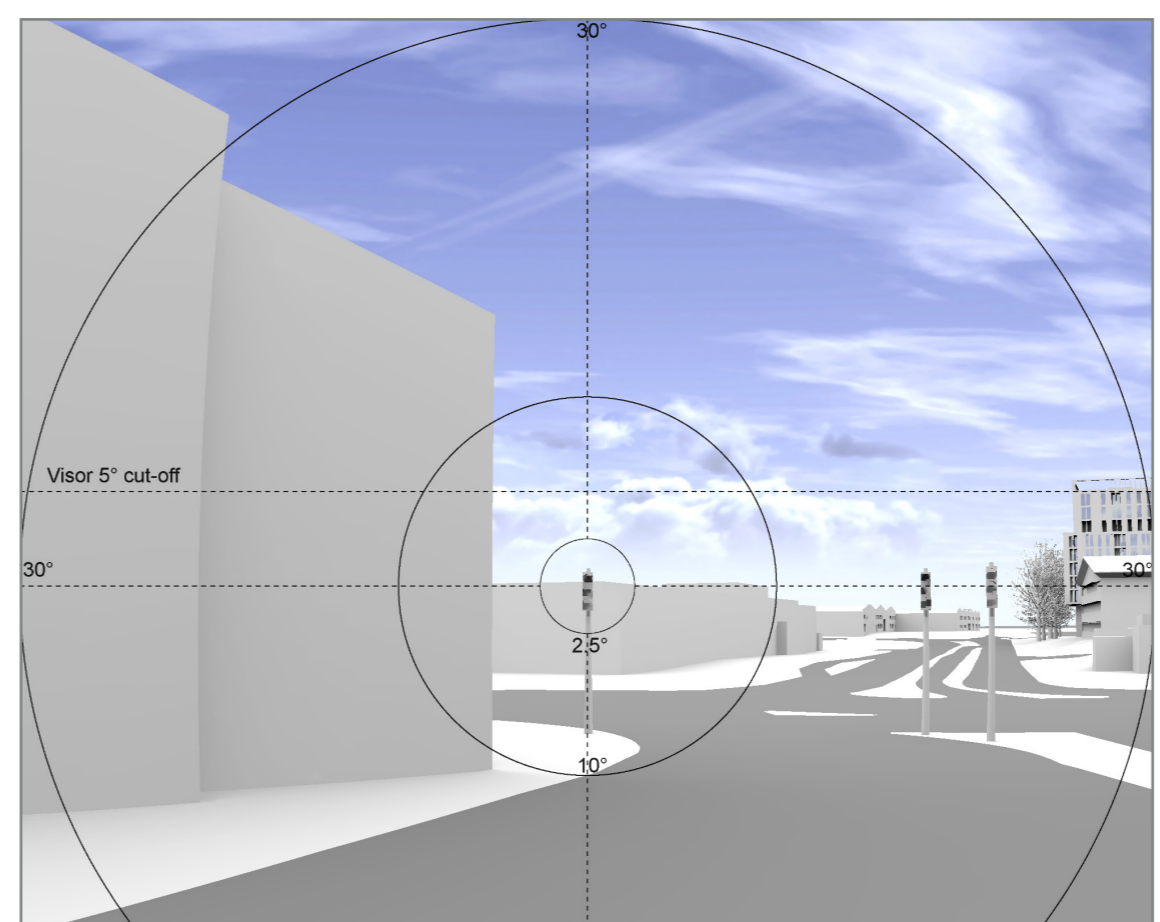
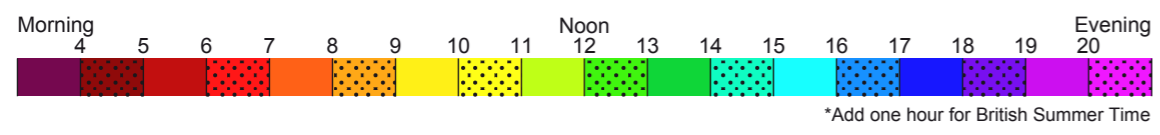

Fig. 88: Solar Glare - MONTHS - Close-up

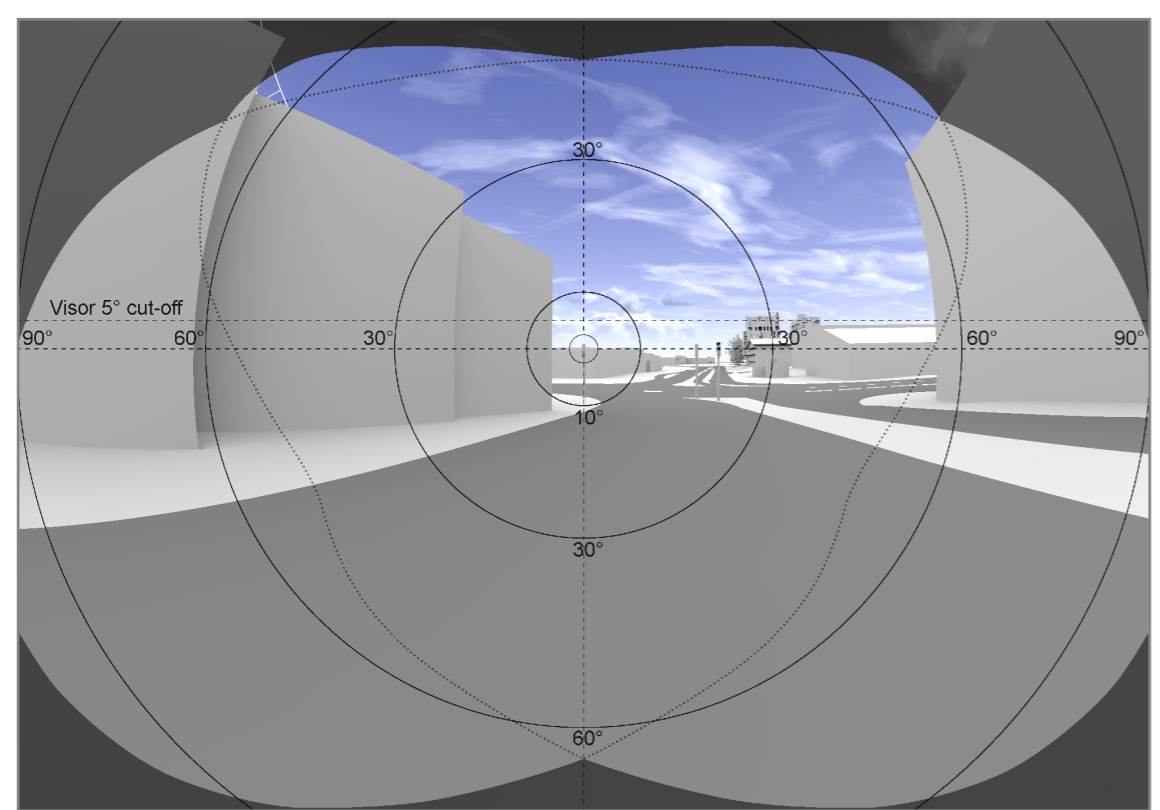
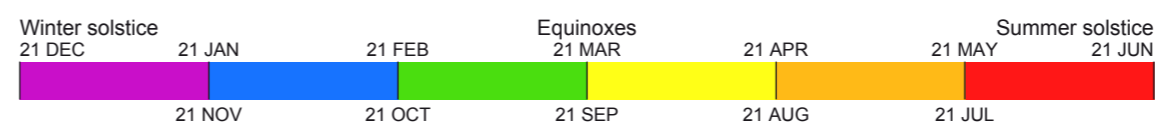

Fig. 89: Solar Glare - HOURS - 180 degrees view

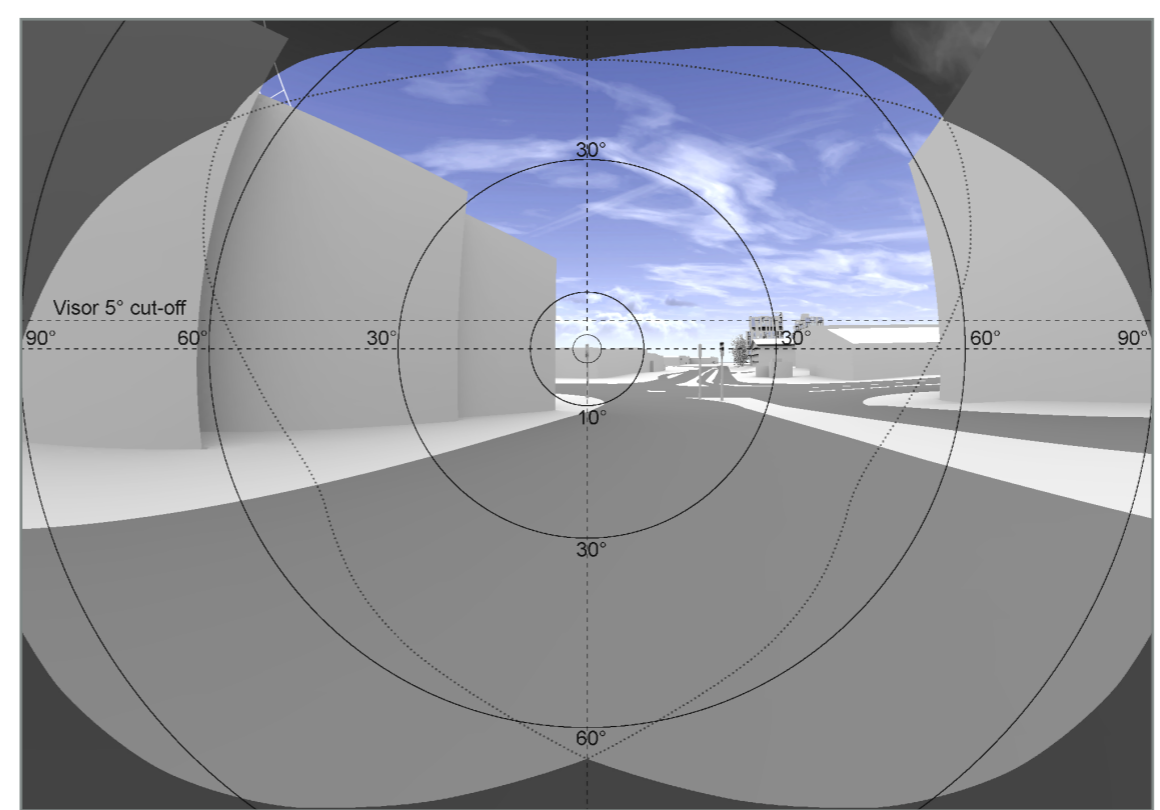

Fig. 90: Solar Glare - MONTHS - 180 degrees view

Project	Charlton Riverside Greenwich		
Reference	1864_R35_SG01		
Drawn	VL	Checked	JB
Date	29/11/2018	Rel no.	01
Drawing no.	1864_R35_SG01-23		

Title
 Reflected Solar Glare
 Frequency of Solar Reflections
 Proposed Scenario
 Trees in leaf
 Viewpoint V4B

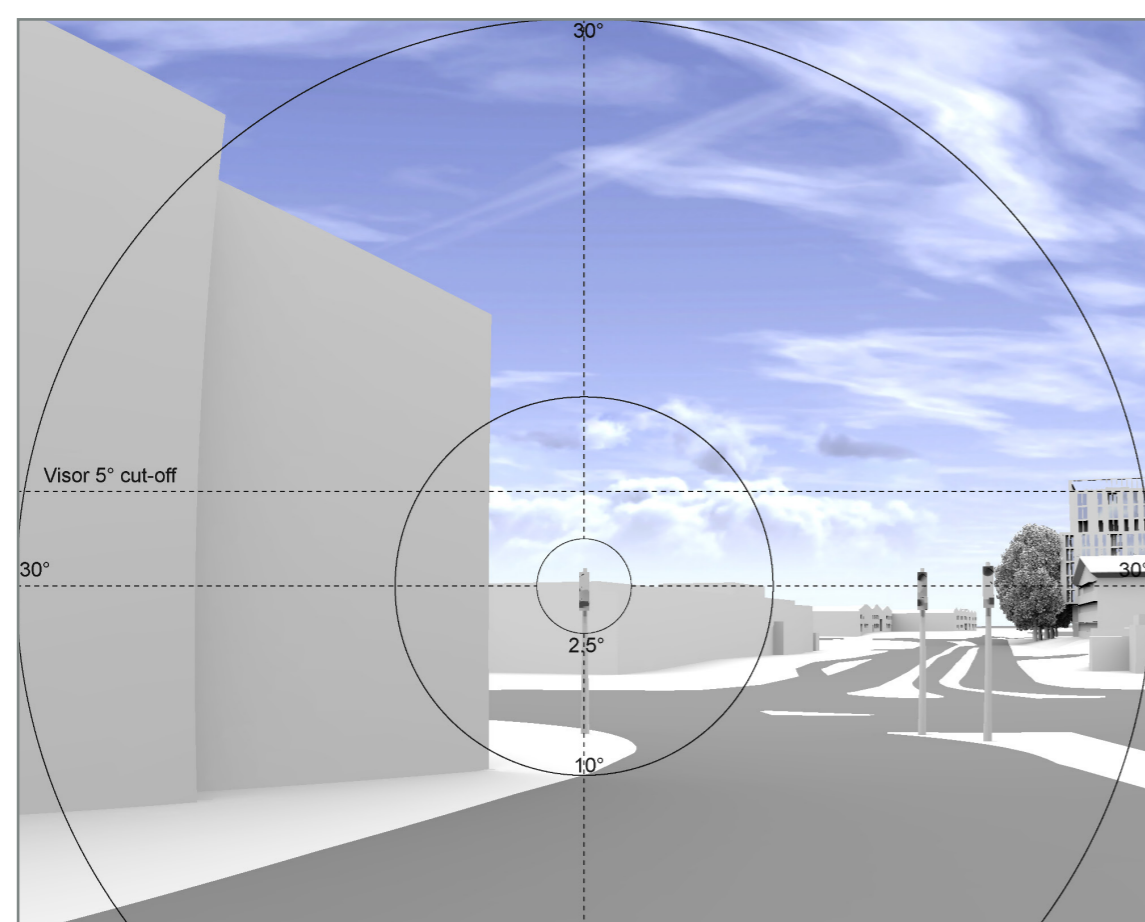

Fig. 91: Solar Glare - HOURS - Close-up

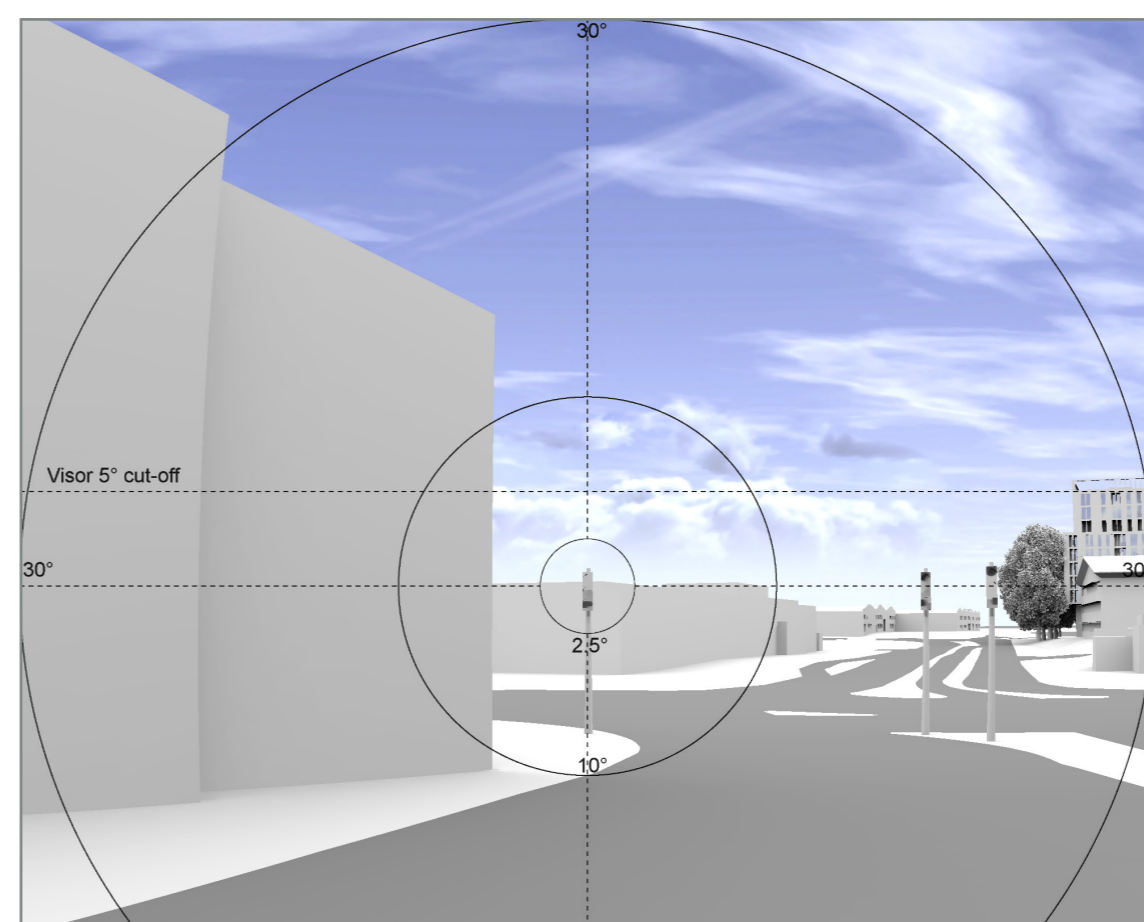
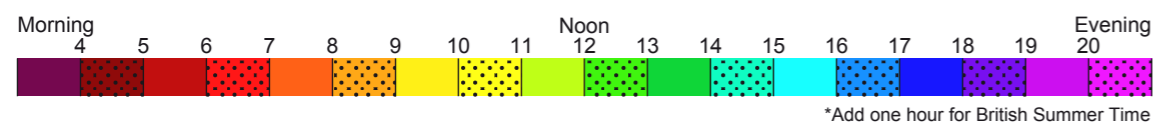

Fig. 92: Solar Glare - MONTHS - Close-up

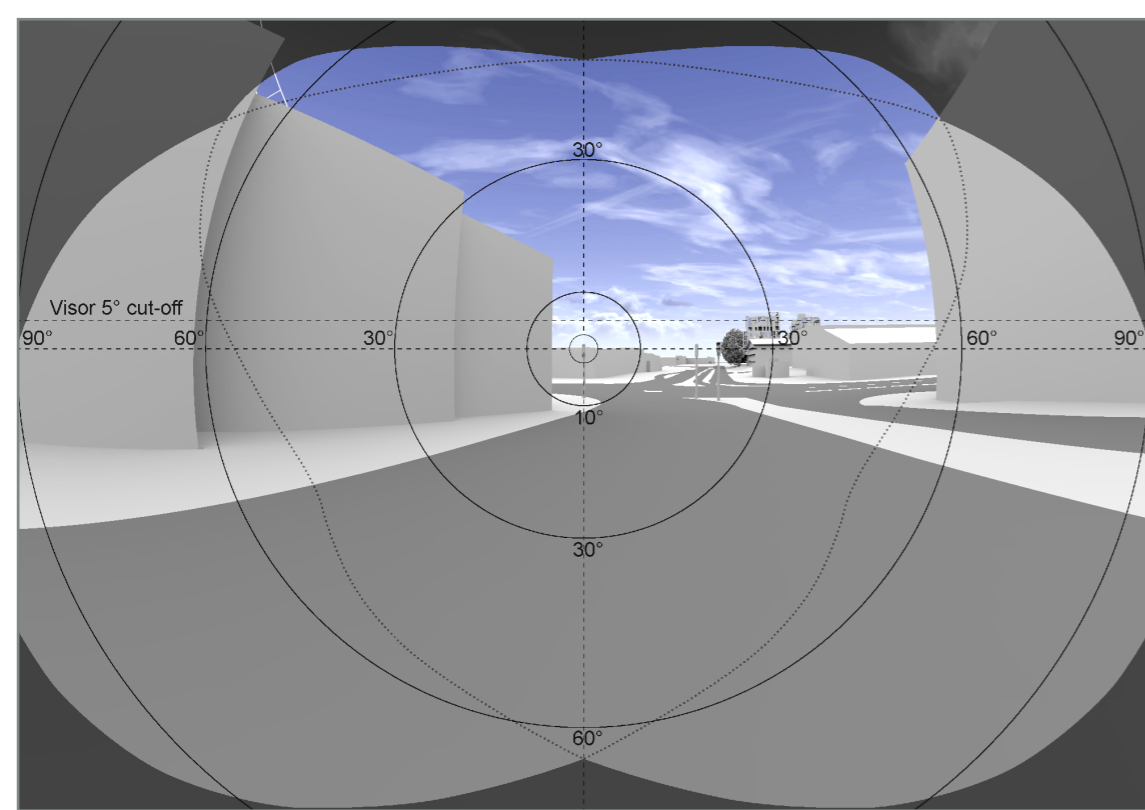
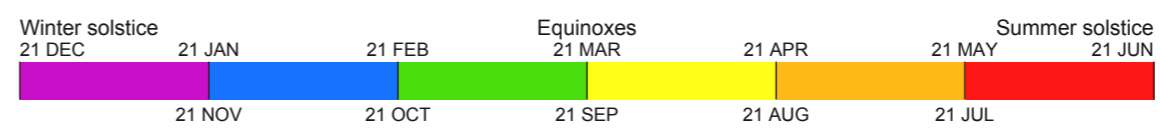

Fig. 93: Solar Glare - HOURS - 180 degrees view

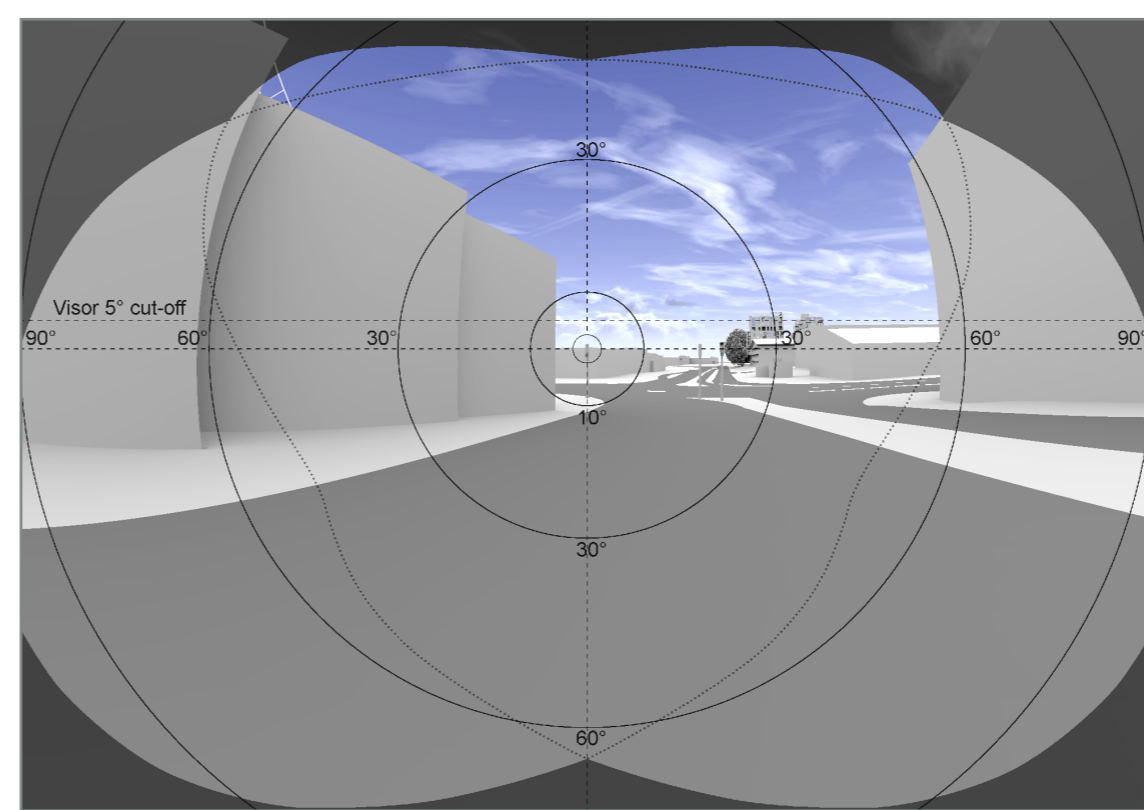

Fig. 94: Solar Glare - MONTHS - 180 degrees view

Project	Charlton Riverside Greenwich		
Reference	1864_R35_SG01		
Drawn	VL	Checked	JB
Date	29/11/2018	Rel no.	01
Drawing no.	1864_R35_SG01-24		

Title
 Reflected Solar Glare
 Frequency of Solar Reflections
 Existing Scenario
 Bare trees
 Viewpoint V4B

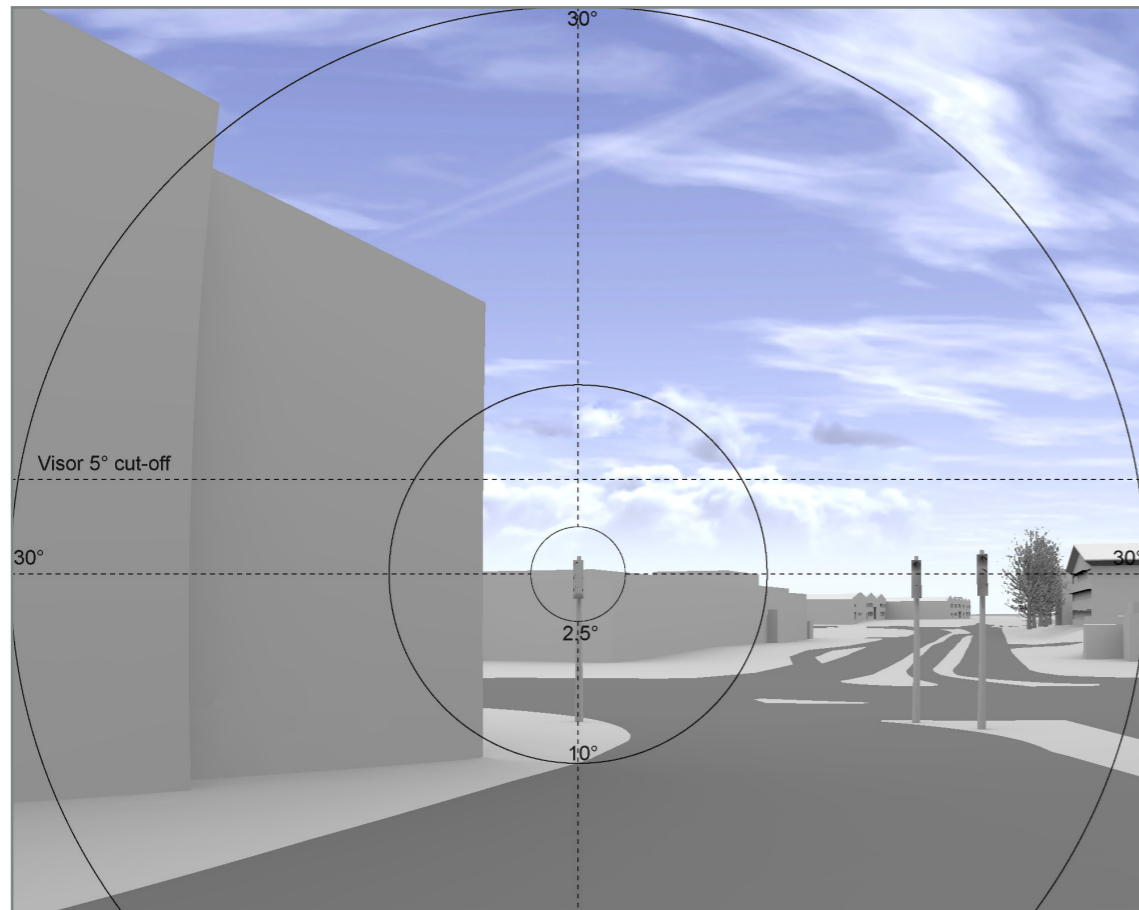

Fig. 95: Solar Glare - HOURS - Close-up

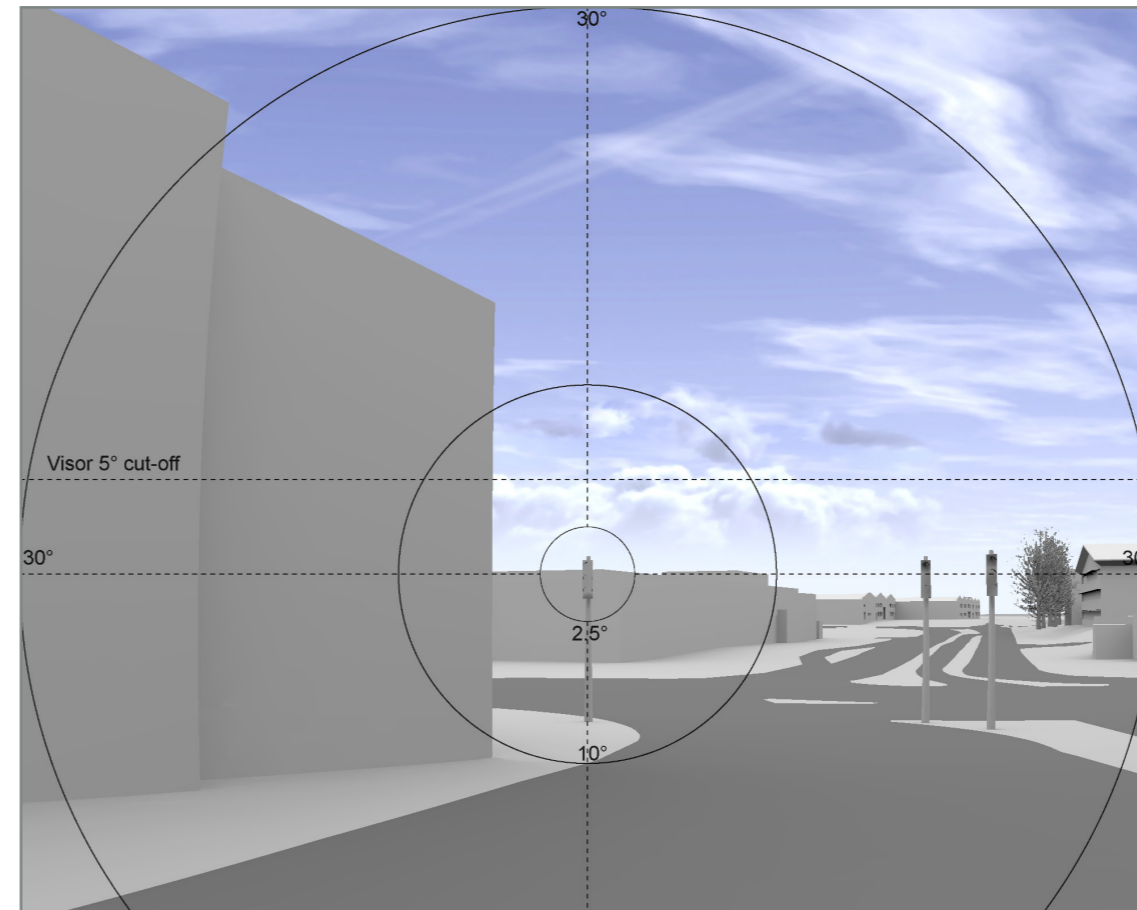
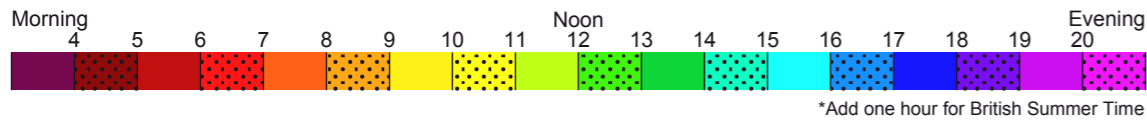

Fig. 96: Solar Glare - MONTHS - Close-up

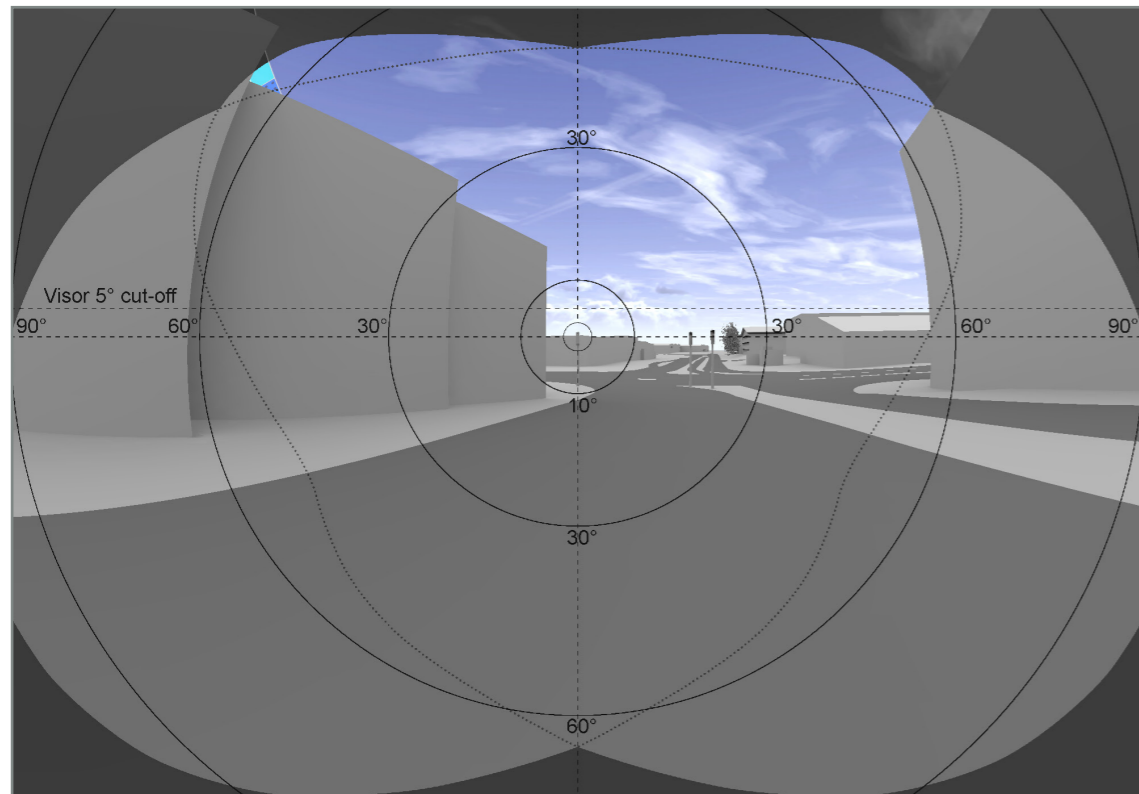
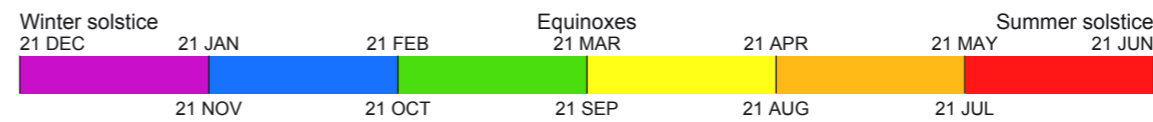

Fig. 97: Solar Glare - HOURS - 180 degrees view

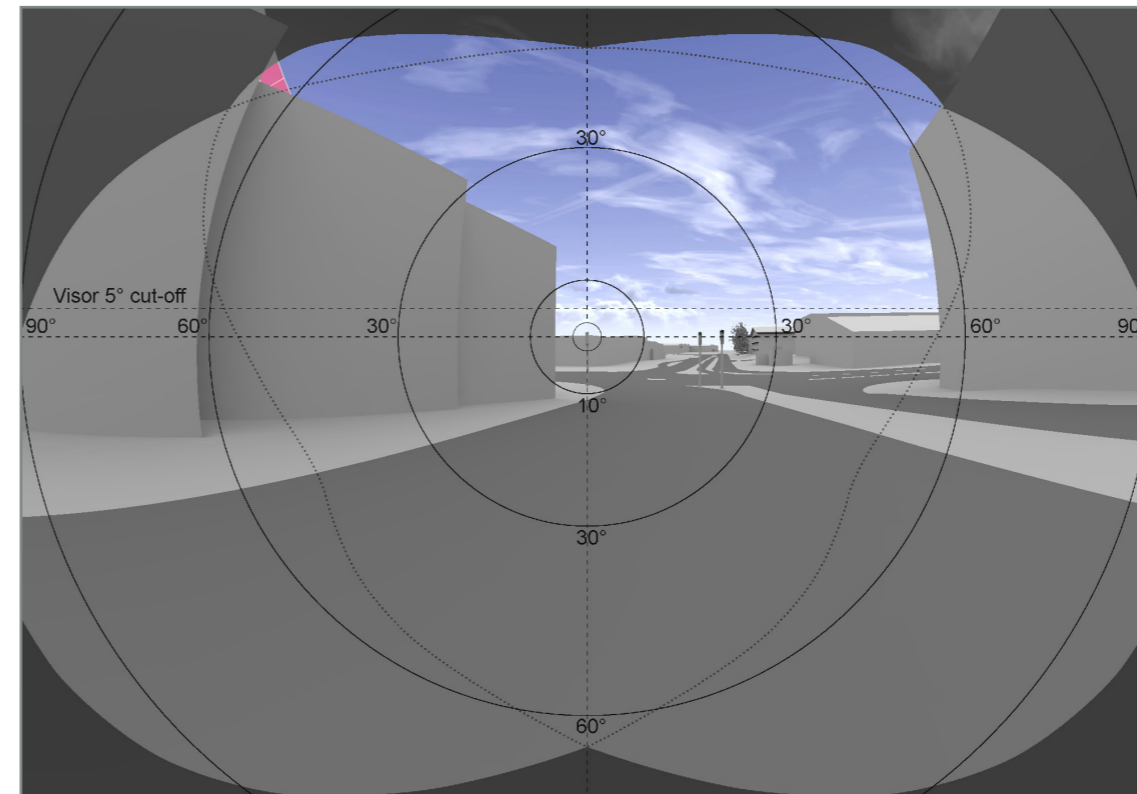

Fig. 98: Solar Glare - MONTHS - 180 degrees view

Title
 Reflected Solar Glare
 Frequency of Solar Reflections
 Proposed Scenario
 Bare trees
 Viewpont V4C

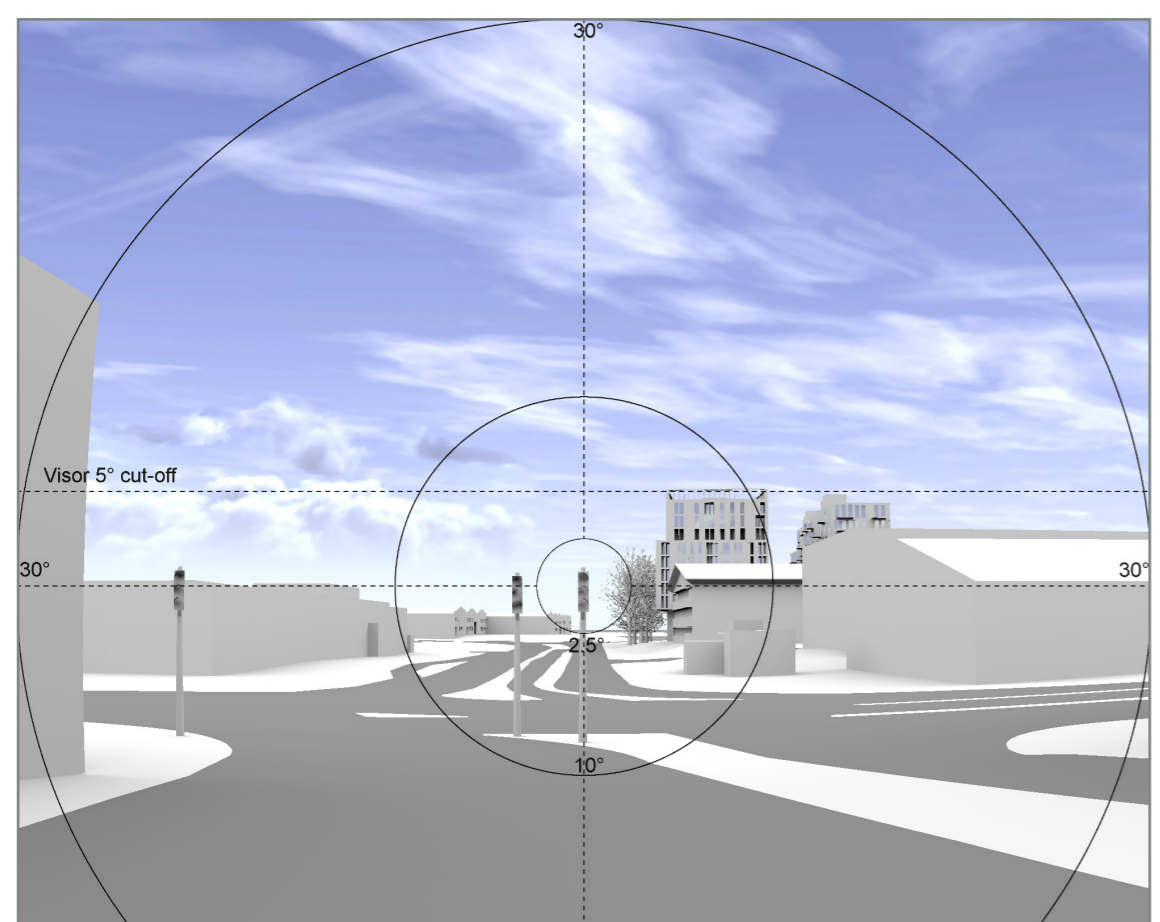

Fig. 99: Solar Glare - HOURS - Close-up

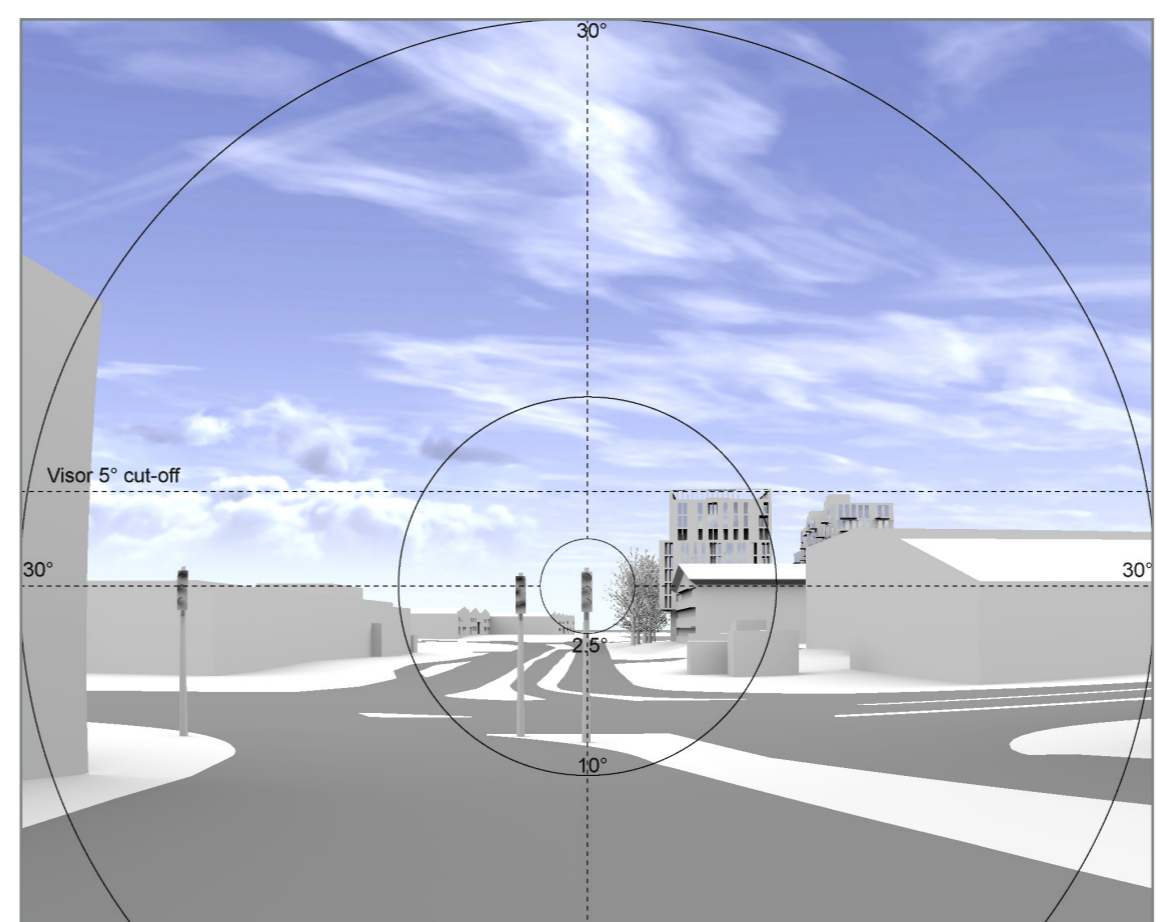
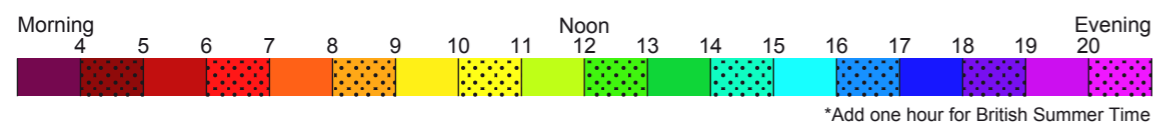

Fig. 100: Solar Glare - MONTHS - Close-up

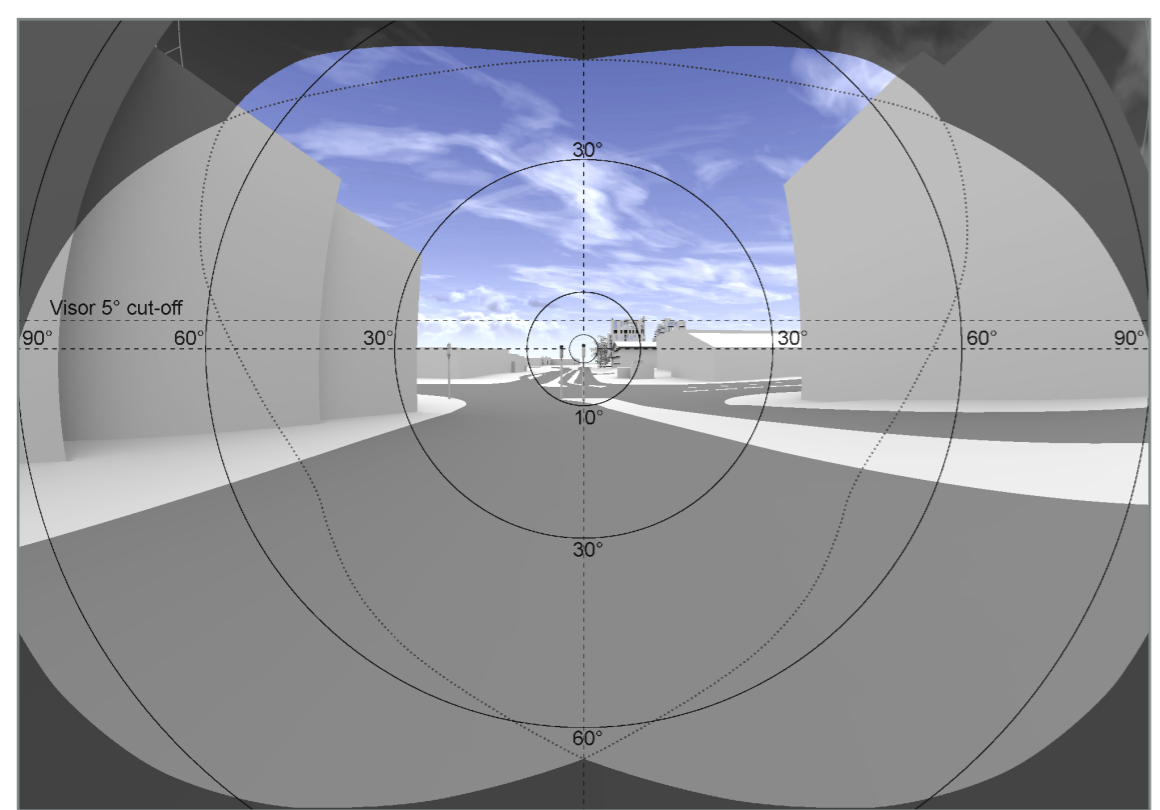
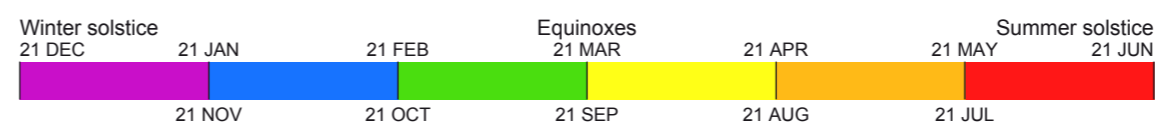

Fig. 101: Solar Glare - HOURS - 180 degrees view

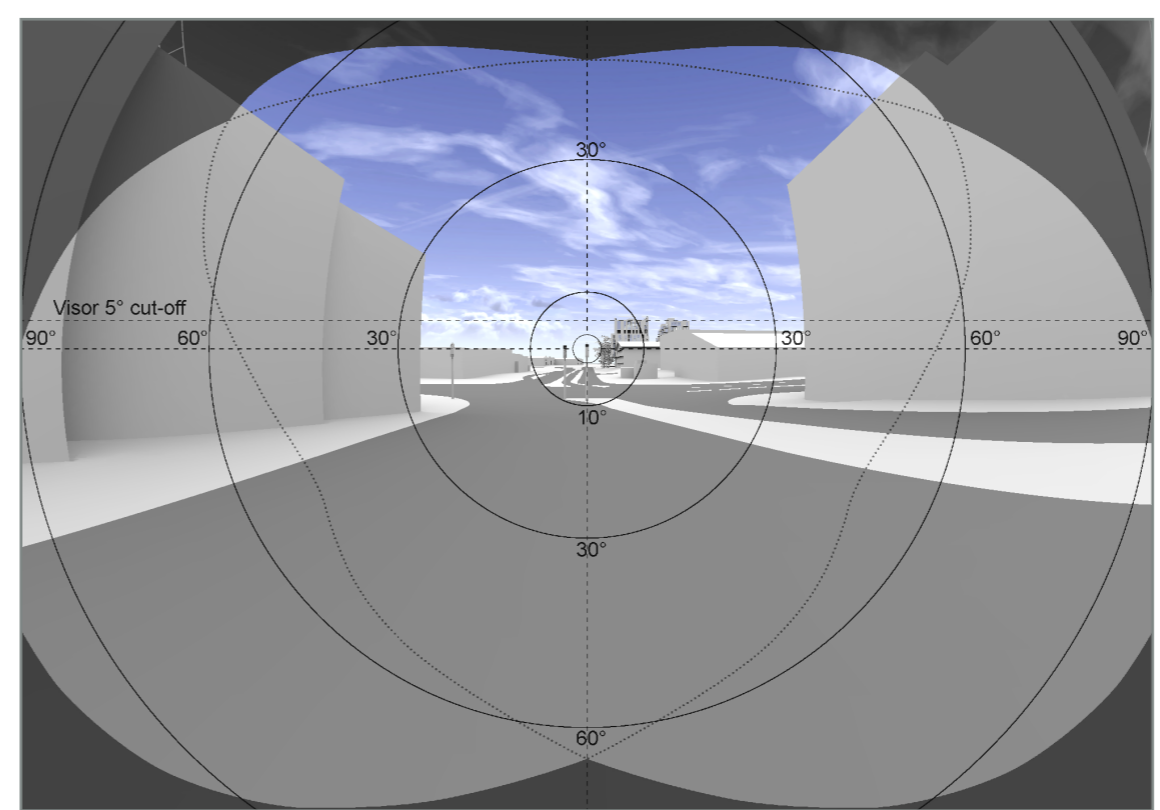

Fig. 102: Solar Glare - MONTHS - 180 degrees view

Project	Charlton Riverside Greenwich		
Reference	1864_R35_SG01		
Drawn	VL	Checked	JB
Date	29/11/2018	Rel no.	01
Drawing no.	1864_R35_SG01-26		

Title
 Reflected Solar Glare
 Frequency of Solar Reflections
 Proposed Scenario
 Trees in leaf
 Viewpoint V4C

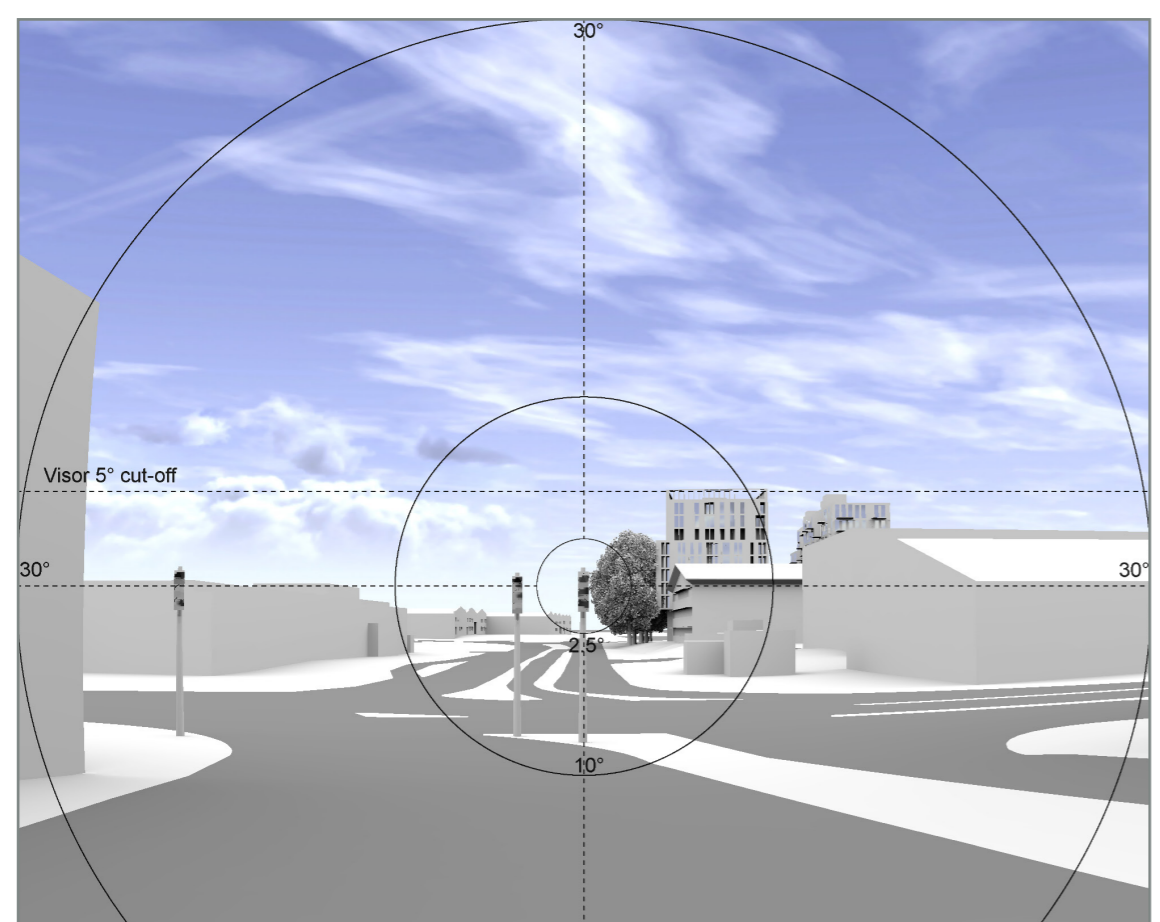

Fig. 103: Solar Glare - HOURS - Close-up

Morning	4	5	6	7	8	9	10	11	Noon	12	13	14	15	16	17	18	19	Evening	20
*Add one hour for British Summer Time																			

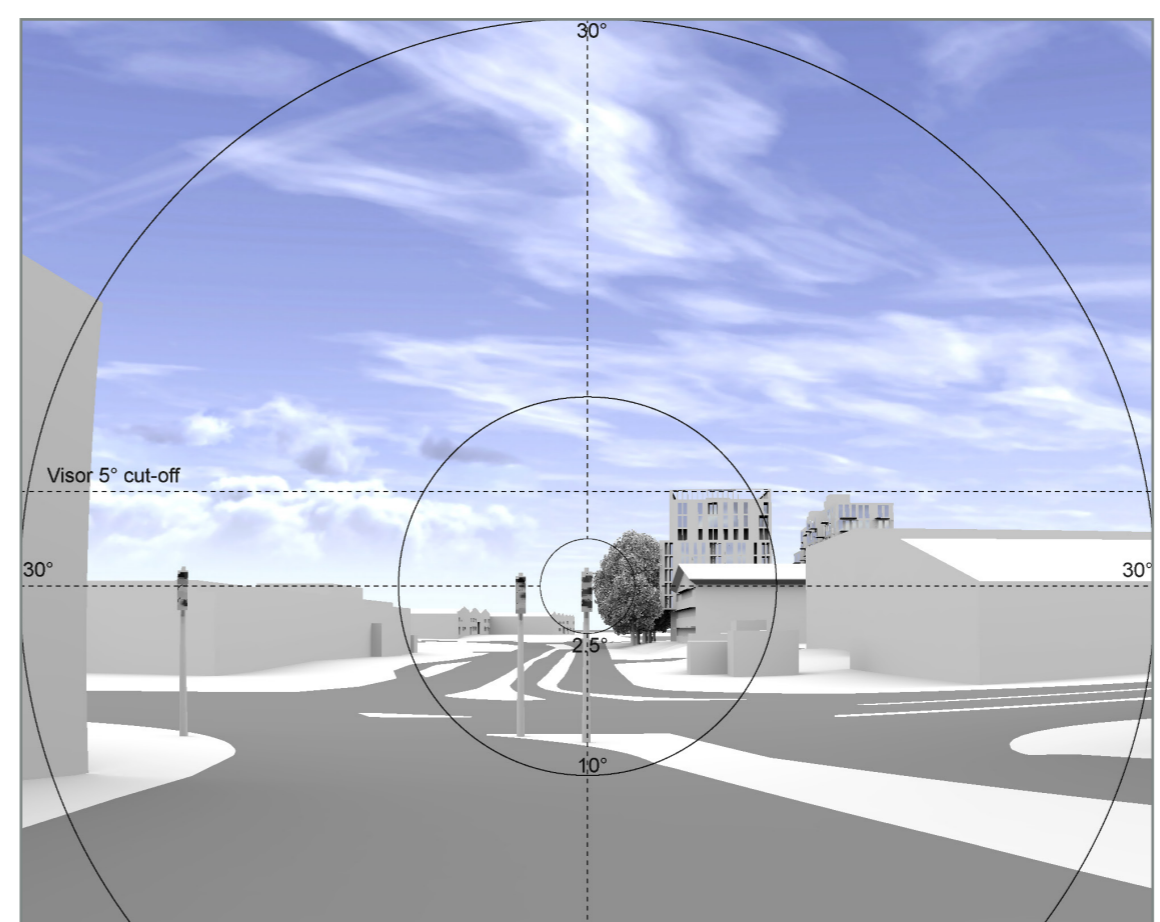

Fig. 104: Solar Glare - MONTHS - Close-up

Winter solstice	Equinoxes		Summer solstice			
21 DEC	21 JAN	21 FEB	21 MAR	21 APR	21 MAY	21 JUN
	21 NOV	21 OCT	21 SEP	21 AUG	21 JUL	

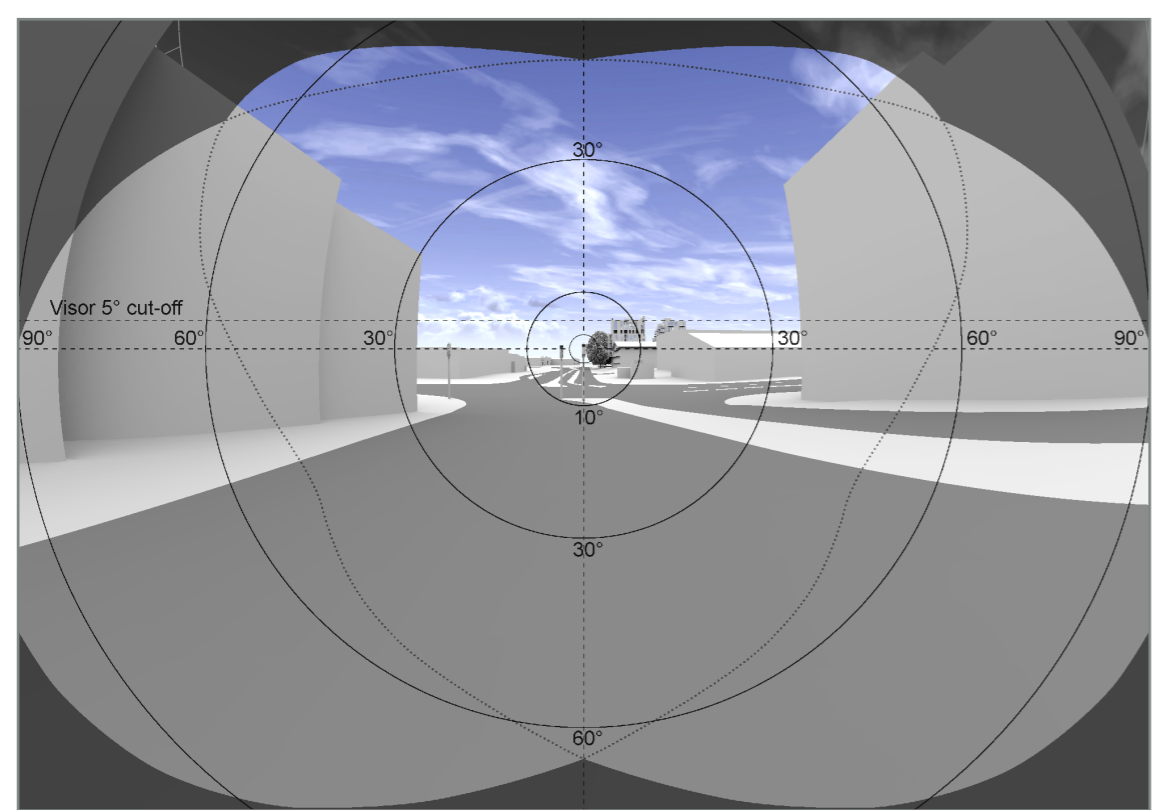

Fig. 105: Solar Glare - HOURS - 180 degrees view

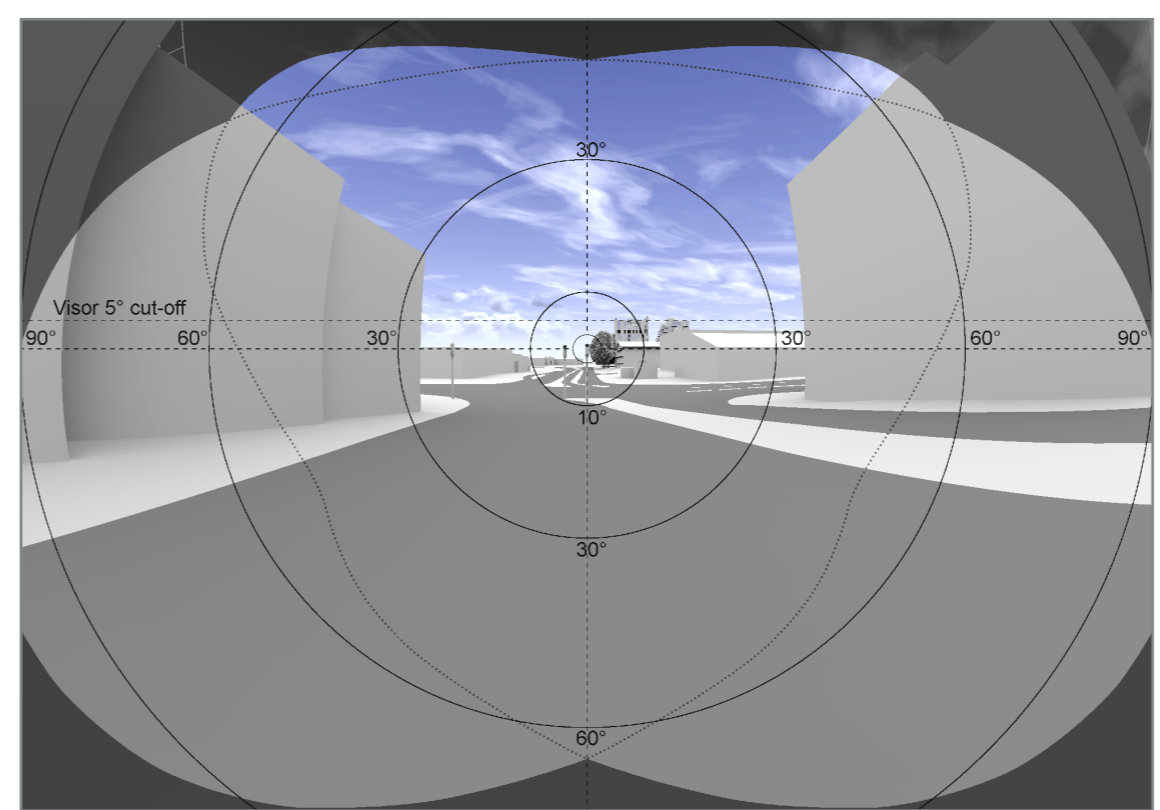

Fig. 106: Solar Glare - MONTHS - 180 degrees view

Project	Charlton Riverside Greenwich		
Reference	1864_R35_SG01		
Drawn	VL	Checked	JB
Date	29/11/2018	Rel no.	01
Drawing no.	1864_R35_SG01-27		

Title
 Reflected Solar Glare
 Frequency of Solar Reflections
 Existing Scenario
 Bare trees
 Viewpoint V4C

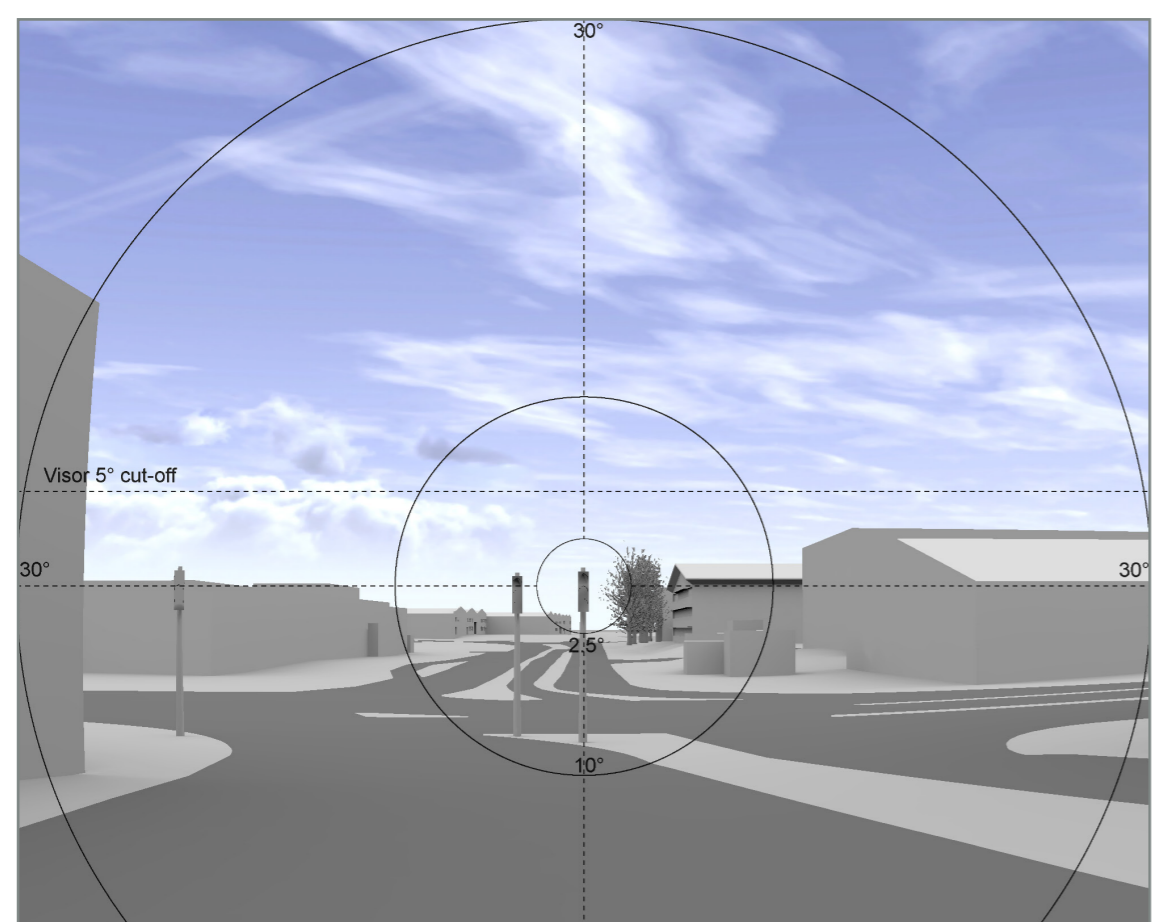

Fig. 107: Solar Glare - HOURS - Close-up

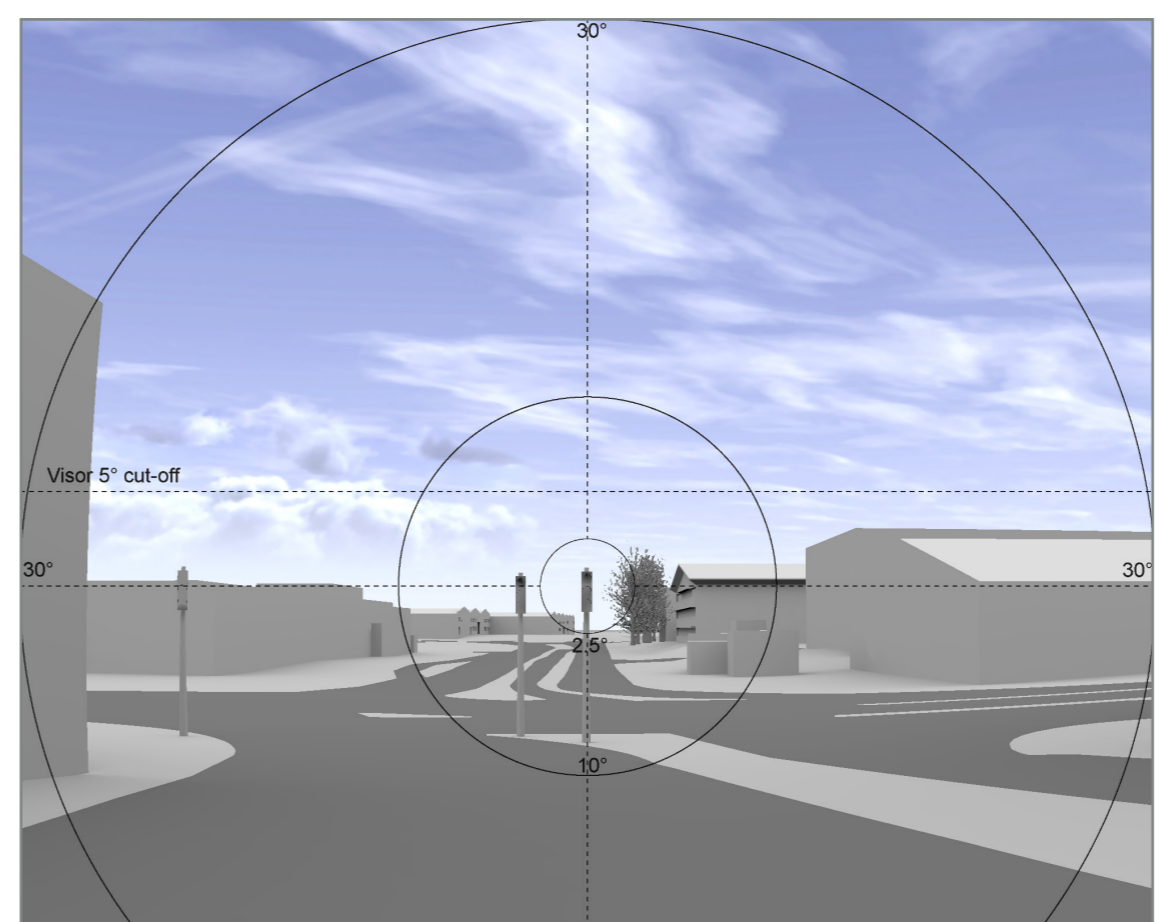
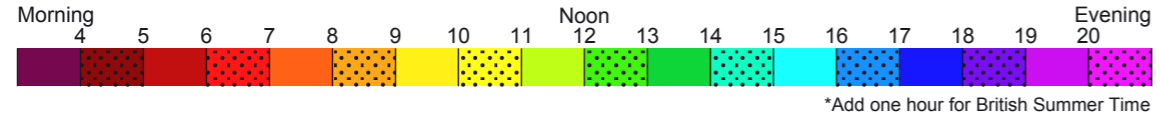

Fig. 108: Solar Glare - MONTHS - Close-up

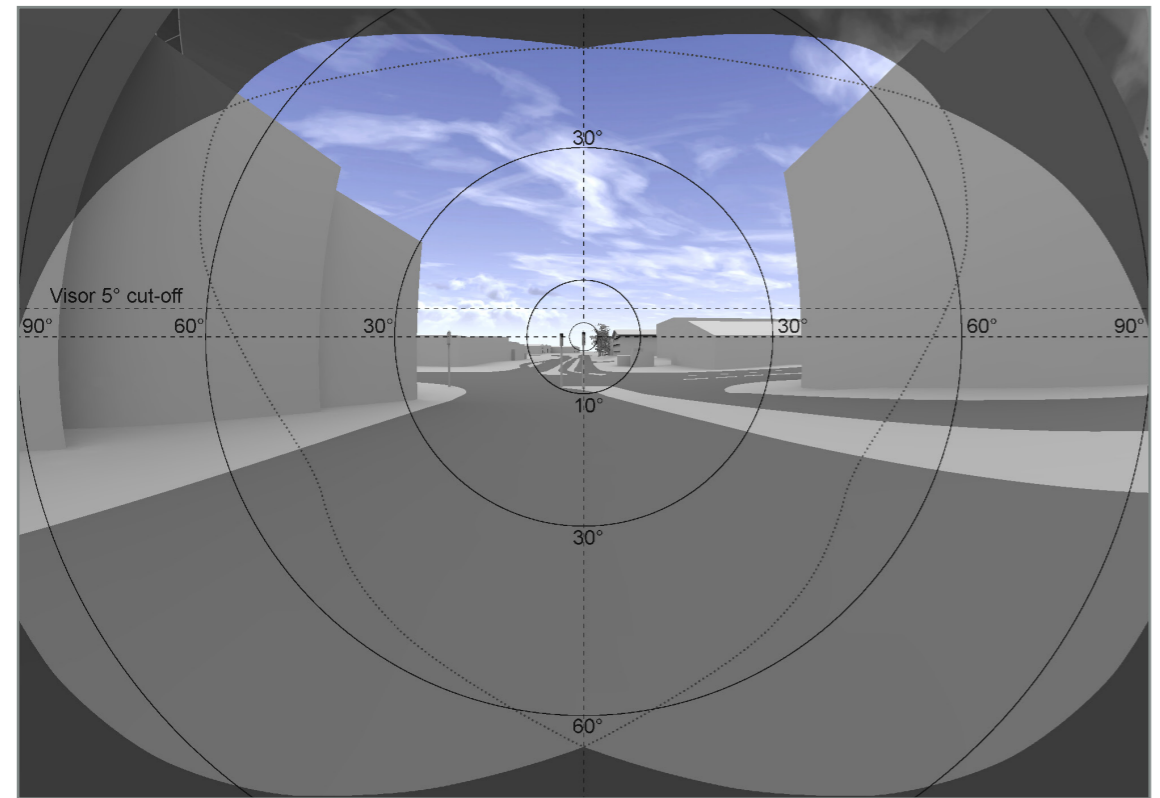
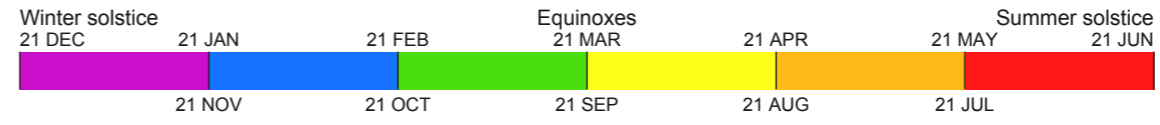

Fig. 109: Solar Glare - HOURS - 180 degrees view

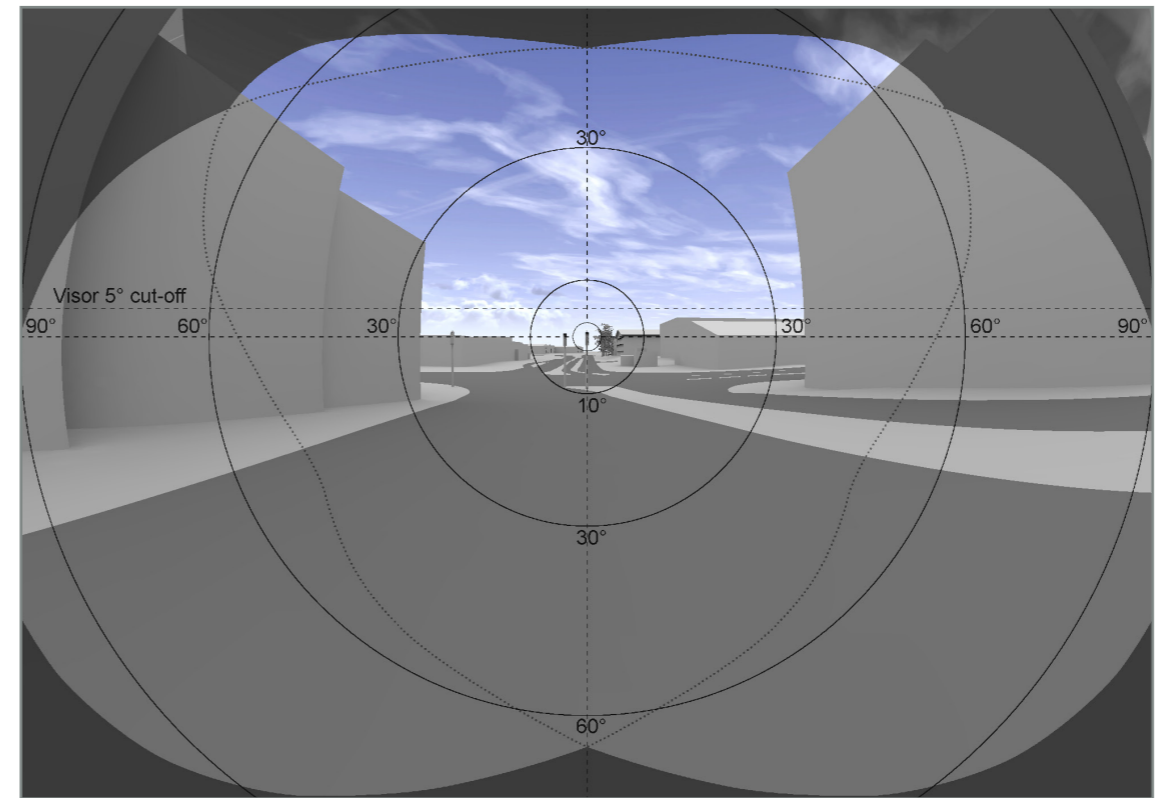

Fig. 110: Solar Glare - MONTHS - 180 degrees view

Project	Charlton Riverside Greenwich		
Reference	1864_R35_SG01		
Drawn	VL	Checked	JB
Date	29/11/2018	Rel no.	01
Drawing no.	1864_R35_SG01-28		

Title
 Reflected Solar Glare
 Frequency of Solar Reflections
 Proposed Scenario
 Bare trees
 Viewpont V5A

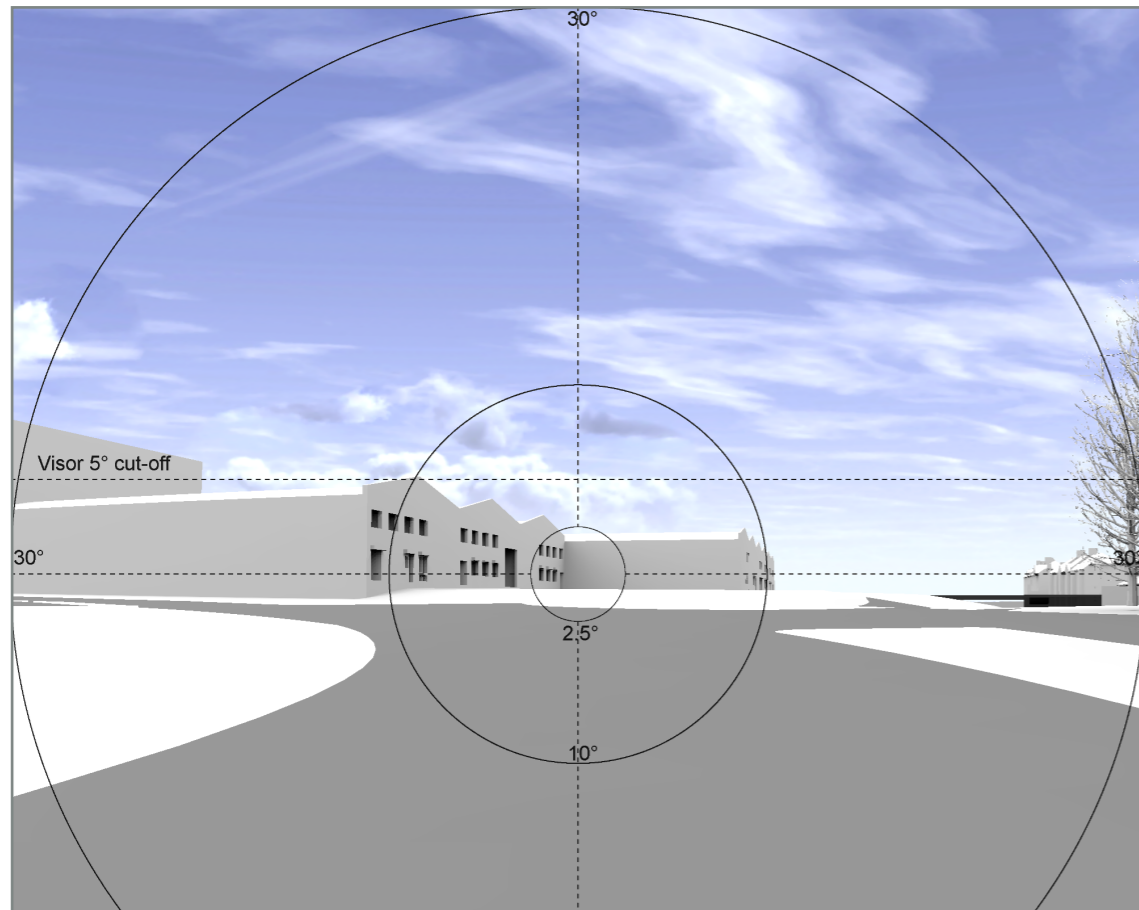

Fig. 111: Solar Glare - HOURS - Close-up

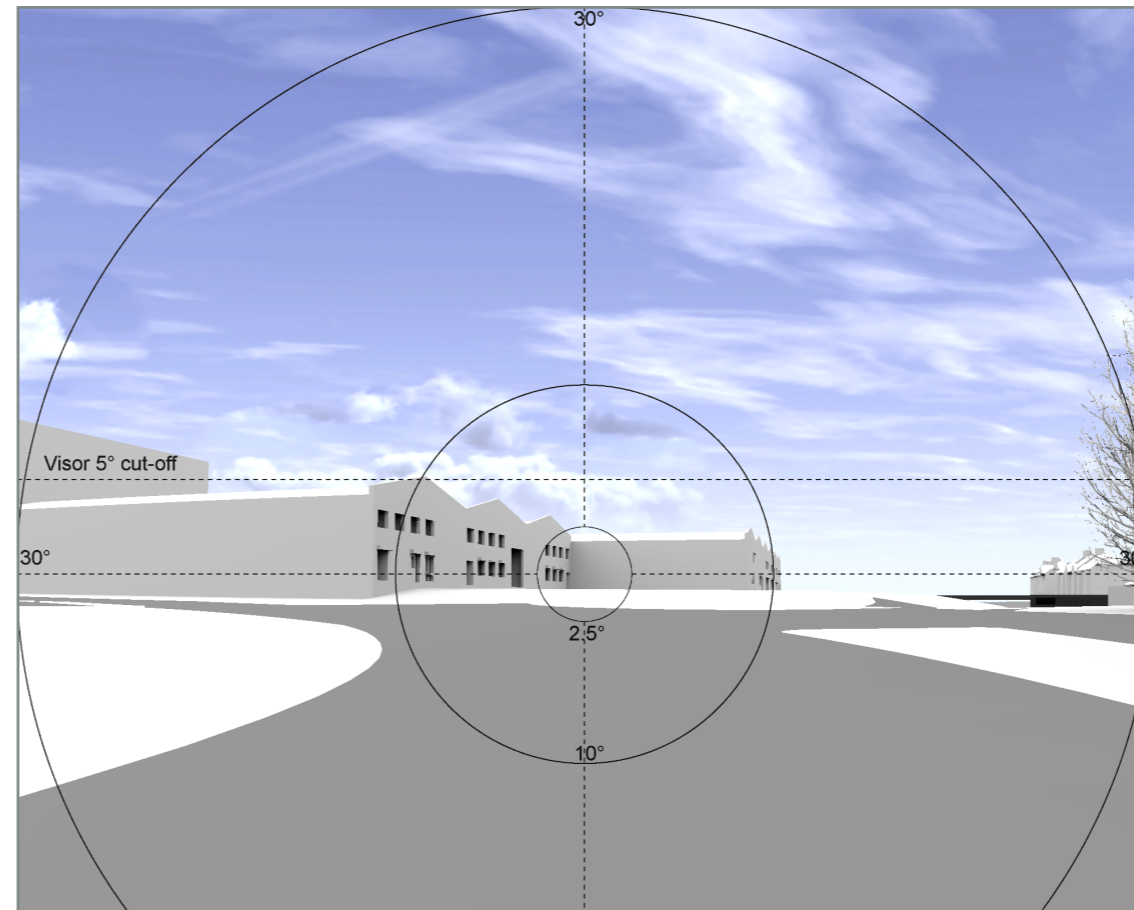
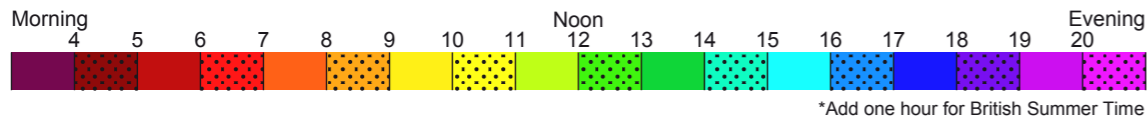

Fig. 112: Solar Glare - MONTHS - Close-up

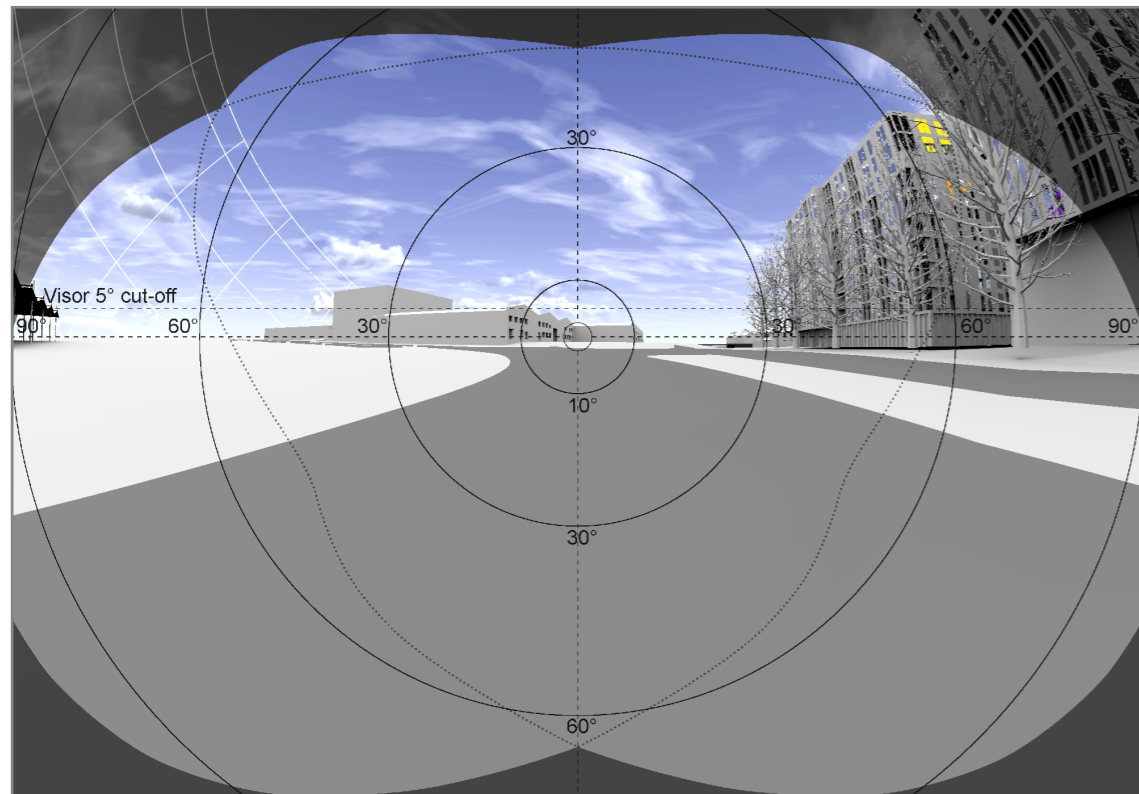
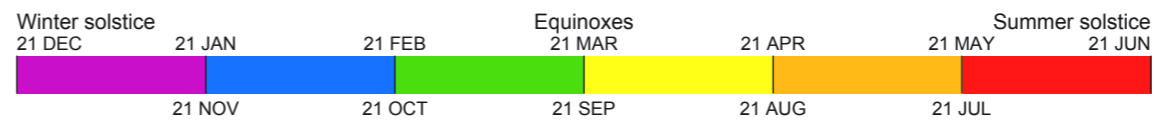

Fig. 113: Solar Glare - HOURS - 180 degrees view

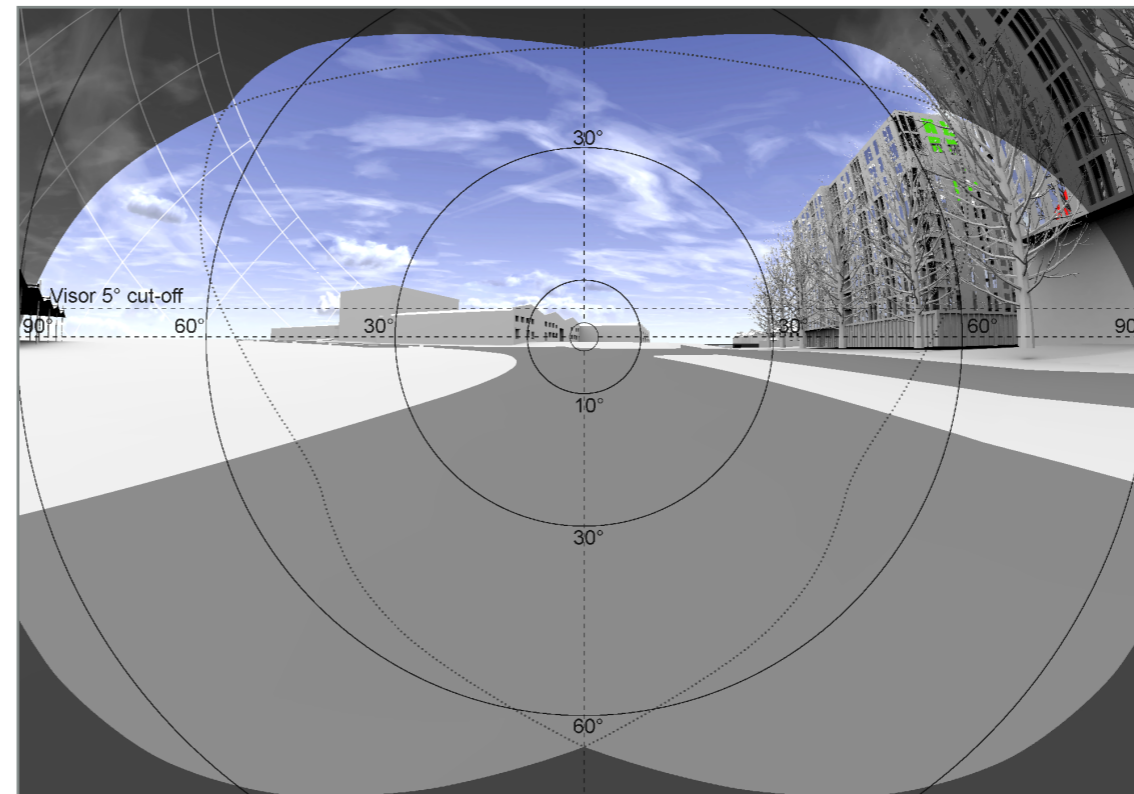

Fig. 114: Solar Glare - MONTHS - 180 degrees view

Title
 Reflected Solar Glare
 Frequency of Solar Reflections
 Proposed Scenario
 Trees in leaf
 Viewpoint V5A

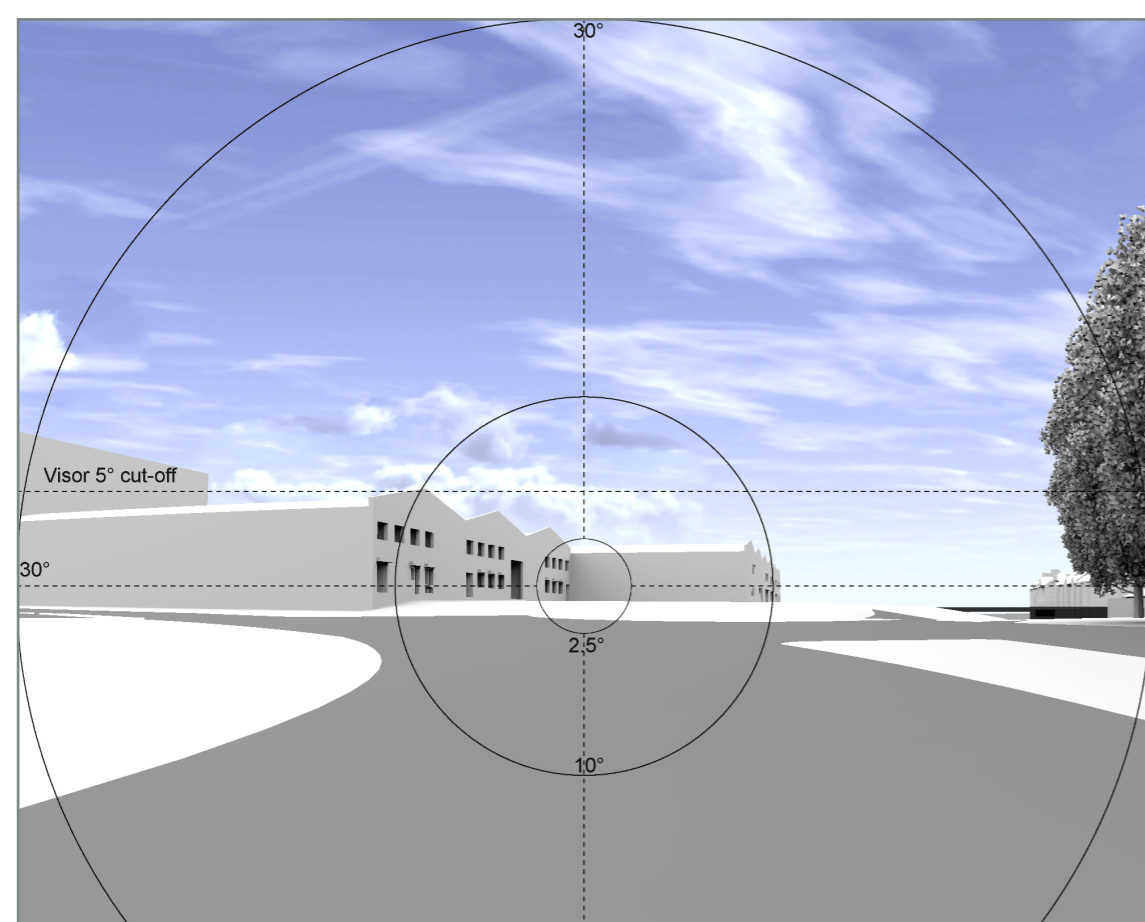

Fig. 115: Solar Glare - HOURS - Close-up

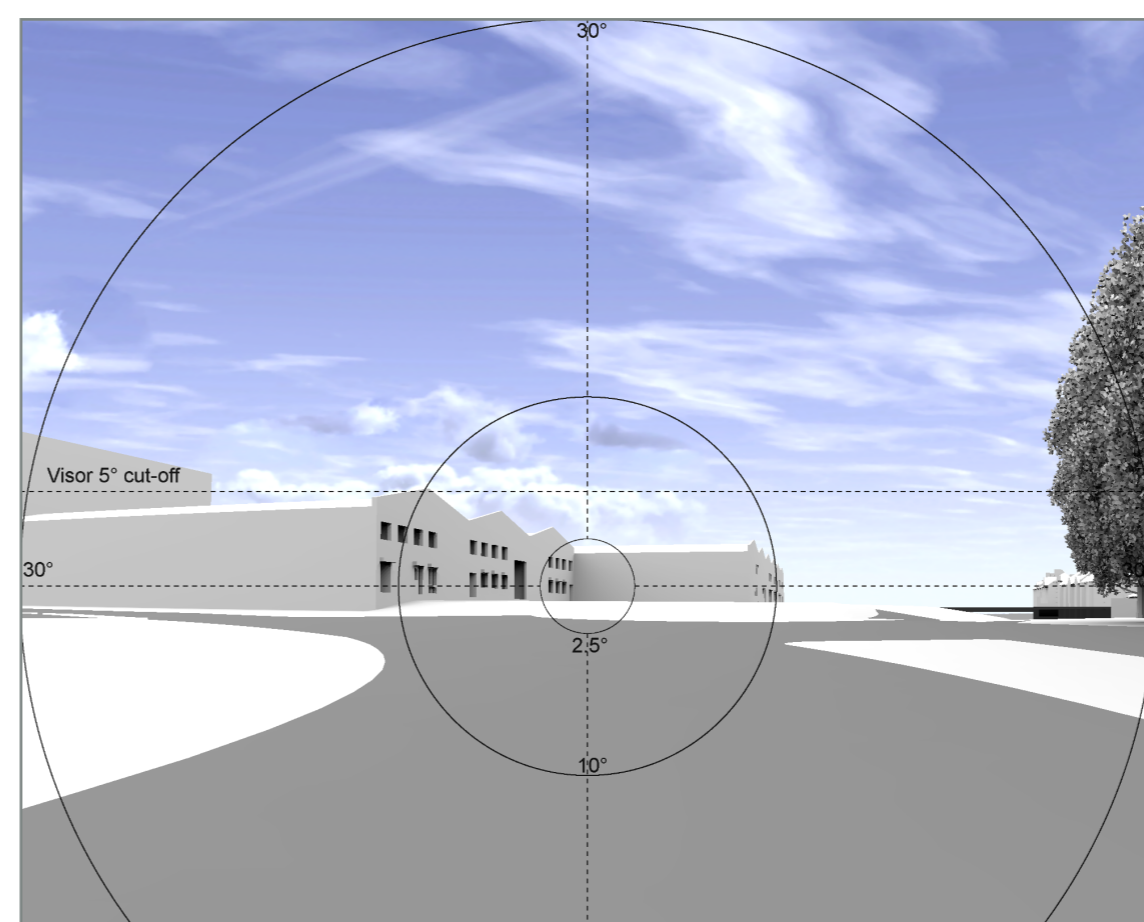
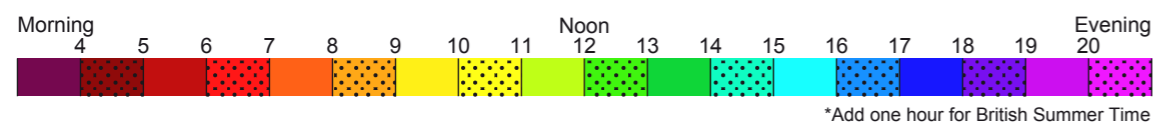

Fig. 116: Solar Glare - MONTHS - Close-up

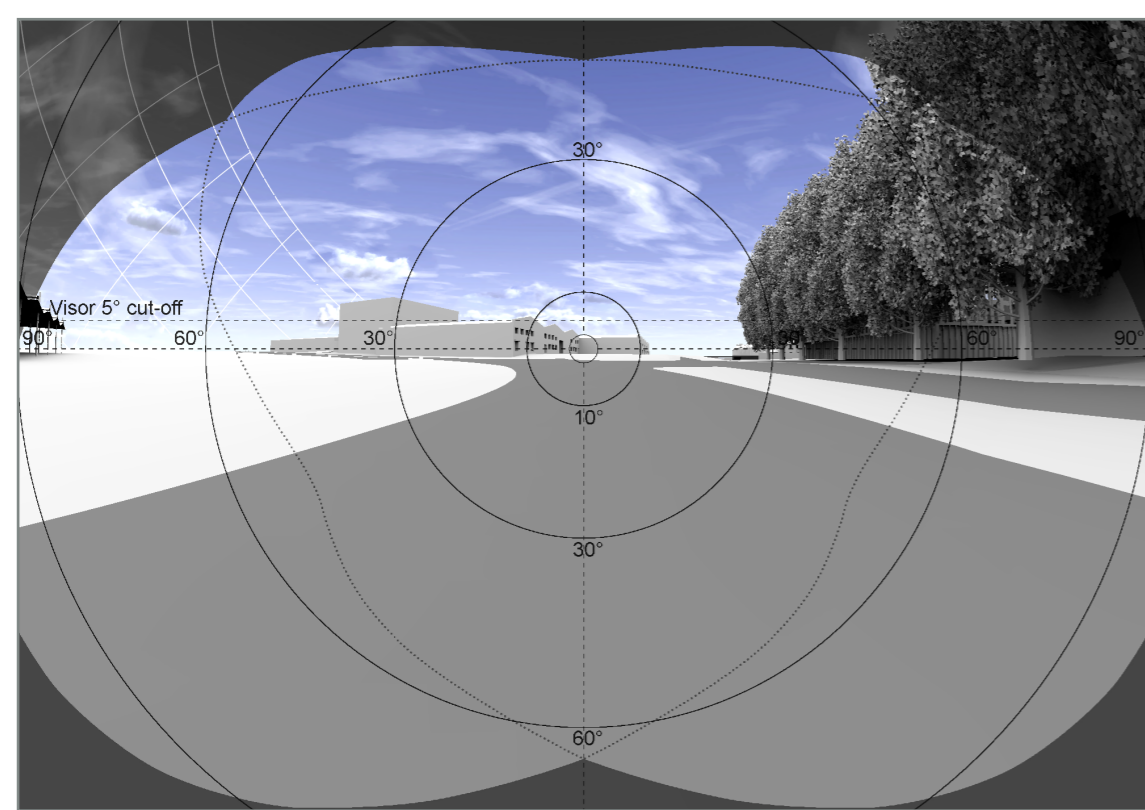
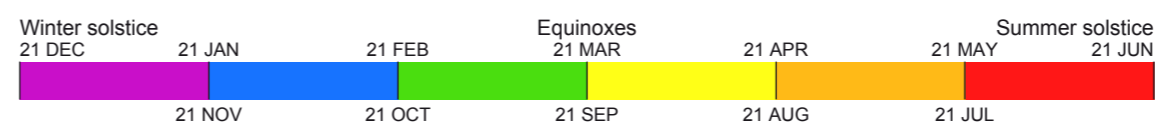

Fig. 117: Solar Glare - HOURS - 180 degrees view

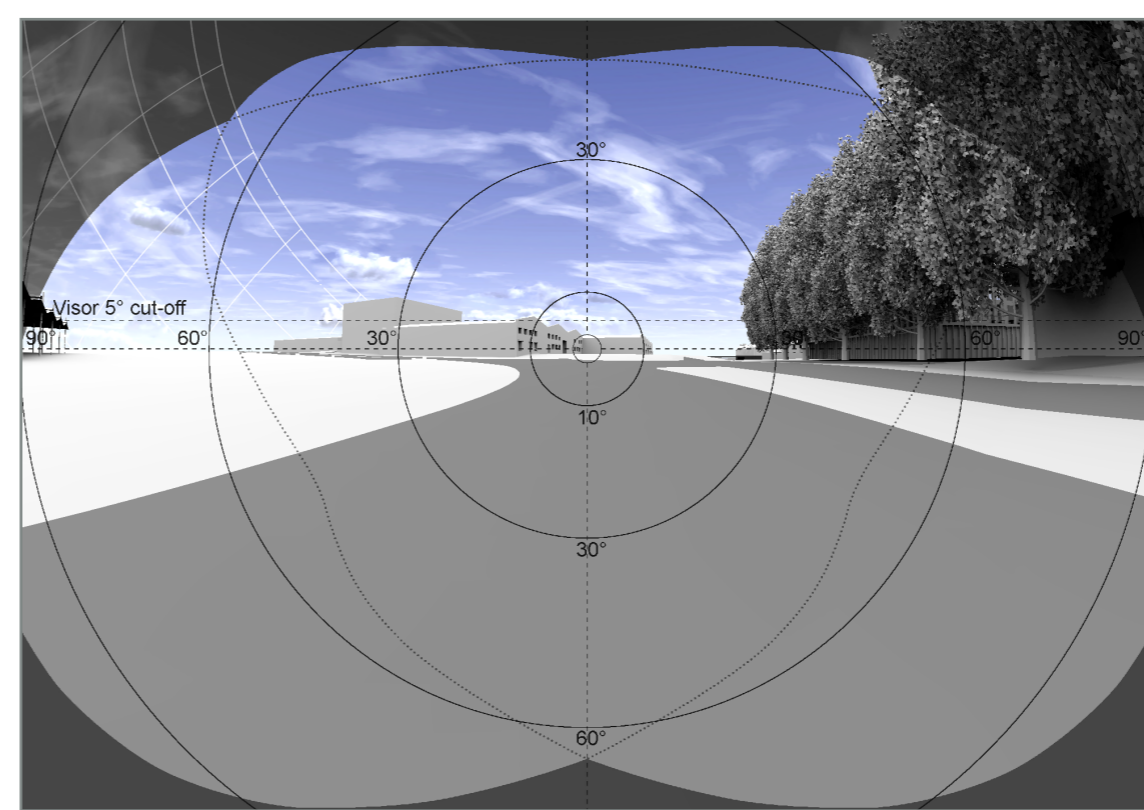

Fig. 118: Solar Glare - MONTHS - 180 degrees view

Project	Charlton Riverside Greenwich		
Reference	1864_R35_SG01		
Drawn	VL	Checked	JB
Date	29/11/2018	Rel no.	01
Drawing no.	1864_R35_SG01-30		

Title
 Reflected Solar Glare
 Frequency of Solar Reflections
 Existing Scenario
 Bare trees
 Viewpont V5A

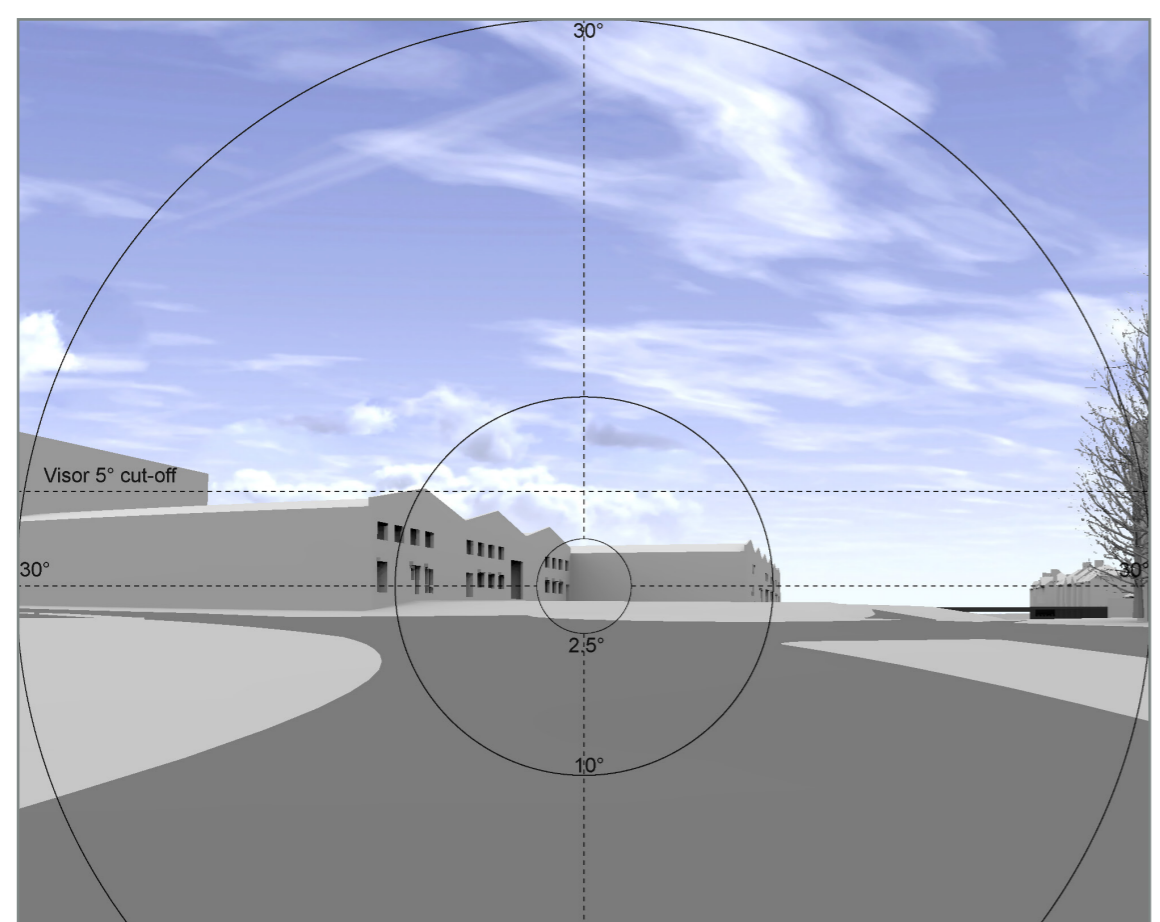

Fig. 119: Solar Glare - HOURS - Close-up

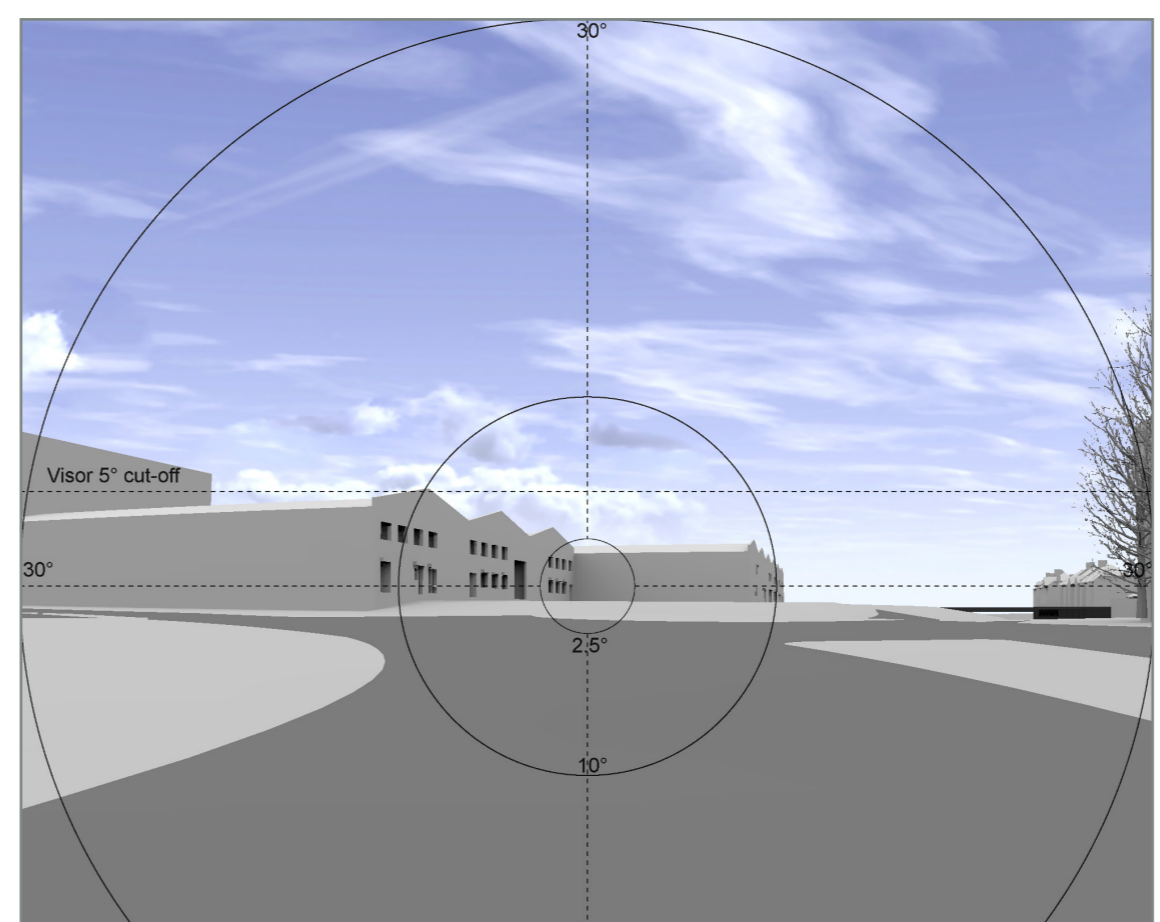
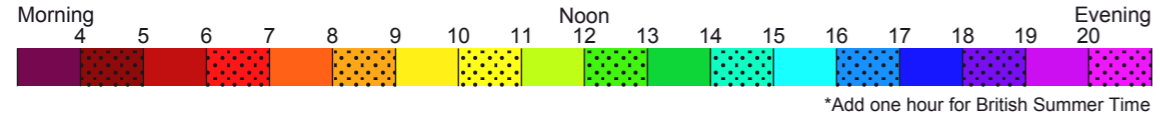

Fig. 120: Solar Glare - MONTHS - Close-up

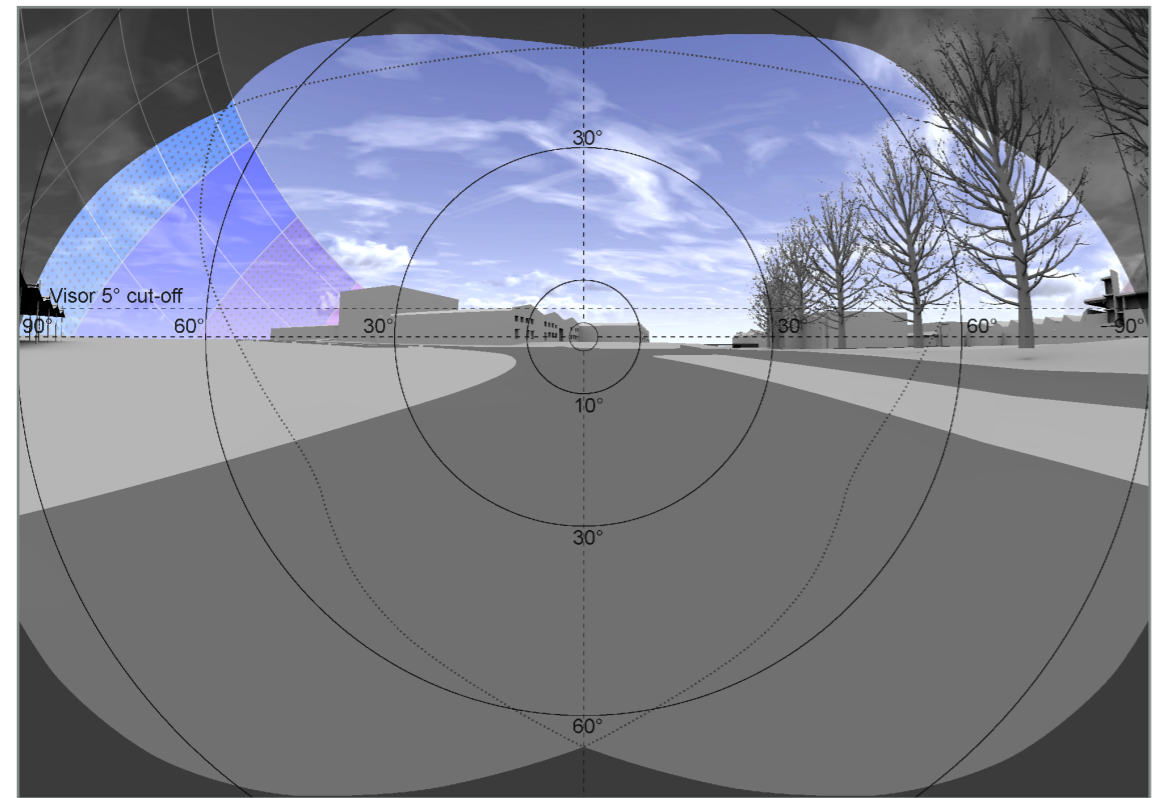
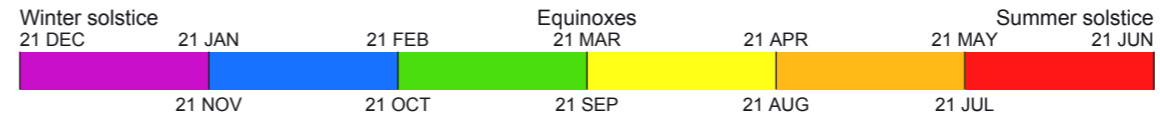

Fig. 121: Solar Glare - HOURS - 180 degrees view

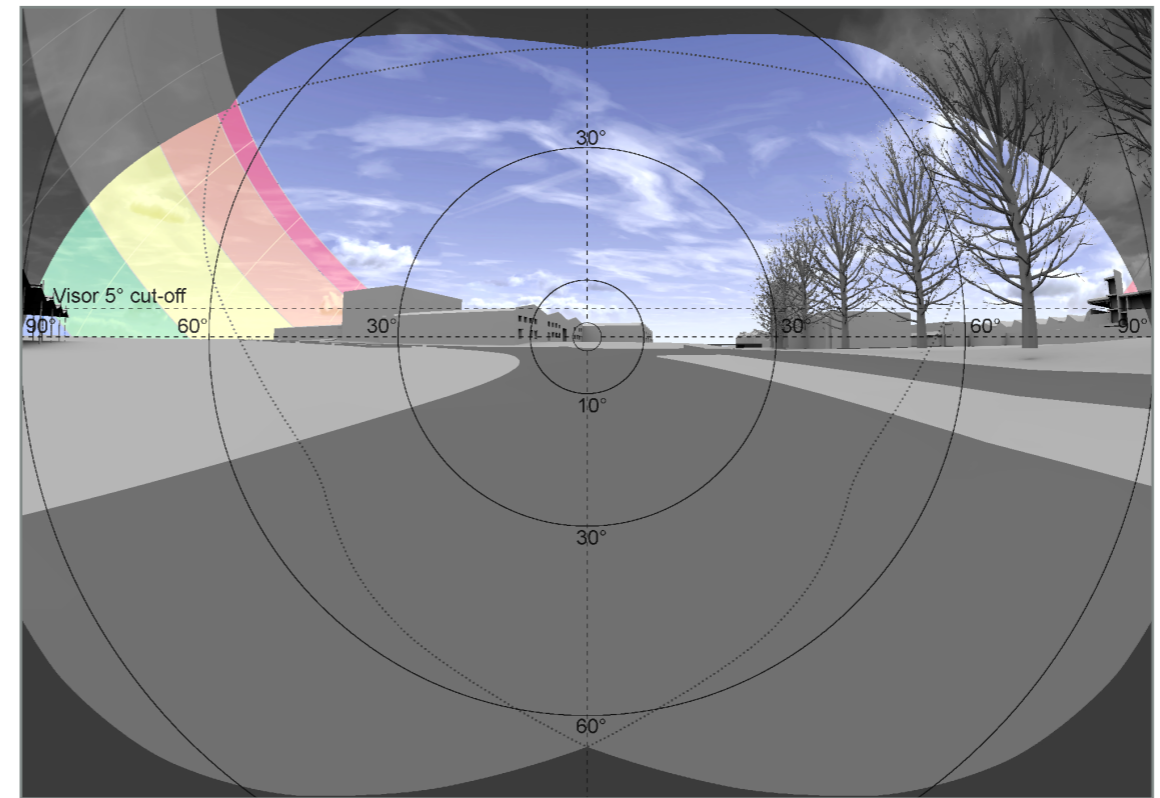

Fig. 122: Solar Glare - MONTHS - 180 degrees view

Project	Charlton Riverside Greenwich		
Reference	1864_R35_SG01		
Drawn	VL	Checked	JB
Date	29/11/2018	Rel no.	01
Drawing no.	1864_R35_SG01-31		

Title
 Reflected Solar Glare
 Frequency of Solar Reflections
 Proposed Scenario
 Bare trees
 Viewpont V5B

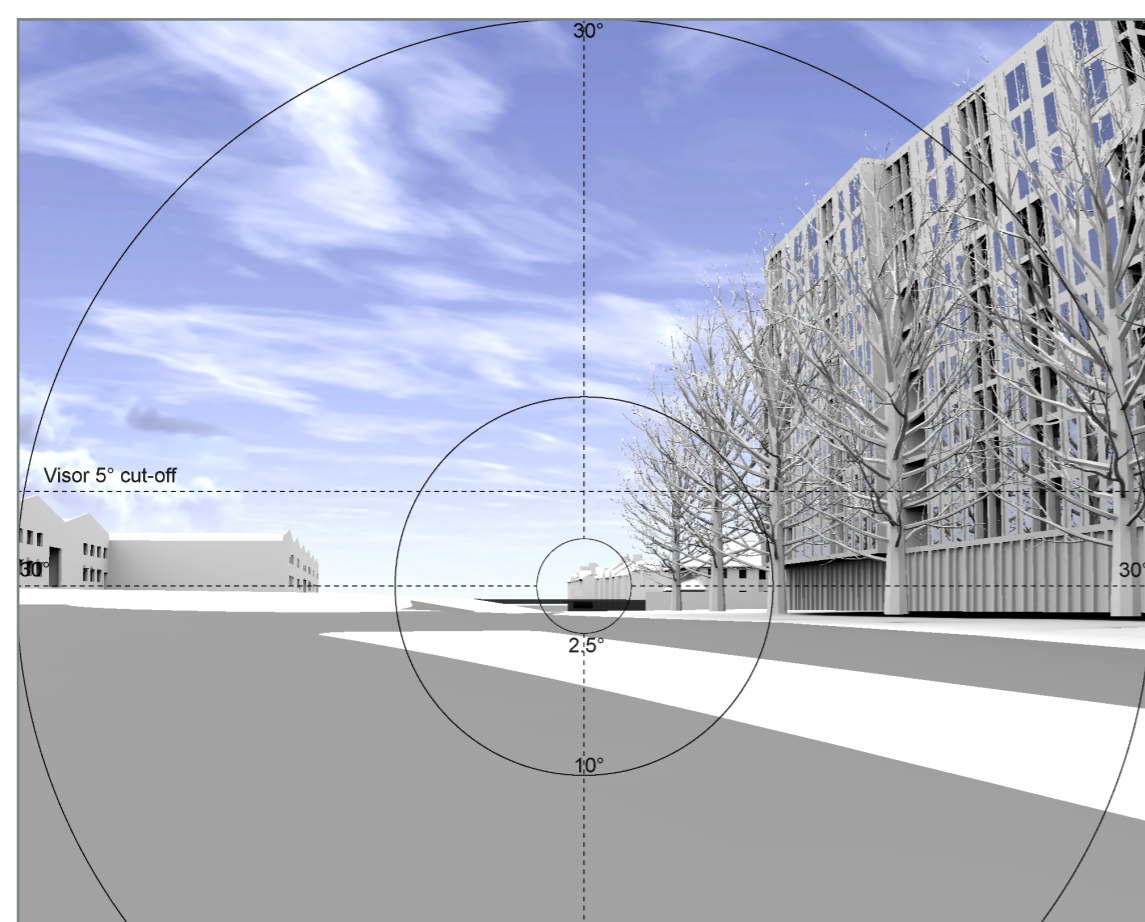

Fig. 123: Solar Glare - HOURS - Close-up

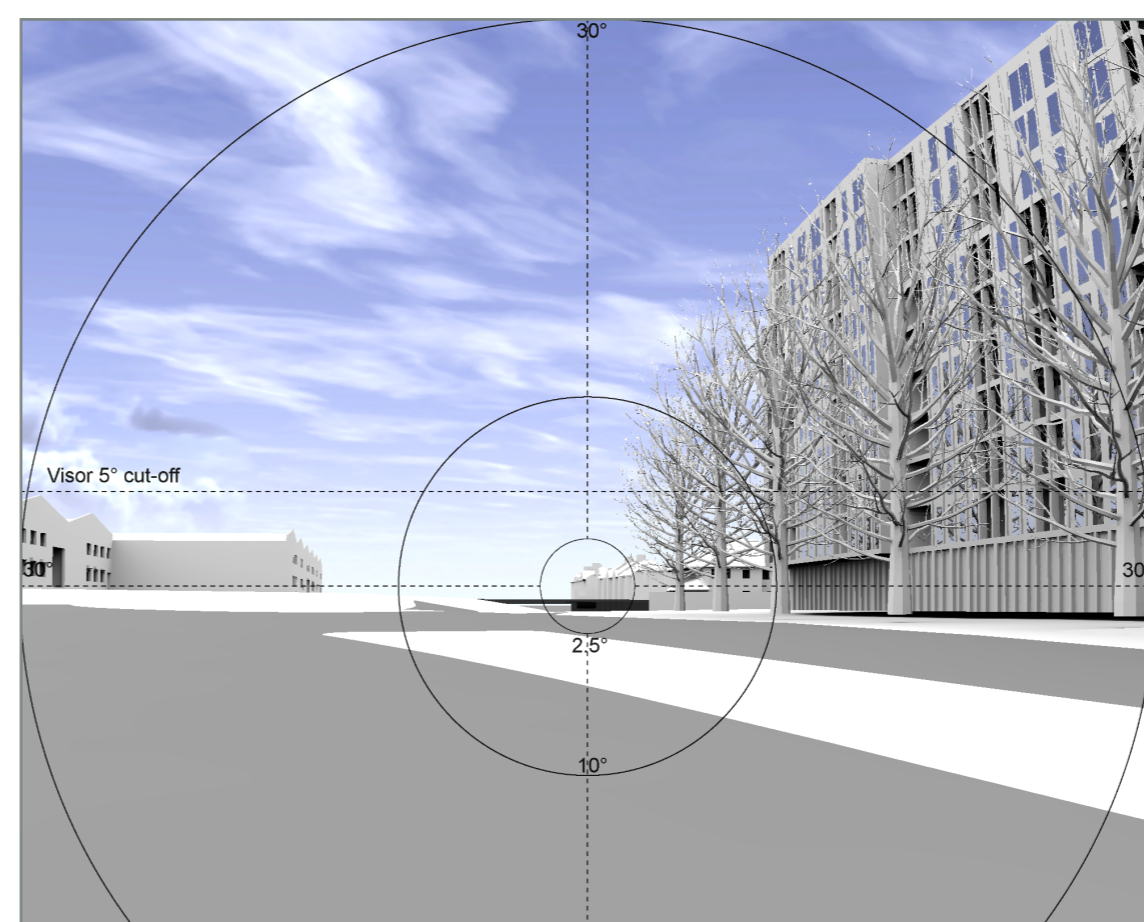
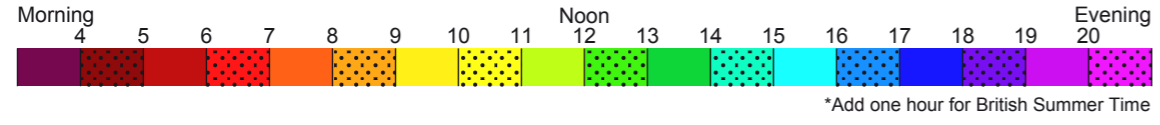

Fig. 124: Solar Glare - MONTHS - Close-up

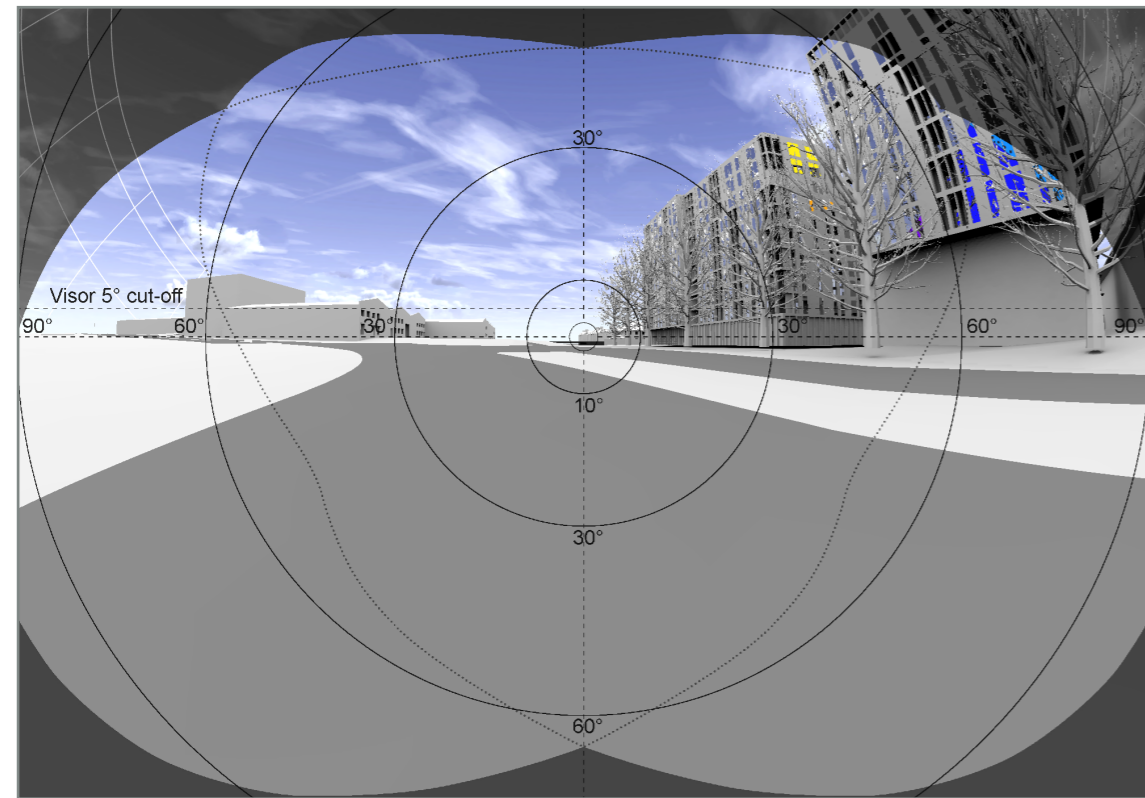
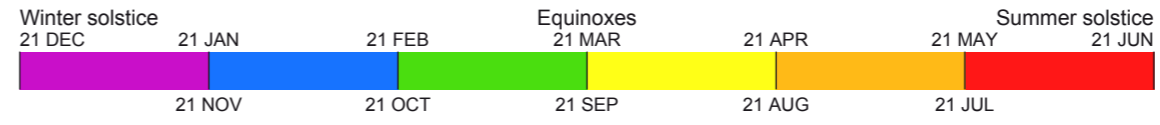

Fig. 125: Solar Glare - HOURS - 180 degrees view

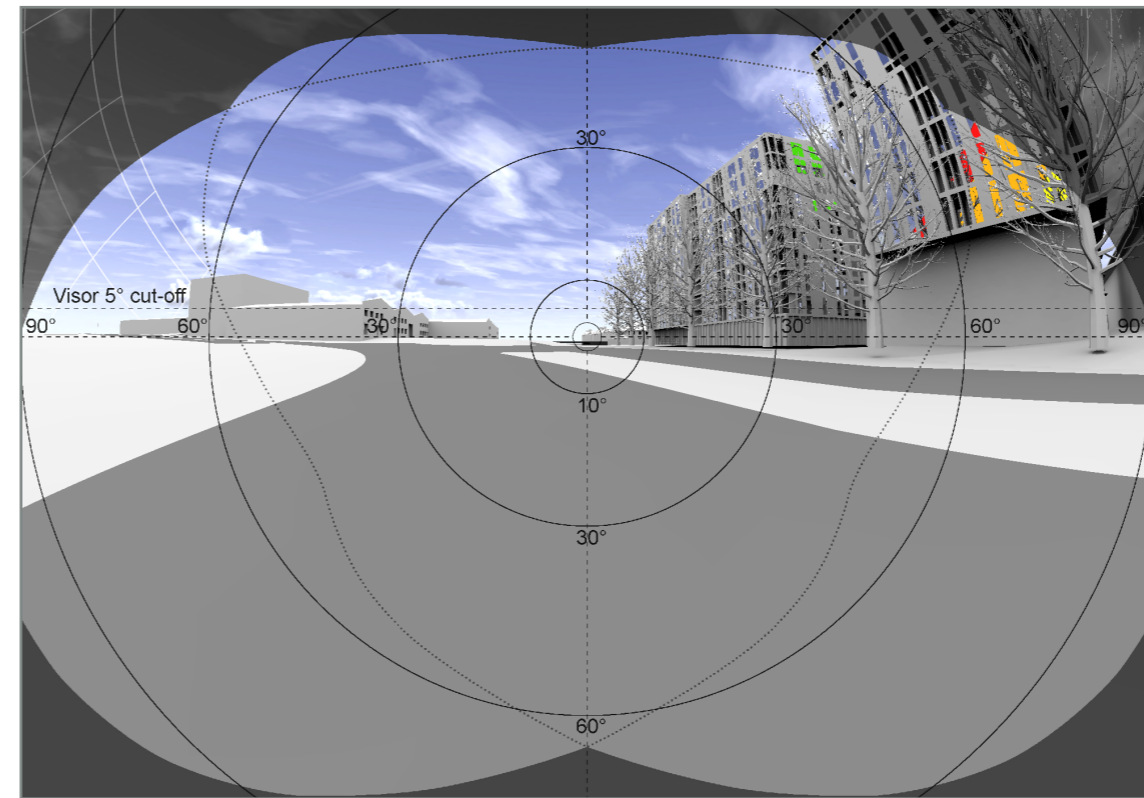

Fig. 126: Solar Glare - MONTHS - 180 degrees view

Project	Charlton Riverside Greenwich		
Reference	1864_R35_SG01		
Drawn	VL	Checked	JB
Date	29/11/2018	Rel no.	01
Drawing no.	1864_R35_SG01-32		

Title
 Reflected Solar Glare
 Frequency of Solar Reflections
 Proposed Scenario
 Trees in leaf
 Viewpoint V5B

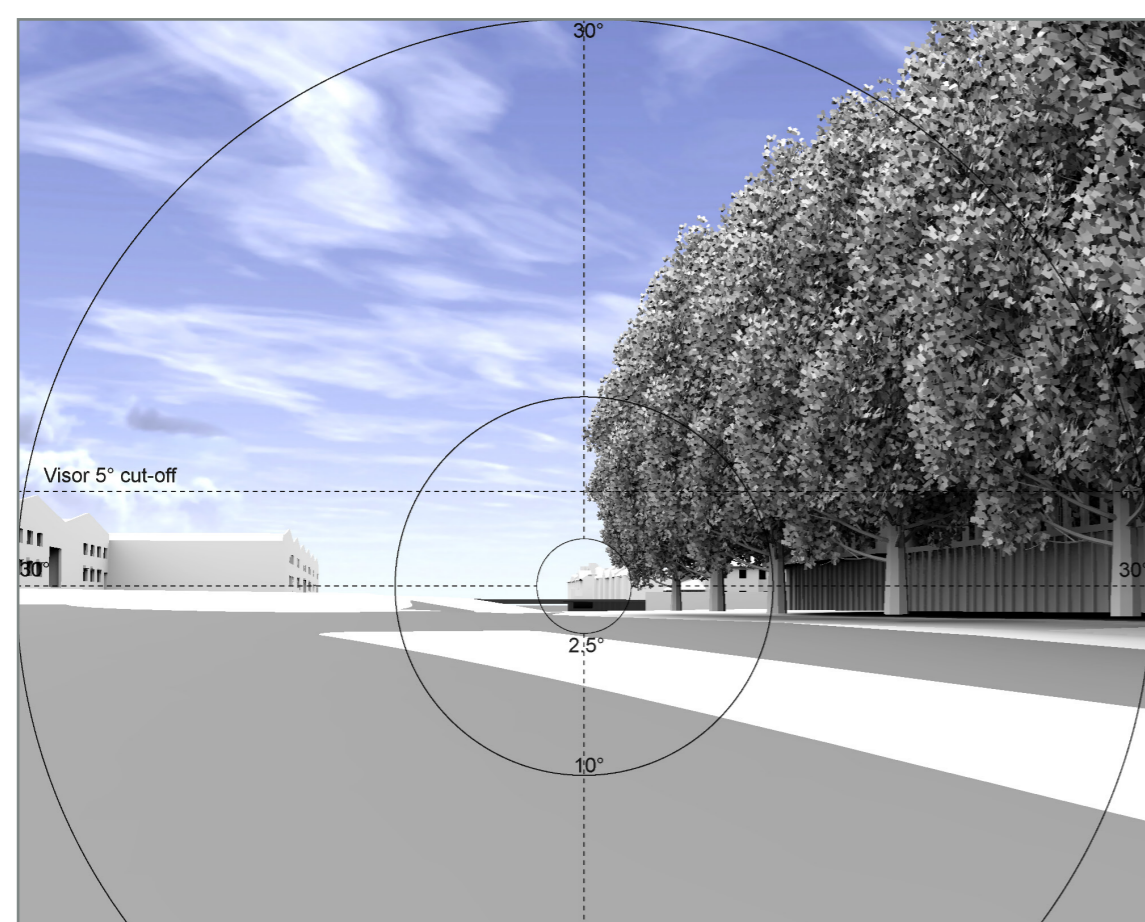

Fig. 127: Solar Glare - HOURS - Close-up

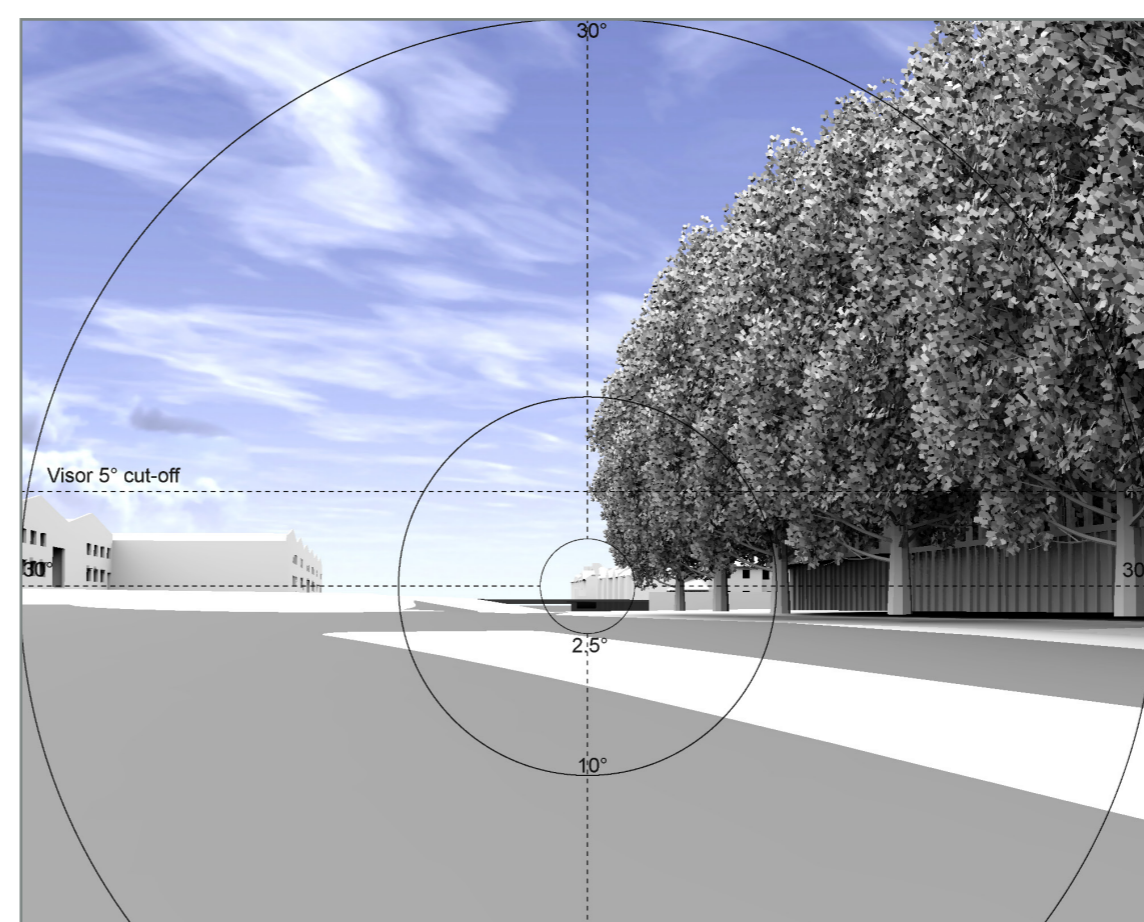
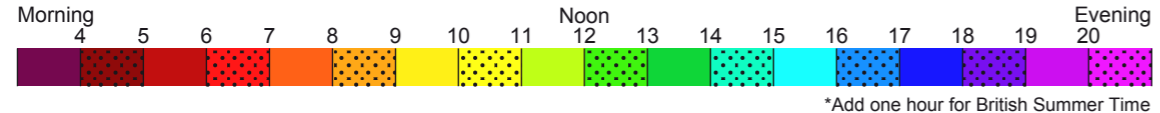

Fig. 128: Solar Glare - MONTHS - Close-up

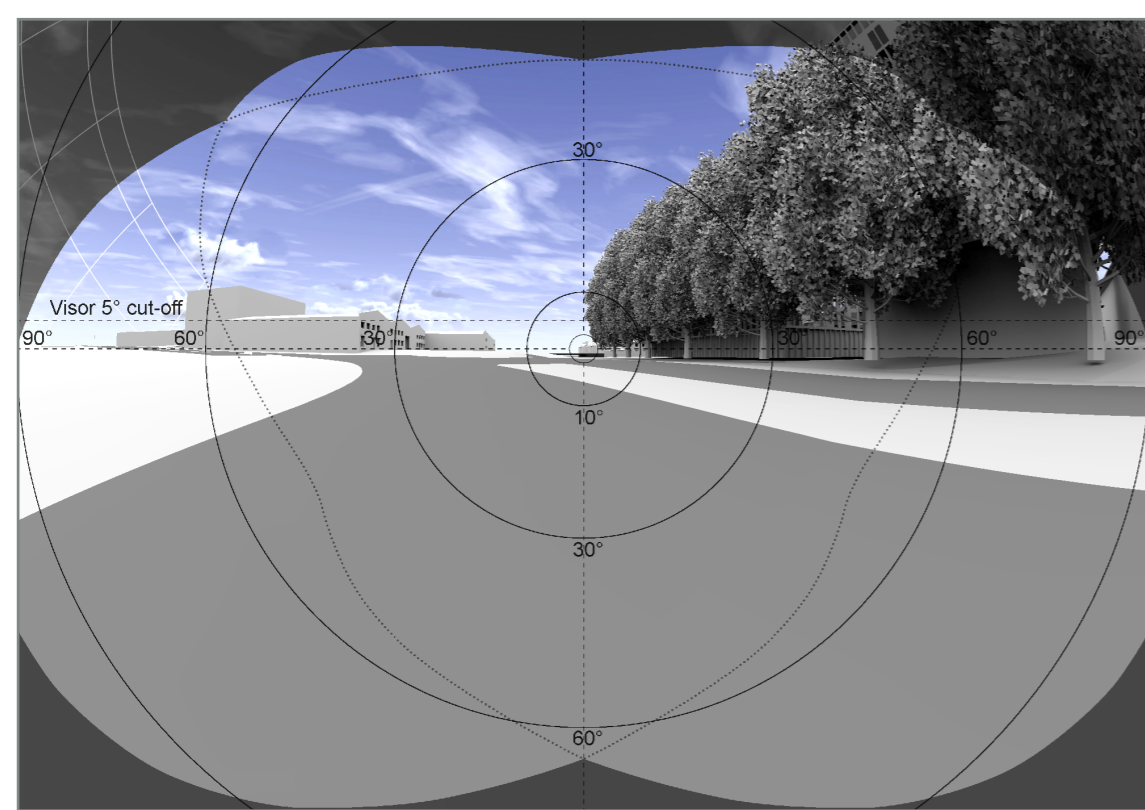
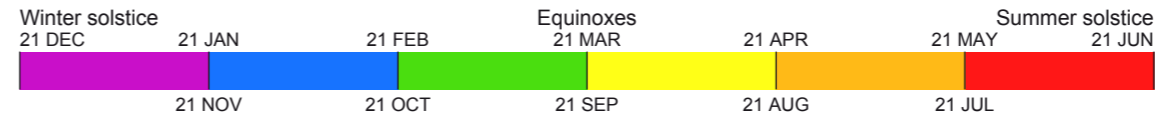

Fig. 129: Solar Glare - HOURS - 180 degrees view

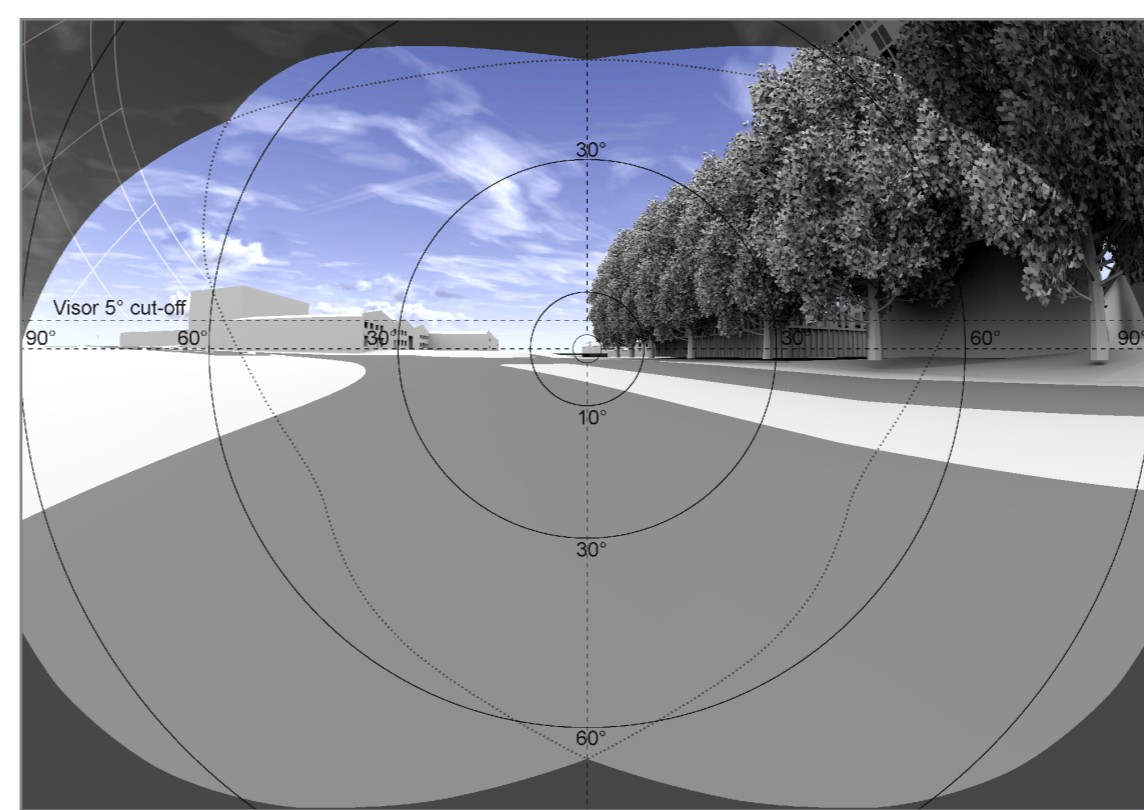

Fig. 130: Solar Glare - MONTHS - 180 degrees view

Project	Charlton Riverside Greenwich		
Reference	1864_R35_SG01		
Drawn	VL	Checked	JB
Date	29/11/2018	Rel no.	01
Drawing no.	1864_R35_SG01-33		

Title
 Reflected Solar Glare
 Frequency of Solar Reflections
 Existing Scenario
 Bare trees
 Viewpont V5B

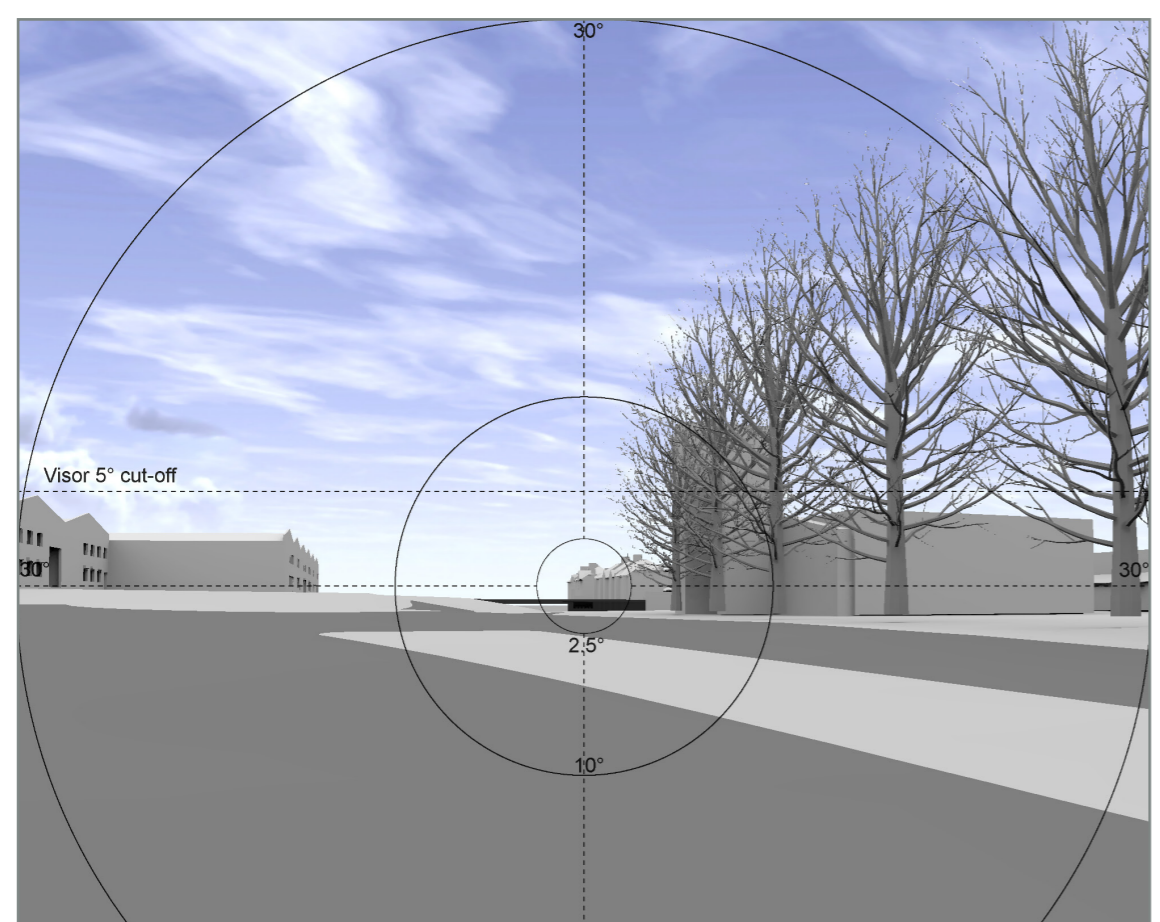

Fig. 131: Solar Glare - HOURS - Close-up

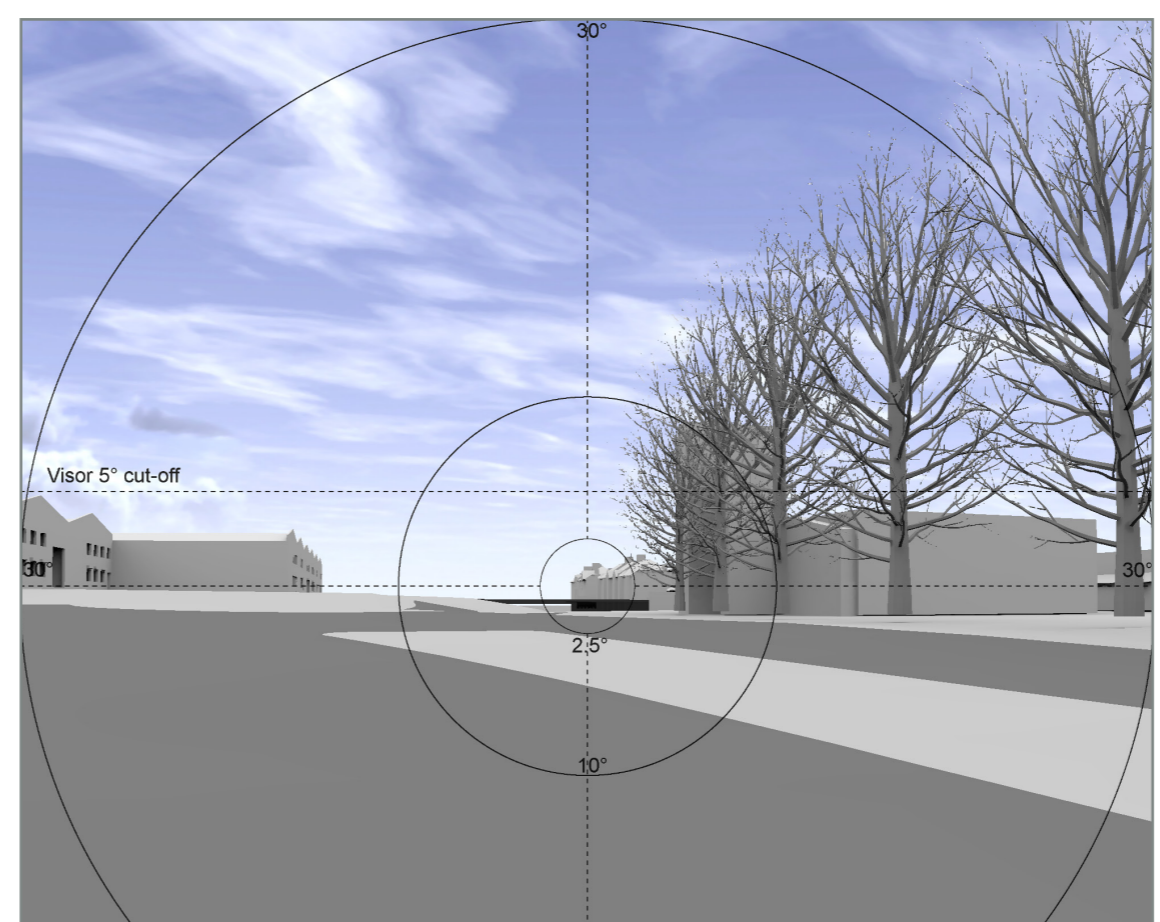
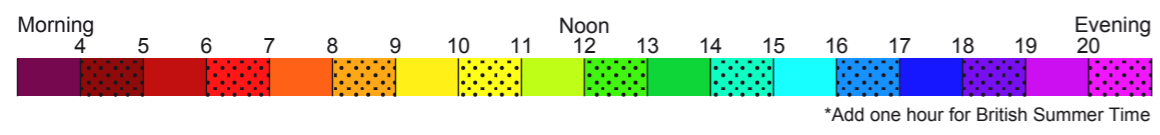

Fig. 132: Solar Glare - MONTHS - Close-up

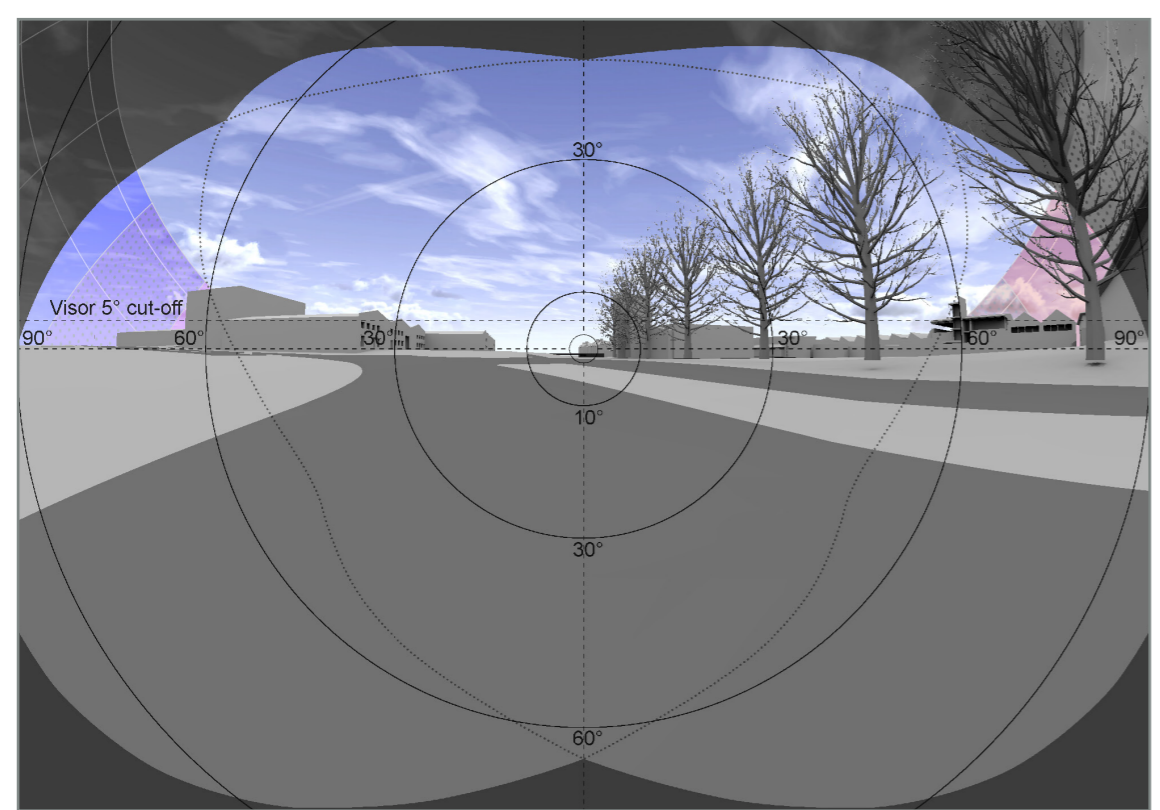
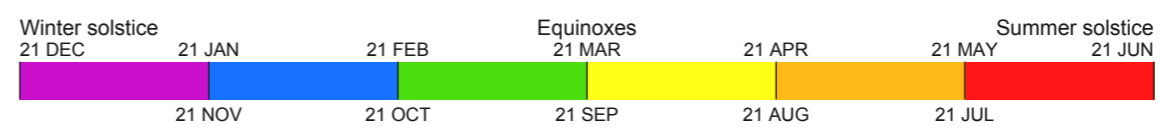

Fig. 133: Solar Glare - HOURS - 180 degrees view

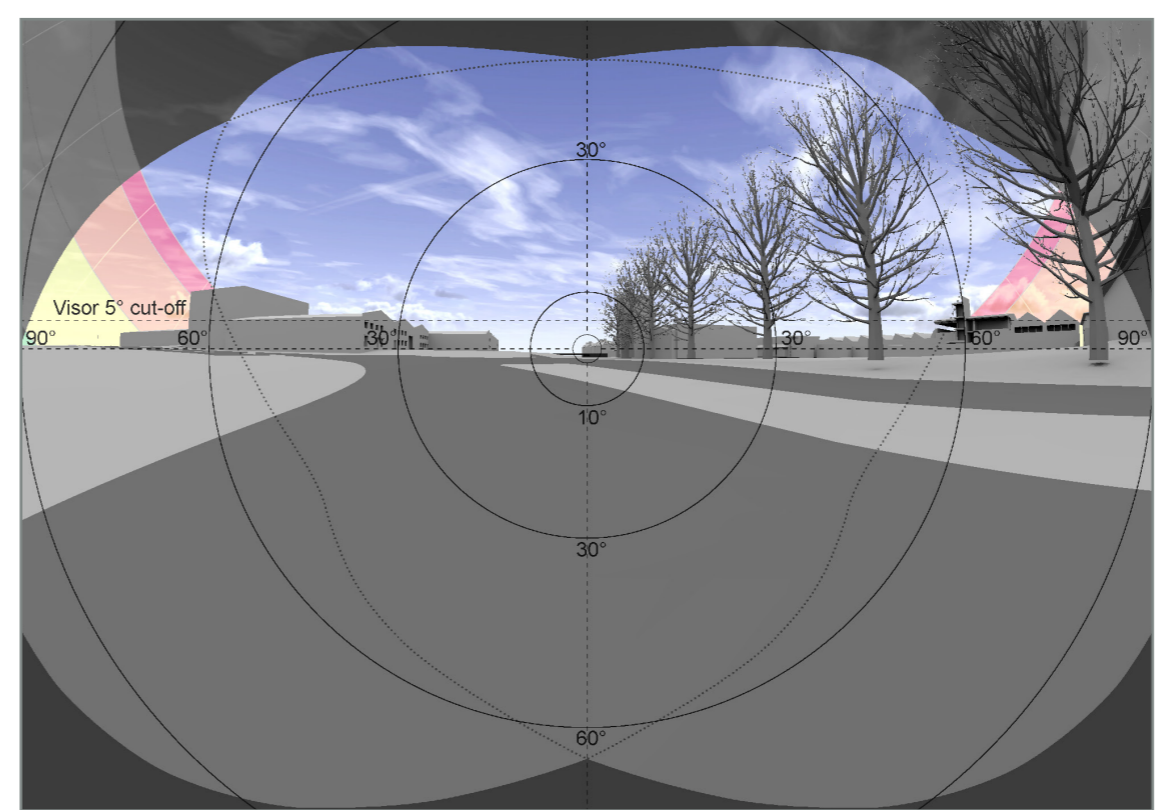

Fig. 134: Solar Glare - MONTHS - 180 degrees view

Project	Charlton Riverside Greenwich		
Reference	1864_R35_SG01		
Drawn	VL	Checked	JB
Date	29/11/2018	Rel no.	01
Drawing no.	1864_R35_SG01-34		