



1 Bi.PLN 07
06157 1 : 150

SUPPLEMENTARY INFORMATION:
 These drawings reflect the current position of the scheme development at RIBA Stage 2, they should be read in conjunction with the following information prepared by Morris+Company:
 - Aberfeldy Village, Phase A, Design and Access Statement
 Drawings should be read in conjunction with information prepared by other consultants (where applicable):
 - Landscape Design Drawings (LDA)
 - Structural Engineers Drawings and Specification, (MEINHARDT)
 - MEP Engineers Drawings and Specification, (MEINHARDT)

EXTENTS AND BOUNDARIES:
 These drawings combine survey and site information produced by others and as such should be verified for accuracy.
 Existing site information, context, surrounding infrastructure, neighboring building extents and plots are derived from 2D Surveys, produced by:

'Sumo Services Ltd'
 Drawing numbers: SOR018502 / SOR018561/ SOR018539
 Date of creation: 17.12.2020 / 14.01.2021 / 09.12.2019

'Aworth Survey Consultants'
 Drawing numbers: 3553-2/5/6/7
 Date of creation: 18.12.2009

The application boundary has been derived by title plan and land ownership reports and produced by:
 Velocity Transport
 Drawing no: 4060-1100-T-023
 Produced: Dec 20

Spot levels are defined as AOD and reflected in metres

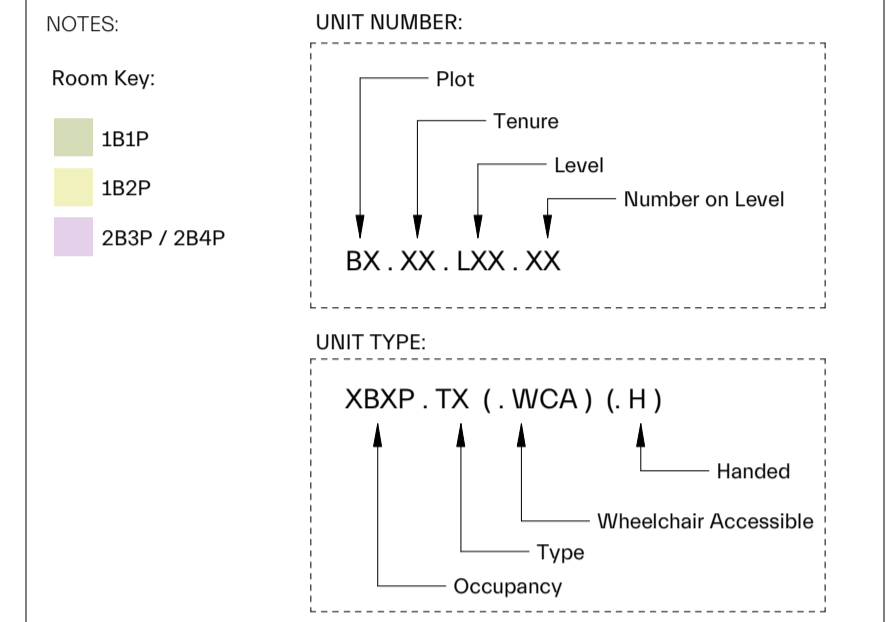

P06	30-01-2023	Planning Addendum 2 Stair Adjustments
P05	25-01-2023	Planning Addendum 2 Stair Adjustments
P04	09-09-2022	GLA Stage 1 Fire Adjustments
P03	25-03-2022	Planning Revision A
P02	15-10-2021	Planning
P01	01-10-2021	Amendments Pre Planning Submission

revision date amendment

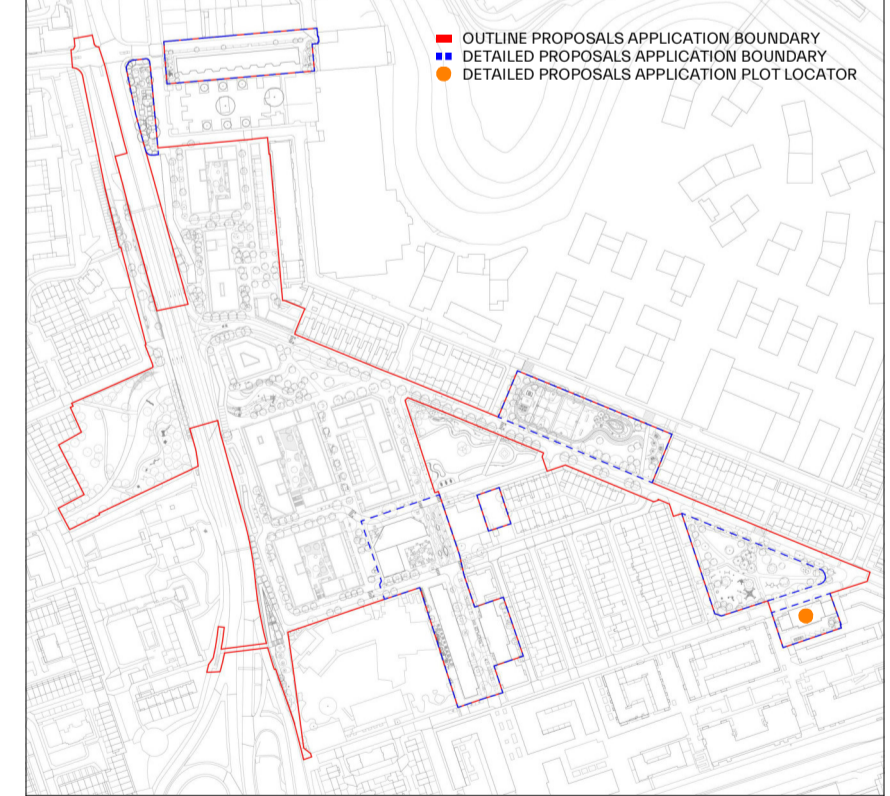
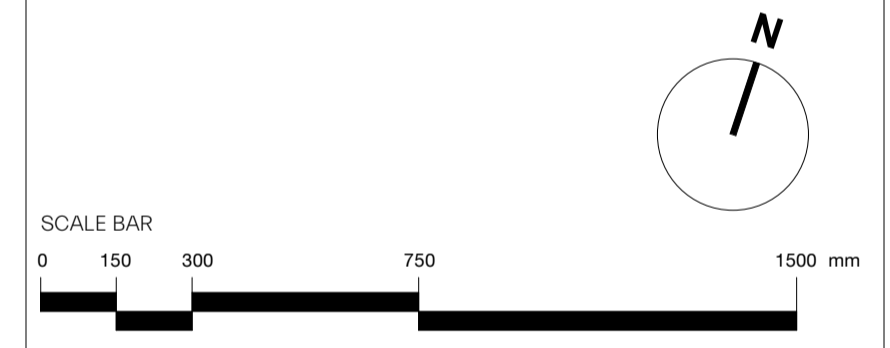

MORRIS+COMPANY
 15 Mare Street, London, E8 3QE
 Tel: +44 (0)20 7566 7440
 www.morrisandcompany.com

- Do not scale from this drawing
 - All dimensions to be checked on site by the Contractor
 - And such dimensions to be their responsibility
 - Report all drawing errors and omissions to the Architect
 - All dimensions in millimeters unless noted otherwise
 - If in doubt ask Contract Administrator

job title		Aberfeldy Village					
drawing title /		PLOT i - PROPOSED SEVENTH FLOOR PLAN					
status	S4 - FOR APPROVAL						
scale	As indicated @ A1						
project	originator	zone	level	type	role	number	revision
A303	MCO	Bi	07	DR	A	06157	P06