

Key Information	3B4P Requirement	Achieving
Kitchen Length (m)	5.9	5.9
Storage Area (m ²)	2.0	2.5
L/K/D (m ²)	29	31

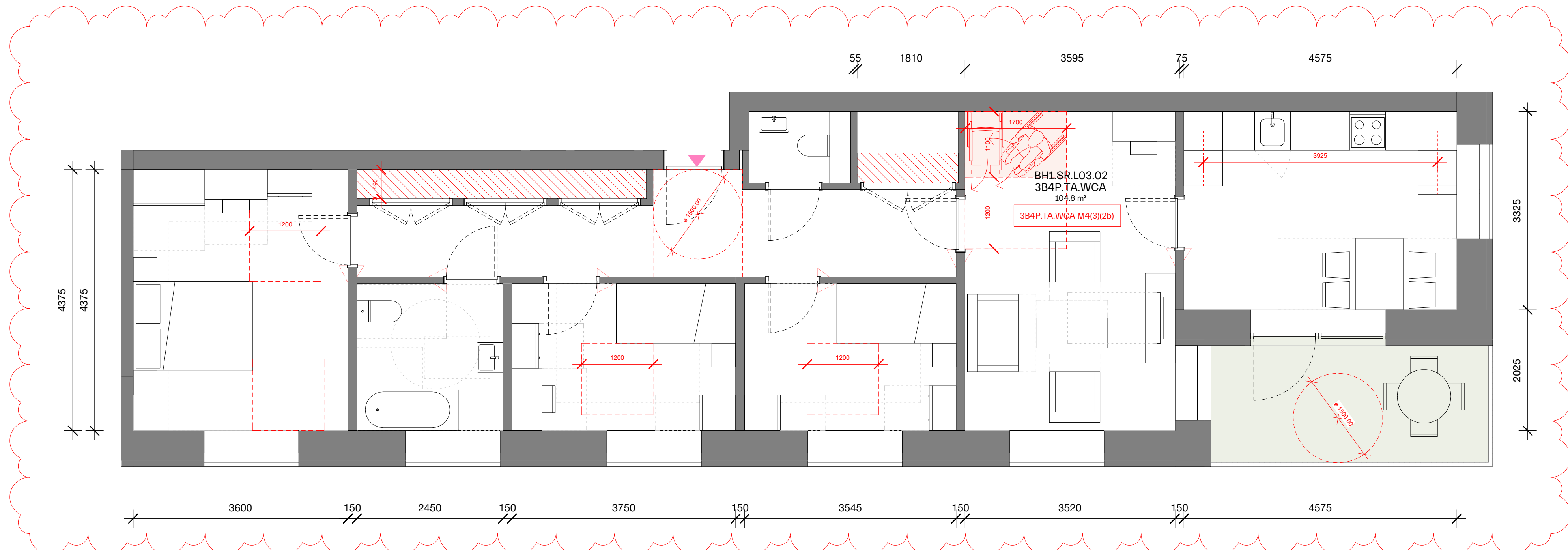

3 BH1 PLD 50_3B4P_Type A_WCA_L03-07
06431 1 : 50



2 BH1 PLD 50_3B5P_Type B_L03-07
06431 1 : 50

SUPPLEMENTARY INFORMATION:
These drawings reflect the current position of the scheme development at RIBA Stage 2, they should be read in conjunction with the following information prepared by Morris+Company:
- Aberfeldy Village, Phase A, Design and Access Statement
Drawings should be read in conjunction with information prepared by other consultants (where applicable):
- Landscape Design Drawings (LDA)
- Structural Engineers Drawings and Specification, (MEINHARDT)
- MEP Engineers Drawings and Specification, (MEINHARDT)

EXTENTS AND BOUNDARIES:
These drawings combine survey and site information produced by others and as such should be verified for accuracy.

Existing site information, context, surrounding infrastructure, neighboring building extents and plots are derived from 2D Surveys, produced by:

'Sumo Services Ltd'
Drawing numbers: SOR018502 / SOR018561/ SOR018539
Date of creation: 17.12.2020 / 14.01.2021 / 09.12.2019

'Aworth Survey Consultants'
Drawing numbers: 3553-2/5/6/7
Date of creation: 18.12.2009

The application boundary has been derived by title plan and land ownership reports and produced by:
Velocity Transport
Drawing no: 4060-1100-T-023
Produced: Dec 20

Spot levels are defined as AOD and reflected in metres

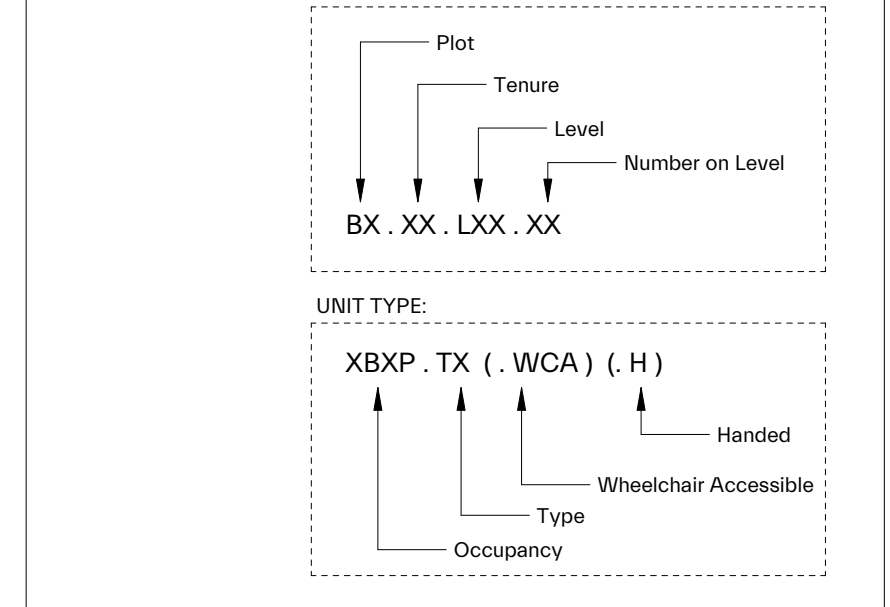

revision	date	amendment
P04	06-09-2023	GLA 2 Stair Planning Addendum
P03	25-03-2022	Planning Revision A
P02	15-10-2021	Planning
P01	01-10-2021	Amendments Pre Planning Submission

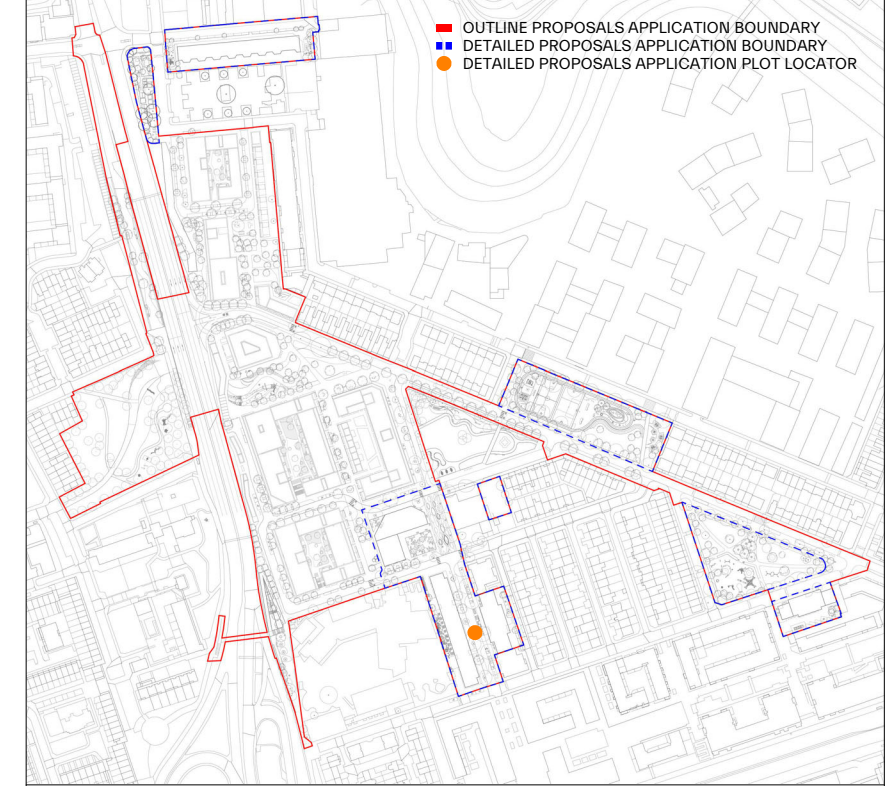
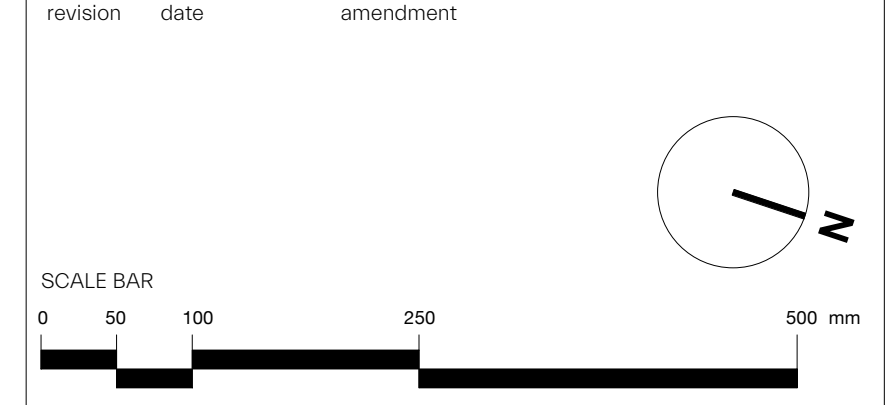

MORRIS+COMPANY
15 Mare Street, London, E8 3QE
Tel: +44 (0)20 7586 7440
www.morrisandcompany.com

- Do not scale from this drawing
- All dimensions to be checked on site by the Contractor
- And such dimensions to be their responsibility
- Report all drawing errors and omissions to the Architect
- All dimensions in millimeters unless noted otherwise
- If in doubt ask Contract Administrator

job title	
Aberfeldy Village	
drawing title /	
PLOT H1/H2 - PROPOSED SR UNIT LAYOUTS	
status	S2 - FOR INFORMATION
scale	As indicated @ A1
project	A303
originator	MCO
zone	BH
level	ZZ
type	DR
role	A
number	06431
revision	P04