



BH3 typical plan (L02-L04)

1 BH PLN 02  
06132 1 : 150

**SUPPLEMENTARY INFORMATION:**  
 These drawings reflect the current position of the scheme development at RIBA Stage 2, they should be read in conjunction with the following information prepared by Morris+Company:  
 - Aberfeldy Village, Phase A, Design and Access Statement  
 Drawings should be read in conjunction with information prepared by other consultants (where applicable):  
 - Landscape Design Drawings (LDA)  
 - Structural Engineers Drawings and Specification (MEINHARDT)  
 - MEP Engineers Drawings and Specification (MEINHARDT)

**EXTENTS AND BOUNDARIES:**  
 These drawings combine survey and site information produced by others and as such should be verified for accuracy.  
 Existing site information, context, surrounding infrastructure, neighboring building extents and plots are derived from 2D Surveys, produced by:  
 'Sumo Services Ltd'  
 Drawing numbers: SOR018502 / SOR018561/ SOR016539  
 Date of creation: 17.12.2020 / 14.01.2021 / 09.12.2019  
 'Aworth Survey Consultants'  
 Drawing numbers: 3553-2/5/6/7  
 Date of creation: 18.12.2009  
 The application boundary has been derived by title plan and land ownership reports and produced by:  
 Velocity Transport  
 Drawing no: 4060-1100-T-023  
 Produced: Dec 20  
 Spot levels are defined as AOD and reflected in metres

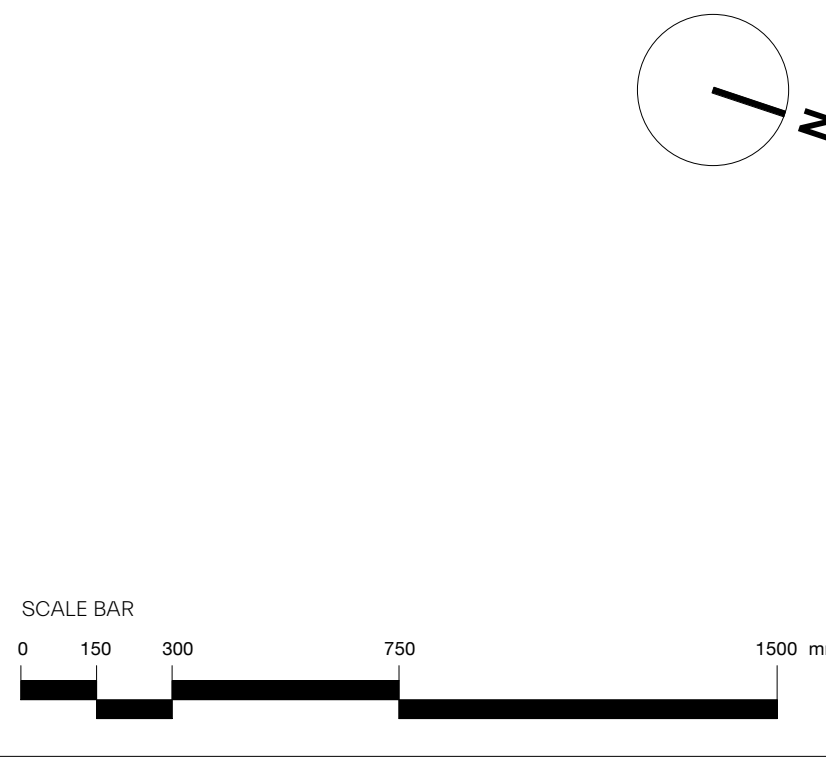
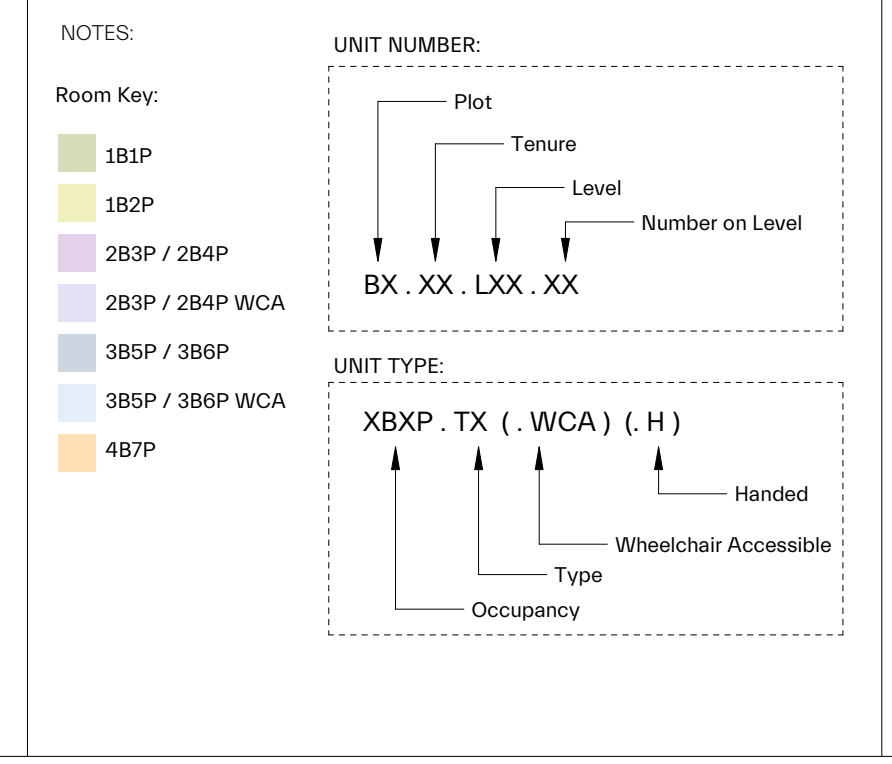

revision	date	amendment
P01	01-10-2021	Amendments Pre Planning Submission
P02	15-10-2021	Planning
P03	25-03-2022	Planning Revision A
P04	09-09-2023	GLA 2 Stair Planning Addendum
P05	19-09-2023	GLA 2 Stair Planning Addendum

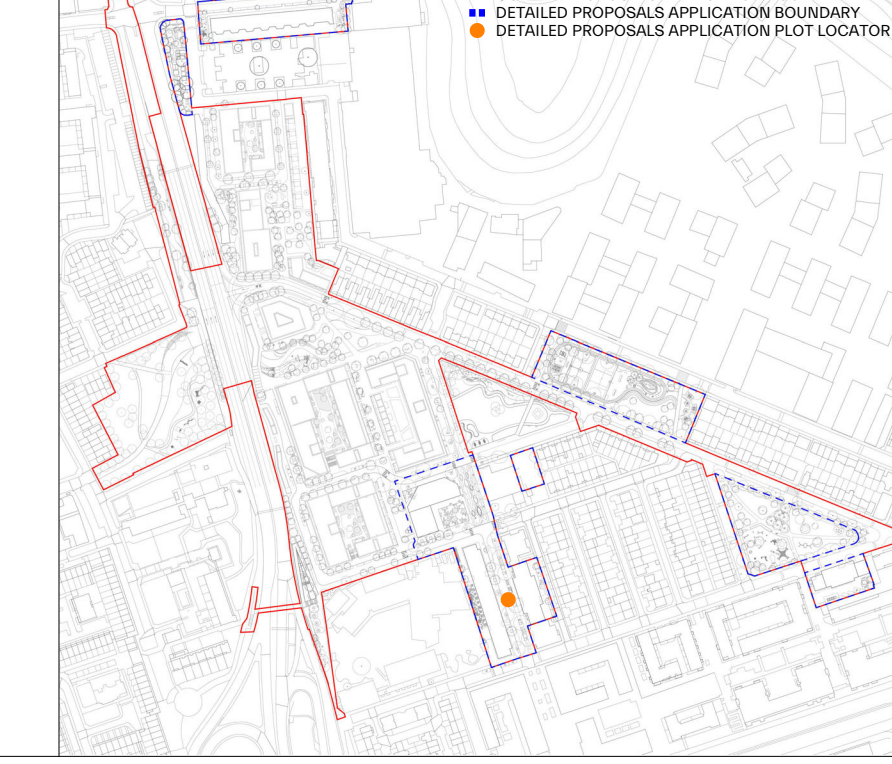

**MORRIS+COMPANY**  
 15 Mare Street, London, E8 3QE  
 Tel: +44 (0)20 7566 7440  
 www.morrisandcompany.com

- Do not scale from this drawing  
 - All dimensions to be checked on site by the Contractor  
 - And such dimensions to be their responsibility  
 - Report all drawing errors and omissions to the Architect  
 - All dimensions in millimeters unless noted otherwise  
 - If in doubt ask Contract Administrator

job title  
**Aberfeldy Village**

drawing title / location  
**PLOT H - PROPOSED SECOND FLOOR PLAN**

status  
**S4 - FOR APPROVAL**

scale  
**As indicated @ A1**

project	originator	zone	level	type	role	number	status - revision
A303	MCO	BH	02	DR	A	06132	P05

© Morris+Company Ltd.