

1 BF PLD 50_2B4P_Type D_L02-06
06412 1 : 50

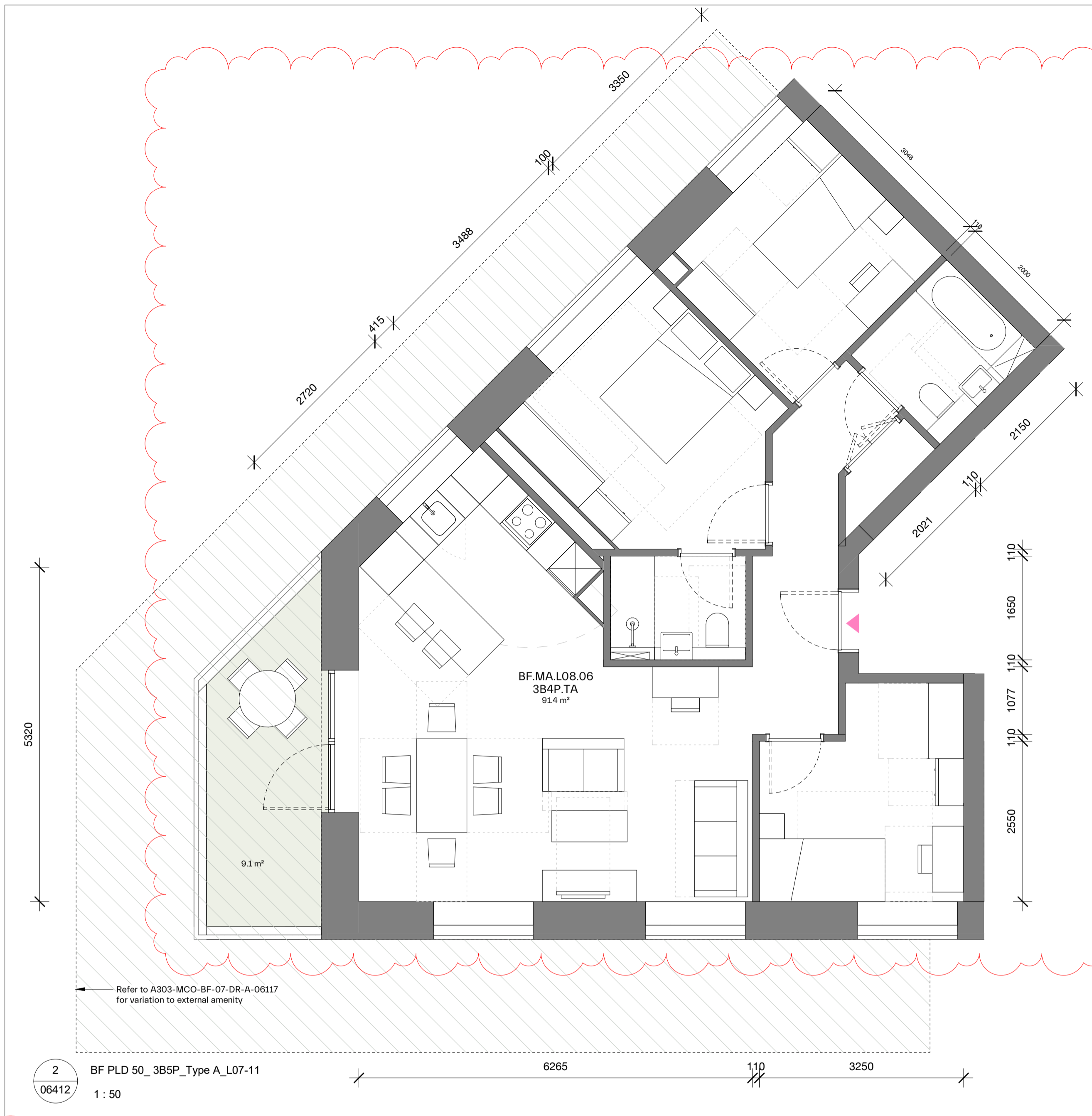

2 BF PLD 50_3B5P_Type A_L07-11
06412 1 : 50

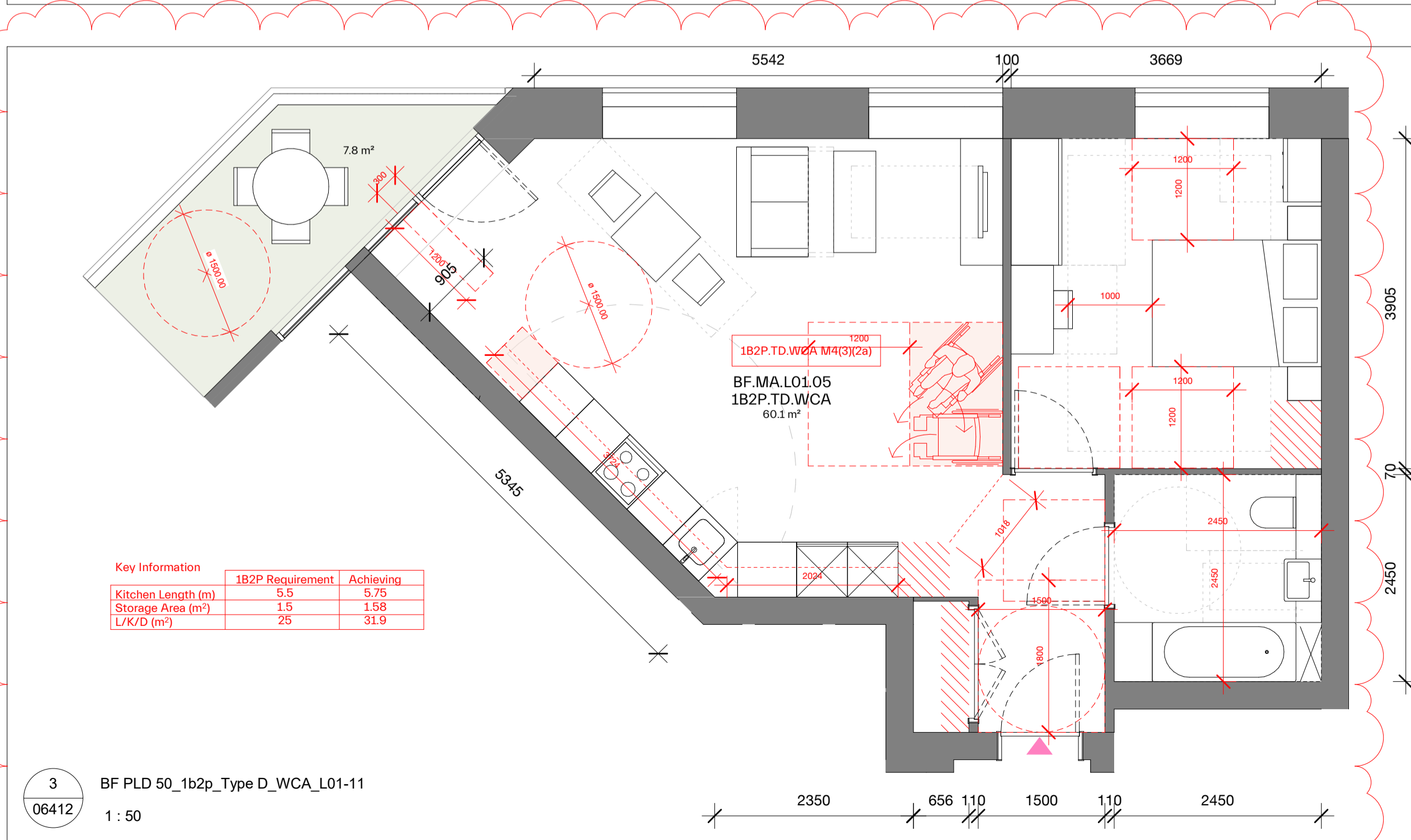

3 BF PLD 50_1b2p_Type D_WCA_L01-11
06412 1 : 50

SUPPLEMENTARY INFORMATION:
These drawings reflect the current position of the scheme development at RIBA Stage 2, they should be read in conjunction with the following information prepared by Morris+Company:
- Aberfeldy Village, Phase A, Design and Access Statement
Drawings should be read in conjunction with information prepared by other consultants (where applicable):
- Landscape Design Drawings (LDA)
- Structural Engineers Drawings and Specification (MEINHARDT)
- MEP Engineers Drawings and Specification (MEINHARDT)

EXTENTS AND BOUNDARIES:
These drawings combine survey and site information produced by others and as such should be verified for accuracy.

Existing site information, context, surrounding infrastructure, neighboring building extents and plots are derived from 2D Surveys, produced by:

'Sumo Services Ltd'
Drawing numbers: SOR018502 / SOR018561/ SOR016539
Date of creation: 17.12.2020 / 14.01.2021 / 09.12.2019
'Aworth Survey Consultants'
Drawing numbers: 3553-2/5/6/7
Date of creation: 18.12.2009

The application boundary has been derived by title plan and land ownership reports and produced by:
Velocity Transport
Drawing no: 4060-1100-T-023
Produced: Dec 20

Spot levels are defined as AOD and reflected in metres

NOTES:

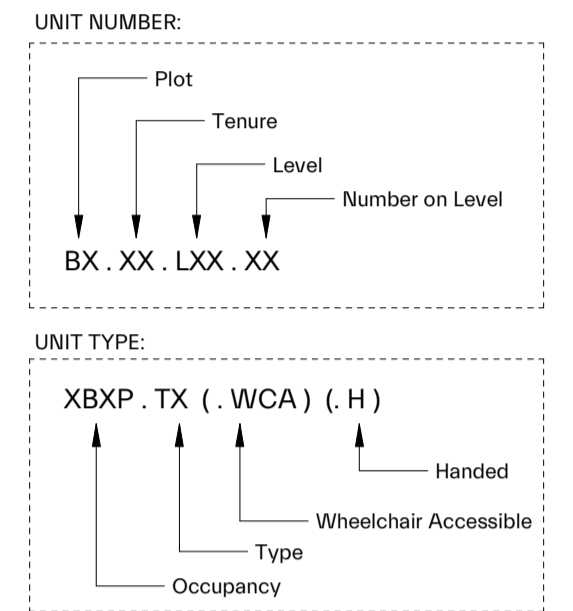

- P06 25-01-2023 Planning Addendum 2 Stair Adjustments
- P05 18-10-2022 GLA Stg. 1 w. Plot F Unit Amendments
- P04 09-09-2022 GLA Stage 1 Fire Adjustments
- P03 25-03-2022 Planning Revision A
- P02 15-10-2021 Planning
- P01 01-10-2021 Amendments Pre Planning Submission

revision date amendment

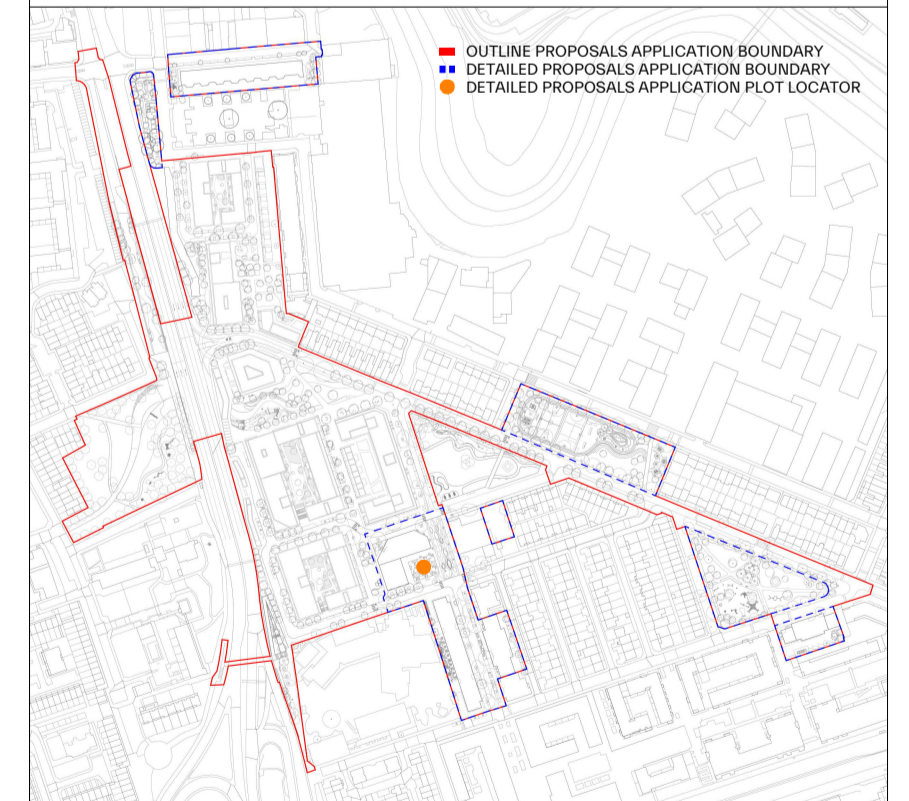
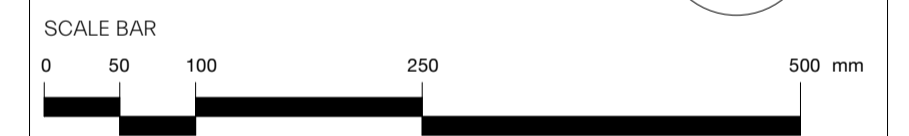
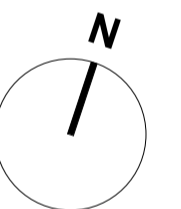

MORRIS+COMPANY

15 Mare Street, London, E8 3GE
Tel: +44 (0)20 7585 7440
www.morrisandcompany

- Do not scale from this drawing
- All dimensions to be checked on site by the Contractor
- And such dimensions to be their responsibility
- Report all drawing errors and omissions to the Architect
- All dimensions in millimeters unless noted otherwise
- If in doubt ask Contract Administrator

job title

Aberfeldy Village

drawing title /

PLOT F - PROPOSED MA UNIT LAYOUTS

status S4 - FOR APPROVAL

scale As indicated @ A1

project	originator	zone	level	type	role	number	revision
A303	MCO	BF	ZZ	DR	A	06412	P06