

N



BASED ON ORDNANCE SURVEY MAPPING AND REPRODUCED BY TRANSPORT PLANNING PRACTICE WITH THE PERMISSION OF THE CONTROLLER OF HMSO © CROWN COPYRIGHT

Based on layout, drawing Z\_Exa\_COORDINATION GF, TPP REF IN\_112.

This drawing has been prepared for planning purposes and should not be used for construction.

Vehicle used

Phoenix 2-20W (with Elite 2 6x2 RS chassis)  
 Overall Length 10.220m  
 Overall Width 3.211m  
 Overall Body Height 2.530m  
 Min Body Ground Clearance 0.416m  
 Track Width 2.530m  
 Lock to Lock Time 4.00s  
 Kerb to Kerb Turning Radius 6.800m

# CHARLTON RIVERSIDE, GREENWICH

## Plot A

### Swept path analysis of 10.2m refuse vehicle

TRANSPORT PLANNING PRACTICE

70 Cowcross Street  
 London, EC1M 6EL

t: 020 7608 0008  
 w: www.tppweb.co.uk

SCALE @ A3 1:500

DATE 12/12/17

DRAWN BY LD

CHECKED CW

DRAWING NUMBER 30821/AC/211  
 REV A

T:\300000\_Projects\30821 Charlton Riverside, Greenwich\ACAD\2017 scheme\209\_A - 212\_A.dwg



BASED ON ORDNANCE SURVEY MAPPING AND REPRODUCED BY TRANSPORT PLANNING PRACTICE WITH THE PERMISSION OF THE CONTROLLER OF HMSO © CROWN COPYRIGHT

Based on layout, drawing Z\_ExA\_COORDINATION GF, TPP REF - IN\_112.

This drawing has been prepared for planning purposes and should not be used for construction.

**Vehicle used**

Phoenix 2-20W (with Elite 2 6x2 RS chassis)

- Overall Length 10.220m
- Overall Width 3.211m
- Overall Body Height 2.530m
- Min Body Ground Clearance 0.416m
- Track Width 2.530m
- Lock to Lock Time 4.00s
- Kerb to Kerb Turning Radius 6.800m

# CHARLTON RIVERSIDE, GREENWICH

## Plot B

### Swept path analysis of 10.2m refuse vehicle

**TRANSPORT PLANNING PRACTICE**

70 Cowcross Street  
London, EC1M 6EL

t: 020 7608 0008  
w: www.tppweb.co.uk

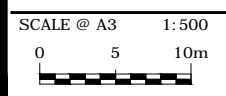

DATE 18/12/17

DRAWN BY LD

CHECKED CW

DRAWING NUMBER 30821/AC/212

REV B

T:\300000\_Projects\30821 Charlton Riverside, Greenwich\ACAD\2017 scheme\209\_B - 212\_B.dwg

T:\30000\_Projects\30821 Charlton Riverside, Greenwich\ACAD\2017 scheme\213\_A.dwg

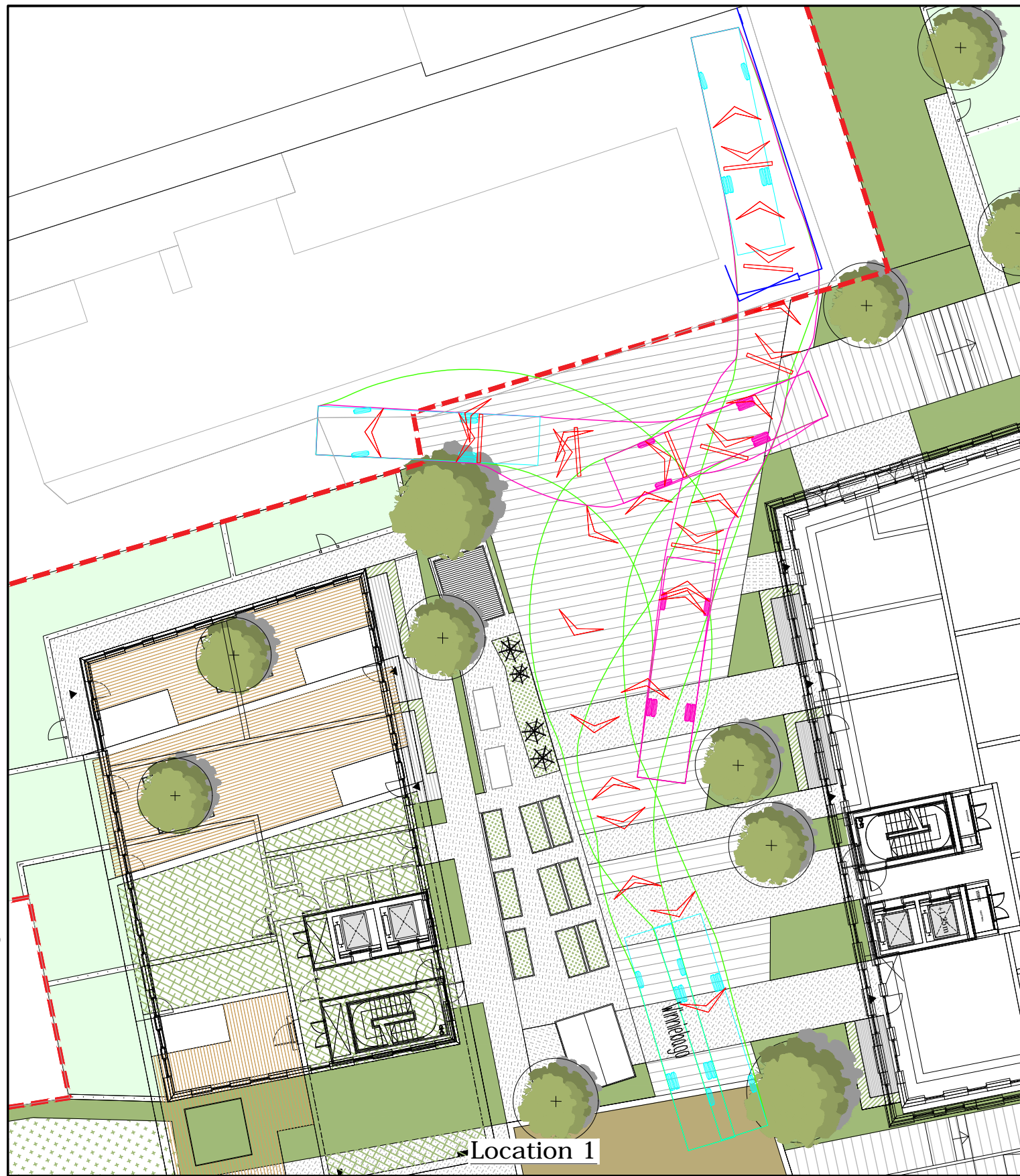

Location 1



Location 2

Vehicle used

Winnieago  
 Overall Length 10.970m  
 Overall Width 2.400m  
 Overall Body Height 2.899m  
 Min Body Ground Clearance 0.370m  
 Track Width 2.400m  
 Lock to Lock Time 4.00s  
 Kerb to Kerb Turning Radius 12.200m

This drawing has been prepared for planning purposes and should not be used for construction. It should be read in conjunction with TPP e-mail of 12/12/17.

BASED ON ORDNANCE SURVEY MAPPING AND REPRODUCED BY TRANSPORT PLANNING PRACTICE WITH THE PERMISSION OF THE CONTROLLER OF HMSO © CROWN COPYRIGHT  
Based on layout, drawing Z\_ExA\_COORDINATION GF. TPP REF - IN\_112.

# CHARLTON RIVERSIDE, GREENWHICH

## Swept path analysis of an RV accessing Amex House

TRANSPORT PLANNING PRACTICE

70 Cowcross Street  
London, EC1M 6EL  
t: 020 7608 0008  
w: www.tppweb.co.uk



SCALE @ A3 1:250	DATE 12/12/17	DRAWN BY LD	CHECKED CW	DRAWING NUMBER 30821/AC/213	REV A
------------------	---------------	-------------	------------	-----------------------------	-------

## **Annex G**

### Framework Travel Plan



# Leopard Guernsey Anchor Propco Ltd

Anchor and Hope Lane Sites  
Framework Travel Plan

**30821/D009d**  
**December 2017**



**Contents**

1 Introduction..... 1

2 Site Assessment..... 4

3 Travel Plan Aims and Objectives ..... 11

4 Travel Plan Management ..... 12

5 Travel Plan Measures for Residents ..... 14

6 Travel Plan Measures For Commercial Employees ..... 18

7 Travel Surveys..... 22

8 Targets and Monitoring..... 23

9 Action Plan ..... 26

**Tables**

Table 2.1 – Summary of Bus Routes (Hourly Frequency in Each Direction)..... 6

Table 7.1 – Indicative travel mode split..... 22

Table 8.1 – Proposed residential targets by mode ..... 23

Table 9.1 – Residential Action Plan ..... 27

Table 9.2- Commercial Action Plan..... 28

**Appendices**

Appendix A ATTrBuTe Test

Transport Planning Practice  
 70 Cowcross Street  
 London  
 EC1M 6EL  
 020 7608 0008  
 email@tppweb.co.uk  
 www.tppweb.co.uk



# 1 INTRODUCTION

1.1.1 Transport Planning Practice (TPP) has been appointed by Leopard Guernsey Anchor Propco Ltd to provide transport advice in relation to the proposed redevelopment of the VIP Trading Estate and the VIP Industrial Estate site located on Anchor and Hope Lane within the Royal Borough of Greenwich (RBG).

1.1.2 The site is located within the Charlton Riverside SPD Area between Woolwich Road (A206) and the southern bank of the River Thames. The main access to the site is from Anchor and Hope Lane which runs between Woolwich Road and **Bugsby's Way**. The site consists of two main development plots with a narrow strip connecting to Anchor and Hope Lane to the west and another to the north towards the Thames Path. The site location is shown in Figure 1.1.

**Figure 1.1 – Site location**

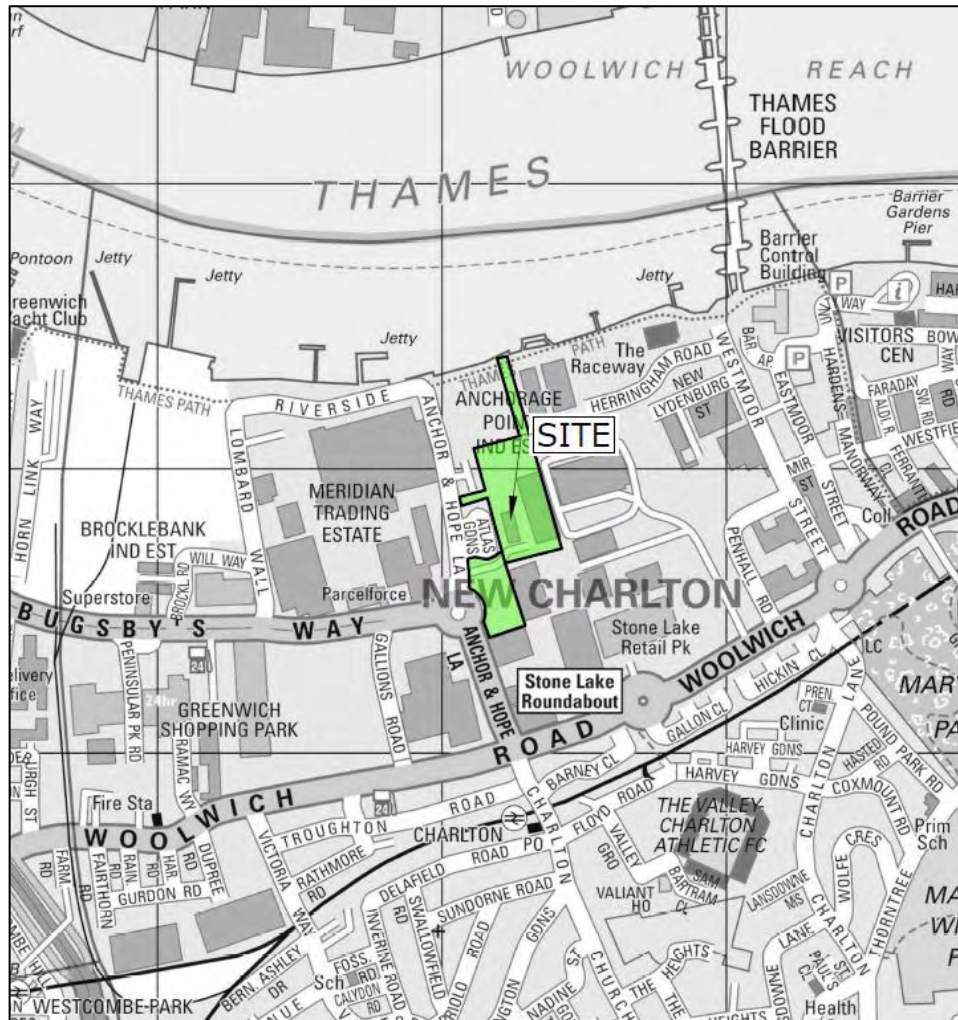

1.1.3 This document is a Framework Travel Plan (FTP). The purpose of this Travel Plan is to set out a strategy for minimising resident's and workplace **occupier's** dependence on travel by private car and for maximising the use of public transport, walking and cycling. Its objective is to promote sustainable modes of travel, which reflects current Government policy objectives in respect of transport.

## **1.2 Context**

1.2.1 The proposed development will provide 771 units residential as well as commercial space (A1-A3/B1/D1/D2). The opening year is expected to be 2023.

1.2.2 The scheme will provide the following:

- 771 residential units, including extensive private gardens and roof terraces;
- 3,236 sqm of flexible commercial space;
- Ancillary residential facilities totalling 496 sqm; and
- 337 sqm of community uses.

1.2.3 This FTP has been produced in accordance with TfL's guidance on Travel Plans (<https://tfl.gov.uk/info-for/urban-planning-and-construction/travel-plans>). The remaining chapters within this report are outlined below:

- **Section 2: Site assessment** – describes the accessibility of the site by a range of different transport modes.
- **Section 3: Travel Plan Aims and Objectives** - sets out the aims and objectives of this Travel Plan.
- **Section 4: Travel Plan Management** - outlines how travel planning for the site will be managed by the Sustainable Travel Manager and Travel Plan Co-ordinators and how the Travel Plan will be secured.
- **Section 5 & 6: Travel Plan Measures for Residents and Staff** - sets out the proposed measures to encourage future residents and staff to travel using sustainable modes.
- **Section 7: Travel Surveys** – sets out the proposed modal split for the residential and commercial aspects of the Anchor and Hope Lane sites.

- **Section 8: Targets and Monitoring** - outlines the method for setting targets and monitoring the progress of the Travel Plan.
- **Section 9: Action Plan** - provides an Action Plan for implementing the Travel Plan.

## **2 SITE ASSESSMENT**

### **2.1 Site location**

2.1.1 The site sits within a currently predominately industrial area located between Woolwich Road (A206) and the southern bank of the River Thames. The main access to the site is from Anchor and Hope Lane which runs between Woolwich Road and Bugsby's Way. **Figure 1.1** shows the location of the site.

2.1.2 With the exception of two residential areas known as Atlas Gardens and Derrick Gardens the site is surrounded by industrial uses. The site forms part of the wider Charlton Riverside SPD Area for substantial residential/mixed-used redevelopment **as set out in the mayor's 'City in the East' document and RBG's** Charlton Riverside SPD dated June 2017.

### **2.2 Site access**

2.2.1 The main pedestrian desire lines from the development to public transport services would be towards Charlton Station and bus stops on Anchor and Hope Lane, Bugsby's Way and Woolwich Road. **Other key routes would be west towards the retail units off Bugsby's Way** to the west of the site and to the north towards the Thames Walkway.

2.2.2 The development has been designed to be highly permeable in terms of access for pedestrians and cyclists. As well as the main vehicular access to the site from Anchor and Hope Lane, two additional pedestrian and cycle routes will be provided:

- Anchor and Hope Lane, to the north of the existing site access – This has been designed to also allow for secondary means of access for emergency vehicles.
- To the Thames Path to the north - This route would provide direct access to pedestrian and cycle connections along the south of the river Thames.

2.2.3 There are currently no crossing points provided by the Anchor and Hope Lane / **Bugsby's Way roundabout which would allow access to the western side of** Anchor and Hope Lane (south of Bugsby's Way) where there is an existing bus stop for northbound services.

2.2.4 To improve pedestrian connection to and from the site, a Toucan crossing is proposed on Anchor and Hope Lane to the south of the Bugsby's Way

roundabout. This takes into account the bus lane and the location of trees on both side of Anchor and Hope Lane. The design also improves access for cyclists and the existing bus lane can also be used by cyclists.

- 2.2.5 Vehicular access to the site is provided from an improved existing access on Anchor and Hope Lane.

## **2.3 Public Transport**

- 2.3.1 The site is within walking distance of five bus services and Charlton Railway Station. The existing site ranges from PTAL 4 in the southern end to PTAL 3 at the north end, with an average PTAL across the site of 4 which indicates good accessibility. This has been agreed with TfL.
- 2.3.2 However, it should be noted that future public transport improvements associated with the Charlton Riverside Masterplan SPD would be expected to result in the future PTAL of the site increasing to Level 5.

## **2.4 Bus**

- 2.4.1 The nearest bus stop to the site is on the northern side of Bugsby Way, to the west of the roundabout with Anchor and Hope Lane (85m from the site boundary). This bus stop is served by bus routes 472 and 486 travelling south on Anchor and Hope Lane towards Queen Elizabeth Hospital or Woolwich. For services in the opposite direction, there are bus stops on the western side of Anchor and Hope Lane (170m) and on the southern site of Bugsby Way (250m).
- 2.4.2 Three additional bus routes (161, 177 and 180) are available on Woolwich Road. The nearest set of bus stops is located to the east of the junction with Anchor and Hope Lane, approximately 330m (a 3 to 4 minute walk) from the site.
- 2.4.3 A summary of the existing bus services are provided in Table 2.1.

**Table 2.1 – Summary of Bus Routes (Hourly Frequency in Each Direction)**

<b>Bus route</b>	<b>Route</b>	<b>AM peak</b>	<b>PM peak</b>	<b>Sat</b>	<b>Sun</b>
472	North Greenwich – Bugsby Way – Woolwich – Thamesmead	9	9	8	6
486	North Greenwich – Bugsby Way – Charlton – Eltham – Welling – Bexleyheath	7	7	7	5
161	North Greenwich – Woolwich Road – Woolwich – Eltham – Chislehurst	6	6	5	5
177	Peckham – Greenwich – Woolwich Road – Woolwich – Thamesmead	6	6	5	5
180	Lewisham – Greenwich – Woolwich Road – Woolwich – Abbey Wood – Belvedere	6	6	6	4
	<b>Total</b>	<b>34</b>	<b>34</b>	<b>31</b>	<b>25</b>

2.4.4 The above shows that there are up to 34 buses per hour in each direction accessible from the site. This is on average one bus every two minutes in each direction.

2.4.5 In addition to the above services, the Woolwich Road bus stops are served by night bus N1 which operates between Thamesmead and Central London, with a frequency of 2 to 3 buses per hour in each direction.

## **2.5 National rail**

2.5.1 Charlton Railway Station is located approximately 350m (a 3 to 4 minute walk) south of the site. Trains serving this station run between London and Kent and are operated by Southeastern. There are around 8 trains per hour in each direction during weekday peak times.

2.5.2 The journey time to London Cannon Street is 24 minutes and to London Charing Cross is 33 minutes.

2.5.3 Construction is currently underway for Crossrail which will provide a direct rail **connection between all of London’s main business centres, linking Heathrow, with Paddington, the West End, the City and Canary Wharf.**

2.5.4 The nearest Crossrail station to the site will be Woolwich, approximately 3km from the site. Woolwich Station can be accessed from the site using local bus services or rail services, with interchange at Woolwich, from Charlton. Crossrail services on this section of the route are expected to operate in 2018, prior to the opening of the proposed development in 2023 with a service frequency of 12 trains per hour in each direction.

2.5.5 Crossrail is expected to significantly reduce journey times between Woolwich Station and destinations in central London, it is expected to take 8 minutes to Canary Wharf, 14 minutes to Liverpool Street and 22 minutes to Bond Street.

## **2.6 River Services**

2.6.1 The nearest river service to the site is North Greenwich Pier which is located approximately 1.5 miles to the north west of the site. Bus routes 472 and 486, accessed from Anchor and Hope Lane Stop G, provide services to North Greenwich, the Pier is within a short walk of the bus stops.

2.6.2 North Greenwich Pier is served by river boat services one (RB1) and five (RB5). RB1 provides services east and west along the River Thames terminating at Woolwich Arsenal Pier and London Eye Pier respectively. RB1 operates at approximately three services per hour and serves key destinations including Canary Wharf Pier, London Bridge City Pier, Blackfriars Pier and Embankment Pier. RB5 runs between North Greenwich Pier and Woolwich Arsenal Pier only, operating between 1200 and 1700 at approximately two services per hour.

2.6.3 The Charlton Riverside SPD identifies the northern end of the Anchor and Hope Lane as a future riverside pier which would be anticipated to be operational once sufficient regeneration of the area is undertaken. This would provide direct links to the Riverboat services, likely to be an additional stop for RB5.

## **2.7 Walking**

2.7.1 The most important pedestrian desire lines to a site are considered to be those which provide access to public transport services and local facilities. Within the vicinity of the site, public transport services are located to the south of the site and **Greenwich Shopping Park is located to the west on Bugsby's Way.**

2.7.2 **The main access to the site is from Anchor and Hope Lane from the site's western edge.** Footways, dropped kerbs and tactile paving are provided along **Anchor and Hope Lane. At the roundabout with Bugsby's Way to the south of the site,** uncontrolled crossing facilities are provided on one of the arms (the northern Anchor and Hope Lane arm).

2.7.3 Signal controlled pedestrian crossings are provided at the Anchor and Hope Lane / **Woolwich Road junction and Bugsby's Way / Gallions Road junction.**

## 2.8 Cycling

2.8.1 The local area is generally flat which helps to make cycling attractive as a mode of transport. Designated cycle routes are provided within close proximity of the site, which connects to the wider network across London. Figure 2.1 shows the local cycle network.

**Figure 2.1 – Local Cycle Network**

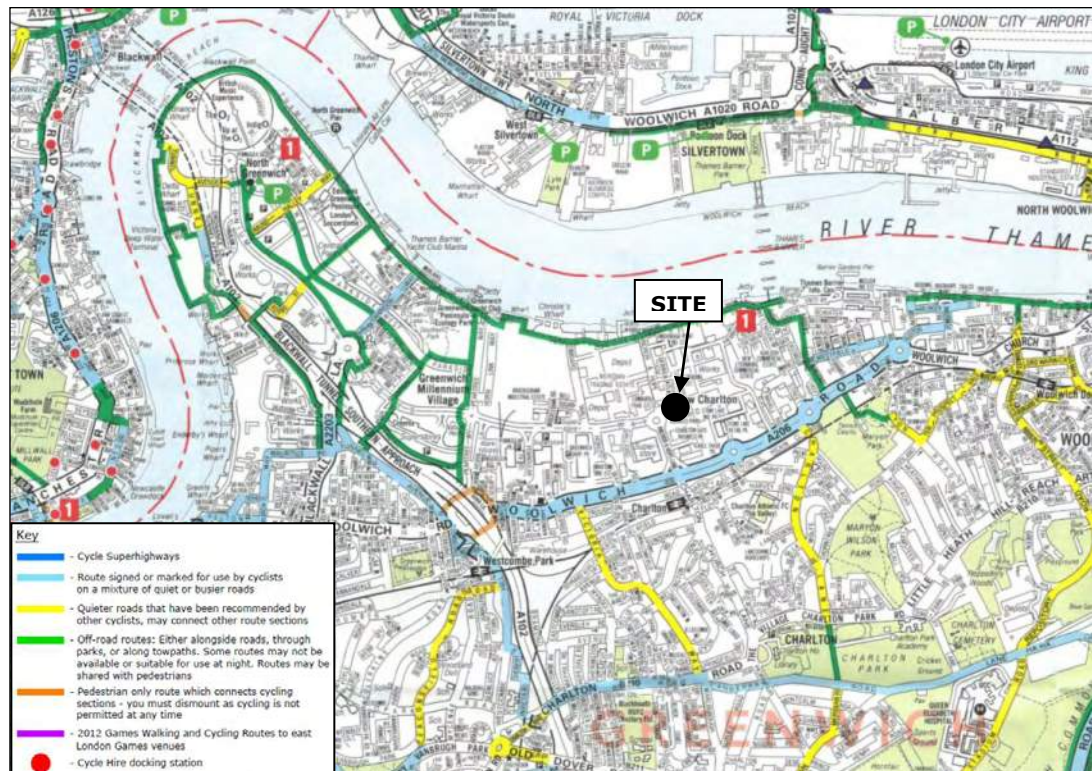

2.8.2 The A206 Woolwich Road to the south of the site is a signed cycle route with marked on-street cycle routes in both directions. The Thames Path is located to the north of the site and forms part of the National Cycle Network (NCN) Route 1. This is an off-road route which provides access to North Greenwich to the northwest and towards Royal Arsenal to the east.

2.8.3 These cycle routes can be accessed from Anchor and Hope Lane. These provide good access to and from local residential areas and other local facilities. The local routes have adequate street lighting and signage to various local destinations.

## 2.9 Highway Network

2.9.1 Site access is provided off Anchor and Hope Lane, via a private access road which can provide for two-way vehicle movements. It also Ropery Business Park

- 2.9.2 Anchor and Hope Lane is a wide, two-way carriageway, with sections of marked on-street parking on both sides. It meets Bugsby's Way to the south at a roundabout and continues south towards a signal controlled junction with the A206 Woolwich Road.
- 2.9.3 Bugsby's Way has two lanes in each direction and provides access to the west to Greenwich Shopping Park, Millennium Leisure Park, The O<sub>2</sub> as well as the Blackwall Tunnel. The A206 Woolwich Road is aligned approximately east-west. It provides access to Woolwich to the east and the Greenwich Market to the west. It also provides an alternative route to the A102 Blackwall Tunnel Southern Approach.
- 2.9.4 There is a dedicated, segregated southbound bus lane on Anchor and Hope Lane to the south of the roundabout with Bugsby's Way. There are also other bus priority measures in the local area.
- 2.9.5 Uncontrolled, marked on-street parking bays are provided on both sides of Anchor and Hope Lane to the north of the site. There is no on-street parking to the south on Anchor and Hope Lane or Bugsby's Way.

## **2.10 Car Parking**

- 2.10.1 The proposed development will provide 209 car parking spaces for the residential use. This is equivalent to 0.27 space per dwelling which is in accordance with the London Plan standards. The commercial use will be allocated one Blue Badge Holder bay and no other general car parking provision.
- 2.10.2 At least 10% of the residential parking provision will be suitable for use as accessible bays which meets **the Borough's planning policy, subject to** appropriate management of the car parking provision to allow for re-allocation of bays with priority given to car owning blue badge holder residents.
- 2.10.3 As a minimum, 20% of all spaces will have electric vehicle charging points and a further 20% will have a passive provision as required by RBG and GLA.

## **2.11 Car club**

- 2.11.1 Car Clubs provide an easily accessible vehicle to members for short term hire as and when needed. This provides a lower fixed cost alternative to car ownership and private car use.
- 2.11.2 There are two Car Club vehicles located to the south of Charlton Station, approximately 550m (a 5 to 7 minute walk) from the site on Sundorne Road.

The next nearest Car Club vehicles are located on Peartree Way (1.1km from the site, 2 vehicles) and on Fairthorn Road (1.2m from the site, 2 vehicles). These additional vehicles are operated by Zipcar.

- 2.11.3 It is expected that there will be an overall Car Club strategy across the Charlton Riverside SPD area. This would maximise the number of residents within walking distance of the future vehicles and ensure the success and financial viability of the Car Club. The applicant will support RBG in promoting Car Club use as part of this FTP.

### **3 TRAVEL PLAN AIMS AND OBJECTIVES**

3.1.1 This section outlines the proposed aims and objectives of the Travel Plan which will be used to set the targets.

#### **3.2 Aims**

3.2.1 The aim of this Travel Plan is to:

*'Create a sustainable, community driven environment for all occupants of the development which promotes a range of lifestyle and travel choices and reduces reliance on the private car.'*

#### **3.3 Objectives**

3.3.1 Objectives are the high-level aims of the Travel Plan. They help to give the Travel Plan direction and provide a focus. The main objectives of this Travel Plan are set out below in the context of current, relevant guidance on Travel Plans:

- Achieve and maintain the predicted sustainable travel patterns to and from the development and increase the sustainable travel mode share.
- Encourage residents to consider altering their travel choices and move up within the sustainable transport hierarchy (e.g. from public transport to walking or cycling).
- Encourage employees to make well-informed and sustainable decisions about the way they travel to and from the development.
- Ensure residents and employees are aware of the range of travel choices available to them and address needs for access to a full range of facilities and services – for health, leisure, recreation and shopping.
- Promote healthy lifestyles and sustainable, vibrant local communities by promoting the health benefits of walking and cycling, and raising awareness on the impacts of transport modes on the environment.
- Monitor travel patterns and identify opportunities to encourage travel by walking and cycling.

## **4 TRAVEL PLAN MANAGEMENT**

4.1.1 This section sets out how the travel planning will be managed by the Sustainable Travel Manager (STM) and Travel Plan Co-ordinators (TPCs). It also sets out how the Travel Plan will be secured.

### **4.2 Sustainable Travel Manager**

4.2.1 A Sustainable Travel Manager (STM) will be appointed to take responsibility for the development and management of the Travel Plan and act as the site-wide Travel Plan Co-ordinator. The STM role for the site will be fulfilled by an appointed consultant or the site management company. It will be the responsibility of the developer to ensure that a STM is appointed prior to the first occupation of the site. The roles and responsibilities of the STM are set out below:

- Ensuring the structures for the ongoing management of the Travel Plan are set up and running effectively;
- Liaising with public transport operators and other service providers such as car club operators.
- Overseeing the monitoring and reporting of the Travel Plan including liaising with the Local Authority where appropriate.
- Overseeing and monitoring the regular surveys and questionnaires, which will inform the ongoing development of the Travel Plan.
- Monitoring and where necessary updating Travel Plan targets.
- Administration of the Travel Plan, involving the maintenance of necessary systems, data and paperwork, consultation and promotion. These duties continue for the duration of the Travel Plan.
- Liaison with the TPCs who will assist in the day to day interface with occupants of the proposed development in facilitating the Travel Plan.

### **4.3 Travel Plan Co-ordinators**

4.3.1 To ensure that there is site wide adoption of the Travel Plan, the STM may be assisted in delivering the measures by TPCs. The STM will liaise with the TPCs, as necessary, to jointly promote the Travel Plan. Commercial occupants may also appoint their own TPCs. The TPC role will involve:

- Giving a **'human face' to the Travel Plan** – explaining its purpose and the transport opportunities available. Implementing any additional measures.

- Giving advice and information on transport-related issues to residents, employees and visitors.
- On-site coordination of data collection for the Travel Plan.
- Helping establish and promote the individual measures in the Travel Plan.
- Providing on-site support to the STM, as required.

#### **4.4 Securing the Travel Plan and funding**

- 4.4.1 The Travel Plan would be expected to be secured through condition or S106 obligation.
- 4.4.2 The specification of residential and commercial targets will be set within 1 month following the initial baseline travel surveys, i.e. upon 75% occupation.
- 4.4.3 All measures implemented prior to the development being occupied will be funded by the developer, including the appointment of the STM and the production of marketing material. The developer will fund the ongoing monitoring travel survey.

## **5 TRAVEL PLAN MEASURES FOR RESIDENTS**

5.1.1 This section sets out a range of measures that are proposed for the development it describes a number of initiatives proposed with a focus on ensuring that residents are made aware of all sustainable travel options available to them.

### **5.2 Travel Information Pack**

5.2.1 A Travel Information Pack containing travel information will be provided to each household on or before they move into the new development. Providing this information in advance ensures that residents become aware of the various modes of transport and existing services that are available to them at the earliest opportunity.

5.2.2 The packs will include the following:

- an explanation of the Travel Plan, its purpose, aims and objectives;
- contact details for the operation of the Travel Plan;
- information on the health benefits of walking and information on how to plan walking routes;
- TfL cycle network maps relevant to Greenwich and information on the cycle tools in TfL journey planner;
- information on cycle training available to people living, working or studying in Greenwich;
- details on car clubs in the area;
- information on travel planning website services such as TfL and Citymapper journey planners, which also include access to real time information, to raise awareness of transport options and alternatives in case of delays or cancellations; and
- information on train and bus service maps and timetables, including late night travel advice.

### **5.3 Initiatives to encourage walking**

5.3.1 To further encourage walking as a main mode of transport for local trips, the following measures could be implemented by the STM / TPCs:

### ***Promotional material***

- 5.3.2 Walking will be promoted within the Travel Packs which will be issued to residents. This could include the health benefits of walking and highlight the network of walking routes in the local area.

### ***Walking events***

- 5.3.3 The Travel Information Packs will provide information on walking events and could also promote the Greenwich Get Walking programme where weekly walks are available, led by local volunteers or health trainers. Further information and walk timings can be found at: [www.walkingforhealth.org.uk](http://www.walkingforhealth.org.uk)

## **5.4 Initiative to encourage cycling**

### ***Cycle parking***

- 5.4.1 Secure cycle parking is provided for residents. All the long stay cycle parking will be provided in secure cycle stores at ground and basement level on both plots.
- 5.4.1 Visitor cycle parking will be provided in the form of Sheffield stands at ground level located within the public realm. The usage of cycle parking will be monitored as part of the overall Travel Plan monitoring strategy on the site.

### ***Cycle maps and routes***

- 5.4.2 Cycle information, including cycle maps showing key routes and other facilities such as local cycle parking locations and cycle shops, would be provided in the Travel Packs. Cycle route maps for Greenwich are available via the Greenwich Get Active website and for London wide routes they are available from: [www.tfl.gov.uk/modes/cycling/routes-and-maps](http://www.tfl.gov.uk/modes/cycling/routes-and-maps).

### ***Cycle training***

- 5.4.3 RBG offer free cycle training to anyone who works, studies or lives in the borough over the age of seven. The sessions take place in different locations around the borough. Participants can borrow bikes for free as well as helmets and high vis vests. The scheme offers three grades of one-to-one courses and group training courses. This helps them to understand and cycle the safest and most convenient route. These cycle training sessions would be promoted by the Travel Information Pack.

### ***Bike maintenance courses***

- 5.4.4 Bike maintenance courses are available at Charlton Athletic Football Stadium. Courses cost £10 per person and you need to bring your own bike.

### ***Bicycle user Groups (BUG's)***

- 5.4.5 The TPC will encourage the creation of a site wide BUG for residents and other occupiers providing the opportunity for cyclists to meet informally and discuss cycling related issues, such as safe cycle routes within the surrounding area.

### ***Membership to the London Cycling Campaign (LCC)***

- 5.4.6 LCC is a cyclists' organisation with local groups throughout London. Local LCC groups promote cycling locally, improve conditions for cyclists in their borough and organise leisure rides and social events and provide support for cyclists. The benefits on offer to LCC members include discounts at over 115 bike shops in London; exclusive cycle theft insurance packages; free third party insurance for damage or injury up to the value of £1 million; access to local LCC borough groups; and free legal advice. Membership could be promoted by the STM / TPCs and the details of the local LCC group together with membership information will be included within the Travel Packs.

## **5.5 Initiatives to reduce car use**

- 5.5.1 The site is well located to take advantage of the good provision of public transport, whilst also having on-site amenities. The following measures will also be considered to reduce car use.

### ***Low car parking provision***

- 5.5.2 The Anchor and Hope Lane sites will provide car parking at an overall ratio of approximately 0.27 spaces per dwelling. The provision will meet the expected demand whilst also encouraging lower levels of car dependency and the use of sustainable travel choices.

### ***Car clubs***

- 5.5.3 Information on Car Club membership will be provided to residents along with current locations of car club bays. This means it is possible to not own a car but still have the ability to access the use of a car for essential journeys.

### ***Electric vehicle charging points***

- 5.5.4 Electric car charging points will be available within the development. A minimum provision of 20% of car parking bays will be fitted with electric vehicle charging points (EVCP). A further 20% of spaces will have a passive EVCP provisions enabling additional future electric car charging facilities to be provided if required.

### ***Single trip deliveries***

- 5.5.5 The site management will provide a facility to allow deliveries of small items to be made during the day and even when residents are not at home. The concierge will be responsible for signing for deliveries and storing packages in secure locations until they are picked up and signed for by the intended recipient. This service will therefore contribute to reduce the number of repeat deliveries to the development.

### ***Provision of internet access at homes***

- 5.5.6 All residential units within the development will have internet access, prior to occupation, providing residents with the opportunity to sign up to an internet provider. This enables residents to consider working from home, undertake web based shopping and provide access to travel information.

### ***Initiatives to encourage the use of public transport***

- 5.5.7 Future residents will be made aware of the full range of buses, national rail, docklands light railway and underground services available to them through the following measures:

#### ***Promotional material***

- 5.5.8 Public transport information, such as access to route maps, timetables and fares, will be included in the Travel Packs.

#### ***Journey planners***

- 5.5.9 Links to the TfL and National Rail journey planners, live bus stop tracking websites and smartphone applications will be promoted within the Travel Packs.

#### ***Real time travel information***

- 5.5.10 Real time information is easily accessible for all public transport from TfL websites and mobile phone apps. These allow residents to tailor the information that they receive to the journeys they are making.

## **6 TRAVEL PLAN MEASURES FOR COMMERCIAL EMPLOYEES**

### **6.1 Introduction**

6.1.1 Commercial occupiers will be encouraged to include the range of Travel Plan measures which are outlined in this chapter. The STM will work with individual TPCs to ensure that the overall Travel Plan objectives for the site have been considered.

### **6.2 Provision of travel information**

6.2.1 Informing future employees of the range of travel choices available to them as well as the Travel Plan measures which will be implemented at the development will be key to the success of the Travel Plan. The ways in which travel information would be provided are set out below.

#### ***Travel Pack***

6.2.2 The workplace tenants will be provided with a Travel Information Pack upon occupation. Electronic versions of the travel information would also be made available. The Travel Pack will contain information on travel and the facilities within the development and could contain the following information:

- Provides an explanation of the Travel Plan, its purpose, aims and objectives and measures;
- contact details for the operation of the Travel Plan;
- information on the health benefits of walking and cycling;
- **information on planning journey's on foot;**
- TfL cycle network maps of the local area and information on the cycle tools in TfL journey planner;
- promotional material setting out the benefits of cycling and information on free adult cycle training from RBG;
- information and location of local car clubs;
- bus network maps and timetable information availability;
- rail network maps and timetables that are available; and
- links to TfL journey planner website and national rail website which provides journey planning and live departure information.

### ***Internet***

- 6.2.3 Information on travel planning website services such as TfL and Citymapper journey planners, to raise awareness of transport options, and alternatives in case of delays or cancellations. TfL journey planner: <http://www.tfl.gov.uk/plan-a-journey/>

### ***Website***

- 6.2.4 The occupiers of the commercial units could provide information on the location of the nearest transport links, including local buses and stations, cycling routes and Car Club bays on their own company website. Information on the purpose of the Travel Plan could also be provided along with the strategies and measures implemented. This would encourage visitors, new members of staff (and potentially interviewees seeking employment) to use sustainable modes of transport.

## **6.3 Increasing walking**

- 6.3.1 To further encourage walking as a main mode of transport for staff, the following measures could be implemented:

### ***Promotional material***

- 6.3.2 Walking will be promoted within the Travel Information Packs which will be issued to tenants. This could include the health benefits of walking and highlight the network of walking routes in the local area.

## **6.4 Increasing cycling**

- 6.4.1 The proposed development will include cycle parking facilities and cycle information will be provided in the Travel Information Packs. The Travel Plan measures to encourage cycling are set out below:

### ***Cycle parking***

- 6.4.2 Separate cycle parking will be provided by commercial operators within their demise for the use of staff of the commercial space. Visitor cycle parking will be provided in the form of Sheffield stands at ground level, located within the public realm.

### ***Cycle maps and routes***

- 6.4.3 Cycle information, including cycle maps showing key routes would be provided in the Travel Packs and could also be provided on the **commercial tenant's website**.

### ***Bikes4Work scheme***

- 6.4.4 The feasibility of providing interest free loans to purchase a bicycle tax free to staff should be explored by the commercial tenants.

### ***Bicycle User Group (BUG)***

- 6.4.5 Workplace BUG's support staff who cycle to and from work by setting up meetings to discuss cycle facility requirements at the workplace and organise events. BUG's are designed to encourage the uptake of cycling for employees.

### ***Cycle training***

- 6.4.6 RBG offer free adult cycle training to anyone who works, studies or lives in the borough. This helps occupiers to cycle the safest and most convenient routes.

## **6.5 Encouraging use of public transport**

- 6.5.1 Commercial tenants will be made aware of the full range of bus services, national rail and underground services available to them through the following measures:

### ***Promotional material***

- 6.5.2 Access to public transport information, such as route maps, timetables and fares, will be included in the Travel Packs.

### ***Journey planners***

- 6.5.3 Links to the TfL and National Rail journey planners, live bus stop tracking websites and smartphone applications will be promoted within the Travel Packs.

### ***Real time travel information***

- 6.5.4 Real time information is easily accessible for all public transport from TfL websites and mobile phone apps. These allow residents to tailor the information that they receive to the journeys they are making.

### ***Season Ticket loan***

- 6.5.5 The feasibility of providing employees with interest free loans to purchase season tickets should be explored by commercial tenants. The loan is then payed back through the employee's salary.

## **6.6 Reducing vehicle trips**

### ***Low car parking provision***

- 6.6.1 One accessible car parking bay is provided for the commercial uses on the site. No general car parking for staff or visitors is provided. The restricted parking

provision will encourage the use of alternative more environmentally friendly modes.

## **6.1 Promotion of sustainable practices for deliveries**

6.1.1 The baseline survey will collect information on the delivery patterns and the TPC will advise the occupiers about the following measures that could be implemented to make the servicing operations more sustainable:

### ***Consolidating deliveries***

6.1.2 Discussing the feasibility of consolidating deliveries which would involve combining and reducing the number of vehicle trips with the delivery operators.

### ***Green vehicles***

6.1.3 Use of hybrid, electric and other low carbon emission vehicles that are less harmful to the environment. Encouraging the use of delivery and collection companies which use green vehicles.

## 7 TRAVEL SURVEYS

7.1.1 This chapter sets out the proposed mode share for the Anchor and Hope Lane sites allowing targets to be set.

### 7.2 Indicative mode share

7.2.1 The development has not been built, therefore the indicative residential and workplace employee modal split is set out below in Table 7.1. The modal split has been derived from the **2011 Census data for the 'Method of Travel to Work'** for the LSOA of Greenwich 004B for the residential mode split and MSOA Greenwich 004 for the Workplace mode split, further workings of the mode share calculations is provided within the Anchor and Hope Lane sites Transport Assessment which has been submitted alongside this FTP. As such the agreed mitigation for the development was based on the impacts arising from this mode split of trips.

**Table 7.1 – Indicative travel mode split**

Mode	Indicative modal split	
	Residential	Workplace
Underground / Light Rail	19.5%	14.4%
Train	15.4%	18.1%
Bus	25.5%	42.7%
Taxi	0.2%	0.4%
Motorcycle	0.6%	2.6%
Car driver	27.8%	0.0%
Car passenger	1.0%	0.0%
Bicycle	1.9%	4.0%
On Foot	7.5%	16.9%
Other	0.6%	0.9%
<b>Total</b>	<b>100.0%</b>	<b>100.0%</b>

## 8 TARGETS AND MONITORING

8.1.1 A Travel Plan is essentially a 'living document' which requires monitoring, review and revision to ensure it remains relevant to the organisation and those using the site and provides continuous improvements for its duration. This chapter sets out the targets for the Travel Plan and the monitoring and review process. Monitoring and review will be the responsibility of the STM

### 8.2 Targets

8.2.1 TfL provide recommendations on the requirements of targets as follows:

- Should be SMART, **S**pecific, **M**easureable, **A**ttainable, **R**ealistic, and **T**ime-bound, and should link to the objectives of the travel plan;
- Should enable measurement of success in achieving objectives of the travel plan;
- Enable enforcement; and
- A minimum five-year time frame, with interim targets at year one, three and five.

#### ***Residential***

8.2.2 The targets set out below are based on the approximate proposed modal split found in Table 7.1. The targets are set out over a minimum five-year time frame. These provisional targets are included in Table 8.1.

**Table 8.1 – Proposed residential targets by mode**

Mode	Baseline mode split	Change in mode split	
		Year 3	Year 5
Underground / Light Rail	19.5%	+2.5%	+5%
Rail	15.4%		
Bus	25.5%		
Car Driver	27.8%	-5%	-10%
Walking	7.5%	+5%	+10%
Cycling	1.9%	+75%	+150%

8.2.3 The above mode split target are indicative and will therefore require refinement once the results of the initial Travel Survey have been received. Over the longer term, targets include reducing the peak hour car driver mode split by 10% over 5 years and a 150% increase in cycling usage will be encouraged over 5 years in

accordance with the mayors Transport Strategy target for cycling as a mode share.

### **Commercial tenants**

8.2.4 The limited parking provision will ensure employees will naturally travel to and from the site via alternative more sustainable modes. The proposed mode split indicates that 97% of journeys made to the site by commercial tenants are by sustainable modes of transport. Therefore the commercial **tenant's** targets will be to maintain this modal split with a long term target of increasing the pedestrian modes have by 5% and cycle mode share by 25% in accordance with the Mayors Transport Strategy target for cycle use.

## **8.3 Monitoring**

8.3.1 The monitoring regime for the development has been determined with reference to the requirements set out in the TfL '**Travel Planning for New Developments in London**' guidance document. **This recommends that Travel Plan's be monitored** by means of a TRICS compliant survey.

8.3.2 The STM will arrange the initial full multi-modal travel survey to be undertaken for the development once a trigger point of 75% occupation is reached. The specification of the multi-modal surveys will be agreed within RBG prior to being undertaken, however, it is envisaged that the surveys will comprise the following components:

- Management questionnaire to identify site specific details (to be completed by the on-site management company);
- Core staff survey and travel diary for a sample of employees within the individual land uses.
- Pedestrian counts at the pedestrian access points into the site;
- Questionnaire/ interview surveys of residents within the site to identify the main mode share of the development.
- Visitor questionnaire surveys would be a personal interview targeting a sample of customers; and
- Vehicle movement and parking count, applicable to office land-uses only, spread throughout the day.

8.3.3 As required by the TfL guidance, a TRICS survey will be undertaken for the baseline survey; plus years 1, 3 and 5.

- 8.3.4 The precise dates of the future surveys will depend on the date of the baseline survey which will be undertaken once 75% of the development has been occupied. Therefore, at present, it is not possible to agree the calendar dates of the future surveys. These will be clarified and agreed after the initial surveys have been undertaken.
- 8.3.5 The surveys will form the basis for the monitoring reports which will be submitted to the Council one year after the baseline surveys, and then again three and five years after the baseline survey.

## **9 ACTION PLAN**

- 9.1.1 The programme for the implementation of the travel plan measures for the proposals will be produced, as and when, they are brought forward for development.
- 9.1.2 The action plan for the development will set out tasks, intended implementation dates and funding sources. It is intended to be a live document which will be updated by the STM to reflect the outcome of consultation with the local planning authority, once the first full multi-modal travel survey has been completed. The Residential and Commercial Action Plan for the development proposals is set out in Tables 9.1 and 9.2 respectively.

**Table 9.1 – Residential Action Plan**

Objective	Measures/Actions	When	Responsibility
- Raise awareness of sustainable modes of travel available	Appoint Sustainable Travel Manager (STM) and Travel Plan Co-ordinator (TPC)	Prior to first occupation	Developer
	Provide Travel Information Packs	When residents move in	STM
- Maintain the predicted sustainable travel patterns to and from the development; - Encourage users to move up within the sustainable transport hierarchy	Provide secure cycle parking in accordance with the standards set out in the Transport Assessment	Prior to occupation	Developer
	Ensure all units will be able to access broadband subject to signing up to an Internet Service Provider	At occupation	Developer
- Monitor Travel Plan targets are being met	Undertake a baseline survey	When 75% of development is occupied	Developer (via STM)
	Undertake TRICS compliant survey and prepare monitoring reports	Years 1, 3 and 5	

**Table 9.2- Commercial Action Plan**

Objective	Measures/Actions	When	Responsibility
- Raise awareness of sustainable modes of travel available	Appoint Sustainable Travel Manager (STM)	Prior to first occupation	Developer/ Estate Management Staff
	Provide Travel Information Packs		Site management (via STM)
- Promote healthy lifestyles and sustainable local communities by promoting health benefits of walking and cycling.	Provide Travel Information Packs	Upon occupation	Site management (via STM)
- Encourage users to move up within the sustainable transport hierarchy	Provide commercial cycle parking	Prior to first occupation	Developer
- Monitor the Travel Plan to see whether targets are being met	Undertake a baseline survey	When 75% of development is occupied	Developer (via STM)
	Undertake TRICS compliant survey and prepare monitoring reports	Years 1, 3 and 5	

## **Appendix A**

# ATTrBuTe

Travel plan name	Anchor and Hope Lane sites
Planning application reference number	
Name of travel plan author	Transport Planning Practice
Email address of travel plan author	email@tppweb.co.uk
Telephone number of travel plan author	02076080008
Name of travel plan assessor	Henry Binnian
Job title/role of travel plan assessor	
Plan Type	Strategic level   Framework   Travel Plan (occupiers known)

--

<b>The development</b>		<b>3/7</b>
Does the framework travel plan include a commitment for occupiers of the site to develop individual travel plans within the context of the overarching plan?	NONE	0
Does the travel plan include details of the number of users expected on site (including employees, residents, deliveries and visitors)?	NONE	0
Does the travel plan include a) a breakdown of the different land uses expected on site? b) details of the size of each type of land use? c) details of how build-out of the development will be phased?	Section 1,2 provides breakdown and size of each land use.	2
Does the travel plan include a) full address of the development? b) contact details for the person responsible for preparing the travel plan?	Contact details are provided on contents page	1
<b>Policy</b>		<b>1/2</b>
Does the travel plan include reference to relevant national, regional and local/borough... a) transport and spatial policy? b) travel planning guidance?	Travel Planning Guidance	1
<b>Site assessment</b>		<b>3/3</b>
To what extent does the travel plan clearly describe the accessibility and quality of... a) existing transport networks and initiatives? b) existing travel initiatives available to all users?	Chapter 2	3
<b>Surveys</b>		<b>3/3</b>
Is a baseline modal split (actual trip numbers and percentage of all trips) estimated for the site?	Indicative modal split is provided in table 7.1	1
Does the travel plan propose the following? a) TRAVL compliant site user travel and freight surveys? b) an agreed date with the borough for the surveys to take place?	TRICS compliant survey baseline survey after 75% of development is occupied	2

<b>Objectives</b>		<b>3/3</b>
Does the travel plan include objectives which reflect... a) Mayoral policy & strategic guidance? b) local / borough policy and guidance? c) the challenges and opportunities specific to the site?	Objectives provided in chapter 3.	3
<b>Targets</b>		<b>1/2</b>
Have targets appropriate to the phasing of the development been set?	NONE	0
Are there targets linking directly to each objective?	Chapter 8	1
<b>TP Co-ordinator</b>		<b>2/3</b>
Has the framework travel plan co-ordinator.... a) roles and responsibilities been made clear? b) been allocated a sufficient amount of time to spend on the travel plan?	roles a responsibilities are set out in chapter 4	1
Has a site-wide travel plan co-ordinator been identified or is there agreement upon when a co-ordinator will be in place?	an agreement is set out in the Travel Plan	1
<b>Measures</b>		<b>5/6</b>
To what extent do the site-wide measures... a) support the objectives of the travel plan? b) reflect the context of the site?	NONE	3
Is an action plan provided which includes... a) short / medium / long term actions? b) timescales and responsibilities?	NONE	2
Is the action plan clear on how and when travel plans will be developed among occupying organisations?	NONE	0
<b>Monitoring</b>		<b>2/2</b>
Is it clear who is responsible for site-wide monitoring?	Chapter 8	1
Is a clear site-wide monitoring programme that adheres to the standardised approach included?	Chapter 8	1
<b>Securing and enforcement</b>		<b>1/1</b>
Is it clear how the travel plan will be secured?	Section 4.4	1
<b>Funding</b>		<b>6/6</b>
Has a sufficient budget been set for the site-wide... a) travel plan co-ordinator post? b) measures? c) monitoring programme?	NONE	3
Have funding streams been identified for the site-wide... a) travel plan co-ordinator post? b) measures? c) monitoring programme?	NONE	3
<b>Total - PASS</b>		<b>30</b>

## **Annex H**

### Residential Trip Generation

30821 Charlton Riverside  
**Residential trip rates**

**Canary Central**  
 Units

554

	CANARY CENTRAL Occupants In							CANARY CENTRAL Occupants Out												
	Car occupancy				Car passenger	Car driver	Motorcycle	Cycle	Walk / PT	Total people	Car occupancy				Car passenger	Car driver	Motorcycle	Cycle	Walk / PT	Total people
	1	2	3	4+							1	2	3	4+						
0700-0800	4	0	0	0	0	4	0	1	6	11	6	1	0	0	1	7	1	0	143	152
0800-0900	6	1	0	1	4	8	0	0	9	21	6	2	0	1	5	9	0	1	303	318
0900-1000	4	3	1	0	4	8	0	0	17	29	1	0	0	0	5	1	0	0	89	95
1600-1700	10	8	0	0	8	18	0	0	40	66	5	1	1	1	6	8	0	0	13	27
1700-1800	9	3	0	0	3	12	1	0	77	93	8	2	1	0	4	11	1	0	15	31
1800-1900	7	8	1	0	10	16	1	0	166	193	17	2	0	0	2	19	0	0	34	55

**NWP BUILDING**  
 Units

559

	NWP BUILDING Occupants In							NWP BUILDING Occupants Out												
	Car occupancy				Car passenger	Car driver	Motorcycle	Cycle	Walk / PT	Total people	Car occupancy				Car passenger	Car driver	Motorcycle	Cycle	Walk / PT	Total people
	1	2	3	4+							1	2	3	4+						
0700-0800	6	1	0	0	1	7	2	2	27	39	12	5	1	0	7	18	1	1	155	182
0800-0900	8	2	0	0	2	10	0	0	15	27	10	4	0	0	4	14	1	0	232	251
0900-1000	11	2	1	0	4	14	0	0	20	38	13	5	0	0	5	18	0	0	93	116
1600-1700	9	6	0	0	6	15	0	0	20	41	14	5	0	0	5	19	0	0	23	47
1700-1800	9	7	0	0	7	16	2	0	67	92	3	6	0	1	9	10	1	0	37	57
1800-1900	14	7	4	3	24	28	0	1	114	167	15	3	3	1	12	22	0	0	43	77

**KEMPTON CRT**  
 Units

80

	KEMPTON CRT Occupants In							KEMPTON CRT Occupants Out												
	Car occupancy				Car passenger	Car driver	Motorcycle	Cycle	Walk / PT	Total people	Car occupancy				Car passenger	Car driver	Motorcycle	Cycle	Walk / PT	Total people
	1	2	3	4+							1	2	3	4+						
0700-0800	1	0	0	0	0	1	0	0	2	3	2	0	1	0	2	3	0	2	17	24
0800-0900	2	1	0	0	1	3	0	0	6	10	0	1	0	0	1	1	0	3	53	58
0900-1000	0	1	0	0	1	1	0	1	4	7	1	0	0	0	0	1	0	1	14	16
1600-1700	0	0	0	0	0	0	0	1	9	10	0	0	0	0	0	0	2	8	10	
1700-1800	4	0	0	0	0	4	0	4	26	34	2	0	0	0	0	2	0	1	14	17
1800-1900	1	0	0	0	0	1	0	0	20	21	2	0	0	0	0	2	0	0	16	18

**CITY WALK**  
 Units

110

	CITY WALK Occupants In							CITY WALK Occupants Out												
	Car occupancy				Car passenger	Car driver	Motorcycle	Cycle	Walk / PT	Total people	Car occupancy				Car passenger	Car driver	Motorcycle	Cycle	Walk / PT	Total people
	1	2	3	4+							1	2	3	4+						
0700-0800	0	0	0	0	0	0	1	3	5	0	0	0	0	0	0	0	0	1	19	20
0800-0900	0	0	0	0	0	0	0	1	1	1	0	1	0	0	1	1	2	4	42	50
0900-1000	5	0	0	0	0	5	2	0	5	12	1	1	0	0	1	2	3	1	9	16
1600-1700	0	0	0	0	0	0	0	17	17	17	1	0	0	0	0	1	1	0	12	14
1700-1800	3	0	0	0	0	3	1	3	12	19	1	0	0	0	0	1	1	0	8	10
1800-1900	4	0	0	0	0	4	0	2	18	24	0	0	0	0	0	0	0	2	11	13

**BOW QUARTER**  
 Units

773

	BOW QUARTER Occupants In							BOW QUARTER Occupants Out												
	Car occupancy				Car passenger	Car driver	Motorcycle	Cycle	Walk / PT	Total people	Car occupancy				Car passenger	Car driver	Motorcycle	Cycle	Walk / PT	Total people
	1	2	3	4+							1	2	3	4+						
0700-0800	3	1	0	0	1	4	1	0	19	25	13	7	0	0	7	20	4	16	195	242
0800-0900	11	1	0	0	1	12	1	0	23	37	16	3	1	0	5	20	6	17	320	368
0900-1000	7	0	0	0	0	7	0	0	23	30	7	0	0	0	7	2	10	115	134	
1600-1700	9	3	0	0	3	12	2	1	41	59	6	1	0	0	1	7	0	3	35	46
1700-1800	11	4	0	0	4	15	1	7	90	117	4	0	0	0	4	4	1	1	28	34
1800-1900	15	6	0	0	6	21	2	16	194	239	9	2	0	0	2	11	1	2	55	71

**Residential units per development**

Site	Units
Canary Central	554
NPW Building	559
Kempton Crt	80
City Walk	110
Bow Quarter	773
<b>Total</b>	<b>2076</b>

**Total Trips (taken from the 5 sites above)**

	Occupants In							Occupants Out												
	Car occupancy				Car passenger	Car driver	Motorcycle	Cycle	Walk / PT	Total people	Car occupancy				Car passenger	Car driver	Motorcycle	Cycle	Walk / PT	Total people
	1	2	3	4+							1	2	3	4+						
0700-0800	14	2	0	0	2	16	4	4	57	83	33	13	2	0	17	48	7	19	529	620
0800-0900	27	5	0	1	8	33	1	0	54	96	32	11	1	1	16	45	9	25	950	1045
0900-1000	27	6	2	0	9	35	2	1	69	116	23	6	0	0	11	29	5	12	320	377
1600-1700	28	17	0	0	17	45	2	2	127	193	26	7	1	1	12	35	1	5	91	144
1700-1800	36	14	0	0	14	50	5	14	272	355	18	8	1	1	13	28	4	2	102	149
1800-1900	41	21	5	3	40	70	3	19	512	644	43	7	3	1	16	54	1	4	159	234

**Trips Rates (derived from the 5 sites above)**

	Occupants In							Occupants Out												
	Car occupancy				Car passenger	Car driver	Motorcycle	Cycle	Walk / PT	Total people	Car occupancy				Car passenger	Car driver	Motorcycle	Cycle	Walk / PT	Total people
	1	2	3	4+							1	2	3	4+						
0700-0800	0.007	0.001	0.000	0.000	0.001	0.008	0.002	0.002	0.027	0.040	0.016	0.006	0.001	0.000	0.008	0.023	0.003	0.009	0.255	0.299
0800-0900	0.013	0.002	0.000	0.000	0.004	0.016	0.000	0.000	0.026	0.046	0.015	0.005	0.000	0.000	0.008	0.022	0.004	0.012	0.458	0.503
0900-1000	0.013	0.003	0.001	0.000	0.004	0.017	0.001	0.000	0.033	0.056	0.011	0.003	0.000	0.000	0.005	0.014	0.002	0.006	0.154	0.182
1600-1700	0.013	0.008	0.000	0.000	0.008	0.022	0.001	0.001	0.061	0.093	0.013	0.003	0.000	0.000	0.006	0.017	0.000	0.002	0.044	0.069
1700-1800	0.017	0.007	0.000	0.000	0.007	0.024	0.002	0.007	0.131	0.171	0.009	0.004	0.000	0.000	0.006	0.013	0.002	0.001	0.049	0.072
1800-1900	0.020	0.010	0.002	0.001	0.019	0.034	0.001	0.009	0.247	0.310	0.021	0.003	0.001	0.000	0.008	0.026	0.000	0.002	0.077	0.113

**Residential Trip generation****Units**

771

	0800 - 0900			17:00 - 18:00		
	In	Out	Total	In	Out	Total
Person trip rate	0.046	0.504	0.550	0.311	0.113	0.423
Persons trips	35	389	424	240	87	327

Mode	Mode share	0800 - 0900			17:00 - 18:00		
		In	Out	Total	In	Out	Total
Underground / Light Rail (via bus)	15.4%	5.4	59.9	65.3	37.0	13.4	50.4
Underground / Light Rail (via rail)	4.1%	1.4	15.9	17.4	9.8	3.6	13.4
Train	15.4%	5.4	59.7	65.1	36.8	13.4	50.2
Bus	25.5%	8.9	99.3	108.2	61.2	22.2	83.4
Taxi	0.2%	0.1	0.8	0.9	0.5	0.2	0.7
Motorcycle	0.6%	0.2	2.4	2.6	1.5	0.5	2.0
Car driver	27.8%	9.7	108.1	117.9	66.7	24.2	90.9
Car passenger	1.0%	0.4	4.0	4.4	2.5	0.9	3.4
Bicycle	1.9%	0.7	7.3	7.9	4.5	1.6	6.1
On Foot	7.5%	2.6	29.1	31.7	17.9	6.5	24.4
Other	0.6%	0.2	2.4	2.6	1.5	0.5	2.0
Total	100.0%	35.0	389.0	424.0	240.0	87.0	327.0

**Proposed numbers with rounding errors corrected:**

Mode	Mode share	0800 - 0900			17:00 - 18:00		
		In	Out	Total	In	Out	Total
Underground / Light Rail	15%	6	60	66	37	13	50
Underground / Light Rail	4%	1	16	17	10	4	14
Train	15%	5	60	65	37	13	50
Bus	26%	9	99	108	61	22	83
Taxi	0%	0	1	1	0	0	0
Motorcycle	1%	0	3	3	2	1	3
Car driver	28%	10	108	118	67	24	91
Car passenger	1%	0	4	4	2	1	3
Bicycle	2%	1	7	8	5	2	7
On Foot	7%	3	29	32	18	6	24
Other	1%	0	2	2	1	1	2
Total	100.0%	35	389	424	240	87	327

Mode share from Greenwich 004B LSOA

## **Annex I**

### Non-Residential Trip Generation

**Proposed B1 trips**

Number of employees  
85% of employees present  
within the building to take  
account of illness, meeting,

295
251

**Mode share**

The mode share for the proposed commercial staff is expected to be similar to existing staff in the local area. 2011 travel to work data for the workday population in Greenwich 004 has been examined. These have then been redistributed to take into account the proposed car parking provision.

Mode	Mode share	Re-distributed
Underground / light rail	6.9%	14.4%
Train	8.6%	18.1%
Bus	20.4%	42.7%
Taxi	0.2%	0.4%
Motorcycle	1.2%	2.6%
Car driver	49.1%	0.0%
Car passenger	3.2%	0.0%
Bicycle	1.9%	4.0%
On foot	8.1%	16.9%
Other	0.4%	0.9%
Total	100.0%	100.0%

**Canary Wharf Employee Survey**

	AM Peak		PM Peak	
	In	Out	In	Out
Employees	46.8%	10.0%	18.0%	35.3%

Source: Canary Wharf Employee Travel Survey 2007

	AM Peak		PM Peak	
	In	Out	In	Out
Proposed	117	25	45	89

**Proposed commercial trips**

Mode	Mode share	AM Peak			PM Peak		
		In	Out	Total	In	Out	Total
Underground / light rail (via bus)	6.8%	8.0	1.7	10	3.1	6.0	9
Underground / light rail (via rail)	7.6%	8.9	1.9	11	3.4	6.7	10
Train	18.1%	21.3	4.5	26	8.2	16.0	24
Bus	42.7%	50.2	10.7	61	19.3	37.8	57
Taxi	0.4%	0.5	0.1	1	0.2	0.4	1
Motorcycle	2.6%	3.1	0.7	4	1.2	2.3	3
Car driver	0.0%	0.0	0.0	0	0.0	0.0	0
Car passenger	0.0%	0.0	0.0	0	0.0	0.0	0
Bicycle	4.0%	4.7	1.0	6	1.8	3.5	5
On foot	16.9%	19.9	4.2	24	7.6	15.0	23
Other	0.9%	1.1	0.2	1	0.4	0.8	1
Total	100.0%	117	25	143	45	89	134

**Proposed numbers with rounding errors corrected:**

Mode	Mode share	AM Peak			PM Peak		
		In	Out	Total	In	Out	Total
Underground / light rail (via bus)	6.8%	8	2	10	3	6	9
Underground / light rail (via rail)	7.6%	9	2	11	4	7	11
Train	18.1%	21	4	25	8	16	24
Bus	42.7%	50	11	61	19	38	57
Taxi	0.4%	0	0	0	0	0	0
Motorcycle	2.6%	3	1	4	1	2	3
Car driver	0.0%	0	0	0	0	0	0
Car passenger	0.0%	0	0	0	0	0	0
Bicycle	4.0%	5	1	6	2	4	6
On foot	16.9%	20	4	24	8	15	23
Other	0.9%	1	0	1	0	1	1
Total	100.0%	117	25	142	45	89	134

**D1 nursery****Staff**

16

Mode	Mode share	AM Peak			PM Peak		
		In	Out	Total	In	Out	Total
Underground / light rail (via bus)	6.8%	1.1		1		1.1	1
Underground / light rail (via rail)	7.6%	1.2		1		1.2	1
Train	18.1%	2.9		3		2.9	3
Bus	42.7%	6.8		7		6.8	7
Taxi	0.4%	0.1		0		0.1	0
Motorcycle	2.6%	0.4		0		0.4	0
Car driver	0.0%	0.0		0		0.0	0
Car passenger	0.0%	0.0		0		0.0	0
Bicycle	4.0%	0.6		1		0.6	1
On foot	16.9%	2.7		3		2.7	3
Other	0.9%	0.1		0		0.1	0
Total	100.0%	16.0		16		16.0	16

**Proposed numbers with rounding errors corrected:**

Mode	Mode share	AM Peak			PM Peak		
		In	Out	Total	In	Out	Total
Underground / light rail (via bus)	6.8%	1	0	1	0	1	1
Underground / light rail (via rail)	7.6%	1	0	1	0	1	1
Train	18.1%	3	0	3	0	3	3
Bus	42.7%	7	0	7	0	7	7
Taxi	0.4%	0	0	0	0	0	0
Motorcycle	2.6%	0	0	0	0	0	0
Car driver	0.0%	0	0	0	0	0	0
Car passenger	0.0%	0	0	0	0	0	0
Bicycle	4.0%	1	0	1	0	1	1
On foot	16.9%	3	0	3	0	3	3
Other	0.9%	0	0	0	0	0	0
Total	100.0%	16	0	16	0	16	16

**Children**

56

Mode	Mode share	AM Peak			PM Peak		
		In	Out	Total	In	Out	Total
Underground / light rail (via bus)		0	0	0	0	0	0
Underground / light rail (via rail)							
Train		0	0	0	0	0	0
Bus		0	0	0	0	0	0
Taxi		0	0	0	0	0	0
Motorcycle		0	0	0	0	0	0
Car driver		0	0	0	0	0	0
Car passenger		0	0	0	0	0	0
Bicycle		0	0	0	0	0	0
On foot		112	56	168	56	112	168
Other		0	0	0	0	0	0
Total		112	56	168	56	112	168

**Total**

Mode	Mode share	AM Peak			PM Peak		
		In	Out	Total	In	Out	Total
Underground / light rail (via bus)		1	0	1	0	1	1
Underground / light rail (via rail)		1	0	1	0	1	1
Train		3	0	3	0	3	3
Bus		7	0	7	0	7	7
Taxi		0	0	0	0	0	0
Motorcycle		0	0	0	0	0	0
Car driver		0	0	0	0	0	0
Car passenger		0	0	0	0	0	0
Bicycle		1	0	1	0	1	1
On foot		115	56	171	56	115	171
Other		0	0	0	0	0	0
Total		128	56	184	56	128	184

## **Annex J**

### Bus Analysis Report



# Leopard Guernsey Anchor Propco Ltd

Anchor and Hope Lane Sites  
Bus Analysis

30821/D010e  
December 2017



**Contents**

1 Introduction..... 1

2 Existing Residential Travel Patterns by Bus ..... 4

3 Residential Bus Trip Generation..... 7

4 Residential Bus Trip Distribution ..... 10

5 Flexible Commercial Staff Bus Trip Generation ..... 12

6 Commercial Staff Bus Trip Distribution ..... 14

7 Total Development Bus Trip Distribution..... 16

**Appendices**

A Bus Calculations



# 1 INTRODUCTION

## 1.1 Background Context

1.1.1 Transport Planning Practice (TPP) has been appointed by Leopard Guernsey Anchor Propco Ltd to provide transport advice in relation to the proposed redevelopment of the VIP Trading Estate and the VIP Industrial Estate site located on Anchor and Hope Lane within the Royal Borough of Greenwich (RBG).

1.1.2 The site sits within a currently predominately industrial area located between Woolwich Road (A206) and the southern bank of the River Thames. The main access to the site is from Anchor & Hope Lane which runs between Woolwich Road and Bugsby's Way. The site consists of two plots of development, Plot A (Northern Plot) and Plot B (Southern Plot) with a strip connecting to Anchor & Hope Lane to the west and another to the north towards the Thames Path. Figure 1.1 shows the location of the site.

**Figure 1.1 - Site Location**

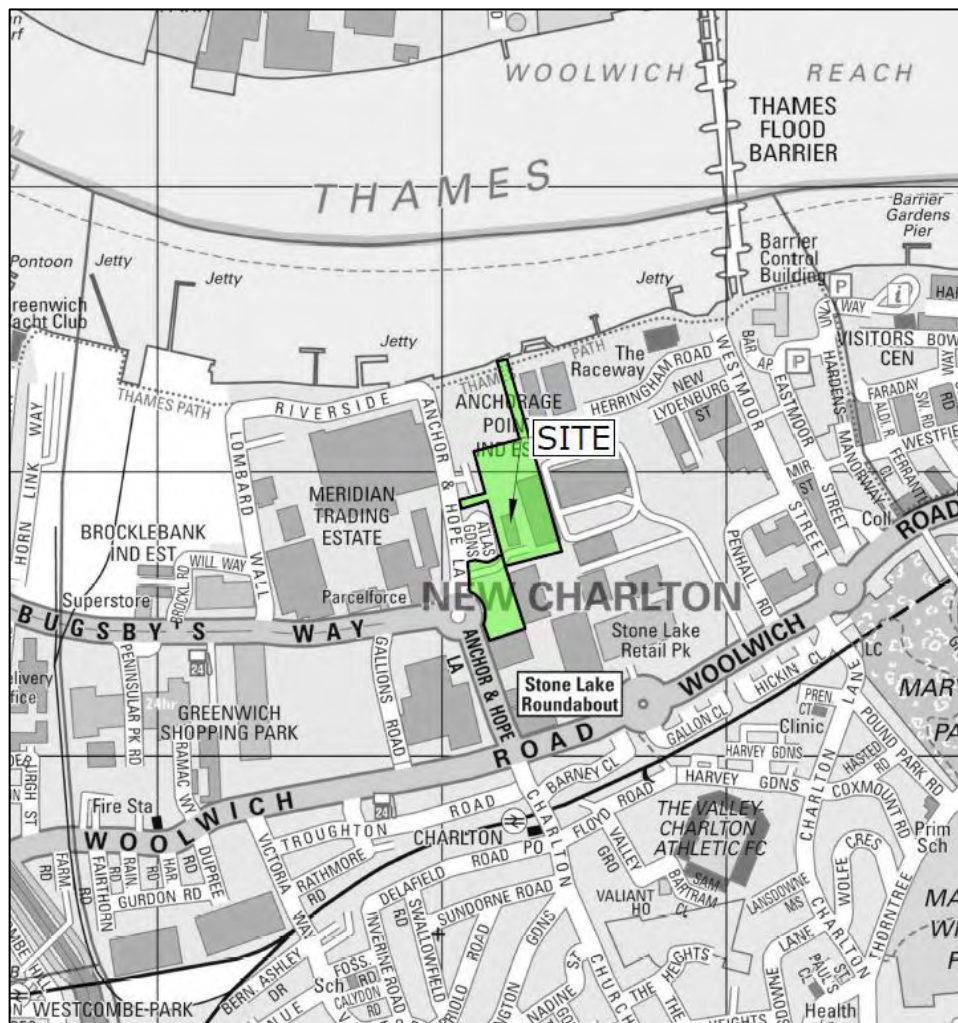

1.1.3 The proposed development will provide 771 units residential as well as flexible commercial space (A1-A3/B1/D1/D2). The scheme will provide the following:

- 771 residential units, including extensive private gardens and roof terraces;
- 3,236 sqm of flexible commercial space;
- Ancillary residential facilities totalling 496 sqm;
- 337 sqm of community uses; and
- Extensive external public realm improvements and landscaping.

## 1.2 Report Purpose

1.2.1 An assessment has been undertaken to evaluate the level of bus trips which could be expected to be generated by the proposed development. This report sets out the trip generation methodology and distribution by journey purpose, for all bus trips generated from the development site associated with the following six time periods:

- 0400-0700 (Night time)
- 0700-1000 (AM peak)
- 1000-1600 (Day time)
- 1600-1900 (PM peak)
- 1900-2200 (Evening); and
- 2200-0400 (Night time).

1.2.2 This report is set out as follows and a copy of all of the calculations is contained within Appendix A.

- **Chapter 2: Existing travel patterns by bus** – summarises the existing residential travel patterns by bus in Inner London.

- **Chapter 3: Residential bus trip generation** – sets out the methodology for estimating residential bus trips for the proposed development.
- **Chapter 4: Residential bus trip distribution** – sets out how the residential bus trips for the proposed development have been distributed.
- **Chapter 5: Commercial staff bus trip generation** – sets out how the methodology for estimating staff bus trips for the proposed development.
- **Chapter 6: Commercial staff bus trip distribution** – sets out how the staff bus trips for the proposed development have been distributed.
- **Chapter 7: Total development bus trip distribution** – sets out the total developments bus trip distribution.

## 2 EXISTING RESIDENTIAL TRAVEL PATTERNS BY BUS

### 2.1 Introduction

2.1.1 This chapter sets out the analysis of the London Travel Demand Survey's (LTDS) for 2010-2013, including the daily profile of residential bus trips and journey purpose by bus. The full analysis of the data is included in Appendix A and summarised within this report.

### 2.2 Residential bus trips

2.2.1 The London Travel Demand Survey (LTDS) is a continuous household survey of the London area, covering all London boroughs and the City of London. Three years of LTDS data are combined (2010-2013) to provide average figures to ensure a large enough sample size to give robust results. This data has been examined for Inner London, excluding Central London:

- **Inner London** consists of London boroughs of Camden, Hackney, Hammersmith & Fulham, Haringey, Islington, Kensington & Chelsea, Lambeth, Lewisham, Newham, Southwark, Tower Hamlets, Wandsworth, the City of Westminster, and the City of London.
- **Central London** is defined as an area roughly rectangular in shape, bounded by Regent's Park to the north, Whitechapel to the east, Elephant & Castle and Vauxhall to the south, and Kensington Gardens to the west.

2.2.2 The LTDS has been used to determine the inbound and outbound total person trips, for all modes of transport and journey purposes, associated with all surveyed households in Inner London (excluding Central London). These are summarised in Table 2.1.

**Table 2.1 - LTDS Total Person Trips for Inner London (excluding Central London)**

Time Period	Total Person Trips from LTDS		
	Inbound	Outbound	Two-way
0400-0700	10,790	139,000	149,790
0700-1000	167,300	1,322,670	1,489,970
1000-1600	1,060,570	1,033,140	2,093,710
1600-1900	833,690	337,260	1,170,950
1900-2200	373,560	183,220	556,780
2200-0400	200,410	27,470	227,880

2.2.3 The proportions of LTDS total person trips which are bus trips have been derived for inbound and outbound journeys, per time period, for all surveyed households. The daily profile of residential bus trips over the day are shown in Table 2.2.

**Table 2.2 - Daily Profile of Residential Bus Trips for Inner London (excluding Central London)**

Time Period	% of LTDS Bus Trips to Total Person Trips	
	Inbound	Outbound
0400-0700	15%	24%
0700-1000	11%	22%
1000-1600	24%	25%
1600-1900	19%	15%
1900-2200	15%	13%
2200-0400	19%	10%

## 2.3 Residential journey purpose by bus

2.3.1 The LTDS data has been examined for journey purpose. The percentages of LTDS bus trips for each journey purpose (work, education, shopping and personal business, leisure, and other) associated with all inbound and outbound trips to and from households within Inner London, excluding Central London, have been calculated. The percentages in Table 2.2 have been split by journey purpose and the results are set out in Tables 2.3 and 2.4 below.

**Table 2.3 - LTDS Inbound Journey Purpose by Bus**

Time Period	Inbound				
	Work	Education	Shopping and personal business	Leisure	Other (inc Escort/Worship)
0400-0700	67%	0%	33%	0%	0%
0700-1000	15%	1%	31%	13%	41%
1000-1600	10%	24%	50%	10%	6%
1600-1900	33%	17%	29%	17%	4%
1900-2200	29%	4%	9%	48%	10%
2200-0400	31%	1%	4%	58%	6%

**Table 2.4 - LTDS Outbound Journey Purpose by Bus**

Time Period	Outbound				
	Work	Education	Shopping and personal business	Leisure	Other (inc Escort/Worship)
0400-0700	89%	2%	3%	5%	1%
0700-1000	39%	39%	10%	4%	7%
1000-1600	12%	5%	54%	22%	7%
1600-1900	13%	6%	28%	36%	17%
1900-2200	18%	0%	4%	62%	15%
2200-0400	47%	0%	13%	41%	0%

### 3 RESIDENTIAL BUS TRIP GENERATION

#### 3.1 Introduction

3.1.1 This chapter sets out the methodology for estimating bus trips for the proposed 771 residential apartments.

#### 3.2 Person trips

3.2.1 In order to determine the number of total person trips associated with the residential land use, the following peak period trip surveys have been used. This method has been agreed with TfL when scoping the Transport Assessment (TA).

- Canary Central, Lighterman's Road, E14 (April 2006) – 544 residential apartments (private & affordable);
- New Providence Wharf Building A, E14 (March 2006) – 559 residential apartments (private);
- Kempton Court, Whitechapel E1 (April 2006) – 80 residential apartments (private);
- City Walk, Shoreditch E2 (July 2006) – 110 residential apartments (private); and
- Bow Quarter, Bow E3 (July 2006) – 773 residential apartments and houses (private and affordable).

3.2.2 The surveys were undertaken between the hours of 0700 - 1000 (AM peak hour period) and 1600 - 1900 (PM peak hour period). Total person trip rates were then derived and applied to the proposed 771 units and these are summarised in Table 3.1. Further details of the trip generation are contained within the TA.

**Table 3.1 - Total Development Person Trips in the Peak Periods**

	<b>Time period</b>	<b>Inbound</b>	<b>Outbound</b>	<b>Total two-way</b>
AM	0700-0800	31	230	868
	0800-0900	36	388	
	0900-1000	43	140	
PM	1600-1700	72	53	638
	1700-1800	132	55	
	1800-1900	239	87	

3.2.3 The total person trips associated with all the other time periods being assessed for this bus analysis have been calculated by applying a factor of 0.016% to LTDS data contained within Table 2.1. This factor is the average proportion of the peak period development trips to the LTDS peak period trips and has been derived by undertaking the following calculation:

$$\frac{\text{Total development person trips for the AM \& PM peak periods}}{\text{Total person trips in the LTDS data for the AM \& PM peak period}} = 0.016\%$$

3.2.4 The estimated total development person trips by time period over 24-hours are summarised in Table 3.2.

**Table 3.2 - Total Development Person Trips**

Time Period	Total Person Trips		
	Inbound	Outbound	Two - Way
0400-0700	6	79	85
0700-1000	110	758	868
1000-1600	600	585	1185
1600-1900	443	196	639
1900-2200	211	104	315
2200-0400	113	16	129

*Note: 0700-1000 and 1600-1900 person trips calculated based on surveys. Other time periods calculated by applying a factor of 0.056% to the LTDS data.*

### 3.3 Residential bus trip generation

3.3.1 The residential bus trips for the proposed development have been estimated using the proportion of LTDS total person trips which are bus trips. These proportions (as set out in Table 2.2) have been applied to the total development person trips shown in the above table.

3.3.2 The resulting daily profile of residential bus trips are shown in Table 3.3 below.

**Table 3.3 - Total Development Residential Bus Trips**

Time Period	Inbound	Outbound	Total
0400-0700	1	19	20
0700-1000	12	164	176
1000-1600	142	144	286
1600-1900	86	30	116
1900-2200	31	14	45
2200-0400	21	2	23

3.3.3 The total residential bus trips have then been split by journey purpose. This is based on the percentages of bus trips by journey purpose derived from the LTDS data (as set out in Tables 2.3 and 2.4). This provides a daily profile of

development bus trips by journey purpose and the results for inbound trips are summarised in Table 3.4 and outbound trips are summarised in Table 3.5.

**Table 3.4 - Daily Profile of Inbound Residential Bus Trips by Journey Purpose**

Time Period	Inbound					Total
	Work	Education	Shopping and personal business	Leisure	Other (inc Escort/ Worship)	
0400-0700	1	0	0	0	0	1
0700-1000	2	0	4	1	5	12
1000-1600	14	35	70	14	9	142
1600-1900	28	14	24	15	4	86
1900-2200	9	1	3	15	3	31
2200-0400	6	0	1	12	1	21

**Table 3.5 - Daily Profile of Outbound Residential Bus Trips by Journey Purpose**

Time Period	Outbound					Total
	Work	Education	Shopping and personal business	Leisure	Other (inc Escort/ Worship)	
0400-0700	17	0	1	1	0	19
0700-1000	64	64	17	7	12	164
1000-1600	17	8	78	31	10	144
1600-1900	4	2	8	11	5	30
1900-2200	3	0	1	9	2	14
2200-0400	1	0	0	1	0	2

## 4 RESIDENTIAL BUS TRIP DISTRIBUTION

4.1.1 This chapter sets out the methodology used to distribute residential bus trips established in Chapter 3 for the proposed development.

### 4.2 Trip distribution proportions

4.2.1 The geographical location of local employment zones, secondary schools, shopping and leisure facilities from the site have been examined in order to determine the distribution of bus trips. The distribution of trips per journey purpose is summarised in Table 4.1 below.

**Table 4.1 - Distribution of Bus Trips by Direction and Purpose**

Journey Purpose	West	East	North	South
Work	50%	30%	0%	20%
Education	20%	50%	0%	30%
Shopping and personal business	50%	40%	0%	10%
Leisure	45%	35%	0%	20%
Other	40%	30%	0%	30%

### 4.3 Residential bus trip distribution

4.3.1 The bus distribution percentages in the above table have been applied to the daily profile of development bus trips (Tables 3.4 and 3.5). The results are shown in Table 4.2, 4.3 and 4.4.

**Table 4.2 - Distribution of Residential Inbound Bus Trips**

Time Period	Inbound			
	West	East	North	South
0400-0700	0	0	0	0
0700-1000	5	4	0	3
1000-1600	59	57	0	26
1600-1900	37	32	0	16
1900-2200	14	11	0	6
2200-0400	10	7	0	4

**Table 4.3 - Distribution of Residential Outbound Bus Trips**

Time Period	Outbound			
	West	East	North	South
0400-0700	9	6	0	4
0700-1000	61	64	0	39
1000-1600	67	54	0	23
1600-1900	13	11	0	6
1900-2200	6	5	0	3
2200-0400	1	1	0	0

**Table 4.4 - Distribution of Residential Two-way Bus Trips**

Time Period	Two-way			
	West	East	North	South
0400-0700	10	6	0	4
0700-1000	67	68	0	41
1000-1600	126	111	0	49
1600-1900	51	42	0	22
1900-2200	20	15	0	9
2200-0400	11	8	0	5

## 5 FLEXIBLE COMMERCIAL STAFF BUS TRIP GENERATION

### 5.1 Introduction

5.1.1 This chapter sets out the methodology for estimating staff bus trips generated from the proposed flexible commercial land use and community space. It should be noted that the proposed ancillary residential space of the proposed development would not generate noticeable trips due to its ancillary nature. In addition a worse case assessment based on considering all of the flexible commercial space as B1 office would result in a robust assessment of bus trips.

### 5.2 Flexible commercial staff bus trips

5.2.1 LTDS data was considered suitable to use for flexible commercial and nursery staff trips. It is estimated that the proposed commercial uses would have a daily staffing of 295 employees with the nursery having 16 members of staff on a typical day and therefore there would be 311 employees on site in total. The resulting daily profile of staff trips are shown in Table 5.1 below.

**Table 5.1 - Total Development Commercial Staff Trips**

Time Period	Inbound	Outbound	Total
0400-0700	50	3	53
0700-1000	190	9	199
1000-1600	50	72	122
1600-1900	12	146	158
1900-2200	6	47	53
2200-0400	3	34	37

5.2.2 Table 5.1 shows that the proposed commercial uses are expected to generate 311 two-way employee trips throughout the entire day. To calculate the number of staff who would travel to the site by bus the 2011 Census 'method of travel to work data' for the Lower Layer Super Output Area of Greenwich 004 was used. The mode share data was adjusted to remove vehicular trips and account for 'second leg' bus trips made to the site from Greenwich. The staff mode share has been calculated to be 49.5%. Table 5.2 presents the expected number of staff who travel to the site by bus during each time period.

**Table 5.2 - Total Development Commercial Staff Bus Trips**

<b>Time Period</b>	<b>Inbound</b>	<b>Outbound</b>	<b>Total</b>
0400-0700	25	2	27
0700-1000	94	5	99
1000-1600	25	35	60
1600-1900	6	72	78
1900-2200	3	23	26
2200-0400	2	17	19

## 6 COMMERCIAL STAFF BUS TRIP DISTRIBUTION

6.1.1 This chapter sets out the methodology used to distribute commercial staff bus trips established in Chapter 5 for the proposed commercial uses.

### 6.2 Trip distribution proportions

6.2.1 Census 2011 'place of work' data has been analysed for employees working within Greenwich to obtain the proposed bus trip distribution which is presented in Table 6.1 below.

**Table 6.1 - Distribution of Bus Trips by Direction**

	West	East	North	South
Trip distribution by %	30	40	0	30

### 6.3 Staff bus trip distribution

6.3.1 The bus distribution percentages in the above table have been applied to the daily profile of development bus trips in Tables 6.2, 6.3 and 6.4.

**Table 6.2 - Distribution of Staff Inbound Bus Trips**

Time Period	Inbound			
	West	East	North	South
0400-0700	7	10	0	7
0700-1000	28	38	0	28
1000-1600	7	10	0	7
1600-1900	2	2	0	2
1900-2200	1	1	0	1
2200-0400	0	1	0	0

**Table 6.3 - Distribution of Staff Outbound Bus Trips**

Time Period	Outbound			
	West	East	North	South
0400-0700	0	1	0	0
0700-1000	1	2	0	1
1000-1600	11	14	0	11
1600-1900	22	29	0	22
1900-2200	7	9	0	7
2200-0400	5	7	0	5

**Table 6.4 - Distribution of Staff Two-way Bus Trips**

Time Period	Two-way			
	West	East	North	South
0400-0700	8	10	0	8
0700-1000	30	39	0	30
1000-1600	18	24	0	18
1600-1900	24	31	0	24
1900-2200	8	10	0	8
2200-0400	6	7	0	6

## 7 TOTAL DEVELOPMENT BUS TRIP DISTRIBUTION

7.1.1 This chapter combines the residential and commercial staff bus trip distribution to generate the total bus trip distribution for the entire development. Tables 7.1, 7.2 and 7.3 provide a summary of the proposed bus trip distribution for the development.

**Table 7.1 - Distribution of proposed Inbound Bus Trips**

Time Period	Inbound			
	West	East	North	South
0400-0700	7	10	0	7
0700-1000	33	42	0	31
1000-1600	66	67	0	33
1600-1900	39	34	0	18
1900-2200	15	12	0	7
2200-0400	10	8	0	4

**Table 7.2 - Distribution of proposed Outbound Bus Trips**

Time Period	Outbound			
	West	East	North	South
0400-0700	9	7	0	4
0700-1000	62	66	0	40
1000-1600	78	68	0	34
1600-1900	35	40	0	28
1900-2200	13	14	0	10
2200-0400	6	8	0	5

**Table 7.3 - Distribution of proposed Two-way Bus Trips**

Time Period	Two-way			
	West	East	North	South
0400-0700	18	16	0	12
0700-1000	97	107	0	71
1000-1600	144	135	0	67
1600-1900	75	73	0	46
1900-2200	28	25	0	17
2200-0400	17	15	0	11

7.1.2 Tables 7.1, 7.2 and 7.3 above provide Transport for London with the information they require in order to assess the effects of the development proposals on their current and future bus network.

# **Appendix A**

## Bus Calculations

## London Travel Demand Survey 2010-2013 (Inner London, excluding Central London)

## 0400-0700 (Inbound)

Mode	01 Usual workplace	02 Other work related	03 Education	04 Shopping and personal business	05 Leisure	06 Other (inc Escort/Worship)	Total
01 National Rail/Overground	0						0
02 Underground/DLR	350			410			760
03 Bus (+sch/wk bus/coach/tram)	1050			520	0		1570
04 Taxi/Other							
05 Car (+ van/lorry/mcycle)	2400	390		530		1310	4630
06 Walk/Cycle				870	2960	0	3830
Total	3800	390		2330	2960	1310	10790

## 0400-0700 (Outbound)

Mode	01 Usual workplace	02 Other work related	03 Education	04 Shopping and personal business	05 Leisure	06 Other (inc Escort/Worship)	Total
01 National Rail/Overground	12620	5600	720		370		19310
02 Underground/DLR	23180	4510	260		190	690	28830
03 Bus (+sch/wk bus/coach/tram)	24780	5340	810	1020	1780	200	33930
04 Taxi/Other	900	270		340	320	740	2570
05 Car (+ van/lorry/mcycle)	16930	10300	80	830	1350	3300	32790
06 Walk/Cycle	13740	2100	360	860	4100	410	21570
Total	92150	28120	2230	3050	8110	5340	139000

## 0700-1000 (Inbound)

Mode	01 Usual workplace	02 Other work related	03 Education	04 Shopping and personal business	05 Leisure	06 Other (inc Escort/Worship)	Total
01 National Rail/Overground	390	190				1030	1610
02 Underground/DLR	2000	1340		270	1130	880	5620
03 Bus (+sch/wk bus/coach/tram)	2130	520	180	5620	2280	7430	18160
04 Taxi/Other							
05 Car (+ van/lorry/mcycle)	1190	150		5660	3080	29840	39920
06 Walk/Cycle	2220	1180	770	21290	12080	64450	101990
Total	7930	3380	950	32840	18570	103630	167300

## 0700-1000 (Outbound)

Mode	01 Usual workplace	02 Other work related	03 Education	04 Shopping and personal business	05 Leisure	06 Other (inc Escort/Worship)	Total
01 National Rail/Overground	84720	13480	13070	3160	2730	2450	119610
02 Underground/DLR	161210	30620	26650	7130	4290	2960	232860
03 Bus (+sch/wk bus/coach/tram)	90850	21450	111360	29000	12310	21190	286160
04 Taxi/Other	2900	1980	210	1280	440	380	7190
05 Car (+ van/lorry/mcycle)	65700	33000	37270	19070	17580	55650	228270
06 Walk/Cycle	102460	21360	157710	36260	26090	104700	448580
Total	507840	121890	346270	95900	63440	187330	1322670

## 1000-1600 (Inbound)

Mode	01 Usual workplace	02 Other work related	03 Education	04 Shopping and personal business	05 Leisure	06 Other (inc Escort/Worship)	Total
01 National Rail/Overground	4650	6090	5530	4140	4950	820	26180
02 Underground/DLR	9350	5970	8770	14180	6110	2780	47160
03 Bus (+sch/wk bus/coach/tram)	14490	9590	61050	124260	25500	16030	250920
04 Taxi/Other	0	350	230	8110	1460	160	10310
05 Car (+ van/lorry/mcycle)	21870	17060	21970	80140	26010	44250	211300
06 Walk/Cycle	19440	10290	125720	189030	85560	84660	514700
Total	69800	49350	223270	419860	149590	148700	1060570

## 1000-1600 (Outbound)

Mode	01 Usual workplace	02 Other work related	03 Education	04 Shopping and personal business	05 Leisure	06 Other (inc Escort/Worship)	Total
01 National Rail/Overground	4040	3380	1390	7570	14580	720	31680
02 Underground/DLR	18180	16890	12370	28500	19330	6510	101780
03 Bus (+sch/wk bus/coach/tram)	19110	10780	13460	136910	55010	18540	253810
04 Taxi/Other	440	960	470	4180	2810	280	9140
05 Car (+ van/lorry/mcycle)	13470	13370	1280	88460	50160	41490	208230
06 Walk/Cycle	17610	17740	13610	194730	98000	86810	428500
Total	72850	63120	42580	460350	239890	154350	1033140

## 1600-1900 (Inbound)

Mode	01 Usual workplace	02 Other work related	03 Education	04 Shopping and personal business	05 Leisure	06 Other (inc Escort/ Worship)	Total
01 National Rail/Overground	47670	13150	3250	1730	5940	160	71900
02 Underground/DLR	71560	22470	13950	8010	9800	690	126480
03 Bus (+sch/wk bus/coach/tram)	43100	10200	27010	46020	28110	6870	161310
04 Taxi/Other	0	810		2020	230	540	3600
05 Car (+ van/lorry/mcycle)	61100	30030	13340	35150	22650	34180	196450
06 Walk/Cycle	50550	16050	27080	82320	71050	26900	273950
Total	273980	92710	84630	175250	137780	69340	833690

## 1600-1900 (Outbound)

Mode	01 Usual workplace	02 Other work related	03 Education	04 Shopping and personal business	05 Leisure	06 Other (inc Escort/ Worship)	Total
01 National Rail/Overground	570	200	100	620	7890	880	10260
02 Underground/DLR	3270	4030	1390	4480	15980	1850	31000
03 Bus (+sch/wk bus/coach/tram)	3670	2970	3240	14400	18340	8470	51090
04 Taxi/Other	120	310		800	1190	0	2420
05 Car (+ van/lorry/mcycle)	8600	4300	2580	14670	32720	26870	89740
06 Walk/Cycle	4320	4030	1960	63450	61870	17120	152750
Total	20550	15840	9270	98420	137990	55190	337260

## 1900-2200 (Inbound)

Mode	01 Usual workplace	02 Other work related	03 Education	04 Shopping and personal business	05 Leisure	06 Other (inc Escort/ Worship)	Total
01 National Rail/Overground	10650	2160	760	2590	7510		23670
02 Underground/DLR	14890	3700	1740	2930	17460	1580	42300
03 Bus (+sch/wk bus/coach/tram)	10540	5340	2200	4840	26350	5740	55010
04 Taxi/Other	190	330		1650	3300	270	5740
05 Car (+ van/lorry/mcycle)	21750	7310	2330	19200	43750	20370	114710
06 Walk/Cycle	14510	5450	4530	38710	58310	10620	132130
Total	72530	24290	11560	69920	156680	38580	373560

## 1900-2200 (Outbound)

Mode	01 Usual workplace	02 Other work related	03 Education	04 Shopping and personal business	05 Leisure	06 Other (inc Escort/ Worship)	Total
01 National Rail/Overground	490	190		1090	2950		4720
02 Underground/DLR	1130	270			11210		12610
03 Bus (+sch/wk bus/coach/tram)	3040	1410		1050	15110	3750	24360
04 Taxi/Other	130	180			7600	0	7910
05 Car (+ van/lorry/mcycle)	3770	1320		6600	30020	13780	55490
06 Walk/Cycle	1200	720		23820	45210	7180	78130
Total	9760	4090		32560	112100	24710	183220

## 2200-0400 (Inbound)

Mode	01 Usual workplace	02 Other work related	03 Education	04 Shopping and personal business	05 Leisure	06 Other (inc Escort/ Worship)	Total
01 National Rail/Overground	1330	500		380	7920	0	10130
02 Underground/DLR	5960	4630	310	950	15140	570	27560
03 Bus (+sch/wk bus/coach/tram)	10170	1300	390	1620	21630	2370	37480
04 Taxi/Other	1710	0		750	14400	370	17230
05 Car (+ van/lorry/mcycle)	5940	4420	130	3230	34930	8910	57560
06 Walk/Cycle	4030	1090	160	6240	33020	5910	50450
Total	29140	11940	990	13170	127040	18130	200410

## 2200-0400 (Outbound)

Mode	01 Usual workplace	02 Other work related	03 Education	04 Shopping and personal business	05 Leisure	06 Other (inc Escort/ Worship)	Total
01 National Rail/Overground					180		180
02 Underground/DLR	0				920		920
03 Bus (+sch/wk bus/coach/tram)	800	480		350	1120		2750
04 Taxi/Other				270	1110		1380
05 Car (+ van/lorry/mcycle)	1960	780		770	2650	2770	8930
06 Walk/Cycle	210			3050	5670	4380	13310
Total	2970	1260		4440	11650	7150	27470

**30821 Charlton Riverside**  
**Residential Bus Trip Generation**

Residential units **771**

**Total Development Person Trips**

Time period	Total trip rates in	Total trip rates out	Total person in	Total person out	
0700-0800	0.040	0.299	30.8	230.3	868
0800-0900	0.046	0.503	35.7	388.1	
0900-1000	0.056	0.182	43.1	140.0	
1600-1700	0.093	0.069	71.7	53.5	638
1700-1800	0.171	0.072	131.8	55.3	
1800-1900	0.310	0.113	239.2	86.9	

**Total Person Trips**

Time Period	Total Person Trips from LTDS (Inner London)			Total Proposed Person Trips		
	Inbound	Outbound	Two - Way	Inbound	Outbound	Two - Way
0400-0700	10790	139000	149790	6	79	85
0700-1000	167300	1322670	1489970	110	758	868
1000-1600	1060570	1033140	2093710	600	585	1185
1600-1900	833690	337260	1170950	443	196	638
1900-2200	373560	183220	556780	211	104	315
2200-0400	200410	27470	227880	113	16	129

0.057%

**Bus Trips**

Time Period	Proportion of Total Person Trips that are Bus Trips*		Development Bus Trips		
	Inbound	Outbound	Inbound	Outbound	Two - Way
0400-0700	15%	24%	1	19	20
0700-1000	11%	22%	12	164	176
1000-1600	24%	25%	142	144	286
1600-1900	19%	15%	86	30	115
1900-2200	15%	13%	31	14	45
2200-0400	19%	10%	21	2	23

\* From London Travel Demand Survey 2010-2013 for Inner London

**Mode Split per Journey Purpose\***

Time Period	Inbound (destination)					Outbound (origin)				
	Work	Education	Shopping and personal business	Leisure	Other (inc Escort/Worship)	Work	Education	Shopping and personal business	Leisure	Other (inc Escort/Worship)
0400-0700	67%	0%	33%	0%	0%	89%	2%	3%	5%	1%
0700-1000	15%	1%	31%	13%	41%	39%	39%	10%	4%	7%
1000-1600	10%	24%	50%	10%	6%	12%	5%	54%	22%	7%
1600-1900	33%	17%	29%	17%	4%	13%	6%	28%	36%	17%
1900-2200	29%	4%	9%	48%	10%	18%	0%	4%	62%	15%
2200-0400	31%	1%	4%	58%	6%	47%	0%	13%	41%	0%

\* From London Travel Demand Survey 2010-2013 for Inner London

**Bus Trips per Journey Purpose**

Time Period	Inbound (destination)						Outbound (origin)					
	Work	Education	Shopping and personal business	Leisure	Other (inc Escort/Worship)	Total	Work	Education	Shopping and personal business	Leisure	Other (inc Escort/Worship)	Total
0400-0700	1	0	0	0	0	1	17	0	1	1	0	19
0700-1000	2	0	4	1	5	12	64	64	17	7	12	164
1000-1600	14	35	70	14	9	142	17	8	78	31	10	144
1600-1900	28	14	24	15	4	86	4	2	8	11	5	30
1900-2200	9	1	3	15	3	31	3	0	1	9	2	14
2200-0400	6	0	1	12	1	21	1	0	0	1	0	2

**30821 Charlton Riverside**

**Residential Bus Trip Distribution**

**Bus Trip / Journey Purpose**

Time Period	Inbound (destination)					Total
	Work	Education	Shopping & personal business	Leisure	Other (inc Escort/ Worship)	
0400-0700	1	0	0	0	0	1
0700-1000	2	0	4	1	5	12
1000-1600	14	35	70	14	9	142
1600-1900	28	14	24	15	4	86
1900-2200	9	1	3	15	3	31
2200-0400	6	0	1	12	1	21

Time Period	Outbound (origin)					Total
	Work	Education	Shopping & personal business	Leisure	Other (inc Escort/ Worship)	
0400-0700	17	0	1	1	0	19
0700-1000	64	64	17	7	12	164
1000-1600	17	8	78	31	10	144
1600-1900	4	2	8	11	5	30
1900-2200	3	0	1	9	2	14
2200-0400	1	0	0	1	0	2

**Journey Purpose - Work**

West	50%
East	30%

Time Period	Inbound			Outbound			Two-way		
	West	East	Total	West	East	Total	West	East	Total
0400-0700	0	0	1	9	5	17	9	5	14
0700-1000	1	1	2	32	19	64	33	20	53
1000-1600	7	4	14	8	5	17	15	9	24
1600-1900	14	8	28	2	1	4	16	10	26
1900-2200	4	3	9	1	1	3	6	3	9
2200-0400	3	2	6	0	0	1	4	2	6

**Journey Purpose - Education**

West	20%
East	50%

Time Period	Inbound			Outbound			Two-way		
	West	East	Total	West	East	Total	West	East	Total
0400-0700	0	0	0	0	0	0	0	0	0
0700-1000	0	0	0	13	32	64	13	32	45
1000-1600	7	17	35	2	4	8	8	21	30
1600-1900	3	7	14	0	1	2	3	8	11
1900-2200	0	1	1	0	0	0	0	1	1
2200-0400	0	0	0	0	0	0	0	0	0

### Journey Purpose - Shopping & Personal business

West 50%  
East 40%

Time Period	Inbound			Outbound			Two-way		
	West	East	Total	West	East	Total	West	East	Total
0400-0700	0	0	0	0	0	1	0	0	1
0700-1000	2	1	4	8	7	17	10	8	18
1000-1600	35	28	70	39	31	78	74	59	133
1600-1900	12	10	24	4	3	8	16	13	30
1900-2200	1	1	3	0	0	1	2	1	3
2200-0400	0	0	1	0	0	0	1	0	1

### Journey Purpose - Leisure

West 45%  
East 35%

Time Period	Inbound			Outbound			Two-way		
	West	East	Total	West	East	Total	West	East	Total
0400-0700	0	0	0	0	0	1	0	0	1
0700-1000	1	1	1	3	2	7	4	3	7
1000-1600	6	5	14	14	11	31	21	16	36
1600-1900	7	5	15	5	4	11	12	9	20
1900-2200	7	5	15	4	3	9	11	8	19
2200-0400	6	4	12	0	0	1	6	5	10

### Journey Purpose - Other

West 40%  
East 30%

Time Period	Inbound			Outbound			Two-way		
	West	East	Total	West	East	Total	West	East	Total
0400-0700	0	0	0	0	0	0	0	0	0
0700-1000	2	1	5	5	4	12	7	5	12
1000-1600	4	3	9	4	3	10	8	6	14
1600-1900	1	1	4	2	1	5	3	3	6
1900-2200	1	1	3	1	1	2	2	2	4
2200-0400	1	0	1	0	0	0	1	0	1

### Total Trips in Each Direction

Time Period	Inbound			Outbound			Two-way		
	West	East	Total	West	East	Total	West	East	Total
0400-0700	0	0	1	9	6	15	10	6	16
0700-1000	5	4	9	61	64	125	67	68	135
1000-1600	59	57	116	67	54	120.88	126	111	237
1600-1900	37	32	69	13	11	23.88	51	42	93
1900-2200	14	11	25	6	5	10.88	20	15	36
2200-0400	10	7	146	1	1	1.27	11	8	18

**30821 Charlton Riverside**

**Residential Bus Trip Distribution**

**Bus Trip / Journey Purpose**

Time Period	Inbound (destination)					Total
	Work	Education	Shopping & personal business	Leisure	Other (inc Escort/Worship)	
0400-0700	1	0	0	0	0	1
0700-1000	2	0	4	1	5	12
1000-1600	14	35	70	14	9	142
1600-1900	28	14	24	15	4	86
1900-2200	9	1	3	15	3	31
2200-0400	6	0	1	12	1	21

Time Period	Outbound (origin)					Total
	Work	Education	Shopping & personal business	Leisure	Other (inc Escort/Worship)	
0400-0700	17	0	1	1	0	19
0700-1000	64	64	17	7	12	164
1000-1600	17	8	78	31	10	144
1600-1900	4	2	8	11	5	30
1900-2200	3	0	1	9	2	14
2200-0400	1	0	0	1	0	2

**Journey Purpose - Work**

North	0%
South	20%

Time Period	Inbound			Outbound			Two-way		
	North	South	Total	North	South	Total	North	South	Total
0400-0700	0	0	1	0	3	17	0	4	4
0700-1000	0	0	2	0	13	64	0	13	13
1000-1600	0	3	14	0	3	17	0	6	6
1600-1900	0	6	28	0	1	4	0	6	6
1900-2200	0	2	9	0	1	3	0	2	2
2200-0400	0	1	6	0	0	1	0	1	1

**Journey Purpose - Education**

North	0%
South	30%

Time Period	Inbound			Outbound			Two-way		
	North	South	Total	North	South	Total	North	South	Total
0400-0700	0	0	0	0	0	0	0	0	0
0700-1000	0	0	0	0	19	64	0	19	19
1000-1600	0	10	35	0	2	8	0	13	13
1600-1900	0	4	14	0	1	2	0	5	5
1900-2200	0	0	1	0	0	0	0	0	0
2200-0400	0	0	0	0	0	0	0	0	0

**Journey Purpose - Shopping & Personal business**

North 0%  
 South 10%

Time Period	Inbound			Outbound			Two-way		
	North	South	Total	North	South	Total	North	South	Total
0400-0700	0	0	0	0	0	1	0	0	0
0700-1000	0	0	4	0	2	17	0	2	2
1000-1600	0	7	70	0	8	78	0	15	15
1600-1900	0	2	24	0	1	8	0	3	3
1900-2200	0	0	3	0	0	1	0	0	0
2200-0400	0	0	1	0	0	0	0	0	0

**Journey Purpose - Leisure**

North 0%  
 South 20%

Time Period	Inbound			Outbound			Two-way		
	North	South	Total	North	South	Total	North	South	Total
0400-0700	0	0	0	0	0	1	0	0	0
0700-1000	0	0	1	0	1	7	0	2	2
1000-1600	0	3	14	0	6	31	0	9	9
1600-1900	0	3	15	0	2	11	0	5	5
1900-2200	0	3	15	0	2	9	0	5	5
2200-0400	0	2	12	0	0	1	0	3	3

**Journey Purpose - Other**

North 0%  
 South 30%

Time Period	Inbound			Outbound			Two-way		
	North	South	Total	North	South	Total	North	South	Total
0400-0700	0	0	0	0	0	0	0	0	0
0700-1000	0	1	5	0	4	12	0	5	5
1000-1600	0	3	9	0	3	10	0	6	6
1600-1900	0	1	4	0	1	5	0	3	3
1900-2200	0	1	3	0	1	2	0	2	2
2200-0400	0	0	1	0	0	0	0	0	0

**Total Trips in Each Direction**

Time Period	Inbound			Outbound			Two-way		
	North	South	Total	North	South	Total	North	South	Total
0400-0700	0	0	0	0	4	4	0	4	3.99
0700-1000	0	3	3	0	39	39	0	41	41.26
1000-1600	0	26	26	0	23	23	0	49	48.54
1600-1900	0	16	16	0	6	6	0	22	22.26
1900-2200	0	6	6	0	3	3	0	9	9.31
2200-0400	0	4	0	0	0	0	0	5	4.60

## **Annex K**

### Traffic Flow Diagrams

30821 - Charlton Riverside

2016 Baseline AM Peak (08:00 - 09:00)

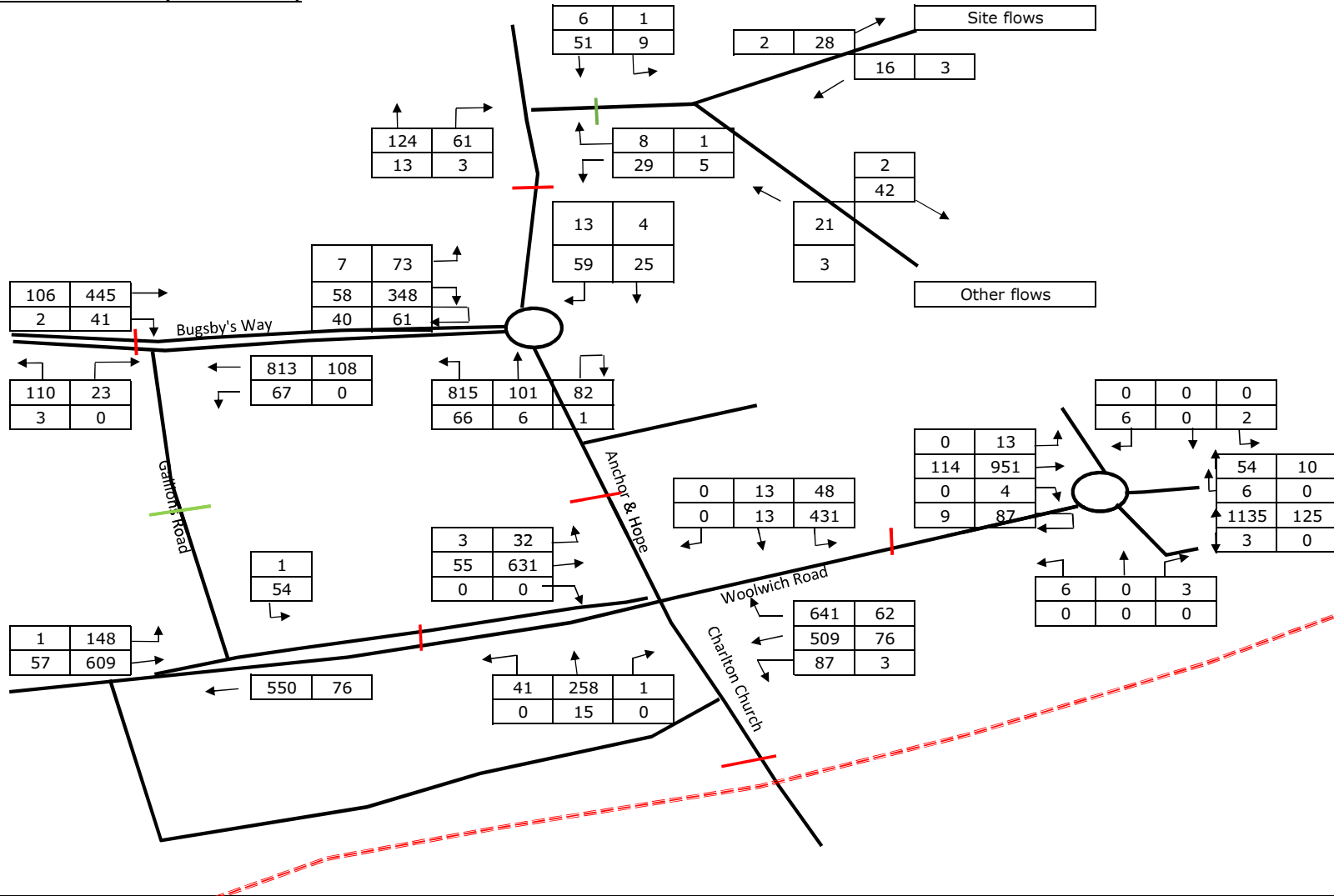

30821 - Charlton Riverside

2016 Baseline PM Peak (17:00 - 18:00)

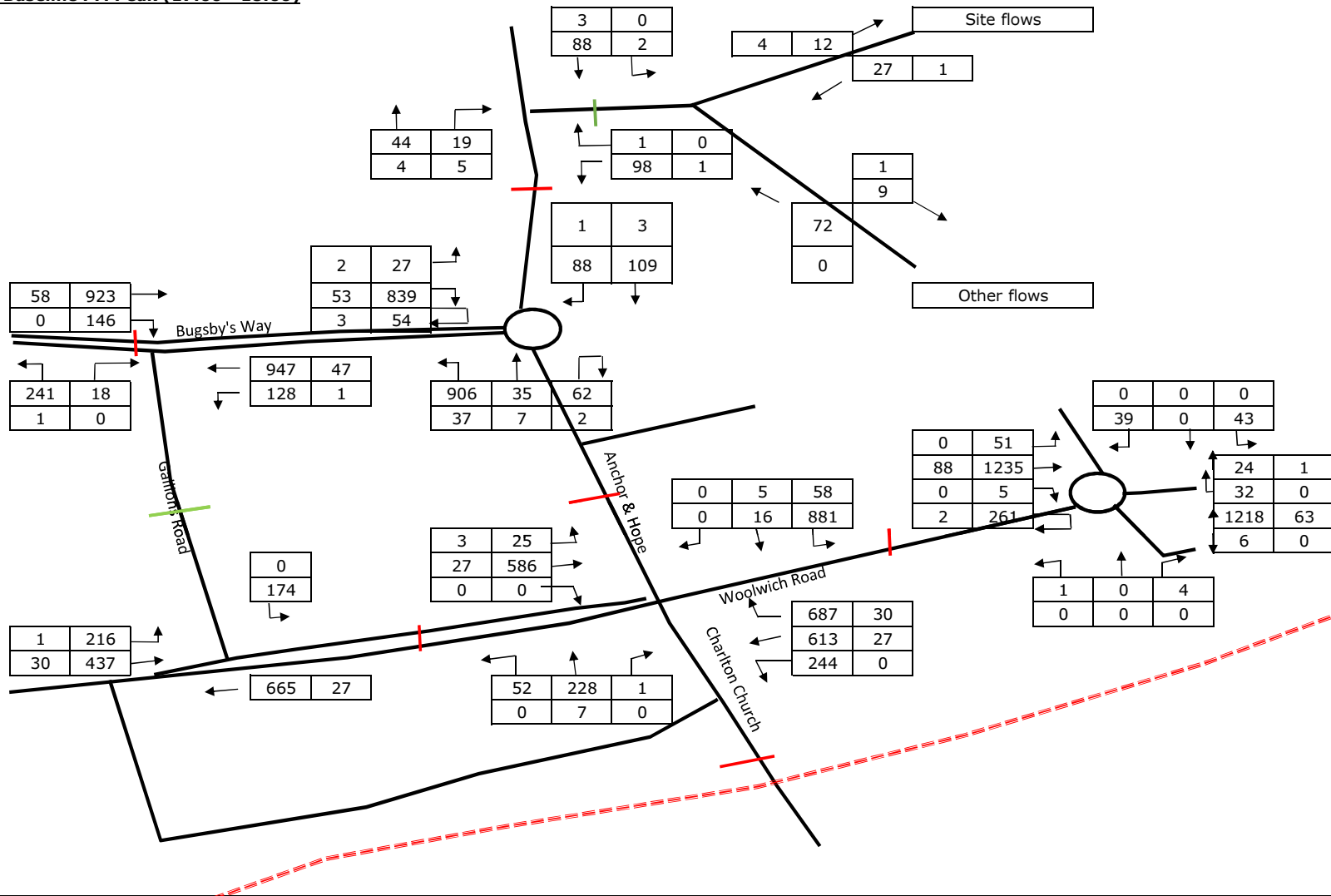

30821 - Charlton Riverside

Baseline Plus Proposed Development - AM Peak (08:00 - 09:00)

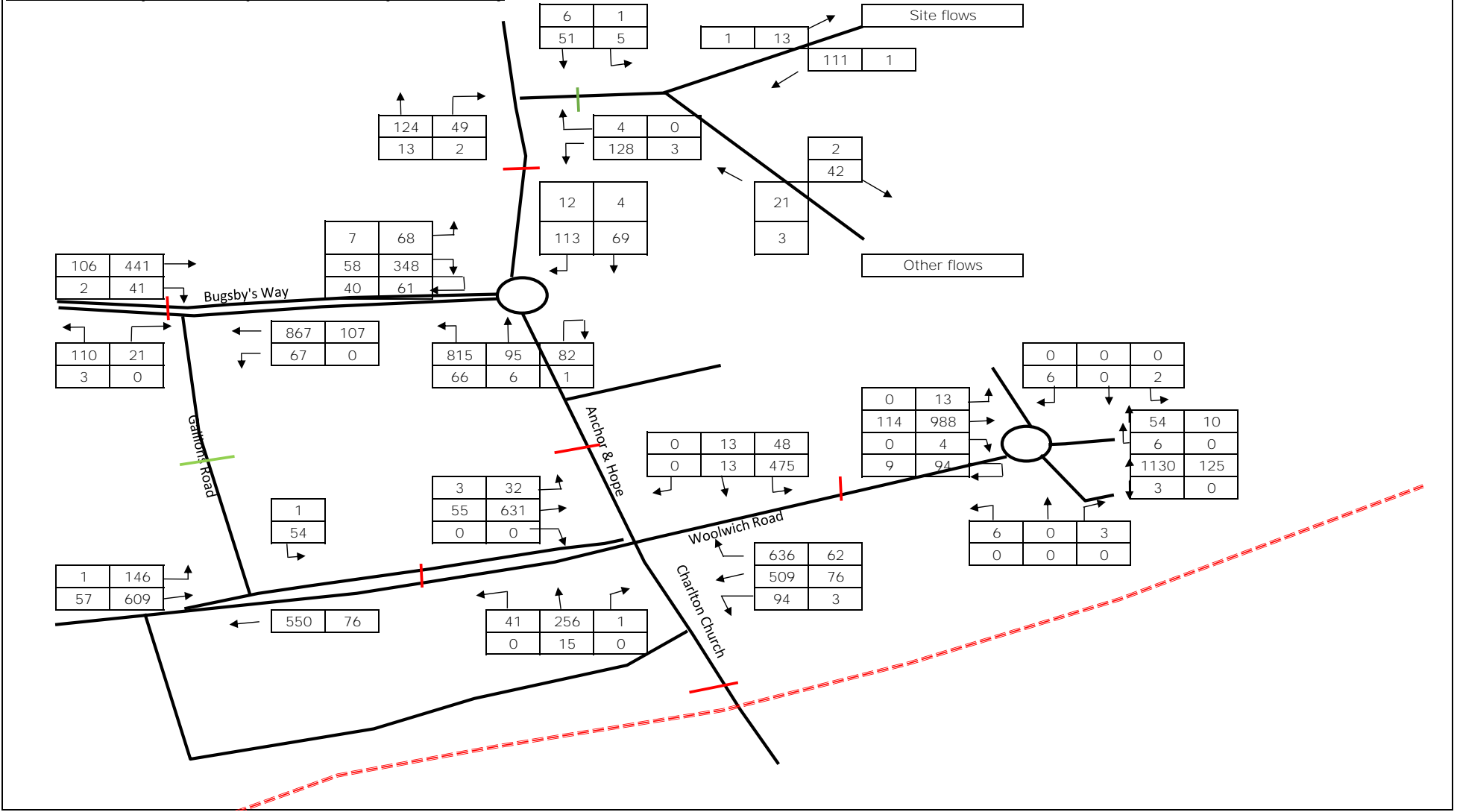

**30821 - Charlton Riverside**

**Baseline Plus Proposed Development - PM Peak (17:00 - 18:00)**

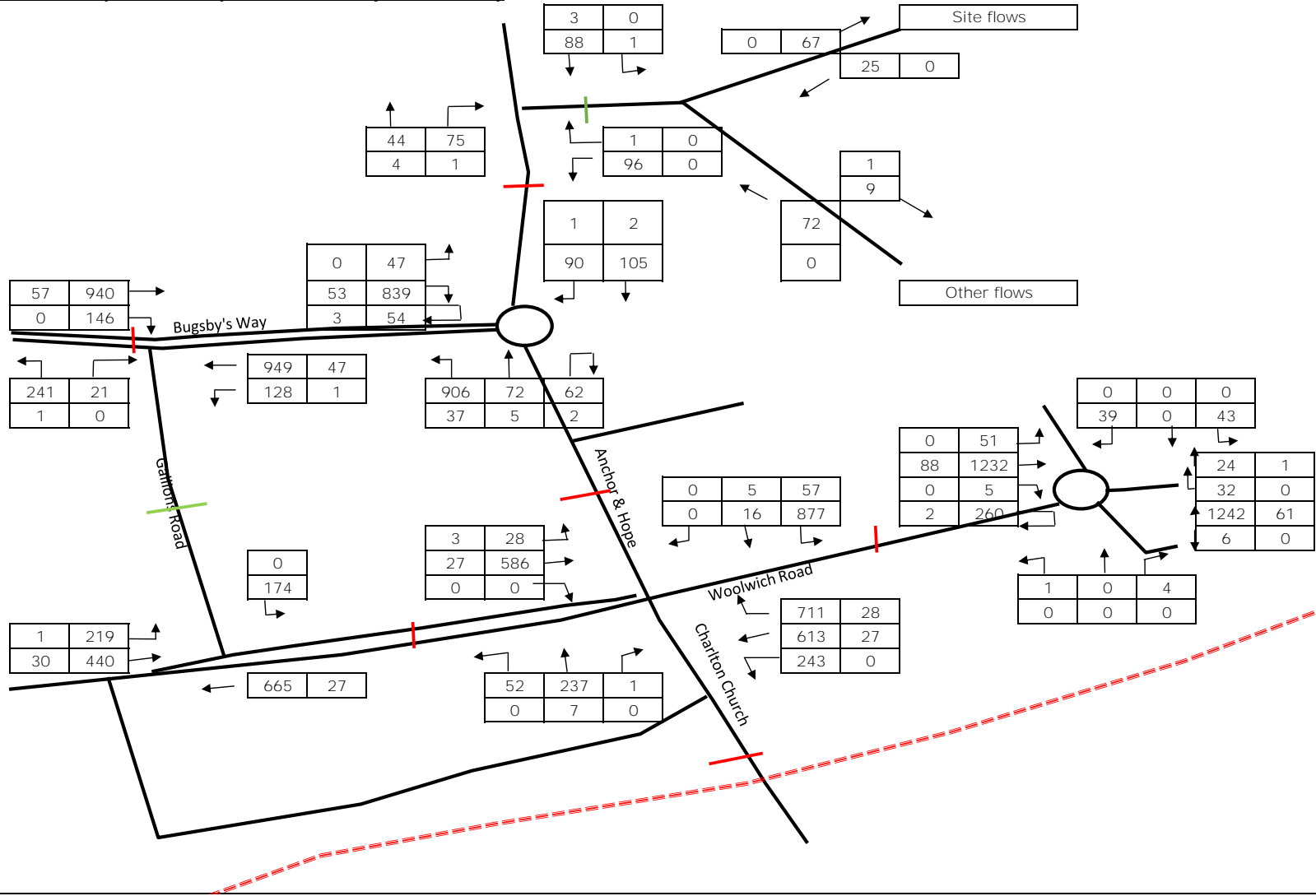

**30821 - Charlton Riverside**

**Baseline Plus Other Cumulative Developments - AM Peak - (08:00 - 09:00)**

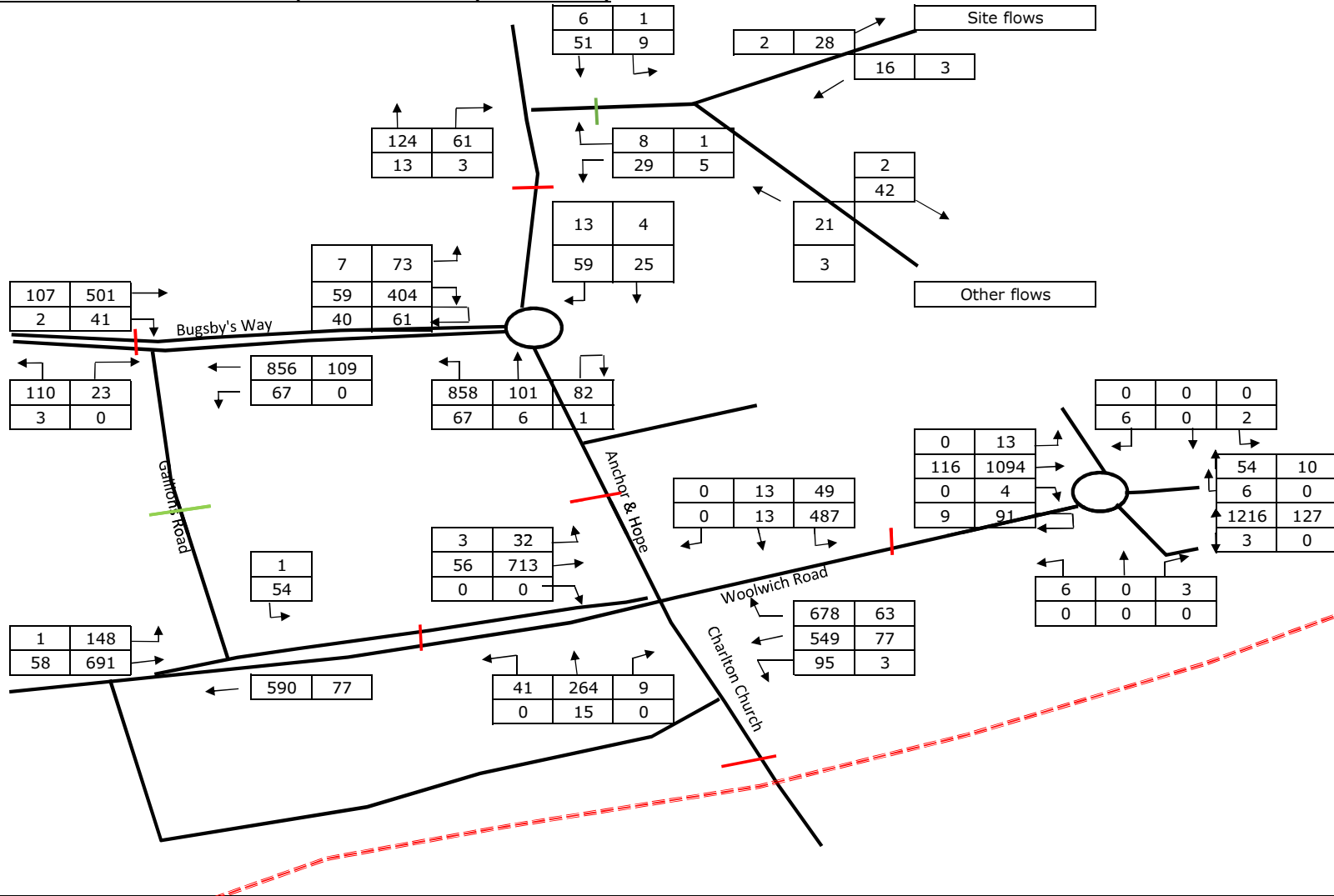

**30821 - Charlton Riverside**

**Baseline Plus Other Cumulative Developments - PM Peak - (17:00 - 18:00)**

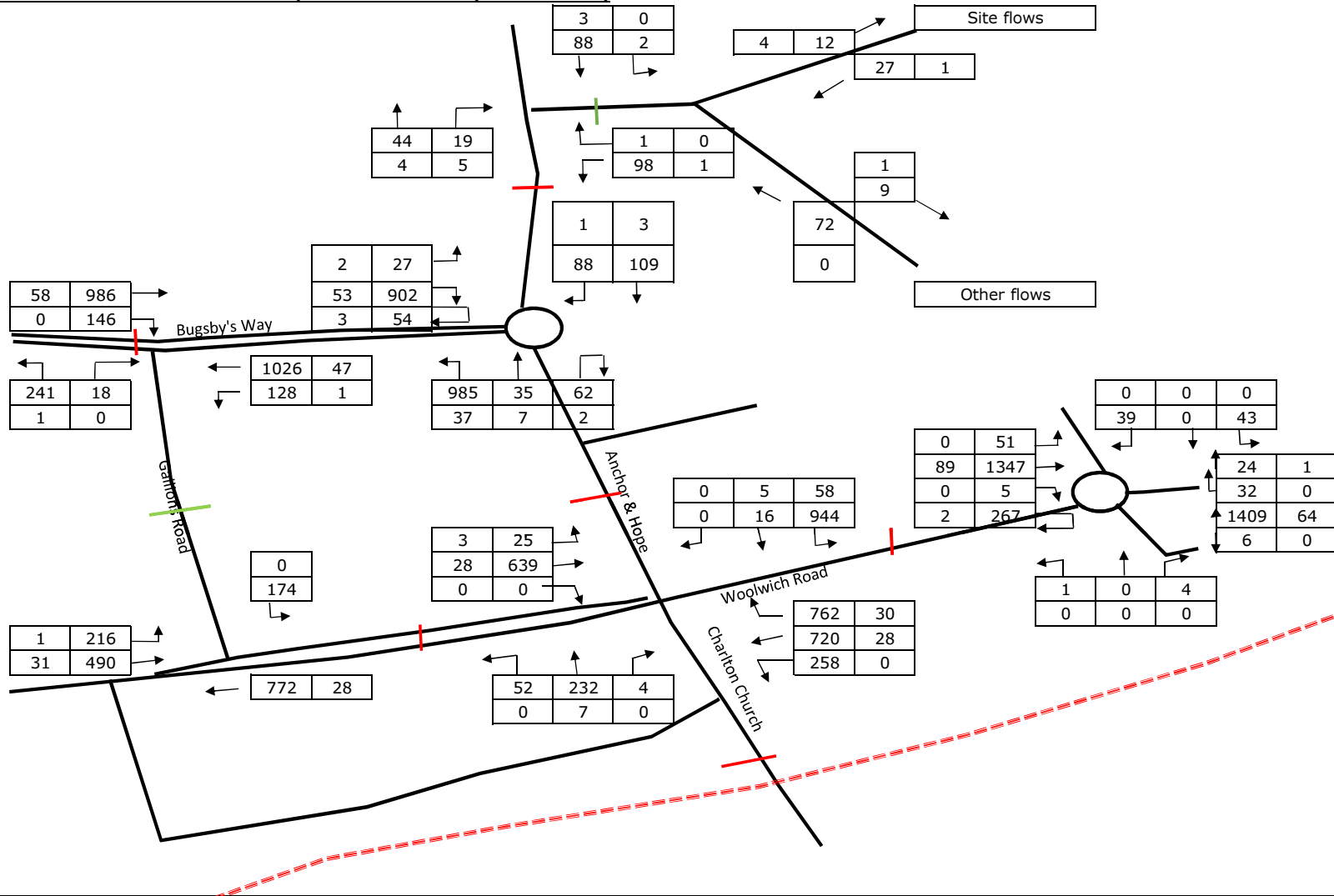

**30821 - Charlton Riverside**

**Cumulative Development Scenario - AM Peak - (08:00 - 09:00)**

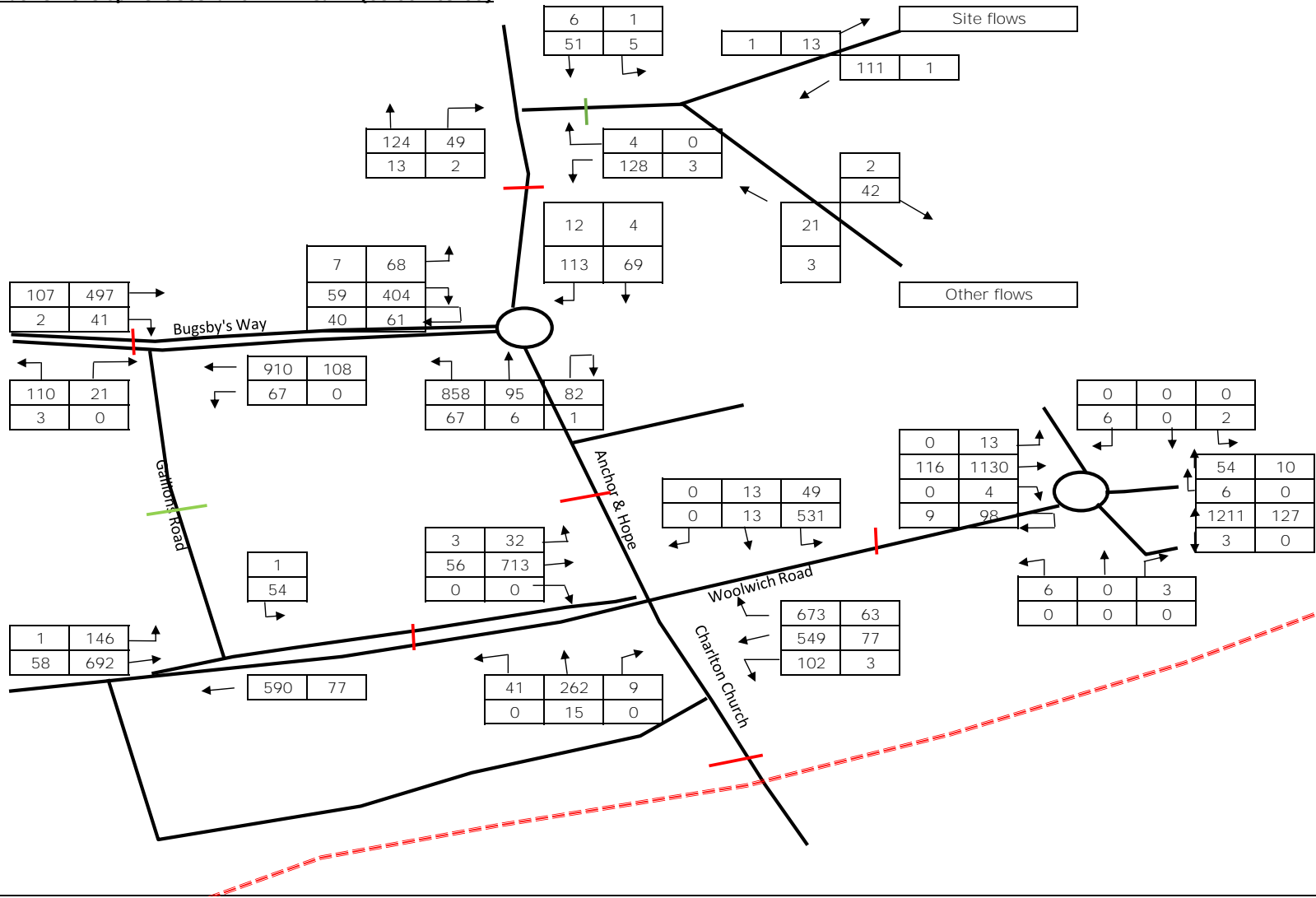

30821 - Charlton Riverside

Cumulative Development Scenario - PM Peak - (17:00 - 18:00)

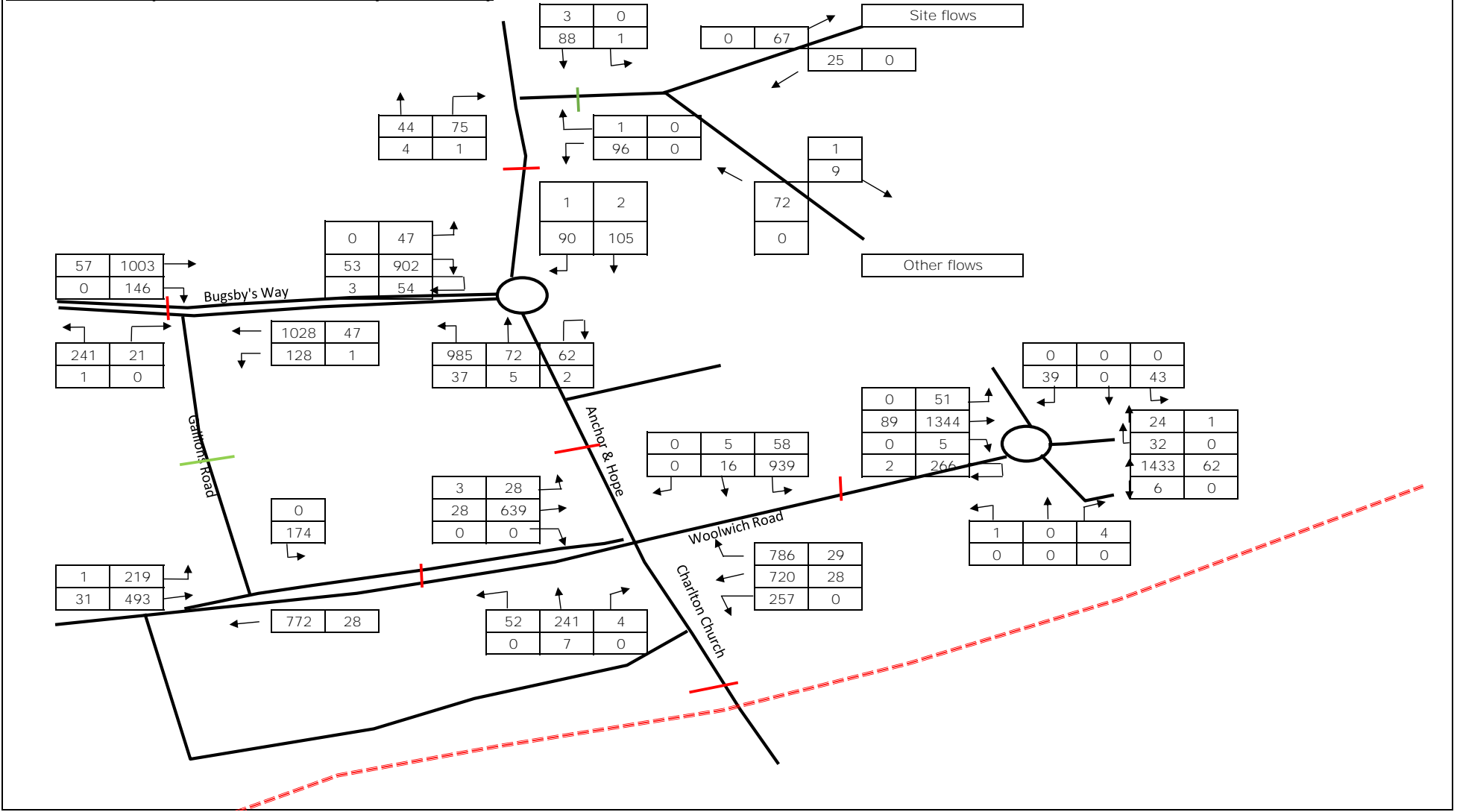

## **Annex L**

### Junctions Modelling Analysis Report



# Leopard Guernsey Anchor Propco Ltd

Anchor and Hope Lane Sites  
Junction Modelling Analysis

**30821/D007d**  
**December 2017**



## Contents

1	Introduction.....	1
2	Model Development .....	4
3	Assessment Scenarios.....	7
4	Evaluation of Model Results .....	8
5	Summary and Conclusion .....	15
6	Glossary.....	17

## Drawings

30821/AC/017 Locations of junction models

## Appendices

- A TfL Signal Timing Data
- B **Bugsby's Way/Gallions Road** LinSig Results
- C Gallions Road/Woolwich Road PICADY Results
- D Anchor and Hope Lane/Access Road PICADY Results
- E Anchor and Hope Lane North/**Bugsby's Way** ARCADY Results
- F Woolwich Road/Anchor and Hope Lane/Charlton Church Lane LinSig Results
- G Woolwich Road/Retail Park Access Road/Gallon Close ARCADY Results

# 1 INTRODUCTION

## 1.1 Background Context

1.1.1 Transport Planning Practice (TPP) has been appointed by Leopard Guernsey Anchor Propco Ltd to provide transport advice in relation to the proposed redevelopment of the VIP Trading Estate site located within the Charlton Riverside area of the Royal Borough of Greenwich (RBG).

1.1.2 The site sits within a currently, predominately industrial area between Woolwich Road (A206) and the southern bank of the River Thames. The main access to the site is from Anchor & Hope Lane which runs between Woolwich Road and Bugsby's Way. The site comprises two plots with a narrow strip connecting to Anchor & Hope Lane to the west and another to the north towards Thames Path. Figure 1.1 shows the location of the site in the context of the surrounding area.

**Figure 1.1 – Site location**

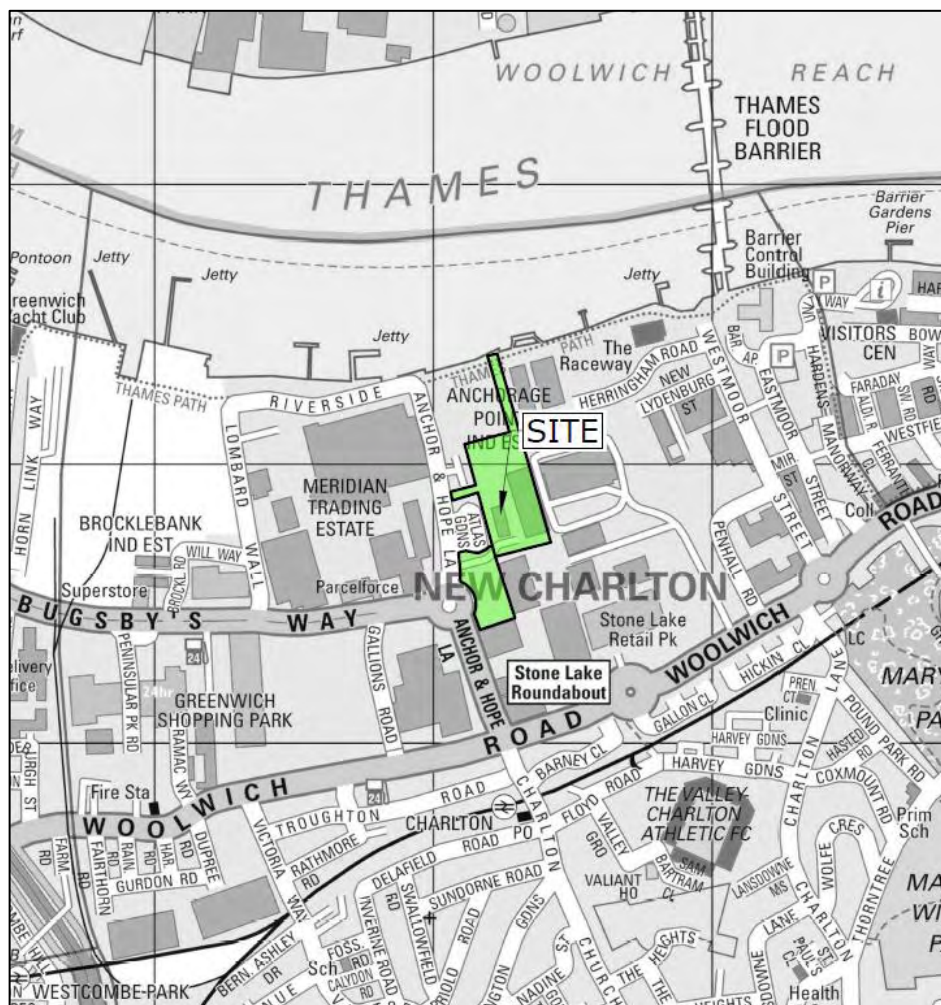

1.1.3 The proposed development will provide 771 residential units as well as flexible commercial space (A1-A3/B1/D1/D2). The opening year is expected to be 2023. The description of development is as follows:

1.1.4 The scheme will provide the following:

- 771 residential units, including extensive private gardens and roof terraces;
- 3,236 sqm of flexible commercial space;
- 496 sqm of ancillary residential facilities; and
- 337 sqm of community uses;

## **1.2 Report Structure**

1.2.1 The purpose of this report is to summarise the highway impact of the proposed development on the capacity of six existing junctions in the vicinity of the site. The junctions have been assessed using PICADY/ARCADY/LinSig modelling programmes. The junctions assessed are listed below:

1. **Bugsby's Way/Gallions Road signalised junction**
2. Gallions Road/Woolwich Road priority junction
3. Anchor and Hope Lane/Access Road priority junction
4. Anchor and Hope Lane North/**Bugsby's Way** roundabout
5. Woolwich Road/Anchor and Hope Lane/Charlton Church Lane signalised junction
6. Woolwich Road/Retail Park Access Road/Gallon Close roundabout

1.2.2 Figure 1.2 overleaf shows the locations of the modelled junctions.

**Figure 1.2 – Location of modelled junctions**

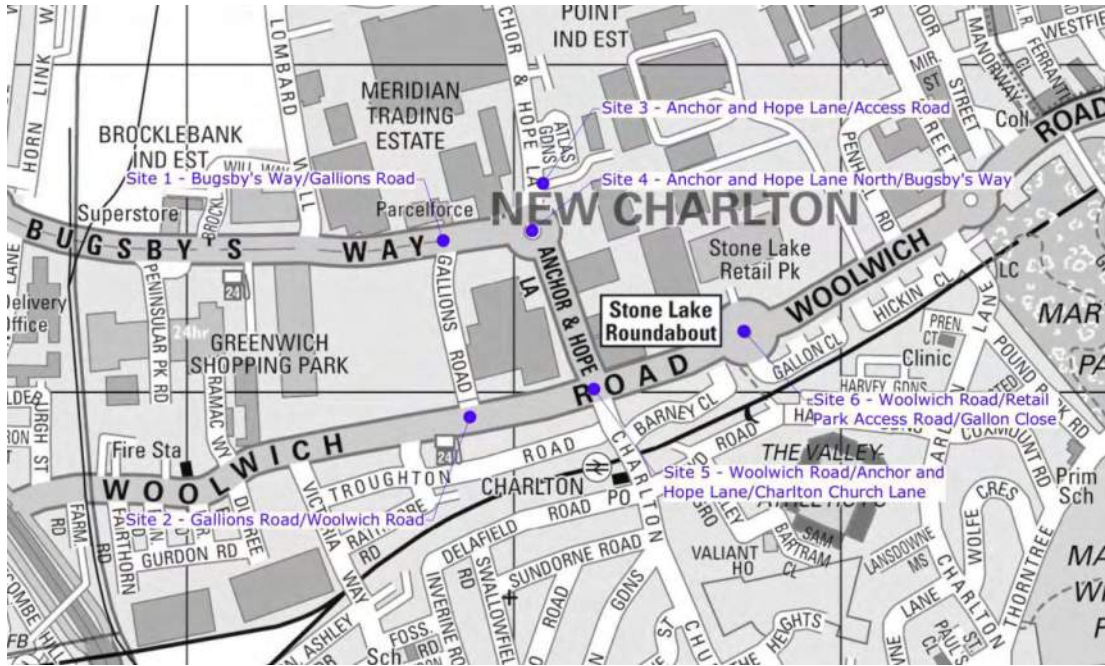

1.2.3 This report is structured as follows:

- **Chapter 2: Model Development** – summarises how the traffic models has been developed.
- **Chapter 3: Assessment Scenarios** – sets out the scenarios which have been used to assess the impact of the proposed Church development.
- **Chapter 4: Evaluation of Model Results** – evaluates the results from the PICADY/ARCADY/LinSig modelling work.

## **2 MODEL DEVELOPMENT**

### **2.1 Introduction**

2.1.1 This chapter summarises how the PICADY/ARCADY/LinSig models have been developed to assess the impact of the proposed Charlton Riverside development.

### **2.2 Assessed Junctions**

2.2.1 Vehicle access to the existing site is via Anchor & Hope Lane. As part of the proposed scheme, future trips will continue to use this access and this would be enhanced as part of the scheme and used as the main access.

### **2.3 PICADY Models**

2.3.1 PICADY models were constructed for the Gallions Road/Woolwich Road and Anchor and Hope Lane/Access Road priority junctions. The geometry of the existing junctions has been taken from ordnance survey mapping along with site observations and aerial photography.

2.3.2 The Gallions Road/Woolwich Road priority junction has three arms. The major arm is Woolwich Road. The minor arm is Gallions Road. There is a central island along Woolwich Road which prevents vehicles from both turning right into and right out of Gallions Road. Therefore this model will test any potential queue for left turning traffic from Gallions Road to Woolwich Road.

2.3.3 The Anchor and Hope Lane/Access Road priority junction has three arms. The major arm is Anchor and Hope Lane. The minor arm is the Access Road. All movements are permitted.

### **2.4 ARCADY models**

2.4.1 ARCADY models were constructed for the Anchor and Hope Lane North/**Bugsby's Way** and Woolwich Road/Retail Park Access Road/Gallon Close roundabout junctions. The geometry of the existing roundabouts have been taken from ordnance survey mapping along with site observations and aerial photography.

2.4.2 The Anchor and Hope Lane North/**Bugsby's Way** roundabout junction has three arms. The main flow on the roundabout comes from Anchor and Hope Lane which has two entry lanes from the south and three from the north.

2.4.3 The third arm is from **Bugsby's Way** which has three entry lanes from the west.

- 2.4.4 The Woolwich Road/Retail Park Access Road/Gallon Close roundabout junction has four arms. The main flow on the roundabout comes from Woolwich Road which joins the roundabout from both the east and west. Both the eastern and western arms have two entry lanes.
- 2.4.5 From the north the Retail Park Access has two entry lanes and from the south Gallions Close has one entry lane. Both these arms have significantly low flows.
- 2.4.6 All movements are permitted at both junctions.

## **2.5 LINSIG Models**

- 2.5.1 LinSig models were constructed for **Bugsby's Way/Gallions Road and Woolwich Road/Anchor and Hope Lane/Charlton Church Lane**. Saturation flows were provided for most of the arms on the two signalised junctions although due to the low flow on some arms it was not possible to give an accurate reading of all saturation flows. Therefore saturation flows have been taken using the RR67 prediction of saturation flows for road junctions. The geometry of the existing junctions has been taken from ordnance survey mapping along with site observations. The signal timings, staging and phasing have been based on Signal Timing data received from TfL, which is included in Appendix A.
- 2.5.2 **Bugsby's Way/Gallions Road is a three arm signalised junction. The major arm is Bugsby's Road which has three entry lanes from both the east and west.** The left turn lane approaching from the east turns into a bus lane upon exit, this mandates that all non-bus traffic in this lane must turn left into Gallions Road.
- 2.5.3 Gallions Road joins the junction from the south and has two entry lanes. All movements are permitted.
- 2.5.4 All arms of the junction have advanced cycle stops line (ASL) and this has been taken into account when modelling the junction.
- 2.5.5 The Woolwich Road/Anchor and Hope Lane/Charlton Church Lane is a four arm signalised junction. The main flow is on Woolwich Road which has four entry lanes from the east and two from the west. Anchor and Hope Lane joins the junction from the north and has three entry lanes. The two nearside lanes are for general traffic and both turn left with the offside lane for buses only. Charlton Church Lane joins from the south and has two entry lanes.

2.5.6 The latest version of LinSig (LinSig V3) has been used to assess the impact of the Charlton Riverside development and, where necessary, checks were undertaken and minor amendments made to refine the model operation.

### **3 ASSESSMENT SCENARIOS**

3.1.1 The traffic flow scenarios which have been used to assess the impact of the development on each junction are described as follows:

- 2016 Baseline
- Baseline Plus Proposed Development
- Baseline Plus Other Cumulative Developments
- Cumulative Development Scenario

3.1.2 Details of the trip generation and distribution for the proposed site are set out in the Transport Assessment along with the traffic flow diagrams for the above scenarios.

3.1.3 It has been agreed with TfL that background traffic growth is not applied and future traffic increases are related to committed, cumulative developments.

## **4 EVALUATION OF MODEL RESULTS**

### **4.1 Introduction**

4.1.1 This section provides an evaluation of the results from the modelling work.

### **4.2 Bugsby's Way/Gallions Road**

4.2.1 The LinSig results for the **Bugsby's Way/Gallions Road** junction are included in Appendix B.

#### ***2016 Baseline***

4.2.2 In the baseline scenario, the junction operates within capacity with maximum degree of saturations of 40% and 64% in the AM and PM peaks respectively. There are minimal queues across most of the arms with the longest queue being of around 8 PCUs. All queues are within stacking capacity and are clearing in the green period.

4.2.3 Comparisons have been made with the existing observed queues on-site and the queues within the model. Video surveys confirm that the queues are clearing within the green period.

#### ***Baseline Plus Proposed Development***

4.2.4 In the baseline + development scenario, the junction continues to perform within capacity with maximum degree of saturations of 42% and 64% in the AM and PM peaks respectively. There are minimal queues across most of the arms with the longest queue being of around 8 PCUs. All queues are within stacking capacity and are clearing in the green period.

#### ***Baseline Plus Other Cumulative Developments***

4.2.5 In the baseline + other cumulative development scenario, the junction continues to perform within capacity with maximum degree of saturations of 42% and 69% in the AM and PM peaks respectively. There are minimal queues across most of the arms with the longest queue being of around 9 PCUs. All queues are within stacking capacity and are clearing in the green period.

### ***Cumulative Development Scenario***

- 4.2.6 In the cumulative development scenario, the junction continues to perform within capacity with maximum degree of saturations of 44% and 79% in the AM and PM peaks respectively. There are minimal queues across most of the arms with the longest queue being of around 9 PCUs. All queues are within stacking capacity and are clearing in the green period.

## **4.3 Gallions Road/Woolwich Road**

4.3.1 The PICADY results for the Gallions Road/Woolwich Road junction are included in Appendix C. As mentioned in paragraph 2.3.2 this model will only test the left turning vehicles from Gallions Road as Woolwich Road has a central island prohibiting right turns.

### ***2016 Baseline***

4.3.2 In the baseline scenario, the Gallions Road arm operates within capacity with maximum RFCs of 11% and 32% in the AM and PM peak respectively. There is a minimal queue of one vehicle or less.

4.3.3 Comparisons have been made with the existing observed queues on-site and the queues within the model. Video surveys confirm that there is minimal queuing, as would be expected with a junction of this layout and flow.

### ***Baseline Plus Proposed Development***

4.3.4 In the baseline + development scenario, the Gallions Road arm operates within capacity with maximum RFCs of 11% and 32% in the AM and PM peak respectively. There is a minimal queue of one vehicle or less.

### ***Baseline Plus Other Cumulative Developments***

4.3.5 In the baseline + other cumulative development scenario, the Gallions Road arm operates within capacity with maximum RFCs of 11% and 33% in the AM and PM peak respectively. There is a minimal queue of one vehicle or less.

### ***Cumulative Development Scenario***

4.3.6 In the cumulative development scenario, the Gallions Road arm operates within capacity with maximum RFCs of 11% and 33% in the AM and PM peak respectively. There is a minimal queue of one vehicle or less.

## **4.4 Anchor and Hope Lane/Access Road**

4.4.1 The PICADY results for the Anchor and Hope Lane/Access Road junction are included in Appendix D. This junction is where the development will take access and we would expect to see an increase to RFC on the minor arm (Access Road).

### ***2016 Baseline***

4.4.2 In the baseline scenario, the junction operates within capacity with maximum RFCs of 11% and 15% in the AM and PM peaks respectively. There are minimal queues of one vehicle or less on all arms.

4.4.3 Comparisons have been made with the existing observed queues on-site and the queues within the model. Video surveys confirm that there is minimal queuing on the minor arm (Access Road) and on right-turning vehicles into the minor arm.

### ***Baseline Plus Proposed Development***

4.4.4 In the baseline + development scenario, the junction continues to perform within capacity with maximum RFCs of 19% and 15% in the AM and PM peaks respectively. There are minimal queues of one vehicle or less on all arms.

### ***Baseline Plus Other Cumulative Developments***

4.4.5 In the baseline + other cumulative development scenario, the junction performs within capacity with maximum RFCs of 11% and 15% in the AM and PM peaks respectively. There are minimal queues of one vehicle or less on all arms.

### ***Cumulative Development Scenario***

4.4.6 In the cumulative development scenario, the junction continues to perform within capacity with maximum RFCs of 19% and 15% in the AM and PM peaks respectively. There are minimal queues of one vehicle or less on all arms.

## **4.5 Anchor and Hope Lane North/Bugsby's Way**

4.5.1 The ARCADY results for the Anchor and Hope Lane North/Bugsby's Way roundabout are included in Appendix E.

### ***2016 Baseline***

4.5.2 In the baseline scenario, the junction operates within capacity with maximum RFCs of 51% and 54% in the AM and PM peaks respectively. There are minimal queues 1.2 vehicles or less on all arms.

4.5.3 Comparisons have been made with the existing observed queues on-site and the queues within the model. Video surveys confirm that there is minimal queuing on all arms.

### ***Baseline Plus Proposed Development***

4.5.4 In the baseline + development scenario, the junction continues to perform within capacity with maximum RFCs of 51% and 56% in the AM and PM peaks respectively. There are minimal queues 1.3 vehicles or less on all arms.

### ***Baseline Plus Other Cumulative Developments***

4.5.5 In the baseline + other cumulative development scenario, the junction performs within capacity with maximum RFCs of 53% and 58% in the AM and PM peaks respectively. There are minimal queues 1.4 vehicles or less on all arms.

### ***Cumulative Development Scenario***

4.5.6 In the cumulative development scenario, the junction continues to perform within capacity with maximum RFCs of 54% and 60% in the AM and PM peaks respectively. There are minimal queues 1.5 vehicles or less on all arms.

## **4.6 Woolwich Road/Anchor and Hope Lane/Charlton Church Lane**

4.6.1 The LinSig results for the Woolwich Road/Anchor and Hope Lane/Charlton Church Lane junction are included in Appendix F.

### ***2016 Baseline***

4.6.2 In the baseline scenario, the junction operates within capacity with maximum degree of saturations of 73% and 68% in the AM and PM peaks respectively. There are minimal queues across most of the arms with the longest queue being of around 12 PCUs. All queues are within stacking capacity and are clearing in the green period.

4.6.3 Comparisons have been made with the existing observed queues on-site and the queues within the model. Video surveys confirm that the queues are clearing within the green period.

### ***Baseline Plus Proposed Development***

4.6.4 In the baseline + development scenario, the junction continues to perform within capacity with maximum degree of saturations of 73% and 70% in the AM and PM peaks respectively. There are minimal queues across most of the arms with the longest queue being of around 12 PCUs. All queues are within stacking capacity and are clearing in the green period.

### ***Baseline Plus Other Cumulative Developments***

4.6.5 In the baseline + other cumulative development scenario, the junction continues to perform within capacity with maximum degree of saturations of 78% and 74% in the AM and PM peaks respectively. There are minimal queues across most of the arms with the longest queue being of around 15 PCUs. All queues are within stacking capacity and are clearing in the green period.

### ***Cumulative Development Scenario***

4.6.6 In the cumulative development scenario, the junction continues to perform within capacity with maximum degree of saturations of 78% and 74% in the AM and PM peaks respectively. There are minimal queues across most of the arms with the longest queue being of around 15 PCUs. All queues are within stacking capacity and are clearing in the green period.

## **4.7 Woolwich Road/Retail Park Access Road/Gallon Close**

4.7.1 The ARCADY results for the Woolwich Road/Retail Park Access Road/Gallon Close roundabout are included in Appendix G.

### ***2016 Baseline***

4.7.2 In the baseline scenario, the junction operates within capacity with maximum RFCs of 59% and 64% in the AM and PM peaks respectively. There are minimal queues 2.3 vehicles or less on all arms.

4.7.3 Comparisons have been made with the existing observed queues on-site and the queues within the model. Video surveys confirm that there is minimal queuing on all arms.

### ***Baseline Plus Proposed Development***

4.7.4 In the baseline + development scenario, the junction continues to perform within capacity with maximum RFCs of 59% and 70% in the AM and PM peaks respectively. There are minimal queues 2.3 vehicles or less on all arms.

### ***Baseline Plus Other Cumulative Developments***

4.7.5 In the baseline + other cumulative development scenario, the junction performs within capacity with maximum RFCs of 63% and 75% in the AM and PM peaks respectively. There are minimal queues 3 vehicles or less on all arms.

### ***Cumulative Development Scenario***

4.7.6 In the cumulative development scenario, the junction continues to perform within capacity with maximum RFCs of 63% and 75% in the AM and PM peaks respectively. There are minimal queues 3 vehicles or less on all arms.

## 5 SUMMARY AND CONCLUSION

### *Summary*

- 5.1.1 TPP has been appointed by Leopard Guernsey Anchor Propco Ltd to provide transport advice in relation to the proposed redevelopment of the VIP Trading Estate site located within the Charlton Riverside area of the RBG.
- 5.1.2 The purpose of this report is to assess the impact of the proposed development on the capacity of six existing junctions in the vicinity of the site. These junctions are listed below:
1. **Bugsby's Way/Gallions Road signalised junction**
  2. Gallions Road/Woolwich Road priority junction
  3. Anchor and Hope Lane/Access Road priority junction
  4. Anchor and Hope Lane North/**Bugsby's Way** roundabout
  5. Woolwich Road/Anchor and Hope Lane/Charlton Church Lane signalised junction
  6. Woolwich Road/Retail Park Access Road/Gallon Close roundabout
- 5.1.3 The traffic flow scenarios which have been used to assess the impact of the development on each junction are described as follows:
- 2016 Baseline
  - Baseline Plus Proposed Development
  - Baseline Plus Other Cumulative Developments
  - Cumulative Development Scenario
- 5.1.4 The baseline situation models have been compared and validated with the observed queues. Video surveys confirm that the models are in-line with what has been observed on-site.
- 5.1.5 Saturation flows for the signalised junctions have been taken using the RR67 prediction of saturation flows for road junctions.

## **Conclusion**

- 5.1.6 The above assessment confirms that the proposed development can be accommodated within the highway network and would not have a significant adverse impact on the capacity of critical links. Therefore no mitigation will be required to improve junction capacity to accommodate the proposed development.

## 6 GLOSSARY

- PICADY - (Priority Intersection Capacity and DelaY) is a software program for modelling the queue/delay at three and four arm priority junctions.
- ARCADY - (Assessment of Roundabout Capacity And DelaY) is a software program for modelling the queue and delay at roundabouts.
- LinSig - LinSig is a software tool developed by JCT Consultancy which allows traffic engineers to model traffic signals and their effect on capacity and queuing. As well as modelling the effects of traffic signals LinSig also optimises signal timings to reduce delay or increase capacity at a junction.
- PCU – Passenger Car Unit.
- RFC – Ratio of demand flow to capacity.
- Degree of Saturation - the ratio of demand flow to the maximum flow which can be passed through the intersection from a particular approach.
- Saturation flow - maximum average flows from a queue of traffic.
- RR67 – publication published in 1986 which discusses the prediction of saturation flows for road junctions controlled by traffic signals.

# Appendices

# **Appendix A**

## **TfL Signal Timing Data**



# TfL Street Management

## Timing Sheets

## UTC Micro

London Borough Of	Grid Reference	UTC Cell	Bt Line No	Issue	Date Implemented	Initials	Site Number
GREENWICH	541120/178502	SOUT	LLLS1304053	41	19-APR-2016	ALDRIDGED	06/000031/U
Address							
A206 WOOLWICH ROAD - CHARLTON CHURCH LANE - ANCHOR AND HOPE LANE							
PDU Rate	Controller Installed Date	Engineer Responsible	Linking				
68	22-MAR-2006	FC_PC					
Computer	Control	Control	Concentr				
Takeover Date	Grp/Reg	Grp	Subgrp	Subgrp	Prom Number	Firmware	Controller Type
30-JUL-2009		432	06/000031/U		EM67690V6	PB800-24	STCL T800 MK 1 UTC Cntr, Integral Facilities

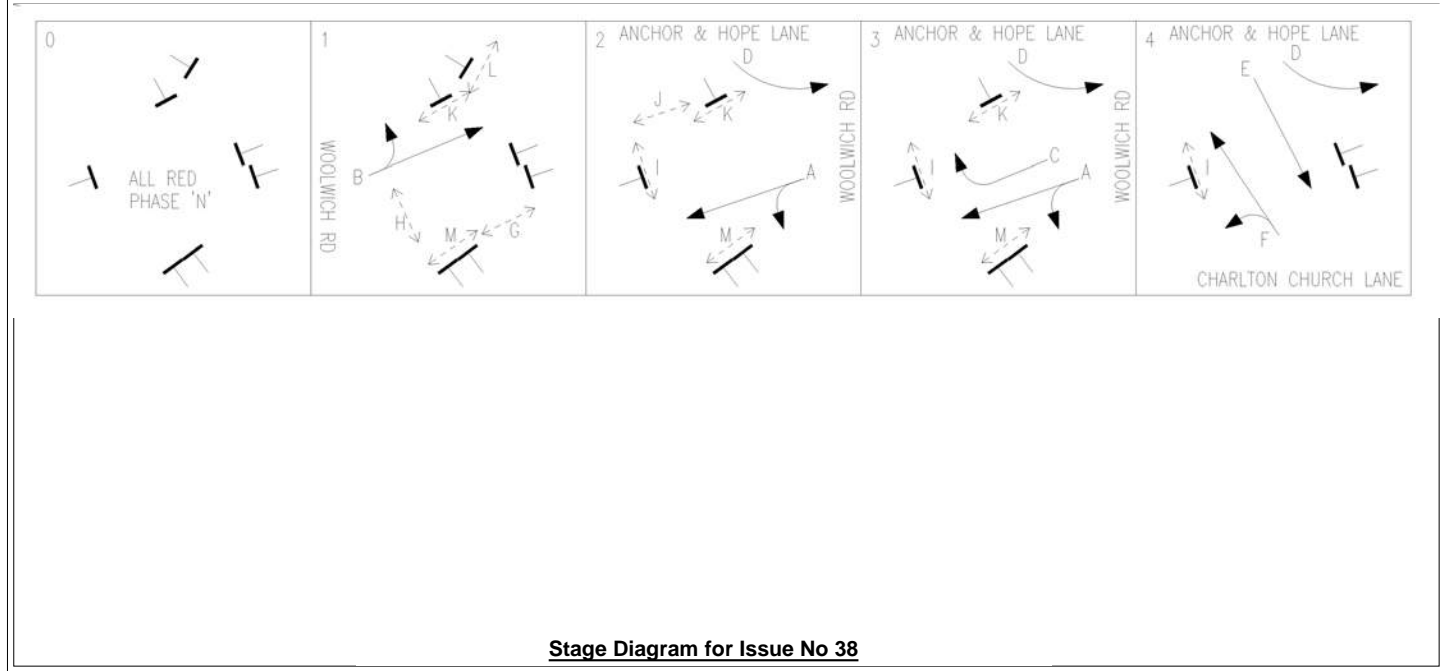

TFL Drg No PRO/06/031/07      HI Signal YES  
 Sig Drg No PRO/06/031/02A      Dimming 160    Volts

UTC - Control and Reply bits																															
CONTROL																															
01	02	03	04	05	06	07	08	09	10	11	12	13	14	15	16	17	18	19	20	21	22	23	24	25	26	27	28	29	30	31	32
1F1	#1F2	1F3	#1F4	1DX											1TS	1EP															
REPLY																															
01	02	03	04	05	06	07	08	09	10	11	12	13	14	15	16	17	18	19	20	21	22	23	24	25	26	27	28	29	30	31	32
1G1	1G2	1G3	1G4	1JD	1JL	1RF1	1RF2	1RT	1EC	1SB0	1SB1	1SB2	1SB3	1SB4	1PR0	1PR1															

**Please refer to Spec for the following :-**

**\* Total no of Detectors - 41 (limited to 36)**



Phase Timings						
Phase	Min	Ext	Max	Ped Black	Phase Type	Alternative Maximums
A	7	.4	30		T	
B	7	.4	30		T	
C	7	.4	20		T	
D	7	.4	10		T	
E	7	.4	7		T	
F	7	.4	20		T	
G	6			4	P	
H	6			4	P	
I	6			4	P	
J	6			4	P	
K	6			3	P	
L	6			5	P	
M	6			4	P	
N	3				D	

Issue	Site Number
41	06/000031/U

Phase Intergreens

		To Phase													
		A	B	C	D	E	F	G	H	I	J	K	L	M	N
From Phase	A					5	7	7	9						3
	B			5	9	8	5			6	10				3
	C		7			5	5				11				3
	D		5										5		3
	E	7	5	6				9				5			3
	F	5	7	5					8		10			5	3
	G	10				10									4
	H	9					9								4
	I		10												4
	J		9	9			9								4
	K						8								3
	L					11									5
	M						10								4
	N	2	2	2	2	2	2	2	2	2	2	2	2	2	2



# TfL Street Management

## Timing Sheets

UTC Micro

Mode Priority	CLF PLAN1		CLF PLAN2		CLF PLAN3		CLF PLAN8		Issue	Site Number
	Time Of Day	Day	Time Of Day	Day	Time Of Day	Day	Time Of Day	Day	41	06/000031/U
UTC										
Hand Control										
Manual Select	05:30	9	10:00	9	15:30	9	19:00	9		
Hurry (1)			07:00	0						
Hurry (2)			07:00	1						
VA										
CLF										
Fix Time										
Bus Priority										
	Cycle Time		Cycle Time		Cycle Time		Cycle Time			
	120		112		120		88			

Phase Delays				Phase Delays				Phase Delays				Phase Delays			
Stage From	Stage To	Phase Associated	Delay Period	Stage From	Stage To	Phase Associated	Delay Period	Stage From	Stage To	Phase Associated	Delay Period	Stage From	Stage To	Phase Associated	Delay Period
1	2	B	1	2	4	A	3	3	4	C	5				
1	3	B	2	3	1	A	1	4	1	D	5				
1	4	B	2	3	1	C	3	4	1	E	1				
2	1	A	1	3	1	D	5	4	1	F	1				
2	1	D	5	3	4	A	3	4	3	F	2				

DET	Function	Phase	DET	Function	Phase	DET	Function	Phase	DET	Function	Phase
ASMVD2	CEX	A	PB P10	CAL	M	PB P21	CAL	L	PB P9	CAL	M
BSMVD15	CEX	B	PB P11	CAL	H	PB P23	CAL	L	PB P18	CAL	K
CSMVD3	CEX	C	PB P12	CAL	H	iSB0	BUS	A	PB P22	CAL	L
DSMVD21	CEX	D	PB P14	CAL	I	iSB1	BUS	B	PB P25	CAL	H
ESMVD20	CEX	E	PB P15	CAL	I	iSB2	BUS	D	PB P26	CAL	I
FSMVD10	CEX	F	PB P16	CAL	J	iSB3	BUS	E	PB P27	CAL	J
PB P6	CAL	G	PB P17	CAL	J	iSB4	BUS	N	iSB5		
PB P7	CAL	G	PB P19	CAL	K	AIRD P3	CAL	A	SD0	SCT	A
PB P8	CAL	M	PB P20	CAL	K	PB P24	CAL	G	SD1	SCT	A

Issue	Historical Amendments
41	TIMING CHANGE - PUSH BUTTON ON POLE 18 MOVED TO NEW DFM GROUP WITH ACTIVE TIME = 30 MINS & INACTIVE TIME = 254 HOURS. 19-APR-2016 ALDRIDGED
40	NEW PROM (TFL SPEC ISSUE 14) INSTALLED & UTC COMMISSIONED FOR ADDITIONAL SHORT POLE & PBU 10-MAR-2016 WEBSTERG
39.2	SNAGGING COMPLETED. TACTILES INSTALLED. 08-JAN-2016. WEBSTERG
39.1	MVD & IRD REPLACED AFTER FAULT - EQUIPMENT VERSION UPLOADED 12-OCT-2015 WORBEYD
39	NEW PROM (TFL SPEC ISSUE 13) INSTALLED & UTC COMMISSIONED. ADDITIONAL SHORT POLES WITH PUSH BUTTONS & TACTILES INSTALLED. 05-OCT-2015 WEBSTERG
38.2	iSB5 ADDED P CALLAWAY 25-DEC-2014
38.1	UTC LINE NO. DETAILS UPDATED. 24-DEC-2014 DTA_BM
38	NEW PROM (TFL SPEC ISSUE 11) INSTALLED & UTC COMMISSIONED FOR REVISED SIGNAL LAYOUT ACROSS CHARLTON CHURCH LANE.

Remarks
Version No 14
Linking C.L.F.
Comments TFL SPEC ISSUE 14. iBUS LINE NO. 020 8269 2840. UTC REPLY BITS: 17-1PR1.
Det Strategy SMVDs - IRD - PUSHBUTTONS / TACTILES - SCOOT LOOPS - iBUS (TSN 1571)
Amendment TIMING CHANGE - PUSH BUTTON ON POLE 18 MOVED TO NEW DFM GROUP WITH ACTIVE TIME = 30 MINS & INACTIVE TIME = 254 HOURS. 19-APR-2016 ALDRIDGED



# TfL Street Management

## Timing Sheets

## UTC Micro

London Borough Of	Grid Reference	UTC Cell	Bt Line No	Issue	Date Implemented	Initials	Site Number
GREENWICH	540898/178732	SOUT	IPOTU	2	10-NOV-2015	DAHERH	06/000328/U

Address  
BUGSBY'S WAY - GALLIONS ROAD

PDU Rate	Controller Installed Date	Engineer Responsible	Linking
67	06-JAN-2015	DAHERH	06/000828/

Computer	Control	Control	Concentr	Prom Number	Firmware	Controller Type
Takeover Date	Grp/Reg	Grp	Subgrp	Subgrp		
26-AUG-2015					EM31387 V3	PB801-13
STCL ELV T900 MK 1 UTC Semi VA Controller						

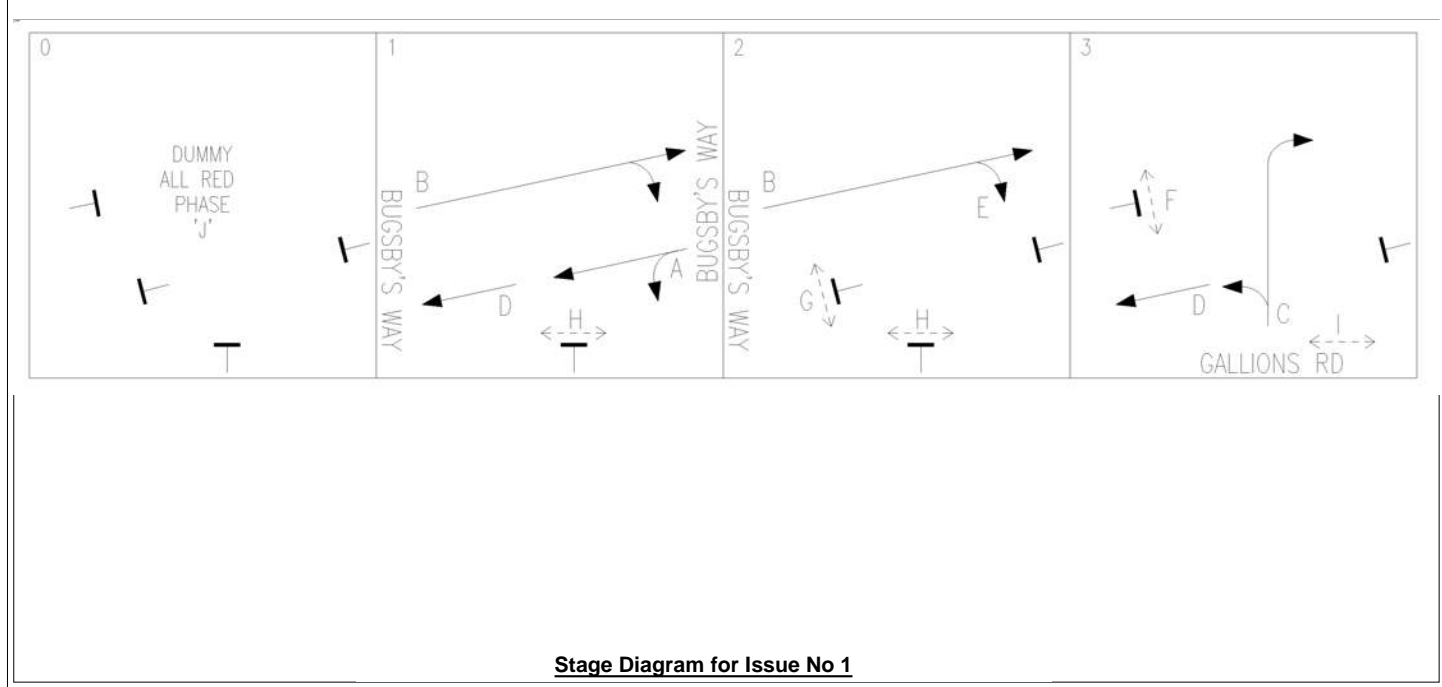

TFL Drg No                      HI Signal NO  
 Sig Drg No PRO/06/000328/01      Dimming 28      Volts

UTC - Control and Reply bits																															
CONTROL																															
01	02	03	04	05	06	07	08	09	10	11	12	13	14	15	16	17	18	19	20	21	22	23	24	25	26	27	28	29	30	31	32
IF1 #1F2#1F3 1DX										1TS 1EP																					
REPLY																															
01	02	03	04	05	06	07	08	09	10	11	12	13	14	15	16	17	18	19	20	21	22	23	24	25	26	27	28	29	30	31	32
1G1 1G2 1G3 1JD 1JL 1RF11RF2 1RT 1EC 1SB01SB11PR01PR1																															



Phase Timings						
Phase	Min	Ext	Max	Ped Black	Phase Type	Alternative Maximums
A	7				T	
B	7				T	
C	7				T	
D	7				T	
E	4				F	
F	6			5	P	
G	6			5	P	
H	6			3	P	
I	6			3	P	
J	3				D	

Issue	Site Number
2	06/000328/U

Phase Intergreens

		To Phase									
		A	B	C	D	E	F	G	H	I	J
From Phase	A			6		5				9	3
	B			6			6			15	3
	C	6	6			5			6		3
	D							5			3
	E	10		6			6			15	3
	F		11			11					5
	G				11						5
	H			8							3
	I	8	8			8					3
	J	2	2	2	2	2	2	2	2	2	



# TfL Street Management

## Timing Sheets

UTC Micro

Mode Priority	CLF PLAN1		CLF PLAN2		CLF PLAN3		CLF PLAN5		CLF PLAN8		Issue	Site Number
	Time Of Day	Operation Type	Time Of Day	Operation Type	Time Of Day	Operation Type	Time Of Day	Operation Type	Time Of Day	Operation Type		
UTC											2	06/000328/U
Hand Control												
Manual Select	05:30	9	10:30	9	15:00	9	01:00	7	22:00	7		
Hurry (1)					09:30	0						
Hurry (2)					09:30	1						
VA												
CLF												
Fix Time												
Bus Priority												
	Cycle Time		Cycle Time		Cycle Time		Cycle Time		Cycle Time			
	96		88		96		64		72			

Phase Delays				Phase Delays				Phase Delays				Phase Delays			
Stage From	Stage To	Phase Associated	Delay Period	Stage From	Stage To	Phase Associated	Delay Period	Stage From	Stage To	Phase Associated	Delay Period	Stage From	Stage To	Phase Associated	Delay Period
1	2	D	5												
3	1	C	5												

DET	Function	Phase	DET	Function	Phase	DET	Function	Phase	DET	Function	Phase
CIRD14	CAL	C	PB P11	CAL	I	SD1	SCM	A			
CSMVD16	CAL	C	PB P12	CAL	I	SD2	SCM	A			
EIRD6	CAN	E	PB P13	CAL	I	SD3	SCM	A			
PB P1	CAL	G	PB P14	CAL	H	SD4	SCM	A			
PB P3	CAL	G	PB P15	CAL	H	SD5	SCM	A			
PB P4	CAL	G	PB P16	CAL	H	SD6	SCM	A			
PB P5	CAL	F	iSB0	BUS		SD7	SCM	A			
PB P6	CAL	F	iSB1	BUS		SD0 (828)	SCM	A			
PB P7	CAL	F	SD0	SCM	A	SD1 (828)	SCM	A			

Issue	Historical Amendments
2	NEW PROM (TFL SPEC ISSUE 4) INSTALLED & UTC COMMISSIONED. SCOOT (MAGNETOMETERS) COMMISSIONED. 26-AUG-2015 CUBIC
1.1	CONTROLLER BASE REINSTATED - SNAGGING UPDATED. 09-NOV-2015 RICHESK
1	NEW JUNCTION INSTALLED & COMMISSIONED TO TFL SPEC ISSUE 3. 06-JAN-2015 DAHERH

Remarks	
Version No	4
Linking	NONE
Comments	TFL SPEC ISSUE 4. **2ND OTU AT 06/828.**
Det Strategy	SMVD - IRDs - PUSH BUTTONS / TACTILES - SCOOT (MAGNETOMETERS)
Amendment	NEW PROM (TFL SPEC ISSUE 4) INSTALLED & UTC COMMISSIONED. SCOOT (MAGNETOMETERS) COMMISSIONED. 26-AUG-2015 CUBIC

**Appendix B**  
**Bugsby's Way/Gallions Road**  
**LinSig Results**

Basic Results Summary  
**Basic Results Summary**

**Project and User Details**

<b>Project:</b>	<b>Charlton Riverside</b>
<b>Title:</b>	
<b>Location:</b>	
<b>File name:</b>	Site 1 - Bugsby's Way - Gallions Road.lsg3x
<b>Author:</b>	
<b>Company:</b>	
<b>Address:</b>	
<b>Notes:</b>	
<b>Linsig Version:</b>	3, 2, 28, 0

**Scenario 1: 'Baseline AM Peak'** (FG1: 'Baseline AM Peak', Plan 1: 'Network Control Plan 1')  
**Network Layout Diagram**

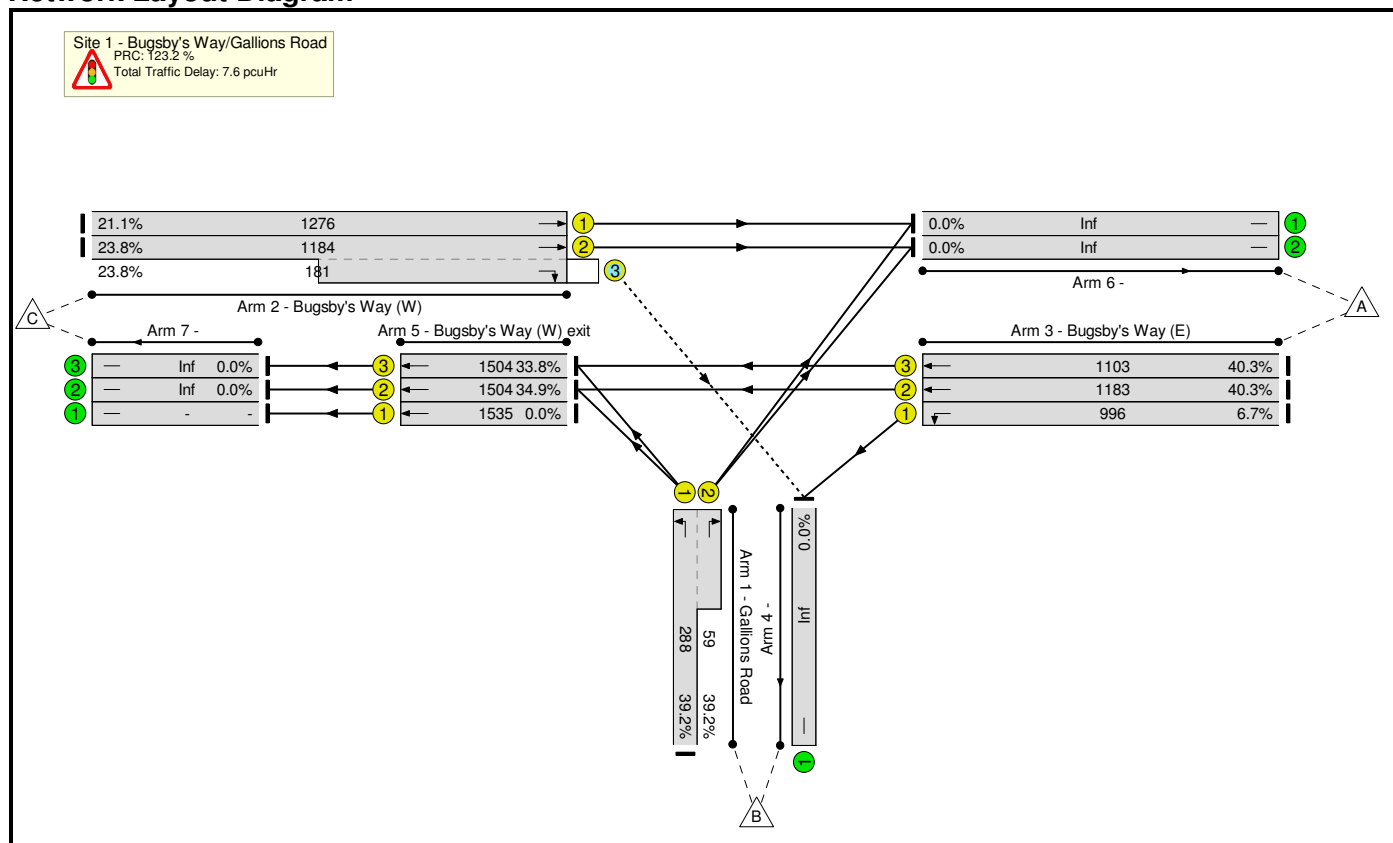

Basic Results Summary

**Network Results**

Item	Lane Description	Lane Type	Full Phase	Arrow Phase	Num Greens	Total Green (s)	Arrow Green (s)	Demand Flow (pcu)	Sat Flow (pcu/Hr)	Capacity (pcu)	Deg Sat (%)	Turners In Gaps (pcu)	Turners When Unopposed (pcu)	Turners In Intergreen (pcu)	Total Delay (pcuHr)	Av. Delay Per PCU (s/pcu)	Mean Max Queue (pcu)
<b>Network</b>	-	-	-		-	-	-	-	-	-	40.3%	38	4	1	7.6	-	-
<b>Site 1 - Bugsby's Way/Gallions Road</b>	-	-	-		-	-	-	-	-	-	40.3%	38	4	1	7.6	-	-
1/1+1/2	Gallions Road Left Right	U	C		1	15	-	136	1729:1691	288+59	39.2 : 39.2%	-	-	-	1.7	43.9	3.0
2/1	Bugsby's Way (W) Ahead	U	B		1	62	-	269	1945	1276	21.1%	-	-	-	0.6	8.4	3.0
2/2+2/3	Bugsby's Way (W) Right Ahead	U+O	B	E	1	62	0	325	1945:1757	1184+181	23.8 : 23.8%	38	4	1	0.8	8.9	3.1
3/1	Bugsby's Way (E) Left	U	A		1	54	-	67	1739	996	6.7%	-	-	-	0.2	11.1	0.8
3/2	Bugsby's Way (E) Ahead	U	A		1	54	-	477	2065	1183	40.3%	-	-	-	1.8	13.9	7.4
3/3	Bugsby's Way (E) Ahead	U	A		1	54	-	444	1925	1103	40.3%	-	-	-	1.7	14.1	6.9
5/1	Bugsby's Way (W) exit Ahead	U	D		1	74	-	0	1965	1535	0.0%	-	-	-	0.0	0.0	0.0
5/2	Bugsby's Way (W) exit Ahead	U	D		1	74	-	525	1925	1504	34.9%	-	-	-	0.4	2.5	5.8
5/3	Bugsby's Way (W) exit Ahead	U	D		1	74	-	509	1925	1504	33.8%	-	-	-	0.3	2.3	1.0
		C1			PRC for Signalled Lanes (%):		123.2	Total Delay for Signalled Lanes (pcuHr):		7.57		Cycle Time (s):		96			
				PRC Over All Lanes (%):		123.2		Total Delay Over All Lanes(pcuHr):		7.57							

Basic Results Summary

Scenario 2: 'Baseline PM Peak' (FG2: 'Baseline PM Peak', Plan 1: 'Network Control Plan 1')

Network Layout Diagram

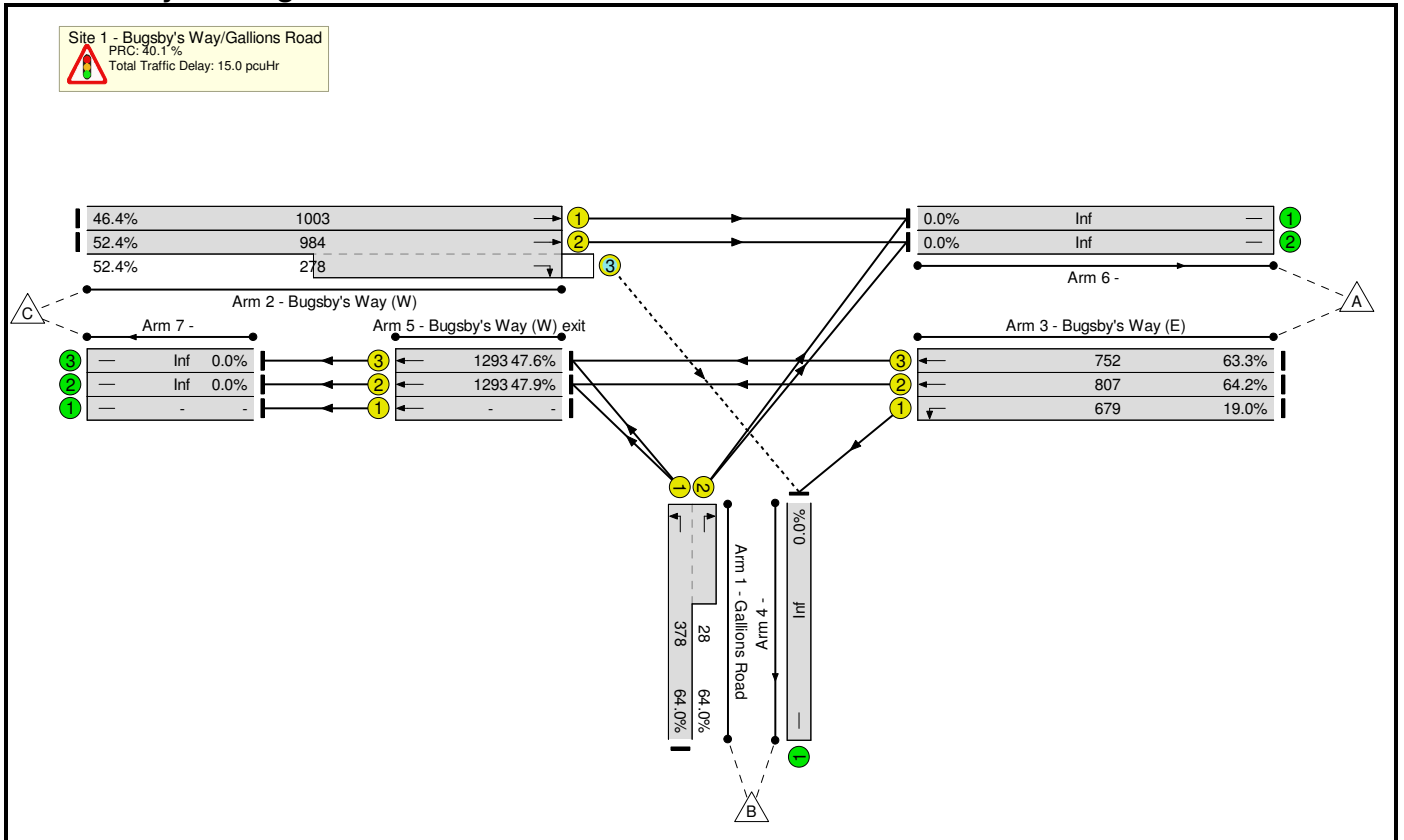

Basic Results Summary

**Network Results**

Item	Lane Description	Lane Type	Full Phase	Arrow Phase	Num Greens	Total Green (s)	Arrow Green (s)	Demand Flow (pcu)	Sat Flow (pcu/Hr)	Capacity (pcu)	Deg Sat (%)	Turners In Gaps (pcu)	Turners When Unopposed (pcu)	Turners In Intergreen (pcu)	Total Delay (pcuHr)	Av. Delay Per PCU (s/pcu)	Mean Max Queue (pcu)					
<b>Network</b>	-	-	-		-	-	-	-	-	-	64.2%	39	103	5	15.0	-	-					
<b>Site 1 - Bugsby's Way/Gallions Road</b>	-	-	-		-	-	-	-	-	-	64.2%	39	103	5	15.0	-	-					
1/1+1/2	Gallions Road Left Right	U	C		1	13	-	260	1729:1691	378+28	64.0 : 64.0%	-	-	-	2.5	34.7	4.8					
2/1	Bugsby's Way (W) Ahead	U	B		1	32	-	465	1945	1003	46.4%	-	-	-	1.7	13.2	5.6					
2/2+2/3	Bugsby's Way (W) Right Ahead	U+O	B	E	1	32	0	662	1945:1757	984+278	52.4 : 52.4%	39	103	5	2.9	15.7	6.6					
3/1	Bugsby's Way (E) Left	U	A		1	24	-	129	1739	679	19.0%	-	-	-	0.6	16.1	1.6					
3/2	Bugsby's Way (E) Ahead	U	A		1	24	-	518	2065	807	64.2%	-	-	-	3.2	22.1	8.4					
3/3	Bugsby's Way (E) Ahead	U	A		1	24	-	476	1925	752	63.3%	-	-	-	2.9	22.3	7.6					
5/1	Bugsby's Way (W) exit Ahead	U	D		1	42	-	0	1965	-	-	-	-	-	-	-	-					
5/2	Bugsby's Way (W) exit Ahead	U	D		1	42	-	620	1925	1293	47.9%	-	-	-	0.6	3.6	6.5					
5/3	Bugsby's Way (W) exit Ahead	U	D		1	42	-	616	1925	1293	47.6%	-	-	-	0.6	3.3	1.2					
		C1	PRC for Signalled Lanes (%):		40.1		PRC Over All Lanes (%):		40.1		Total Delay for Signalled Lanes (pcuHr):		14.98		Total Delay Over All Lanes(pcuHr):		14.98		Cycle Time (s):		64	

Basic Results Summary

**Scenario 3: 'Baseline Plus Proposed Development AM Peak'** (FG3: 'Baseline Plus Proposed Development AM Peak', Plan 1: 'Network Control Plan 1')

**Network Layout Diagram**

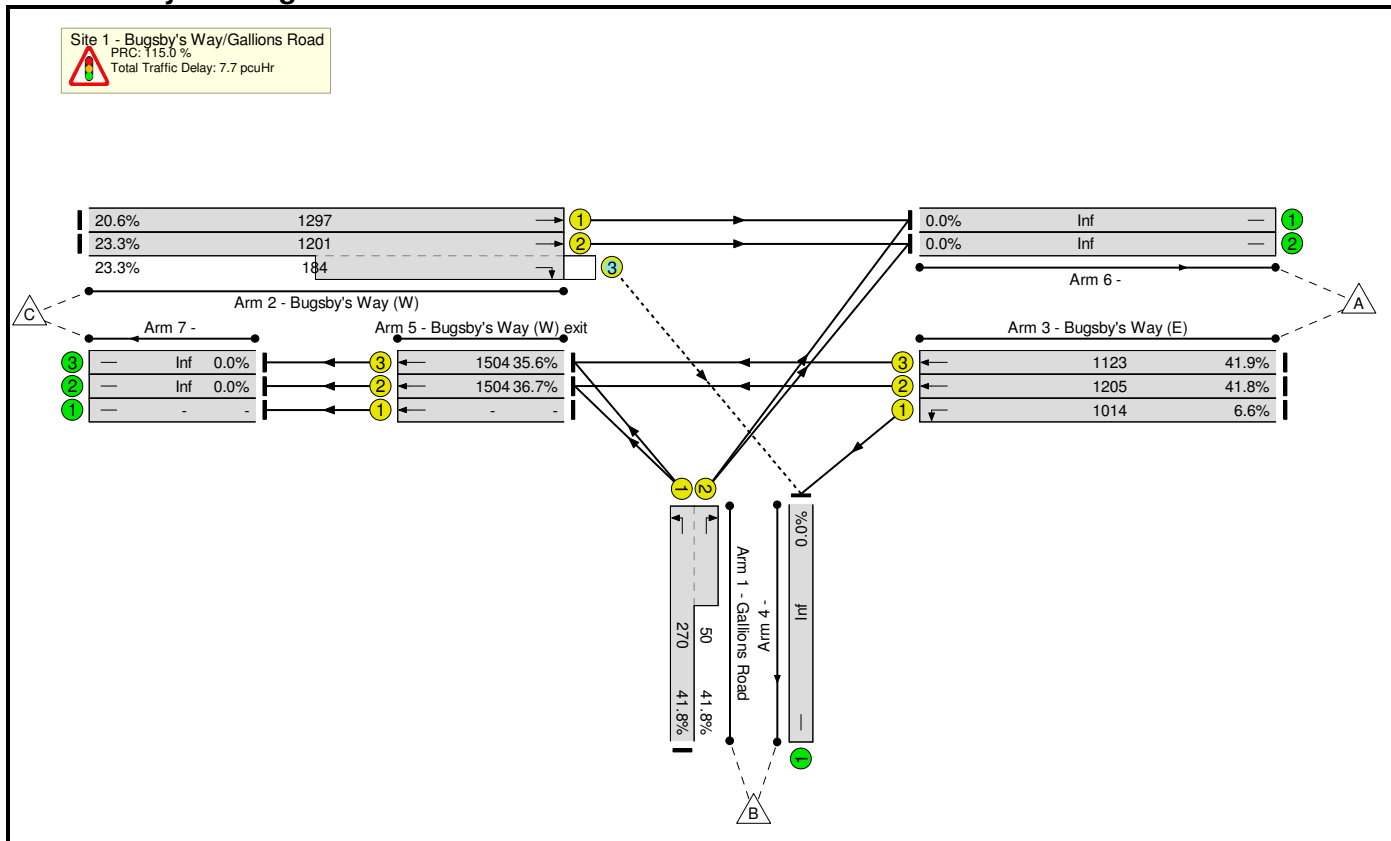

Basic Results Summary

**Network Results**

Item	Lane Description	Lane Type	Full Phase	Arrow Phase	Num Greens	Total Green (s)	Arrow Green (s)	Demand Flow (pcu)	Sat Flow (pcu/Hr)	Capacity (pcu)	Deg Sat (%)	Turners In Gaps (pcu)	Turners When Unopposed (pcu)	Turners In Intergreen (pcu)	Total Delay (pcuHr)	Av. Delay Per PCU (s/pcu)	Mean Max Queue (pcu)
<b>Network</b>	-	-	-		-	-	-	-	-	-	41.9%	38	4	1	7.7	-	-
<b>Site 1 - Bugsby's Way/Gallions Road</b>	-	-	-		-	-	-	-	-	-	41.9%	38	4	1	7.7	-	-
1/1+1/2	Gallions Road Left Right	U	C		1	14	-	134	1729:1691	270+50	41.8 : 41.8%	-	-	-	1.7	45.9	3.1
2/1	Bugsby's Way (W) Ahead	U	B		1	63	-	267	1945	1297	20.6%	-	-	-	0.6	7.9	2.9
2/2+2/3	Bugsby's Way (W) Right Ahead	U+O	B	E	1	63	0	323	1945:1757	1201+184	23.3 : 23.3%	38	4	1	0.8	8.5	3.0
3/1	Bugsby's Way (E) Left	U	A		1	55	-	67	1739	1014	6.6%	-	-	-	0.2	10.6	0.8
3/2	Bugsby's Way (E) Ahead	U	A		1	55	-	504	2065	1205	41.8%	-	-	-	1.9	13.6	7.6
3/3	Bugsby's Way (E) Ahead	U	A		1	55	-	470	1925	1123	41.9%	-	-	-	1.8	13.8	7.1
5/1	Bugsby's Way (W) exit Ahead	U	D		1	74	-	0	1965	-	-	-	-	-	-	-	-
5/2	Bugsby's Way (W) exit Ahead	U	D		1	74	-	552	1925	1504	36.7%	-	-	-	0.4	2.6	6.3
5/3	Bugsby's Way (W) exit Ahead	U	D		1	74	-	535	1925	1504	35.6%	-	-	-	0.4	2.4	1.0
		C1			PRC for Signalled Lanes (%):		115.0	Total Delay for Signalled Lanes (pcuHr):		7.71		Cycle Time (s):		96			
				PRC Over All Lanes (%):		115.0		Total Delay Over All Lanes(pcuHr):		7.71							

Basic Results Summary

**Scenario 4: 'Baseline Plus Proposed Development PM Peak'** (FG4: 'Baseline Plus Proposed Development PM Peak', Plan 1: 'Network Control Plan 1')

**Network Layout Diagram**

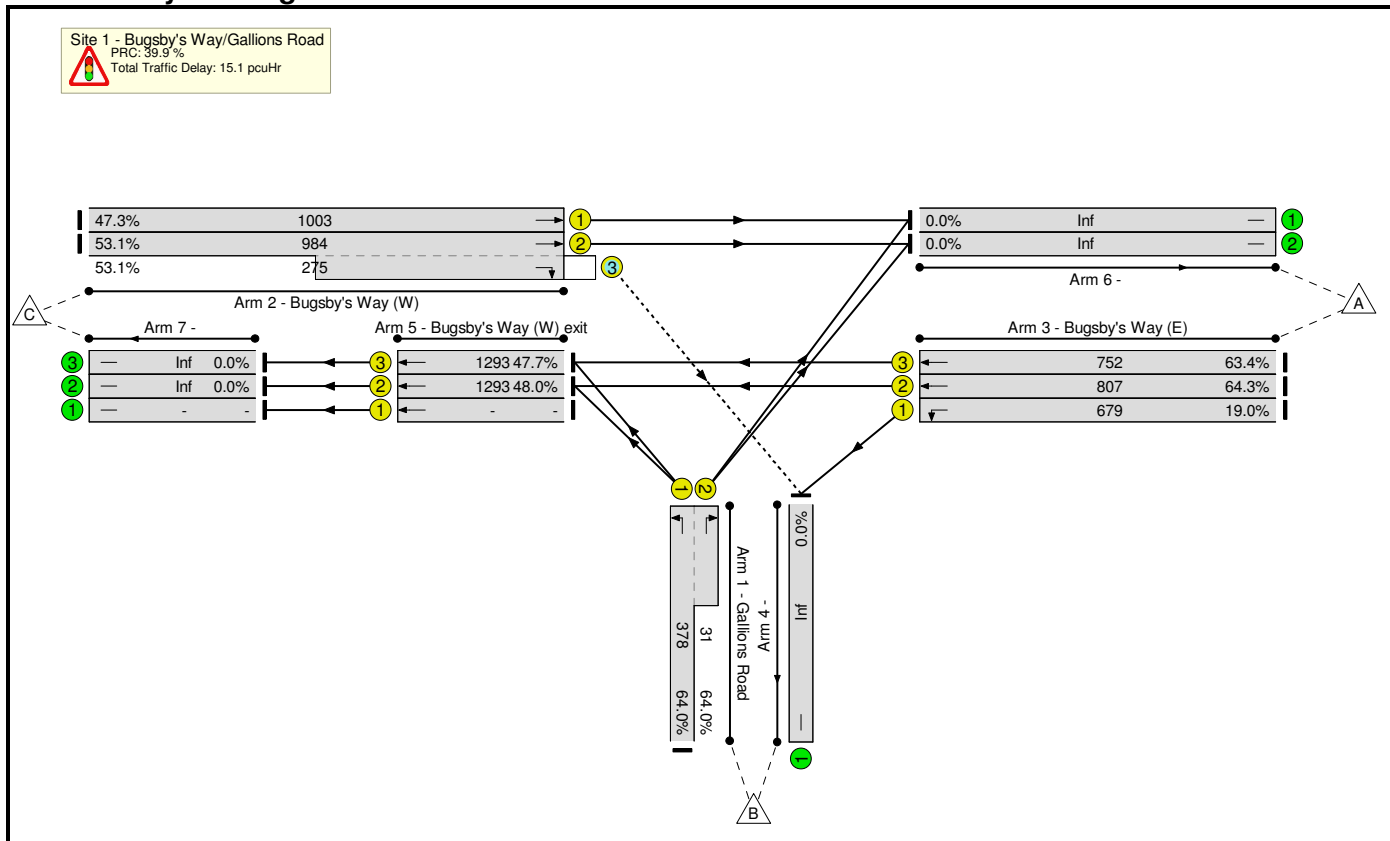

Basic Results Summary

**Network Results**

Item	Lane Description	Lane Type	Full Phase	Arrow Phase	Num Greens	Total Green (s)	Arrow Green (s)	Demand Flow (pcu)	Sat Flow (pcu/Hr)	Capacity (pcu)	Deg Sat (%)	Turners In Gaps (pcu)	Turners When Unopposed (pcu)	Turners In Intergreen (pcu)	Total Delay (pcuHr)	Av. Delay Per PCU (s/pcu)	Mean Max Queue (pcu)					
<b>Network</b>	-	-	-		-	-	-	-	-	-	64.3%	37	104	5	15.1	-	-					
<b>Site 1 - Bugsby's Way/Gallions Road</b>	-	-	-		-	-	-	-	-	-	64.3%	37	104	5	15.1	-	-					
1/1+1/2	Gallions Road Left Right	U	C		1	13	-	262	1729:1691	378+31	64.0 : 64.0%	-	-	-	2.5	34.6	4.8					
2/1	Bugsby's Way (W) Ahead	U	B		1	32	-	474	1945	1003	47.3%	-	-	-	1.8	13.3	5.7					
2/2+2/3	Bugsby's Way (W) Right Ahead	U+O	B	E	1	32	0	669	1945:1757	984+275	53.1 : 53.1%	37	104	5	2.9	15.8	6.7					
3/1	Bugsby's Way (E) Left	U	A		1	24	-	129	1739	679	19.0%	-	-	-	0.6	16.1	1.6					
3/2	Bugsby's Way (E) Ahead	U	A		1	24	-	519	2065	807	64.3%	-	-	-	3.2	22.1	8.4					
3/3	Bugsby's Way (E) Ahead	U	A		1	24	-	477	1925	752	63.4%	-	-	-	3.0	22.3	7.6					
5/1	Bugsby's Way (W) exit Ahead	U	D		1	42	-	0	1965	-	-	-	-	-	-	-	-					
5/2	Bugsby's Way (W) exit Ahead	U	D		1	42	-	621	1925	1293	48.0%	-	-	-	0.6	3.6	6.5					
5/3	Bugsby's Way (W) exit Ahead	U	D		1	42	-	617	1925	1293	47.7%	-	-	-	0.6	3.3	1.2					
		C1	PRC for Signalled Lanes (%):		39.9		PRC Over All Lanes (%):		39.9		Total Delay for Signalled Lanes (pcuHr):		15.11		Total Delay Over All Lanes(pcuHr):		15.11		Cycle Time (s):		64	

Basic Results Summary

**Scenario 5: 'Baseline Plus Other Cumulative Developments AM Peak'** (FG5: 'Baseline Plus Other Cumulative Developments AM Peak', Plan 1: 'Network Control Plan 1')

**Network Layout Diagram**

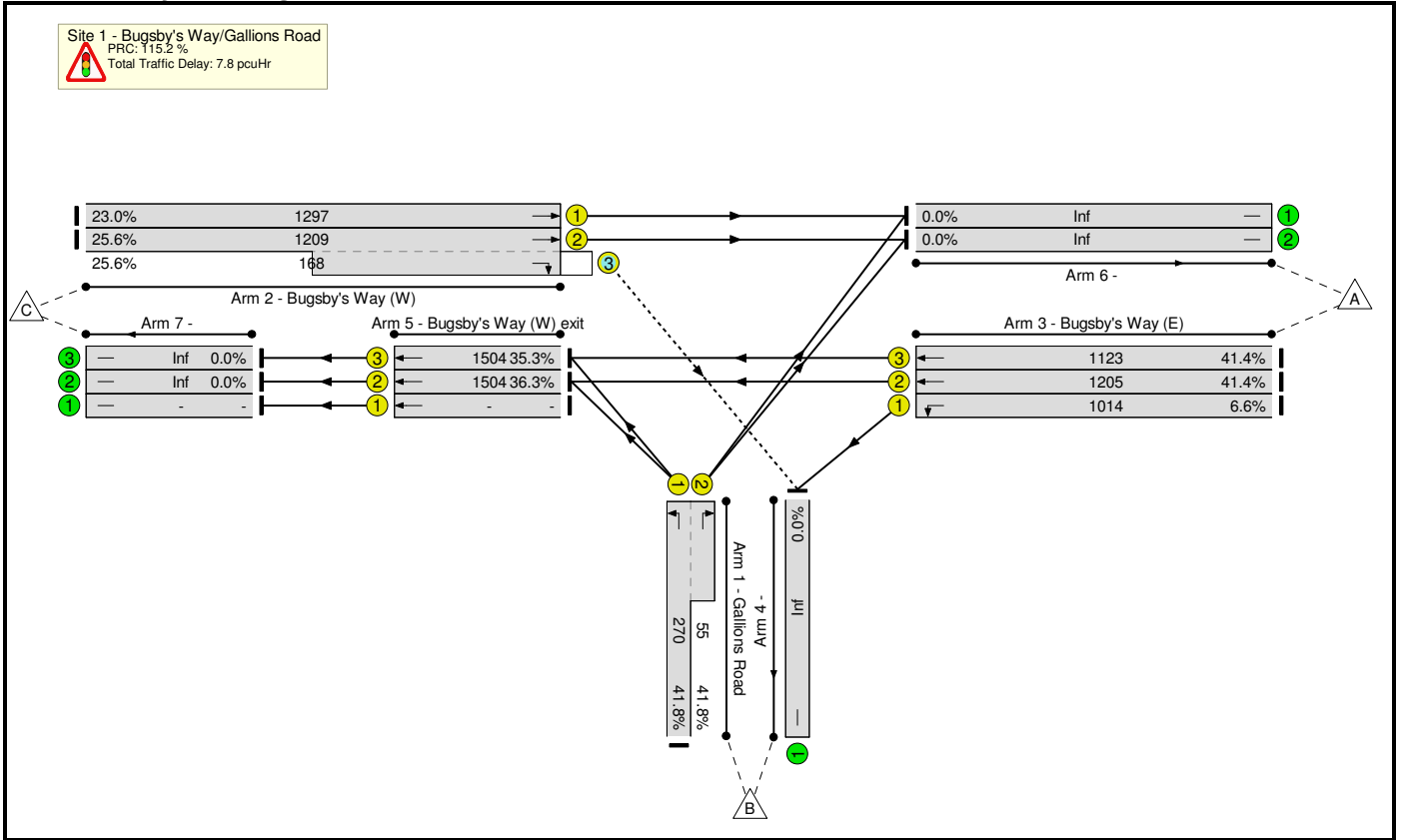

Basic Results Summary

**Network Results**

Item	Lane Description	Lane Type	Full Phase	Arrow Phase	Num Greens	Total Green (s)	Arrow Green (s)	Demand Flow (pcu)	Sat Flow (pcu/Hr)	Capacity (pcu)	Deg Sat (%)	Turners In Gaps (pcu)	Turners When Unopposed (pcu)	Turners In Intergreen (pcu)	Total Delay (pcuHr)	Av. Delay Per PCU (s/pcu)	Mean Max Queue (pcu)
<b>Network</b>	-	-	-		-	-	-	-	-	-	41.8%	38	4	1	7.8	-	-
<b>Site 1 - Bugsby's Way/Gallions Road</b>	-	-	-		-	-	-	-	-	-	41.8%	38	4	1	7.8	-	-
1/1+1/2	Gallions Road Left Right	U	C		1	14	-	136	1729:1691	270+55	41.8 : 41.8%	-	-	-	1.7	45.7	3.1
2/1	Bugsby's Way (W) Ahead	U	B		1	63	-	298	1945	1297	23.0%	-	-	-	0.7	8.1	3.2
2/2+2/3	Bugsby's Way (W) Right Ahead	U+O	B	E	1	63	0	353	1945:1757	1209+168	25.6 : 25.6%	38	4	1	0.8	8.6	3.4
3/1	Bugsby's Way (E) Left	U	A		1	55	-	67	1739	1014	6.6%	-	-	-	0.2	10.6	0.8
3/2	Bugsby's Way (E) Ahead	U	A		1	55	-	499	2065	1205	41.4%	-	-	-	1.9	13.5	7.6
3/3	Bugsby's Way (E) Ahead	U	A		1	55	-	465	1925	1123	41.4%	-	-	-	1.8	13.7	7.1
5/1	Bugsby's Way (W) exit Ahead	U	D		1	74	-	0	1965	-	-	-	-	-	-	-	-
5/2	Bugsby's Way (W) exit Ahead	U	D		1	74	-	546	1925	1504	36.3%	-	-	-	0.4	2.5	6.2
5/3	Bugsby's Way (W) exit Ahead	U	D		1	74	-	531	1925	1504	35.3%	-	-	-	0.3	2.4	1.0
		C1			PRC for Signalled Lanes (%):		115.2	Total Delay for Signalled Lanes (pcuHr):		7.82		Cycle Time (s):		96			
				PRC Over All Lanes (%):		115.2		Total Delay Over All Lanes(pcuHr):		7.82							

Basic Results Summary

**Scenario 6: 'Baseline Plus Other Cumulative Developments PM Peak'** (FG6: 'Baseline Plus Other Cumulative Developments PM Peak', Plan 1: 'Network Control Plan 1')

**Network Layout Diagram**

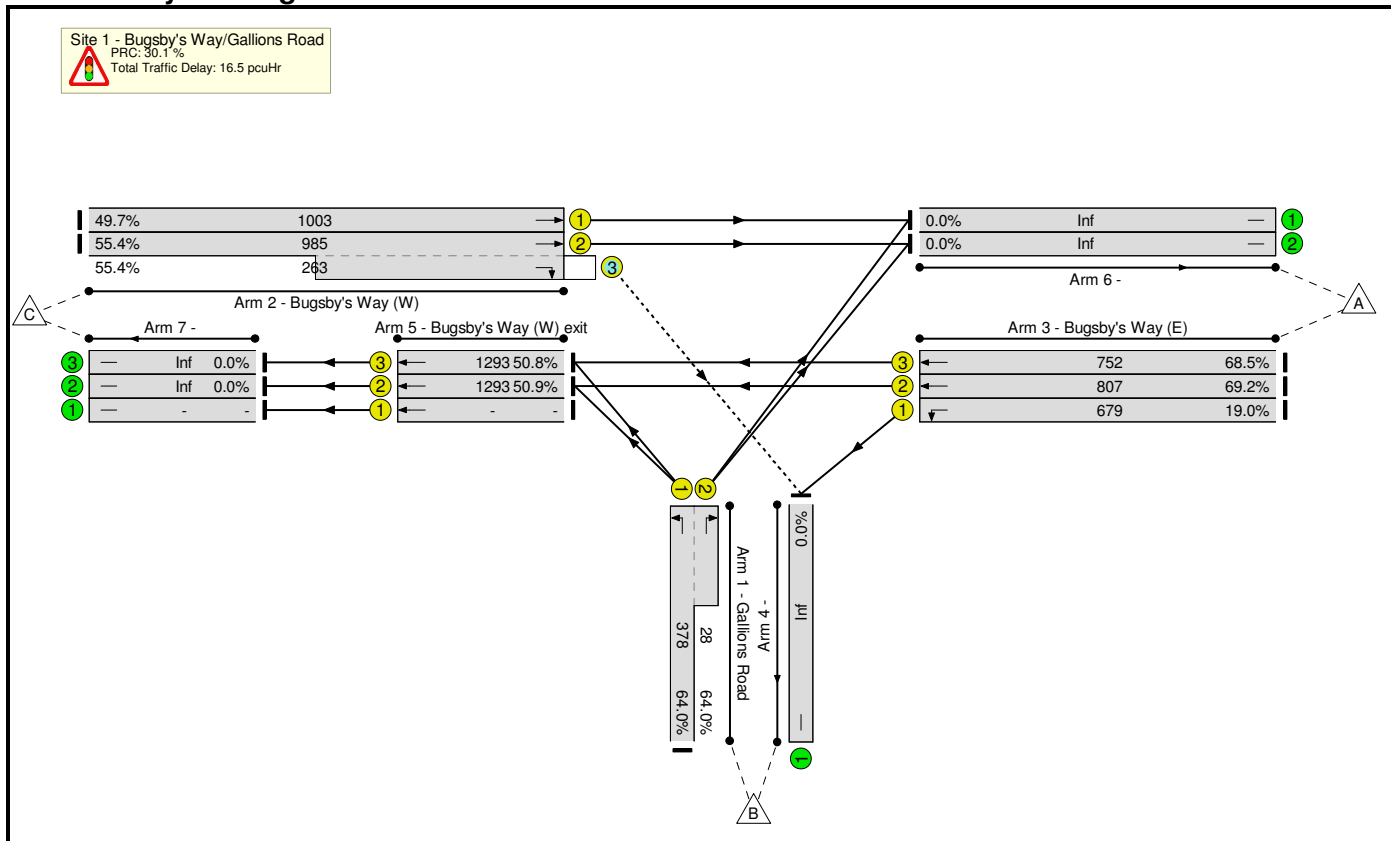

Basic Results Summary

**Network Results**

Item	Lane Description	Lane Type	Full Phase	Arrow Phase	Num Greens	Total Green (s)	Arrow Green (s)	Demand Flow (pcu)	Sat Flow (pcu/Hr)	Capacity (pcu)	Deg Sat (%)	Turners In Gaps (pcu)	Turners When Unopposed (pcu)	Turners In Intergreen (pcu)	Total Delay (pcuHr)	Av. Delay Per PCU (s/pcu)	Mean Max Queue (pcu)					
<b>Network</b>	-	-	-		-	-	-	-	-	-	69.2%	20	121	5	16.5	-	-					
<b>Site 1 - Bugsby's Way/Gallions Road</b>	-	-	-		-	-	-	-	-	-	69.2%	20	121	5	16.5	-	-					
1/1+1/2	Gallions Road Left Right	U	C		1	13	-	260	1729:1691	378+28	64.0 : 64.0%	-	-	-	2.5	34.7	4.8					
2/1	Bugsby's Way (W) Ahead	U	B		1	32	-	498	1945	1003	49.7%	-	-	-	1.9	13.7	6.2					
2/2+2/3	Bugsby's Way (W) Right Ahead	U+O	B	E	1	32	0	692	1945:1757	985+263	55.4 : 55.4%	20	121	5	3.1	16.2	7.1					
3/1	Bugsby's Way (E) Left	U	A		1	24	-	129	1739	679	19.0%	-	-	-	0.6	16.1	1.6					
3/2	Bugsby's Way (E) Ahead	U	A		1	24	-	558	2065	807	69.2%	-	-	-	3.6	23.5	9.3					
3/3	Bugsby's Way (E) Ahead	U	A		1	24	-	515	1925	752	68.5%	-	-	-	3.4	23.8	8.7					
5/1	Bugsby's Way (W) exit Ahead	U	D		1	42	-	0	1965	-	-	-	-	-	-	-	-					
5/2	Bugsby's Way (W) exit Ahead	U	D		1	42	-	658	1925	1293	50.9%	-	-	-	0.7	3.8	7.5					
5/3	Bugsby's Way (W) exit Ahead	U	D		1	42	-	657	1925	1293	50.8%	-	-	-	0.6	3.5	1.3					
		C1	PRC for Signalled Lanes (%):		30.1		PRC Over All Lanes (%):		30.1		Total Delay for Signalled Lanes (pcuHr):		16.46		Total Delay Over All Lanes(pcuHr):		16.46		Cycle Time (s):		64	

Basic Results Summary

**Scenario 7: 'Cumulative Development Scenario AM Peak'** (FG7: 'Cumulative Development Scenario AM Peak', Plan 1: 'Network Control Plan 1')

**Network Layout Diagram**

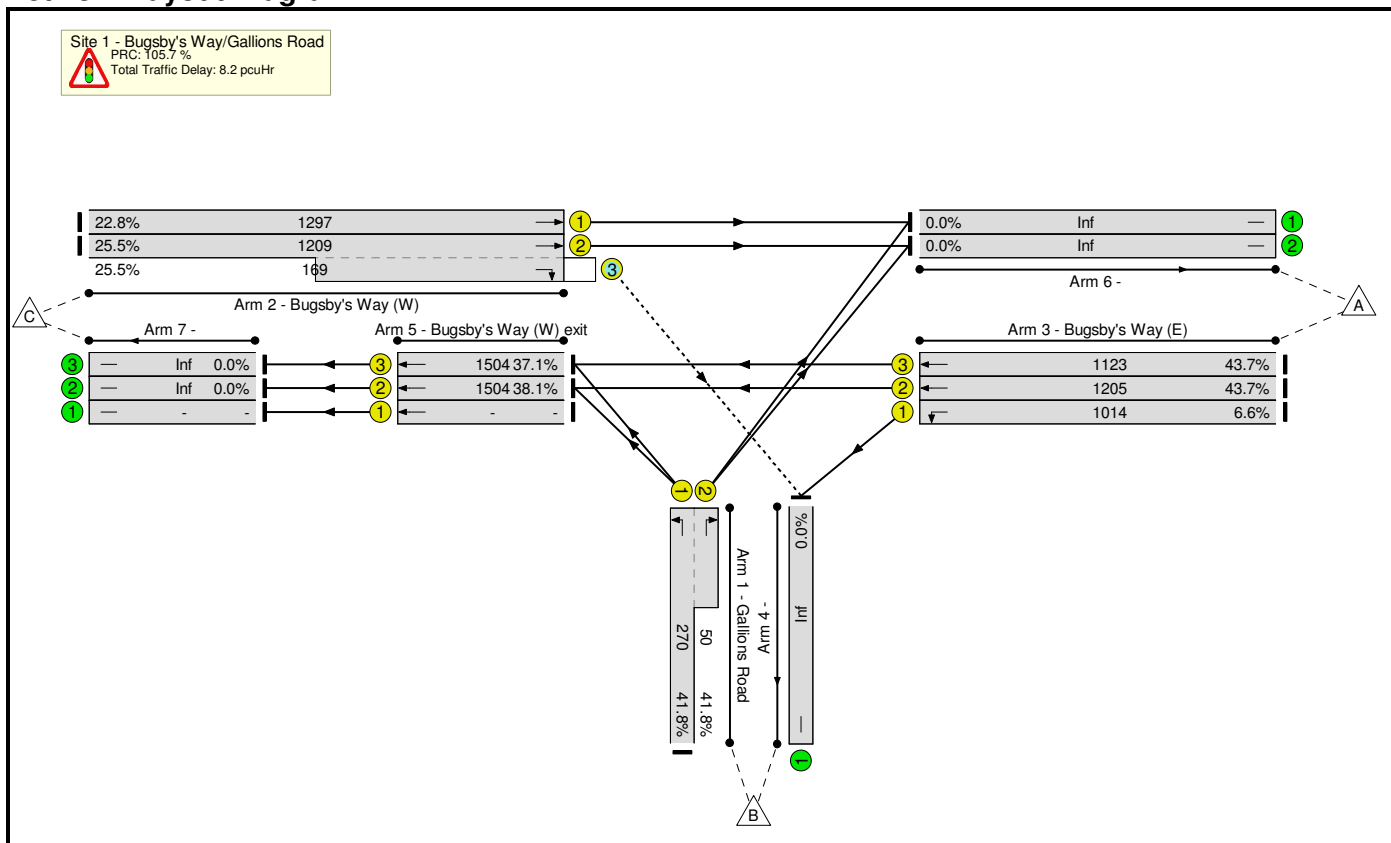

Basic Results Summary

**Network Results**

Item	Lane Description	Lane Type	Full Phase	Arrow Phase	Num Greens	Total Green (s)	Arrow Green (s)	Demand Flow (pcu)	Sat Flow (pcu/Hr)	Capacity (pcu)	Deg Sat (%)	Turners In Gaps (pcu)	Turners When Unopposed (pcu)	Turners In Intergreen (pcu)	Total Delay (pcuHr)	Av. Delay Per PCU (s/pcu)	Mean Max Queue (pcu)
<b>Network</b>	-	-	-		-	-	-	-	-	-	<b>43.7%</b>	<b>38</b>	<b>4</b>	<b>1</b>	<b>8.2</b>	-	-
<b>Site 1 - Bugsby's Way/Gallions Road</b>	-	-	-		-	-	-	-	-	-	<b>43.7%</b>	<b>38</b>	<b>4</b>	<b>1</b>	<b>8.2</b>	-	-
1/1+1/2	Gallions Road Left Right	U	C		1	14	-	134	1729:1691	270+50	41.8 : 41.8%	-	-	-	1.7	45.9	3.1
2/1	Bugsby's Way (W) Ahead	U	B		1	63	-	296	1945	1297	22.8%	-	-	-	0.7	8.1	3.2
2/2+2/3	Bugsby's Way (W) Right Ahead	U+O	B	E	1	63	0	351	1945:1757	1209+169	25.5 : 25.5%	38	4	1	0.9	8.7	3.4
3/1	Bugsby's Way (E) Left	U	A		1	55	-	67	1739	1014	6.6%	-	-	-	0.2	10.6	0.8
3/2	Bugsby's Way (E) Ahead	U	A		1	55	-	527	2065	1205	43.7%	-	-	-	2.0	13.8	8.1
3/3	Bugsby's Way (E) Ahead	U	A		1	55	-	491	1925	1123	43.7%	-	-	-	1.9	14.0	7.6
5/1	Bugsby's Way (W) exit Ahead	U	D		1	74	-	0	1965	-	-	-	-	-	-	-	-
5/2	Bugsby's Way (W) exit Ahead	U	D		1	74	-	573	1925	1504	38.1%	-	-	-	0.4	2.6	6.8
5/3	Bugsby's Way (W) exit Ahead	U	D		1	74	-	558	1925	1504	37.1%	-	-	-	0.4	2.4	1.1
		C1			PRC for Signalled Lanes (%):		105.7	Total Delay for Signalled Lanes (pcuHr):		8.15		Cycle Time (s):		96			
				PRC Over All Lanes (%):		105.7		Total Delay Over All Lanes(pcuHr):		8.15							

Basic Results Summary

**Scenario 8: 'Cumulative Development Scenario PM Peak'** (FG8: 'Cumulative Development Scenario PM Peak', Plan 1: 'Network Control Plan 1')

**Network Layout Diagram**

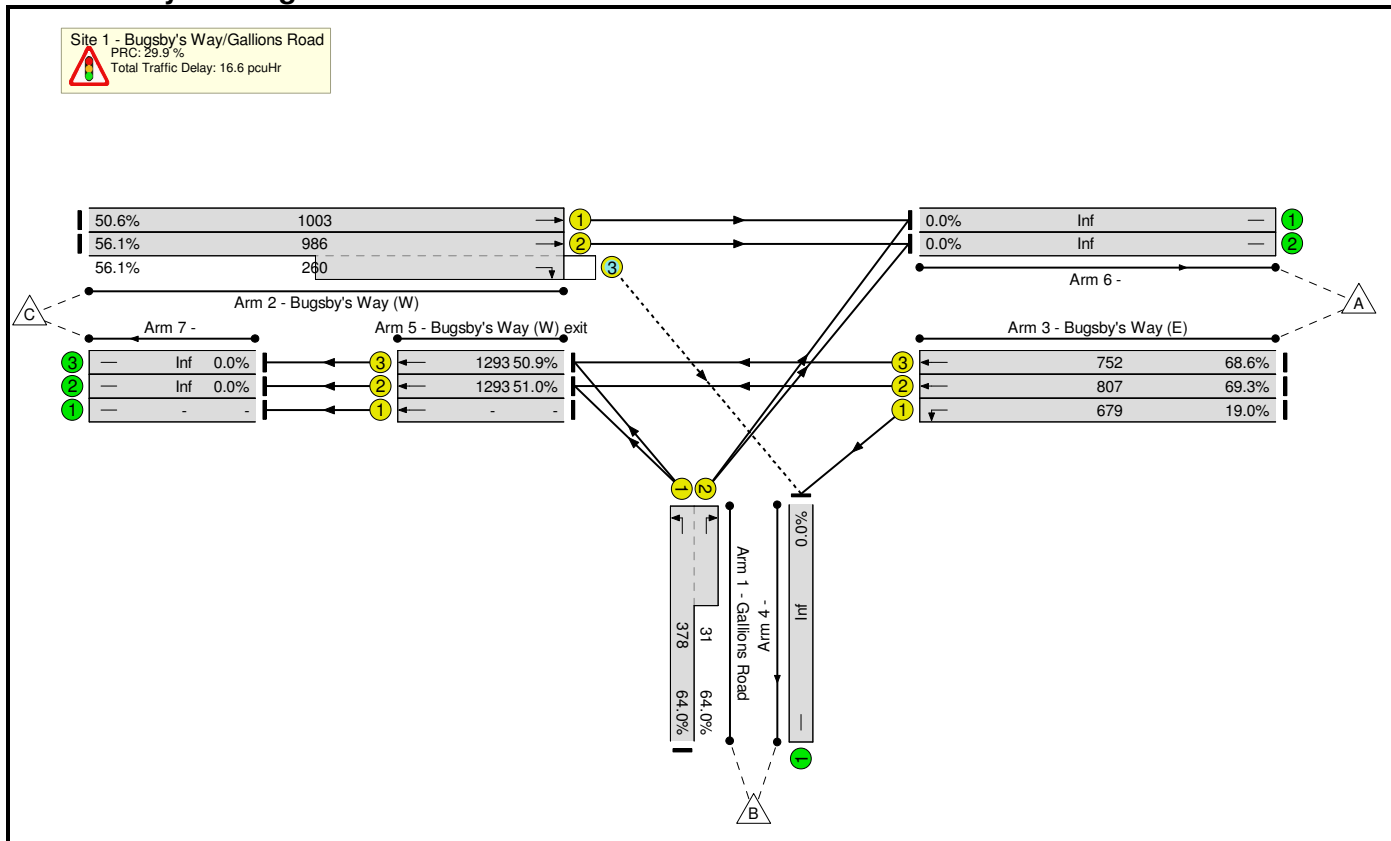

Basic Results Summary

**Network Results**

Item	Lane Description	Lane Type	Full Phase	Arrow Phase	Num Greens	Total Green (s)	Arrow Green (s)	Demand Flow (pcu)	Sat Flow (pcu/Hr)	Capacity (pcu)	Deg Sat (%)	Turners In Gaps (pcu)	Turners When Unopposed (pcu)	Turners In Intergreen (pcu)	Total Delay (pcuHr)	Av. Delay Per PCU (s/pcu)	Mean Max Queue (pcu)					
<b>Network</b>	-	-	-		-	-	-	-	-	-	69.3%	20	122	5	16.6	-	-					
<b>Site 1 - Bugsby's Way/Gallions Road</b>	-	-	-		-	-	-	-	-	-	69.3%	20	122	5	16.6	-	-					
1/1+1/2	Gallions Road Left Right	U	C		1	13	-	262	1729:1691	378+31	64.0 : 64.0%	-	-	-	2.5	34.6	4.8					
2/1	Bugsby's Way (W) Ahead	U	B		1	32	-	507	1945	1003	50.6%	-	-	-	1.9	13.8	6.3					
2/2+2/3	Bugsby's Way (W) Right Ahead	U+O	B	E	1	32	0	699	1945:1757	986+260	56.1 : 56.1%	20	122	5	3.2	16.3	7.2					
3/1	Bugsby's Way (E) Left	U	A		1	24	-	129	1739	679	19.0%	-	-	-	0.6	16.1	1.6					
3/2	Bugsby's Way (E) Ahead	U	A		1	24	-	559	2065	807	69.3%	-	-	-	3.6	23.5	9.3					
3/3	Bugsby's Way (E) Ahead	U	A		1	24	-	516	1925	752	68.6%	-	-	-	3.4	23.8	8.7					
5/1	Bugsby's Way (W) exit Ahead	U	D		1	42	-	0	1965	-	-	-	-	-	-	-	-					
5/2	Bugsby's Way (W) exit Ahead	U	D		1	42	-	659	1925	1293	51.0%	-	-	-	0.7	3.8	7.5					
5/3	Bugsby's Way (W) exit Ahead	U	D		1	42	-	658	1925	1293	50.9%	-	-	-	0.6	3.5	1.3					
		C1	PRC for Signalled Lanes (%):		29.9		PRC Over All Lanes (%):		29.9		Total Delay for Signalled Lanes (pcuHr):		16.60		Total Delay Over All Lanes(pcuHr):		16.60		Cycle Time (s):		64	

**Appendix C**  
**Gallions Road/Woolwich Road**  
**PICADY Results**

<b>Junctions 9</b>
<b>PICADY 9 - Priority Intersection Module</b>
Version: 9.0.0.4211 [] © Copyright TRL Limited, 2017
For sales and distribution information, program advice and maintenance, contact TRL: Tel: +44 (0)1344 770758 email: software@trl.co.uk Web: http://www.trlsoftware.co.uk
<b>The users of this computer program for the solution of an engineering problem are in no way relieved of their responsibility for the correctness of the solution</b>

**Filename:** Site 2 - Woolwich Road - Gallions Road.j9

**Path:** T:\30000\_Projects\30821 Charlton Riverside, Greenwich\Junction modelling\Site 2

**Report generation date:** 04/12/2017 10:01:21

- 
- »2016 Baseline, AM
  - »2016 Baseline, PM
  - »Baseline Plus Proposed Development, AM
  - »Baseline Plus Proposed Development, PM
  - »Baseline Plus Other Cumulative Developments, AM
  - »Baseline Plus Other Cumulative Developments, PM
  - »Cumulative Development Scenario, AM
  - »Cumulative Development Scenario, PM

## Summary of junction performance

	AM				PM			
	Queue (Veh)	Delay (s)	RFC	LOS	Queue (Veh)	Delay (s)	RFC	LOS
<b>2016 Baseline</b>								
Stream B-C	0.1	7.49	0.11	A	0.5	8.88	0.32	A
Stream B-A	0.0	0.00	0.00	A	0.0	0.00	0.00	A
Stream C-AB	0.0	0.00	0.00	A	0.0	0.00	0.00	A
Stream C-A								
Stream A-B								
Stream A-C								
<b>Baseline Plus Proposed Development</b>								
Stream B-C	0.1	7.48	0.11	A	0.5	8.90	0.32	A
Stream B-A	0.0	0.00	0.00	A	0.0	0.00	0.00	A
Stream C-AB	0.0	0.00	0.00	A	0.0	0.00	0.00	A
Stream C-A								
Stream A-B								
Stream A-C								
<b>Baseline Plus Other Cumulative Developments</b>								
Stream B-C	0.1	7.84	0.11	A	0.5	9.20	0.33	A
Stream B-A	0.0	0.00	0.00	A	0.0	0.00	0.00	A
Stream C-AB	0.0	0.00	0.00	A	0.0	0.00	0.00	A
Stream C-A								
Stream A-B								
Stream A-C								
<b>Cumulative Development Scenario</b>								
Stream B-C	0.1	7.85	0.11	A	0.5	9.22	0.33	A
Stream B-A	0.0	0.00	0.00	A	0.0	0.00	0.00	A
Stream C-AB	0.0	0.00	0.00	A	0.0	0.00	0.00	A
Stream C-A								
Stream A-B								
Stream A-C								

Values shown are the highest values encountered over all time segments. Delay is the maximum value of average delay per arriving vehicle.

## File summary

### File Description

Title	(untitled)
Location	
Site number	
Date	30/08/2016
Version	
Status	(new file)
Identifier	
Client	
Jobnumber	
Enumerator	TPP111"techuser
Description	

### Units

Distance units	Speed units	Traffic units input	Traffic units results	Flow units	Average delay units	Total delay units	Rate of delay units
m	kph	Veh	Veh	perHour	s	-Min	perMin

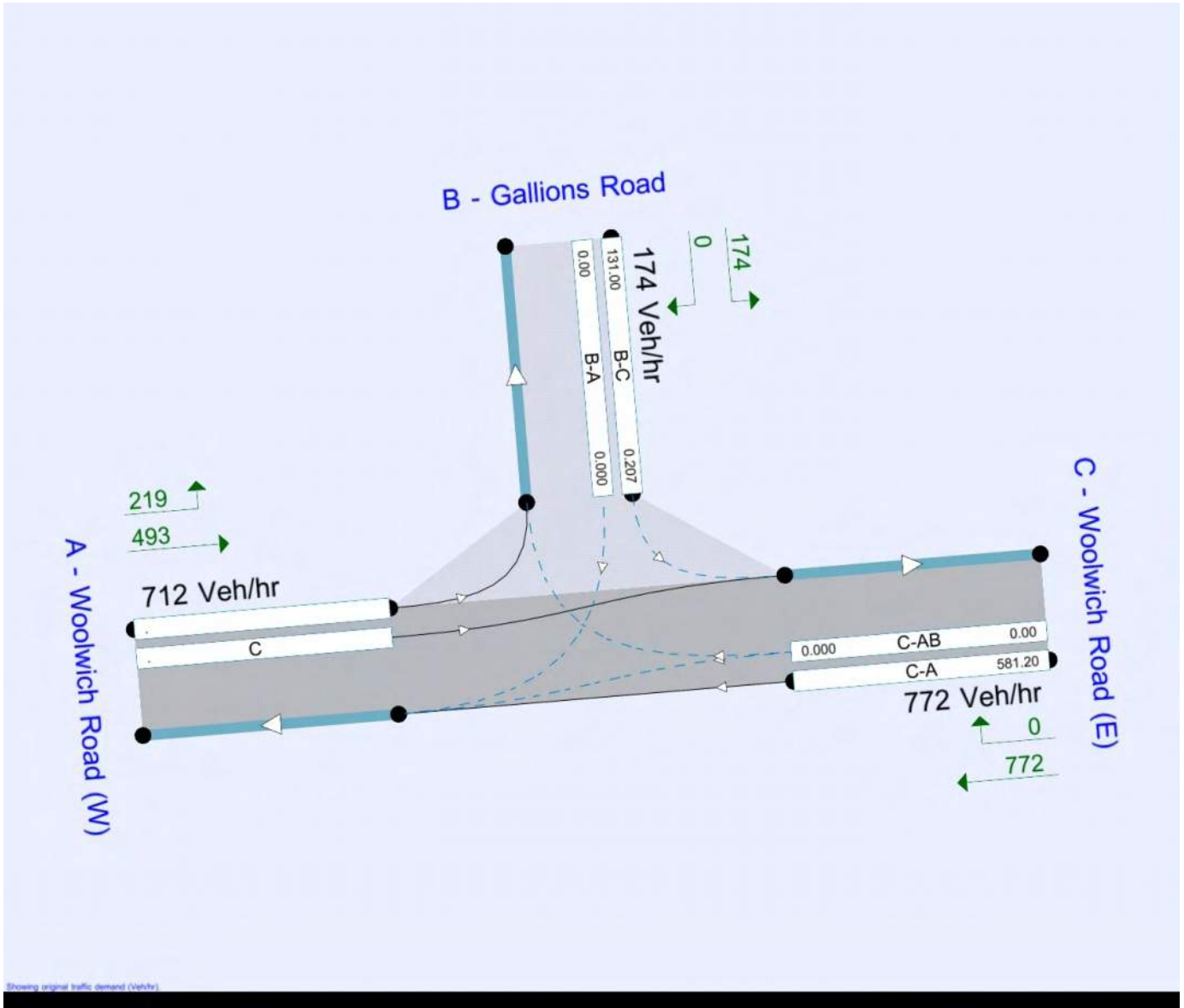

The junction diagram reflects the last run of Junctions.

### Analysis Options

Calculate Queue Percentiles	Calculate residual capacity	RFC Threshold	Average Delay threshold (s)	Queue threshold (PCU)
		0.85	36.00	20.00

## Demand Set Summary

Scenario name	Time Period name	Traffic profile type	Model start time (HH:mm)	Model finish time (HH:mm)	Time segment length (min)
2016 Baseline	AM	ONE HOUR	08:00	09:30	15
2016 Baseline	PM	ONE HOUR	17:00	18:30	15
Baseline Plus Proposed Development	AM	ONE HOUR	08:00	09:30	15
Baseline Plus Proposed Development	PM	ONE HOUR	17:00	18:30	15
Baseline Plus Other Cumulative Developments	AM	ONE HOUR	08:00	09:30	15
Baseline Plus Other Cumulative Developments	PM	ONE HOUR	17:00	18:30	15
Cumulative Development Scenario	AM	ONE HOUR	08:00	09:30	15
Cumulative Development Scenario	PM	ONE HOUR	17:00	18:30	15

# 2016 Baseline, AM

## Data Errors and Warnings

No errors or warnings

## Analysis Set Details

ID	Network flow scaling factor (%)
A1	100.000

# Junction Network

## Junctions

Junction	Name	Junction Type	Major road direction	Junction Delay (s)	Junction LOS
1 - untitled	untitled	T-Junction	Two-way	0.28	A

## Junction Network Options

Driving side	Lighting
Left	Normal/unknown

# Arms

## Arms

Arm	Name	Description	Arm type
A	Woolwich Road (W)		Major
B	Gallions Road		Minor
C	Woolwich Road (E)		Major

## Major Arm Geometry

Arm	Width of carriageway (m)	Has kerbed central reserve	Width of kerbed central reserve (m)	Has right turn bay	Visibility for right turn (m)	Blocks?	Blocking queue (PCU)
C - Woolwich Road (E)	9.45	✓	2.20		0.0	✓	0.00

Geometries for Arm C are measured opposite Arm B. Geometries for Arm A (if relevant) are measured opposite Arm D.

## Minor Arm Geometry

Arm	Minor arm type	Width at give-way (m)	Width at 5m (m)	Width at 10m (m)	Width at 15m (m)	Width at 20m (m)	Estimate flare length	Flare length (PCU)	Visibility to left (m)	Visibility to right (m)
B - Gallions Road	One lane plus flare	10.00	5.20	4.20	4.20	4.20	✓	1.00	0	38

## Slope / Intercept / Capacity

### Priority Intersection Slopes and Intercepts

Junction	Stream	Intercept (Veh/hr)	Slope for A-B	Slope for A-C	Slope for C-A	Slope for C-B
1	B-A	499.894	0.074	0.186	0.117	0.266
1	B-C	746.739	0.097	0.246	-	-
1	C-B	573.963	0.189	0.189	-	-

The slopes and intercepts shown above do NOT include any corrections or adjustments.

Streams may be combined, in which case capacity will be adjusted.

Values are shown for the first time segment only; they may differ for subsequent time segments.

## Traffic Demand

### Demand Set Details

ID	Scenario name	Time Period name	Traffic profile type	Model start time (HH:mm)	Model finish time (HH:mm)	Time segment length (min)
D1	2016 Baseline	AM	ONE HOUR	08:00	09:30	15

Vehicle mix varies over turn	Vehicle mix varies over entry	Vehicle mix source	PCU Factor for a HV (PCU)
✓	✓	HV Percentages	2.00

### Demand overview (Traffic)

Arm	Linked arm	Use O-D data	Average Demand (Veh/hr)	Scaling Factor (%)
A - Woolwich Road (W)		✓	757.00	100.000
B - Gallions Road		✓	54.00	100.000
C - Woolwich Road (E)		✓	550.00	100.000

## Origin-Destination Data

### Demand (Veh/hr)

		To		
		A - Woolwich Road (W)	B - Gallions Road	C - Woolwich Road (E)
From	A - Woolwich Road (W)	0.000	148.000	609.000
	B - Gallions Road	0.000	0.000	54.000
	C - Woolwich Road (E)	550.000	0.000	0.000

## Vehicle Mix

### Heavy Vehicle proportion

		To		
From		A - Woolwich Road (W)	B - Gallions Road	C - Woolwich Road (E)
	A - Woolwich Road (W)	0	1	9
	B - Gallions Road	0	0	2
	C - Woolwich Road (E)	14	0	0

## Results

### Results Summary for whole modelled period

Stream	Max RFC	Max delay (s)	Max Queue (Veh)	Max LOS
B-C	0.11	7.49	0.1	A
B-A	0.00	0.00	0.0	A
C-AB	0.00	0.00	0.0	A
C-A				
A-B				
A-C				

### Main Results for each time segment

#### Main results: (08:00-08:15)

Stream	Total Demand (Veh/hr)	Capacity (Veh/hr)	RFC	Throughput (Veh/hr)	End queue (Veh)	Delay (s)	LOS
B-C	40.65	600.89	0.068	40.37	0.1	6.420	A
B-A	0.00	343.06	0.000	0.00	0.0	0.000	A
C-AB	0.00	428.26	0.000	0.00	0.0	0.000	A
C-A	414.07			414.07			
A-B	111.42			111.42			
A-C	458.49			458.49			

#### Main results: (08:15-08:30)

Stream	Total Demand (Veh/hr)	Capacity (Veh/hr)	RFC	Throughput (Veh/hr)	End queue (Veh)	Delay (s)	LOS
B-C	48.54	575.42	0.084	48.47	0.1	6.831	A
B-A	0.00	312.62	0.000	0.00	0.0	0.000	A
C-AB	0.00	407.27	0.000	0.00	0.0	0.000	A
C-A	494.44			494.44			
A-B	133.05			133.05			
A-C	547.48			547.48			

**Main results: (08:30-08:45)**

Stream	Total Demand (Veh/hr)	Capacity (Veh/hr)	RFC	Throughput (Veh/hr)	End queue (Veh)	Delay (s)	LOS
B-C	59.46	540.20	0.110	59.33	0.1	7.484	A
B-A	0.00	270.53	0.000	0.00	0.0	0.000	A
C-AB	0.00	378.24	0.000	0.00	0.0	0.000	A
C-A	605.56			605.56			
A-B	162.95			162.95			
A-C	670.52			670.52			

**Main results: (08:45-09:00)**

Stream	Total Demand (Veh/hr)	Capacity (Veh/hr)	RFC	Throughput (Veh/hr)	End queue (Veh)	Delay (s)	LOS
B-C	59.46	540.20	0.110	59.45	0.1	7.487	A
B-A	0.00	270.53	0.000	0.00	0.0	0.000	A
C-AB	0.00	378.24	0.000	0.00	0.0	0.000	A
C-A	605.56			605.56			
A-B	162.95			162.95			
A-C	670.52			670.52			

**Main results: (09:00-09:15)**

Stream	Total Demand (Veh/hr)	Capacity (Veh/hr)	RFC	Throughput (Veh/hr)	End queue (Veh)	Delay (s)	LOS
B-C	48.54	575.42	0.084	48.67	0.1	6.835	A
B-A	0.00	312.62	0.000	0.00	0.0	0.000	A
C-AB	0.00	407.27	0.000	0.00	0.0	0.000	A
C-A	494.44			494.44			
A-B	133.05			133.05			
A-C	547.48			547.48			

**Main results: (09:15-09:30)**

Stream	Total Demand (Veh/hr)	Capacity (Veh/hr)	RFC	Throughput (Veh/hr)	End queue (Veh)	Delay (s)	LOS
B-C	40.65	600.89	0.068	40.73	0.1	6.426	A
B-A	0.00	343.06	0.000	0.00	0.0	0.000	A
C-AB	0.00	428.26	0.000	0.00	0.0	0.000	A
C-A	414.07			414.07			
A-B	111.42			111.42			
A-C	458.49			458.49			

# 2016 Baseline, PM

## Data Errors and Warnings

*No errors or warnings*

## Analysis Set Details

ID	Network flow scaling factor (%)
A1	100.000

# Junction Network

## Junctions

Junction	Name	Junction Type	Major road direction	Junction Delay (s)	Junction LOS
1 - untitled	untitled	T-Junction	Two-way	1.00	A

## Junction Network Options

*[same as above]*

# Arms

## Arms

*[same as above]*

## Major Arm Geometry

*[same as above]*

## Minor Arm Geometry

*[same as above]*

## Slope / Intercept / Capacity

*[same as above]*

# Traffic Demand

## Demand Set Details

ID	Scenario name	Time Period name	Traffic profile type	Model start time (HH:mm)	Model finish time (HH:mm)	Time segment length (min)
D2	2016 Baseline	PM	ONE HOUR	17:00	18:30	15

Vehicle mix varies over turn	Vehicle mix varies over entry	Vehicle mix source	PCU Factor for a HV (PCU)
✓	✓	HV Percentages	2.00

## Demand overview (Traffic)

Arm	Linked arm	Use O-D data	Average Demand (Veh/hr)	Scaling Factor (%)
A - Woolwich Road (W)		✓	653.00	100.000
B - Gallions Road		✓	174.00	100.000
C - Woolwich Road (E)		✓	665.00	100.000

## Origin-Destination Data

### Demand (Veh/hr)

		To		
		A - Woolwich Road (W)	B - Gallions Road	C - Woolwich Road (E)
From	A - Woolwich Road (W)	0.000	216.000	437.000
	B - Gallions Road	0.000	0.000	174.000
	C - Woolwich Road (E)	665.000	0.000	0.000

## Vehicle Mix

### Heavy Vehicle proportion

		To		
		A - Woolwich Road (W)	B - Gallions Road	C - Woolwich Road (E)
From	A - Woolwich Road (W)	0	0	7
	B - Gallions Road	0	0	0
	C - Woolwich Road (E)	4	0	0

## Results

### Results Summary for whole modelled period

Stream	Max RFC	Max delay (s)	Max Queue (Veh)	Max LOS
B-C	0.32	8.88	0.5	A
B-A	0.00	0.00	0.0	A
C-AB	0.00	0.00	0.0	A
C-A				
A-B				
A-C				

## Main Results for each time segment

### Main results: (17:00-17:15)

Stream	Total Demand (Veh/hr)	Capacity (Veh/hr)	RFC	Throughput (Veh/hr)	End queue (Veh)	Delay (s)	LOS
B-C	131.00	644.36	0.203	129.99	0.3	6.987	A
B-A	0.00	361.20	0.000	0.00	0.0	0.000	A
C-AB	0.00	467.35	0.000	0.00	0.0	0.000	A
C-A	500.65			500.65			
A-B	162.62			162.62			
A-C	329.00			329.00			

### Main results: (17:15-17:30)

Stream	Total Demand (Veh/hr)	Capacity (Veh/hr)	RFC	Throughput (Veh/hr)	End queue (Veh)	Delay (s)	LOS
B-C	156.42	624.48	0.250	156.11	0.3	7.682	A
B-A	0.00	334.28	0.000	0.00	0.0	0.000	A
C-AB	0.00	448.84	0.000	0.00	0.0	0.000	A
C-A	597.82			597.82			
A-B	194.18			194.18			
A-C	392.85			392.85			

### Main results: (17:30-17:45)

Stream	Total Demand (Veh/hr)	Capacity (Veh/hr)	RFC	Throughput (Veh/hr)	End queue (Veh)	Delay (s)	LOS
B-C	191.58	597.01	0.321	191.04	0.5	8.856	A
B-A	0.00	297.06	0.000	0.00	0.0	0.000	A
C-AB	0.00	423.24	0.000	0.00	0.0	0.000	A
C-A	732.18			732.18			
A-B	237.82			237.82			
A-C	481.15			481.15			

### Main results: (17:45-18:00)

Stream	Total Demand (Veh/hr)	Capacity (Veh/hr)	RFC	Throughput (Veh/hr)	End queue (Veh)	Delay (s)	LOS
B-C	191.58	597.01	0.321	191.56	0.5	8.879	A
B-A	0.00	297.06	0.000	0.00	0.0	0.000	A
C-AB	0.00	423.24	0.000	0.00	0.0	0.000	A
C-A	732.18			732.18			
A-B	237.82			237.82			
A-C	481.15			481.15			

### Main results: (18:00-18:15)

Stream	Total Demand (Veh/hr)	Capacity (Veh/hr)	RFC	Throughput (Veh/hr)	End queue (Veh)	Delay (s)	LOS
B-C	156.42	624.48	0.250	156.95	0.3	7.708	A
B-A	0.00	334.28	0.000	0.00	0.0	0.000	A
C-AB	0.00	448.84	0.000	0.00	0.0	0.000	A
C-A	597.82			597.82			
A-B	194.18			194.18			
A-C	392.85			392.85			

**Main results: (18:15-18:30)**

Stream	Total Demand (Veh/hr)	Capacity (Veh/hr)	RFC	Throughput (Veh/hr)	End queue (Veh)	Delay (s)	LOS
B-C	131.00	644.36	0.203	131.32	0.3	7.020	A
B-A	0.00	361.20	0.000	0.00	0.0	0.000	A
C-AB	0.00	467.35	0.000	0.00	0.0	0.000	A
C-A	500.65			500.65			
A-B	162.62			162.62			
A-C	329.00			329.00			

# Baseline Plus Proposed Development, AM

## Data Errors and Warnings

*No errors or warnings*

## Analysis Set Details

ID	Network flow scaling factor (%)
A1	100.000

# Junction Network

## Junctions

Junction	Name	Junction Type	Major road direction	Junction Delay (s)	Junction LOS
1 - untitled	untitled	T-Junction	Two-way	0.28	A

## Junction Network Options

*[same as above]*

# Arms

## Arms

*[same as above]*

## Major Arm Geometry

*[same as above]*

## Minor Arm Geometry

*[same as above]*

## Slope / Intercept / Capacity

*[same as above]*

# Traffic Demand

## Demand Set Details

ID	Scenario name	Time Period name	Traffic profile type	Model start time (HH:mm)	Model finish time (HH:mm)	Time segment length (min)
D3	Baseline Plus Proposed Development	AM	ONE HOUR	08:00	09:30	15

Vehicle mix varies over turn	Vehicle mix varies over entry	Vehicle mix source	PCU Factor for a HV (PCU)
✓	✓	HV Percentages	2.00

## Demand overview (Traffic)

Arm	Linked arm	Use O-D data	Average Demand (Veh/hr)	Scaling Factor (%)
A - Woolwich Road (W)		✓	755.00	100.000
B - Gallions Road		✓	54.00	100.000
C - Woolwich Road (E)		✓	550.00	100.000

## Origin-Destination Data

### Demand (Veh/hr)

		To		
		A - Woolwich Road (W)	B - Gallions Road	C - Woolwich Road (E)
From	A - Woolwich Road (W)	0.000	146.000	609.000
	B - Gallions Road	0.000	0.000	54.000
	C - Woolwich Road (E)	550.000	0.000	0.000

## Vehicle Mix

### Heavy Vehicle proportion

		To		
		A - Woolwich Road (W)	B - Gallions Road	C - Woolwich Road (E)
From	A - Woolwich Road (W)	0	1	9
	B - Gallions Road	0	0	2
	C - Woolwich Road (E)	14	0	0

## Results

### Results Summary for whole modelled period

Stream	Max RFC	Max delay (s)	Max Queue (Veh)	Max LOS
B-C	0.11	7.48	0.1	A
B-A	0.00	0.00	0.0	A
C-AB	0.00	0.00	0.0	A
C-A				
A-B				
A-C				

## Main Results for each time segment

### Main results: (08:00-08:15)

Stream	Total Demand (Veh/hr)	Capacity (Veh/hr)	RFC	Throughput (Veh/hr)	End queue (Veh)	Delay (s)	LOS
B-C	40.65	601.03	0.068	40.37	0.1	6.418	A
B-A	0.00	343.17	0.000	0.00	0.0	0.000	A
C-AB	0.00	428.53	0.000	0.00	0.0	0.000	A
C-A	414.07			414.07			
A-B	109.92			109.92			
A-C	458.49			458.49			

### Main results: (08:15-08:30)

Stream	Total Demand (Veh/hr)	Capacity (Veh/hr)	RFC	Throughput (Veh/hr)	End queue (Veh)	Delay (s)	LOS
B-C	48.54	575.59	0.084	48.47	0.1	6.829	A
B-A	0.00	312.75	0.000	0.00	0.0	0.000	A
C-AB	0.00	407.59	0.000	0.00	0.0	0.000	A
C-A	494.44			494.44			
A-B	131.25			131.25			
A-C	547.48			547.48			

### Main results: (08:30-08:45)

Stream	Total Demand (Veh/hr)	Capacity (Veh/hr)	RFC	Throughput (Veh/hr)	End queue (Veh)	Delay (s)	LOS
B-C	59.46	540.42	0.110	59.33	0.1	7.481	A
B-A	0.00	270.69	0.000	0.00	0.0	0.000	A
C-AB	0.00	378.63	0.000	0.00	0.0	0.000	A
C-A	605.56			605.56			
A-B	160.75			160.75			
A-C	670.52			670.52			

### Main results: (08:45-09:00)

Stream	Total Demand (Veh/hr)	Capacity (Veh/hr)	RFC	Throughput (Veh/hr)	End queue (Veh)	Delay (s)	LOS
B-C	59.46	540.42	0.110	59.45	0.1	7.484	A
B-A	0.00	270.69	0.000	0.00	0.0	0.000	A
C-AB	0.00	378.63	0.000	0.00	0.0	0.000	A
C-A	605.56			605.56			
A-B	160.75			160.75			
A-C	670.52			670.52			

### Main results: (09:00-09:15)

Stream	Total Demand (Veh/hr)	Capacity (Veh/hr)	RFC	Throughput (Veh/hr)	End queue (Veh)	Delay (s)	LOS
B-C	48.54	575.59	0.084	48.67	0.1	6.832	A
B-A	0.00	312.75	0.000	0.00	0.0	0.000	A
C-AB	0.00	407.59	0.000	0.00	0.0	0.000	A
C-A	494.44			494.44			
A-B	131.25			131.25			
A-C	547.48			547.48			

**Main results: (09:15-09:30)**

Stream	Total Demand (Veh/hr)	Capacity (Veh/hr)	RFC	Throughput (Veh/hr)	End queue (Veh)	Delay (s)	LOS
B-C	40.65	601.03	0.068	40.73	0.1	6.427	A
B-A	0.00	343.17	0.000	0.00	0.0	0.000	A
C-AB	0.00	428.53	0.000	0.00	0.0	0.000	A
C-A	414.07			414.07			
A-B	109.92			109.92			
A-C	458.49			458.49			

# Baseline Plus Proposed Development, PM

## Data Errors and Warnings

*No errors or warnings*

## Analysis Set Details

ID	Network flow scaling factor (%)
A1	100.000

# Junction Network

## Junctions

Junction	Name	Junction Type	Major road direction	Junction Delay (s)	Junction LOS
1 - untitled	untitled	T-Junction	Two-way	1.00	A

## Junction Network Options

*[same as above]*

# Arms

## Arms

*[same as above]*

## Major Arm Geometry

*[same as above]*

## Minor Arm Geometry

*[same as above]*

## Slope / Intercept / Capacity

*[same as above]*

# Traffic Demand

## Demand Set Details

ID	Scenario name	Time Period name	Traffic profile type	Model start time (HH:mm)	Model finish time (HH:mm)	Time segment length (min)
D4	Baseline Plus Proposed Development	PM	ONE HOUR	17:00	18:30	15

Vehicle mix varies over turn	Vehicle mix varies over entry	Vehicle mix source	PCU Factor for a HV (PCU)
✓	✓	HV Percentages	2.00

## Demand overview (Traffic)

Arm	Linked arm	Use O-D data	Average Demand (Veh/hr)	Scaling Factor (%)
A - Woolwich Road (W)		✓	659.00	100.000
B - Gallions Road		✓	174.00	100.000
C - Woolwich Road (E)		✓	665.00	100.000

## Origin-Destination Data

### Demand (Veh/hr)

From	To			
		A - Woolwich Road (W)	B - Gallions Road	C - Woolwich Road (E)
A - Woolwich Road (W)		0.000	219.000	440.000
B - Gallions Road		0.000	0.000	174.000
C - Woolwich Road (E)		665.000	0.000	0.000

## Vehicle Mix

### Heavy Vehicle proportion

From	To			
		A - Woolwich Road (W)	B - Gallions Road	C - Woolwich Road (E)
A - Woolwich Road (W)		0	0	7
B - Gallions Road		0	0	0
C - Woolwich Road (E)		4	0	0

## Results

### Results Summary for whole modelled period

Stream	Max RFC	Max delay (s)	Max Queue (Veh)	Max LOS
B-C	0.32	8.90	0.5	A
B-A	0.00	0.00	0.0	A
C-AB	0.00	0.00	0.0	A
C-A				
A-B				
A-C				

## Main Results for each time segment

### Main results: (17:00-17:15)

Stream	Total Demand (Veh/hr)	Capacity (Veh/hr)	RFC	Throughput (Veh/hr)	End queue (Veh)	Delay (s)	LOS
B-C	131.00	643.54	0.204	129.98	0.3	6.999	A
B-A	0.00	360.58	0.000	0.00	0.0	0.000	A
C-AB	0.00	466.48	0.000	0.00	0.0	0.000	A
C-A	500.65			500.65			
A-B	164.87			164.87			
A-C	331.26			331.26			

### Main results: (17:15-17:30)

Stream	Total Demand (Veh/hr)	Capacity (Veh/hr)	RFC	Throughput (Veh/hr)	End queue (Veh)	Delay (s)	LOS
B-C	156.42	623.51	0.251	156.11	0.3	7.696	A
B-A	0.00	333.54	0.000	0.00	0.0	0.000	A
C-AB	0.00	447.80	0.000	0.00	0.0	0.000	A
C-A	597.82			597.82			
A-B	196.88			196.88			
A-C	395.55			395.55			

### Main results: (17:30-17:45)

Stream	Total Demand (Veh/hr)	Capacity (Veh/hr)	RFC	Throughput (Veh/hr)	End queue (Veh)	Delay (s)	LOS
B-C	191.58	595.82	0.322	191.03	0.5	8.880	A
B-A	0.00	296.16	0.000	0.00	0.0	0.000	A
C-AB	0.00	421.98	0.000	0.00	0.0	0.000	A
C-A	732.18			732.18			
A-B	241.12			241.12			
A-C	484.45			484.45			

### Main results: (17:45-18:00)

Stream	Total Demand (Veh/hr)	Capacity (Veh/hr)	RFC	Throughput (Veh/hr)	End queue (Veh)	Delay (s)	LOS
B-C	191.58	595.82	0.322	191.56	0.5	8.905	A
B-A	0.00	296.16	0.000	0.00	0.0	0.000	A
C-AB	0.00	421.98	0.000	0.00	0.0	0.000	A
C-A	732.18			732.18			
A-B	241.12			241.12			
A-C	484.45			484.45			

### Main results: (18:00-18:15)

Stream	Total Demand (Veh/hr)	Capacity (Veh/hr)	RFC	Throughput (Veh/hr)	End queue (Veh)	Delay (s)	LOS
B-C	156.42	623.51	0.251	156.95	0.3	7.724	A
B-A	0.00	333.54	0.000	0.00	0.0	0.000	A
C-AB	0.00	447.80	0.000	0.00	0.0	0.000	A
C-A	597.82			597.82			
A-B	196.88			196.88			
A-C	395.55			395.55			

**Main results: (18:15-18:30)**

Stream	Total Demand (Veh/hr)	Capacity (Veh/hr)	RFC	Throughput (Veh/hr)	End queue (Veh)	Delay (s)	LOS
B-C	131.00	643.54	0.204	131.32	0.3	7.031	A
B-A	0.00	360.58	0.000	0.00	0.0	0.000	A
C-AB	0.00	466.48	0.000	0.00	0.0	0.000	A
C-A	500.65			500.65			
A-B	164.87			164.87			
A-C	331.26			331.26			

# Baseline Plus Other Cumulative Developments, AM

## Data Errors and Warnings

*No errors or warnings*

## Analysis Set Details

ID	Network flow scaling factor (%)
A1	100.000

# Junction Network

## Junctions

Junction	Name	Junction Type	Major road direction	Junction Delay (s)	Junction LOS
1 - untitled	untitled	T-Junction	Two-way	0.27	A

## Junction Network Options

*[same as above]*

# Arms

## Arms

*[same as above]*

## Major Arm Geometry

*[same as above]*

## Minor Arm Geometry

*[same as above]*

## Slope / Intercept / Capacity

*[same as above]*

# Traffic Demand

## Demand Set Details

ID	Scenario name	Time Period name	Traffic profile type	Model start time (HH:mm)	Model finish time (HH:mm)	Time segment length (min)
D5	Baseline Plus Other Cumulative Developments	AM	ONE HOUR	08:00	09:30	15

Vehicle mix varies over turn	Vehicle mix varies over entry	Vehicle mix source	PCU Factor for a HV (PCU)
✓	✓	HV Percentages	2.00

## Demand overview (Traffic)

Arm	Linked arm	Use O-D data	Average Demand (Veh/hr)	Scaling Factor (%)
A - Woolwich Road (W)		✓	839.00	100.000
B - Gallions Road		✓	54.00	100.000
C - Woolwich Road (E)		✓	590.00	100.000

## Origin-Destination Data

### Demand (Veh/hr)

From	To			
		A - Woolwich Road (W)	B - Gallions Road	C - Woolwich Road (E)
A - Woolwich Road (W)		0.000	148.000	691.000
B - Gallions Road		0.000	0.000	54.000
C - Woolwich Road (E)		590.000	0.000	0.000

## Vehicle Mix

### Heavy Vehicle proportion

From	To			
		A - Woolwich Road (W)	B - Gallions Road	C - Woolwich Road (E)
A - Woolwich Road (W)		0	1	8
B - Gallions Road		0	0	2
C - Woolwich Road (E)		13	0	0

## Results

### Results Summary for whole modelled period

Stream	Max RFC	Max delay (s)	Max Queue (Veh)	Max LOS
B-C	0.11	7.84	0.1	A
B-A	0.00	0.00	0.0	A
C-AB	0.00	0.00	0.0	A
C-A				
A-B				
A-C				

## Main Results for each time segment

### Main results: (08:00-08:15)

Stream	Total Demand (Veh/hr)	Capacity (Veh/hr)	RFC	Throughput (Veh/hr)	End queue (Veh)	Delay (s)	LOS
B-C	40.65	585.92	0.069	40.36	0.1	6.596	A
B-A	0.00	327.98	0.000	0.00	0.0	0.000	A
C-AB	0.00	419.25	0.000	0.00	0.0	0.000	A
C-A	444.18			444.18			
A-B	111.42			111.42			
A-C	520.22			520.22			

### Main results: (08:15-08:30)

Stream	Total Demand (Veh/hr)	Capacity (Veh/hr)	RFC	Throughput (Veh/hr)	End queue (Veh)	Delay (s)	LOS
B-C	48.54	557.54	0.087	48.46	0.1	7.071	A
B-A	0.00	294.61	0.000	0.00	0.0	0.000	A
C-AB	0.00	396.02	0.000	0.00	0.0	0.000	A
C-A	530.40			530.40			
A-B	133.05			133.05			
A-C	621.19			621.19			

### Main results: (08:30-08:45)

Stream	Total Demand (Veh/hr)	Capacity (Veh/hr)	RFC	Throughput (Veh/hr)	End queue (Veh)	Delay (s)	LOS
B-C	59.46	518.31	0.115	59.32	0.1	7.840	A
B-A	0.00	248.47	0.000	0.00	0.0	0.000	A
C-AB	0.00	363.90	0.000	0.00	0.0	0.000	A
C-A	649.60			649.60			
A-B	162.95			162.95			
A-C	760.81			760.81			

### Main results: (08:45-09:00)

Stream	Total Demand (Veh/hr)	Capacity (Veh/hr)	RFC	Throughput (Veh/hr)	End queue (Veh)	Delay (s)	LOS
B-C	59.46	518.31	0.115	59.45	0.1	7.845	A
B-A	0.00	248.47	0.000	0.00	0.0	0.000	A
C-AB	0.00	363.90	0.000	0.00	0.0	0.000	A
C-A	649.60			649.60			
A-B	162.95			162.95			
A-C	760.81			760.81			

### Main results: (09:00-09:15)

Stream	Total Demand (Veh/hr)	Capacity (Veh/hr)	RFC	Throughput (Veh/hr)	End queue (Veh)	Delay (s)	LOS
B-C	48.54	557.54	0.087	48.68	0.1	7.078	A
B-A	0.00	294.61	0.000	0.00	0.0	0.000	A
C-AB	0.00	396.02	0.000	0.00	0.0	0.000	A
C-A	530.40			530.40			
A-B	133.05			133.05			
A-C	621.19			621.19			

**Main results: (09:15-09:30)**

Stream	Total Demand (Veh/hr)	Capacity (Veh/hr)	RFC	Throughput (Veh/hr)	End queue (Veh)	Delay (s)	LOS
B-C	40.65	585.92	0.069	40.74	0.1	6.606	A
B-A	0.00	327.98	0.000	0.00	0.0	0.000	A
C-AB	0.00	419.25	0.000	0.00	0.0	0.000	A
C-A	444.18			444.18			
A-B	111.42			111.42			
A-C	520.22			520.22			

# Baseline Plus Other Cumulative Developments, PM

## Data Errors and Warnings

*No errors or warnings*

## Analysis Set Details

ID	Network flow scaling factor (%)
A1	100.000

# Junction Network

## Junctions

Junction	Name	Junction Type	Major road direction	Junction Delay (s)	Junction LOS
1 - untitled	untitled	T-Junction	Two-way	0.93	A

## Junction Network Options

*[same as above]*

# Arms

## Arms

*[same as above]*

## Major Arm Geometry

*[same as above]*

## Minor Arm Geometry

*[same as above]*

## Slope / Intercept / Capacity

*[same as above]*

# Traffic Demand

## Demand Set Details

ID	Scenario name	Time Period name	Traffic profile type	Model start time (HH:mm)	Model finish time (HH:mm)	Time segment length (min)
D6	Baseline Plus Other Cumulative Developments	PM	ONE HOUR	17:00	18:30	15

Vehicle mix varies over turn	Vehicle mix varies over entry	Vehicle mix source	PCU Factor for a HV (PCU)
✓	✓	HV Percentages	2.00

## Demand overview (Traffic)

Arm	Linked arm	Use O-D data	Average Demand (Veh/hr)	Scaling Factor (%)
A - Woolwich Road (W)		✓	706.00	100.000
B - Gallions Road		✓	174.00	100.000
C - Woolwich Road (E)		✓	772.00	100.000

## Origin-Destination Data

### Demand (Veh/hr)

From	To			
		A - Woolwich Road (W)	B - Gallions Road	C - Woolwich Road (E)
A - Woolwich Road (W)		0.000	216.000	490.000
B - Gallions Road		0.000	0.000	174.000
C - Woolwich Road (E)		772.000	0.000	0.000

## Vehicle Mix

### Heavy Vehicle proportion

From	To			
		A - Woolwich Road (W)	B - Gallions Road	C - Woolwich Road (E)
A - Woolwich Road (W)		0	0	6
B - Gallions Road		0	0	0
C - Woolwich Road (E)		4	0	0

## Results

### Results Summary for whole modelled period

Stream	Max RFC	Max delay (s)	Max Queue (Veh)	Max LOS
B-C	0.33	9.20	0.5	A
B-A	0.00	0.00	0.0	A
C-AB	0.00	0.00	0.0	A
C-A				
A-B				
A-C				

## Main Results for each time segment

### Main results: (17:00-17:15)

Stream	Total Demand (Veh/hr)	Capacity (Veh/hr)	RFC	Throughput (Veh/hr)	End queue (Veh)	Delay (s)	LOS
B-C	131.00	634.77	0.206	129.97	0.3	7.117	A
B-A	0.00	344.10	0.000	0.00	0.0	0.000	A
C-AB	0.00	460.12	0.000	0.00	0.0	0.000	A
C-A	581.20			581.20			
A-B	162.62			162.62			
A-C	368.90			368.90			

### Main results: (17:15-17:30)

Stream	Total Demand (Veh/hr)	Capacity (Veh/hr)	RFC	Throughput (Veh/hr)	End queue (Veh)	Delay (s)	LOS
B-C	156.42	613.03	0.255	156.10	0.3	7.873	A
B-A	0.00	313.86	0.000	0.00	0.0	0.000	A
C-AB	0.00	440.21	0.000	0.00	0.0	0.000	A
C-A	694.01			694.01			
A-B	194.18			194.18			
A-C	440.50			440.50			

### Main results: (17:30-17:45)

Stream	Total Demand (Veh/hr)	Capacity (Veh/hr)	RFC	Throughput (Veh/hr)	End queue (Veh)	Delay (s)	LOS
B-C	191.58	582.98	0.329	191.00	0.5	9.170	A
B-A	0.00	272.05	0.000	0.00	0.0	0.000	A
C-AB	0.00	412.67	0.000	0.00	0.0	0.000	A
C-A	849.99			849.99			
A-B	237.82			237.82			
A-C	539.50			539.50			

### Main results: (17:45-18:00)

Stream	Total Demand (Veh/hr)	Capacity (Veh/hr)	RFC	Throughput (Veh/hr)	End queue (Veh)	Delay (s)	LOS
B-C	191.58	582.98	0.329	191.56	0.5	9.197	A
B-A	0.00	272.05	0.000	0.00	0.0	0.000	A
C-AB	0.00	412.67	0.000	0.00	0.0	0.000	A
C-A	849.99			849.99			
A-B	237.82			237.82			
A-C	539.50			539.50			

### Main results: (18:00-18:15)

Stream	Total Demand (Veh/hr)	Capacity (Veh/hr)	RFC	Throughput (Veh/hr)	End queue (Veh)	Delay (s)	LOS
B-C	156.42	613.03	0.255	156.98	0.3	7.903	A
B-A	0.00	313.86	0.000	0.00	0.0	0.000	A
C-AB	0.00	440.21	0.000	0.00	0.0	0.000	A
C-A	694.01			694.01			
A-B	194.18			194.18			
A-C	440.50			440.50			

**Main results: (18:15-18:30)**

Stream	Total Demand (Veh/hr)	Capacity (Veh/hr)	RFC	Throughput (Veh/hr)	End queue (Veh)	Delay (s)	LOS
B-C	131.00	634.77	0.206	131.33	0.3	7.157	A
B-A	0.00	344.10	0.000	0.00	0.0	0.000	A
C-AB	0.00	460.12	0.000	0.00	0.0	0.000	A
C-A	581.20			581.20			
A-B	162.62			162.62			
A-C	368.90			368.90			

# Cumulative Development Scenario, AM

## Data Errors and Warnings

*No errors or warnings*

## Analysis Set Details

ID	Network flow scaling factor (%)
A1	100.000

# Junction Network

## Junctions

Junction	Name	Junction Type	Major road direction	Junction Delay (s)	Junction LOS
1 - untitled	untitled	T-Junction	Two-way	0.27	A

## Junction Network Options

*[same as above]*

# Arms

## Arms

*[same as above]*

## Major Arm Geometry

*[same as above]*

## Minor Arm Geometry

*[same as above]*

## Slope / Intercept / Capacity

*[same as above]*

# Traffic Demand

## Demand Set Details

ID	Scenario name	Time Period name	Traffic profile type	Model start time (HH:mm)	Model finish time (HH:mm)	Time segment length (min)
D7	Cumulative Development Scenario	AM	ONE HOUR	08:00	09:30	15

Vehicle mix varies over turn	Vehicle mix varies over entry	Vehicle mix source	PCU Factor for a HV (PCU)
✓	✓	HV Percentages	2.00

## Demand overview (Traffic)

Arm	Linked arm	Use O-D data	Average Demand (Veh/hr)	Scaling Factor (%)
A - Woolwich Road (W)		✓	838.00	100.000
B - Gallions Road		✓	54.00	100.000
C - Woolwich Road (E)		✓	590.00	100.000

## Origin-Destination Data

### Demand (Veh/hr)

From	To			
		A - Woolwich Road (W)	B - Gallions Road	C - Woolwich Road (E)
A - Woolwich Road (W)		0.000	146.000	692.000
B - Gallions Road		0.000	0.000	54.000
C - Woolwich Road (E)		590.000	0.000	0.000

## Vehicle Mix

### Heavy Vehicle proportion

From	To			
		A - Woolwich Road (W)	B - Gallions Road	C - Woolwich Road (E)
A - Woolwich Road (W)		0	1	8
B - Gallions Road		0	0	2
C - Woolwich Road (E)		13	0	0

## Results

### Results Summary for whole modelled period

Stream	Max RFC	Max delay (s)	Max Queue (Veh)	Max LOS
B-C	0.11	7.85	0.1	A
B-A	0.00	0.00	0.0	A
C-AB	0.00	0.00	0.0	A
C-A				
A-B				
A-C				

## Main Results for each time segment

### Main results: (08:00-08:15)

Stream	Total Demand (Veh/hr)	Capacity (Veh/hr)	RFC	Throughput (Veh/hr)	End queue (Veh)	Delay (s)	LOS
B-C	40.65	585.87	0.069	40.36	0.1	6.596	A
B-A	0.00	327.94	0.000	0.00	0.0	0.000	A
C-AB	0.00	419.38	0.000	0.00	0.0	0.000	A
C-A	444.18			444.18			
A-B	109.92			109.92			
A-C	520.97			520.97			

### Main results: (08:15-08:30)

Stream	Total Demand (Veh/hr)	Capacity (Veh/hr)	RFC	Throughput (Veh/hr)	End queue (Veh)	Delay (s)	LOS
B-C	48.54	557.48	0.087	48.46	0.1	7.072	A
B-A	0.00	294.56	0.000	0.00	0.0	0.000	A
C-AB	0.00	396.17	0.000	0.00	0.0	0.000	A
C-A	530.40			530.40			
A-B	131.25			131.25			
A-C	622.09			622.09			

### Main results: (08:30-08:45)

Stream	Total Demand (Veh/hr)	Capacity (Veh/hr)	RFC	Throughput (Veh/hr)	End queue (Veh)	Delay (s)	LOS
B-C	59.46	518.24	0.115	59.32	0.1	7.841	A
B-A	0.00	248.41	0.000	0.00	0.0	0.000	A
C-AB	0.00	364.09	0.000	0.00	0.0	0.000	A
C-A	649.60			649.60			
A-B	160.75			160.75			
A-C	761.91			761.91			

### Main results: (08:45-09:00)

Stream	Total Demand (Veh/hr)	Capacity (Veh/hr)	RFC	Throughput (Veh/hr)	End queue (Veh)	Delay (s)	LOS
B-C	59.46	518.24	0.115	59.45	0.1	7.846	A
B-A	0.00	248.41	0.000	0.00	0.0	0.000	A
C-AB	0.00	364.09	0.000	0.00	0.0	0.000	A
C-A	649.60			649.60			
A-B	160.75			160.75			
A-C	761.91			761.91			

### Main results: (09:00-09:15)

Stream	Total Demand (Veh/hr)	Capacity (Veh/hr)	RFC	Throughput (Veh/hr)	End queue (Veh)	Delay (s)	LOS
B-C	48.54	557.48	0.087	48.68	0.1	7.076	A
B-A	0.00	294.56	0.000	0.00	0.0	0.000	A
C-AB	0.00	396.17	0.000	0.00	0.0	0.000	A
C-A	530.40			530.40			
A-B	131.25			131.25			
A-C	622.09			622.09			

**Main results: (09:15-09:30)**

Stream	Total Demand (Veh/hr)	Capacity (Veh/hr)	RFC	Throughput (Veh/hr)	End queue (Veh)	Delay (s)	LOS
B-C	40.65	585.87	0.069	40.74	0.1	6.606	A
B-A	0.00	327.94	0.000	0.00	0.0	0.000	A
C-AB	0.00	419.38	0.000	0.00	0.0	0.000	A
C-A	444.18			444.18			
A-B	109.92			109.92			
A-C	520.97			520.97			

# Cumulative Development Scenario, PM

## Data Errors and Warnings

*No errors or warnings*

## Analysis Set Details

ID	Network flow scaling factor (%)
A1	100.000

# Junction Network

## Junctions

Junction	Name	Junction Type	Major road direction	Junction Delay (s)	Junction LOS
1 - untitled	untitled	T-Junction	Two-way	0.93	A

## Junction Network Options

*[same as above]*

# Arms

## Arms

*[same as above]*

## Major Arm Geometry

*[same as above]*

## Minor Arm Geometry

*[same as above]*

## Slope / Intercept / Capacity

*[same as above]*

# Traffic Demand

## Demand Set Details

ID	Scenario name	Time Period name	Traffic profile type	Model start time (HH:mm)	Model finish time (HH:mm)	Time segment length (min)
D8	Cumulative Development Scenario	PM	ONE HOUR	17:00	18:30	15

Vehicle mix varies over turn	Vehicle mix varies over entry	Vehicle mix source	PCU Factor for a HV (PCU)
✓	✓	HV Percentages	2.00

## Demand overview (Traffic)

Arm	Linked arm	Use O-D data	Average Demand (Veh/hr)	Scaling Factor (%)
A - Woolwich Road (W)		✓	712.00	100.000
B - Gallions Road		✓	174.00	100.000
C - Woolwich Road (E)		✓	772.00	100.000

## Origin-Destination Data

### Demand (Veh/hr)

From	To			
		A - Woolwich Road (W)	B - Gallions Road	C - Woolwich Road (E)
A - Woolwich Road (W)		0.000	219.000	493.000
B - Gallions Road		0.000	0.000	174.000
C - Woolwich Road (E)		772.000	0.000	0.000

## Vehicle Mix

### Heavy Vehicle proportion

From	To			
		A - Woolwich Road (W)	B - Gallions Road	C - Woolwich Road (E)
A - Woolwich Road (W)		0	0	6
B - Gallions Road		0	0	0
C - Woolwich Road (E)		4	0	0

## Results

### Results Summary for whole modelled period

Stream	Max RFC	Max delay (s)	Max Queue (Veh)	Max LOS
B-C	0.33	9.22	0.5	A
B-A	0.00	0.00	0.0	A
C-AB	0.00	0.00	0.0	A
C-A				
A-B				
A-C				

## Main Results for each time segment

### Main results: (17:00-17:15)

Stream	Total Demand (Veh/hr)	Capacity (Veh/hr)	RFC	Throughput (Veh/hr)	End queue (Veh)	Delay (s)	LOS
B-C	131.00	633.96	0.207	129.96	0.3	7.128	A
B-A	0.00	343.49	0.000	0.00	0.0	0.000	A
C-AB	0.00	459.26	0.000	0.00	0.0	0.000	A
C-A	581.20			581.20			
A-B	164.87			164.87			
A-C	371.16			371.16			

### Main results: (17:15-17:30)

Stream	Total Demand (Veh/hr)	Capacity (Veh/hr)	RFC	Throughput (Veh/hr)	End queue (Veh)	Delay (s)	LOS
B-C	156.42	612.07	0.256	156.10	0.3	7.889	A
B-A	0.00	313.13	0.000	0.00	0.0	0.000	A
C-AB	0.00	439.18	0.000	0.00	0.0	0.000	A
C-A	694.01			694.01			
A-B	196.88			196.88			
A-C	443.20			443.20			

### Main results: (17:30-17:45)

Stream	Total Demand (Veh/hr)	Capacity (Veh/hr)	RFC	Throughput (Veh/hr)	End queue (Veh)	Delay (s)	LOS
B-C	191.58	581.80	0.329	191.00	0.5	9.198	A
B-A	0.00	271.16	0.000	0.00	0.0	0.000	A
C-AB	0.00	411.41	0.000	0.00	0.0	0.000	A
C-A	849.99			849.99			
A-B	241.12			241.12			
A-C	542.80			542.80			

### Main results: (17:45-18:00)

Stream	Total Demand (Veh/hr)	Capacity (Veh/hr)	RFC	Throughput (Veh/hr)	End queue (Veh)	Delay (s)	LOS
B-C	191.58	581.80	0.329	191.56	0.5	9.225	A
B-A	0.00	271.16	0.000	0.00	0.0	0.000	A
C-AB	0.00	411.41	0.000	0.00	0.0	0.000	A
C-A	849.99			849.99			
A-B	241.12			241.12			
A-C	542.80			542.80			

### Main results: (18:00-18:15)

Stream	Total Demand (Veh/hr)	Capacity (Veh/hr)	RFC	Throughput (Veh/hr)	End queue (Veh)	Delay (s)	LOS
B-C	156.42	612.07	0.256	156.98	0.3	7.920	A
B-A	0.00	313.13	0.000	0.00	0.0	0.000	A
C-AB	0.00	439.18	0.000	0.00	0.0	0.000	A
C-A	694.01			694.01			
A-B	196.88			196.88			
A-C	443.20			443.20			

**Main results: (18:15-18:30)**

Stream	Total Demand (Veh/hr)	Capacity (Veh/hr)	RFC	Throughput (Veh/hr)	End queue (Veh)	Delay (s)	LOS
B-C	131.00	633.96	0.207	131.33	0.3	7.166	A
B-A	0.00	343.49	0.000	0.00	0.0	0.000	A
C-AB	0.00	459.26	0.000	0.00	0.0	0.000	A
C-A	581.20			581.20			
A-B	164.87			164.87			
A-C	371.16			371.16			

**Appendix D**  
**Anchor and Hope Lane/Access**  
**Road PICADY Results**

<b>Junctions 9</b>
<b>PICADY 9 - Priority Intersection Module</b>
Version: 9.0.0.4211 [] © Copyright TRL Limited, 2017
For sales and distribution information, program advice and maintenance, contact TRL: Tel: +44 (0)1344 770758 email: software@trl.co.uk Web: http://www.trlsoftware.co.uk
<b>The users of this computer program for the solution of an engineering problem are in no way relieved of their responsibility for the correctness of the solution</b>

**Filename:** Site 3 - Anchor and Hope Lane-Business Park Access.j9

**Path:** T:\30000\_Projects\30821 Charlton Riverside, Greenwich\Junction modelling\Site 3

**Report generation date:** 04/12/2017 10:06:51

---

### «Cumulative Development Scenario, PM

- »Junction Network
- »Arms
- »Traffic Demand
- »Origin-Destination Data
- »Vehicle Mix
- »Results

## Summary of junction performance

	AM				PM			
	Queue (Veh)	Delay (s)	RFC	LOS	Queue (Veh)	Delay (s)	RFC	LOS
<b>2016 Baseline</b>								
Stream B-C	0.0	6.01	0.04	A	0.2	5.91	0.15	A
Stream B-A	0.0	9.39	0.02	A	0.0	8.44	0.00	A
Stream C-AB	0.1	6.70	0.11	A	0.0	7.69	0.03	A
Stream C-A								
Stream A-B								
Stream A-C								
<b>Baseline Plus Proposed Development</b>								
Stream B-C	0.2	6.18	0.19	A	0.2	5.89	0.15	A
Stream B-A	0.0	9.16	0.01	A	0.0	8.73	0.00	A
Stream C-AB	0.1	6.52	0.09	A	0.2	6.92	0.14	A
Stream C-A								
Stream A-B								
Stream A-C								
<b>Baseline Plus Other Cumulative Developments</b>								
Stream B-C	0.0	6.01	0.04	A	0.2	5.91	0.15	A
Stream B-A	0.0	9.39	0.02	A	0.0	8.44	0.00	A
Stream C-AB	0.1	6.70	0.11	A	0.0	7.69	0.03	A
Stream C-A								
Stream A-B								
Stream A-C								
<b>Cumulative Development Scenario</b>								
Stream B-C	0.2	6.18	0.19	A	0.2	5.89	0.15	A
Stream B-A	0.0	9.16	0.01	A	0.0	8.73	0.00	A
Stream C-AB	0.1	6.52	0.09	A	0.2	6.92	0.14	A
Stream C-A								
Stream A-B								
Stream A-C								

Values shown are the highest values encountered over all time segments. Delay is the maximum value of average delay per arriving vehicle.

## File summary

### File Description

Title	(untitled)
Location	
Site number	
Date	30/08/2016
Version	
Status	(new file)
Identifier	
Client	
Jobnumber	
Enumerator	TPP111"techuser
Description	

### Units

Distance units	Speed units	Traffic units input	Traffic units results	Flow units	Average delay units	Total delay units	Rate of delay units
m	kph	Veh	Veh	perHour	s	-Min	perMin

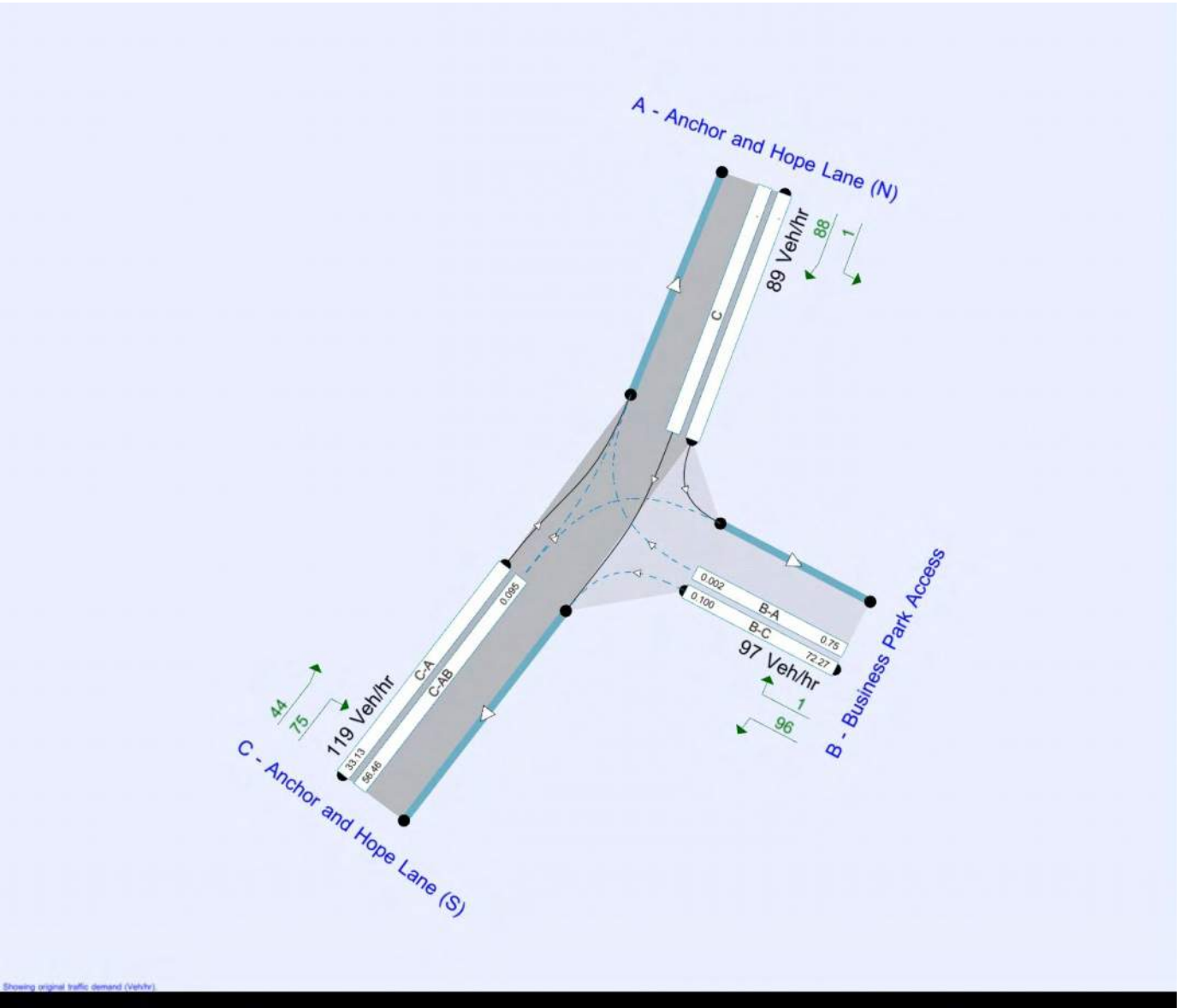

The junction diagram reflects the last run of Junctions.

### Analysis Options

Calculate Queue Percentiles	Calculate residual capacity	RFC Threshold	Average Delay threshold (s)	Queue threshold (PCU)
		0.85	36.00	20.00

### Analysis Set Details

ID	Network flow scaling factor (%)
A1	100.000



### Demand Set Details

ID	Scenario name	Time Period name	Traffic profile type	Model start time (HH:mm)	Model finish time (HH:mm)	Time segment length (min)
D8	Cumulative Development Scenario	PM	ONE HOUR	17:00	18:30	15

# Cumulative Development Scenario, PM

## Data Errors and Warnings

No errors or warnings

## Junction Network

### Junctions

Junction	Name	Junction Type	Major road direction	Junction Delay (s)	Junction LOS
1 - untitled	untitled	T-Junction	Two-way	3.58	A

### Junction Network Options

Driving side	Lighting
Left	Normal/unknown

## Arms

### Arms

Arm	Name	Description	Arm type
A	Anchor and Hope Lane (N)		Major
B	Business Park Access		Minor
C	Anchor and Hope Lane (S)		Major

### Major Arm Geometry

Arm	Width of carriageway (m)	Has kerbed central reserve	Has right turn bay	Visibility for right turn (m)	Blocks?	Blocking queue (PCU)
C - Anchor and Hope Lane (S)	11.35			80.7	✓	5.00

Geometries for Arm C are measured opposite Arm B. Geometries for Arm A (if relevant) are measured opposite Arm D.

### Minor Arm Geometry

Arm	Minor arm type	Width at give-way (m)	Width at 5m (m)	Width at 10m (m)	Width at 15m (m)	Width at 20m (m)	Estimate flare length	Flare length (PCU)	Visibility to left (m)	Visibility to right (m)
B - Business Park Access	One lane plus flare	10.00	6.30	5.10	4.30	4.00	✓	2.00	34	15

## Slope / Intercept / Capacity

### Priority Intersection Slopes and Intercepts

Junction	Stream	Intercept (Veh/hr)	Slope for A-B	Slope for A-C	Slope for C-A	Slope for C-B
1	B-A	453.222	0.063	0.160	0.101	0.229
1	B-C	738.937	0.087	0.220	-	-
1	C-B	620.697	0.185	0.185	-	-

The slopes and intercepts shown above do NOT include any corrections or adjustments.

Streams may be combined, in which case capacity will be adjusted.

Values are shown for the first time segment only; they may differ for subsequent time segments.

## Traffic Demand

Vehicle mix varies over time	Vehicle mix varies over turn	Vehicle mix varies over entry	Vehicle mix source	PCU Factor for a HV (PCU)
✓	✓	✓	HV Percentages	2.00

### Demand overview (Traffic)

Arm	Linked arm	Use O-D data	Average Demand (Veh/hr)	Scaling Factor (%)
A - Anchor and Hope Lane (N)		✓	89.00	100.000
B - Business Park Access		✓	97.00	100.000
C - Anchor and Hope Lane (S)		✓	119.00	100.000

## Origin-Destination Data

### Demand (Veh/hr)

		To		
		A - Anchor and Hope Lane (N)	B - Business Park Access	C - Anchor and Hope Lane (S)
From	A - Anchor and Hope Lane (N)	0.000	1.000	88.000
	B - Business Park Access	1.000	0.000	96.000
	C - Anchor and Hope Lane (S)	44.000	75.000	0.000

## Vehicle Mix

**Heavy Vehicle proportion**

(17:00-17:15)

		To		
		A - Anchor and Hope Lane (N)	B - Business Park Access	C - Anchor and Hope Lane (S)
From	A - Anchor and Hope Lane (N)	0	0	3
	B - Business Park Access	0	0	0
	C - Anchor and Hope Lane (S)	9	2	0

**Heavy Vehicle proportion**

(17:15-17:30)

		To		
		A - Anchor and Hope Lane (N)	B - Business Park Access	C - Anchor and Hope Lane (S)
From	A - Anchor and Hope Lane (N)	0	0	0
	B - Business Park Access	0	0	0
	C - Anchor and Hope Lane (S)	0	0	0

**Heavy Vehicle proportion**

(17:30-17:45)

		To		
		A - Anchor and Hope Lane (N)	B - Business Park Access	C - Anchor and Hope Lane (S)
From	A - Anchor and Hope Lane (N)	0	0	0
	B - Business Park Access	0	0	0
	C - Anchor and Hope Lane (S)	0	0	0

**Heavy Vehicle proportion**

(17:45-18:00)

		To		
		A - Anchor and Hope Lane (N)	B - Business Park Access	C - Anchor and Hope Lane (S)
From	A - Anchor and Hope Lane (N)	0	0	0
	B - Business Park Access	0	0	0
	C - Anchor and Hope Lane (S)	0	0	0

**Heavy Vehicle proportion**

(18:00-18:15)

		To		
		A - Anchor and Hope Lane (N)	B - Business Park Access	C - Anchor and Hope Lane (S)
From	A - Anchor and Hope Lane (N)	0	0	0
	B - Business Park Access	0	0	0
	C - Anchor and Hope Lane (S)	0	0	0

### Heavy Vehicle proportion

(18:15-18:30)

		To		
From		A - Anchor and Hope Lane (N)	B - Business Park Access	C - Anchor and Hope Lane (S)
	A - Anchor and Hope Lane (N)	0	0	0
	B - Business Park Access	0	0	0
	C - Anchor and Hope Lane (S)	0	0	0

## Results

### Results Summary for whole modelled period

Stream	Max RFC	Max delay (s)	Max Queue (Veh)	Max LOS
B-C	0.15	5.89	0.2	A
B-A	0.00	8.73	0.0	A
C-AB	0.14	6.92	0.2	A
C-A				
A-B				
A-C				

### Main Results for each time segment

#### Main results: (17:00-17:15)

Stream	Total Demand (Veh/hr)	Capacity (Veh/hr)	RFC	Throughput (Veh/hr)	End queue (Veh)	Delay (s)	LOS
B-C	72.27	723.56	0.100	71.83	0.1	5.520	A
B-A	0.75	425.40	0.002	0.75	0.0	8.477	A
C-AB	56.46	596.05	0.095	56.05	0.1	6.663	A
C-A	33.13			33.13			
A-B	0.75			0.75			
A-C	66.25			66.25			

#### Main results: (17:15-17:30)

Stream	Total Demand (Veh/hr)	Capacity (Veh/hr)	RFC	Throughput (Veh/hr)	End queue (Veh)	Delay (s)	LOS
B-C	86.30	721.09	0.120	86.20	0.1	5.670	A
B-A	0.90	420.91	0.002	0.90	0.0	8.570	A
C-AB	67.42	605.86	0.111	67.34	0.1	6.752	A
C-A	39.56			39.56			
A-B	0.90			0.90			
A-C	79.11			79.11			

**Main results: (17:30-17:45)**

Stream	Total Demand (Veh/hr)	Capacity (Veh/hr)	RFC	Throughput (Veh/hr)	End queue (Veh)	Delay (s)	LOS
B-C	105.70	717.08	0.147	105.55	0.2	5.885	A
B-A	1.10	413.57	0.003	1.10	0.0	8.727	A
C-AB	82.58	602.62	0.137	82.45	0.2	6.918	A
C-A	48.44			48.44			
A-B	1.10			1.10			
A-C	96.89			96.89			

**Main results: (17:45-18:00)**

Stream	Total Demand (Veh/hr)	Capacity (Veh/hr)	RFC	Throughput (Veh/hr)	End queue (Veh)	Delay (s)	LOS
B-C	105.70	717.08	0.147	105.70	0.2	5.887	A
B-A	1.10	413.54	0.003	1.10	0.0	8.728	A
C-AB	82.58	602.62	0.137	82.57	0.2	6.921	A
C-A	48.44			48.44			
A-B	1.10			1.10			
A-C	96.89			96.89			

**Main results: (18:00-18:15)**

Stream	Total Demand (Veh/hr)	Capacity (Veh/hr)	RFC	Throughput (Veh/hr)	End queue (Veh)	Delay (s)	LOS
B-C	86.30	721.09	0.120	86.44	0.1	5.673	A
B-A	0.90	420.87	0.002	0.90	0.0	8.571	A
C-AB	67.42	605.94	0.111	67.55	0.1	6.687	A
C-A	39.56			39.56			
A-B	0.90			0.90			
A-C	79.11			79.11			

**Main results: (18:15-18:30)**

Stream	Total Demand (Veh/hr)	Capacity (Veh/hr)	RFC	Throughput (Veh/hr)	End queue (Veh)	Delay (s)	LOS
B-C	72.27	724.00	0.100	72.37	0.1	5.527	A
B-A	0.75	426.16	0.002	0.75	0.0	8.463	A
C-AB	56.46	608.33	0.093	56.56	0.1	6.527	A
C-A	33.13			33.13			
A-B	0.75			0.75			
A-C	66.25			66.25			

**Appendix E**  
**Anchor and Hope Lane**  
**North/Bugsby's Way ARCADY**  
**Results**

<h1>Junctions 9</h1>
<h2>ARCADY 9 - Roundabout Module</h2>
Version: 9.0.0.4211 [] © Copyright TRL Limited, 2017
For sales and distribution information, program advice and maintenance, contact TRL: Tel: +44 (0)1344 770758 email: software@trl.co.uk Web: http://www.trlsoftware.co.uk
The users of this computer program for the solution of an engineering problem are in no way relieved of their responsibility for the correctness of the solution

Filename: Site 4 - Anchor and Hope Lane - Bugsy's Way.j9

Path: T:\30000\_Projects\30821 Charlton Riverside, Greenwich\Junction modelling\Site 4

Report generation date: 04/12/2017 10:11:44

- »2016 Baseline, AM
- »2016 Baseline, PM
- »Baseline Plus Proposed Development, AM
- »Baseline Plus Proposed Development, PM
- »Baseline Plus Other Cumulative Developments, AM
- »Baseline Plus Other Cumulative Developments, PM
- »Cumulative Development Scenario, AM
- »Cumulative Development Scenario, PM

### Summary of junction performance

	AM				PM			
	Queue (Veh)	Delay (s)	RFC	LOS	Queue (Veh)	Delay (s)	RFC	LOS
<b>2016 Baseline</b>								
1 - Anchor and Hope Lane (N)	0.1	3.30	0.08	A	0.2	4.10	0.20	A
2 - Anchor and Hope Lane (S)	1.0	3.36	0.51	A	1.0	3.15	0.49	A
3 - Bugsby's Way	0.5	3.49	0.34	A	1.2	4.23	0.54	A
<b>Baseline Plus Proposed Development</b>								
1 - Anchor and Hope Lane (N)	0.2	3.23	0.15	A	0.2	4.06	0.19	A
2 - Anchor and Hope Lane (S)	1.1	3.48	0.51	A	1.0	3.25	0.51	A
3 - Bugsby's Way	0.5	3.46	0.34	A	1.3	4.46	0.56	A
<b>Baseline Plus Other Cumulative Developments</b>								
1 - Anchor and Hope Lane (N)	0.1	3.41	0.08	A	0.3	4.33	0.21	A
2 - Anchor and Hope Lane (S)	1.1	3.52	0.53	A	1.1	3.40	0.53	A
3 - Bugsby's Way	0.6	3.61	0.37	A	1.4	4.61	0.58	A
<b>Cumulative Development Scenario</b>								
1 - Anchor and Hope Lane (N)	0.2	3.34	0.16	A	0.3	4.29	0.20	A
2 - Anchor and Hope Lane (S)	1.2	3.65	0.54	A	1.2	3.52	0.55	A
3 - Bugsby's Way	0.6	3.58	0.37	A	1.5	4.88	0.60	A

Values shown are the highest values encountered over all time segments. Delay is the maximum value of average delay per arriving vehicle.

## File summary

### File Description

<b>Title</b>	(untitled)
<b>Location</b>	
<b>Site number</b>	
<b>Date</b>	30/08/2016
<b>Version</b>	
<b>Status</b>	(new file)
<b>Identifier</b>	
<b>Client</b>	
<b>Jobnumber</b>	
<b>Enumerator</b>	TPP111"techuser
<b>Description</b>	

## Units

Distance units	Speed units	Traffic units input	Traffic units results	Flow units	Average delay units	Total delay units	Rate of delay units
m	kph	Veh	Veh	perHour	s	-Min	perMin

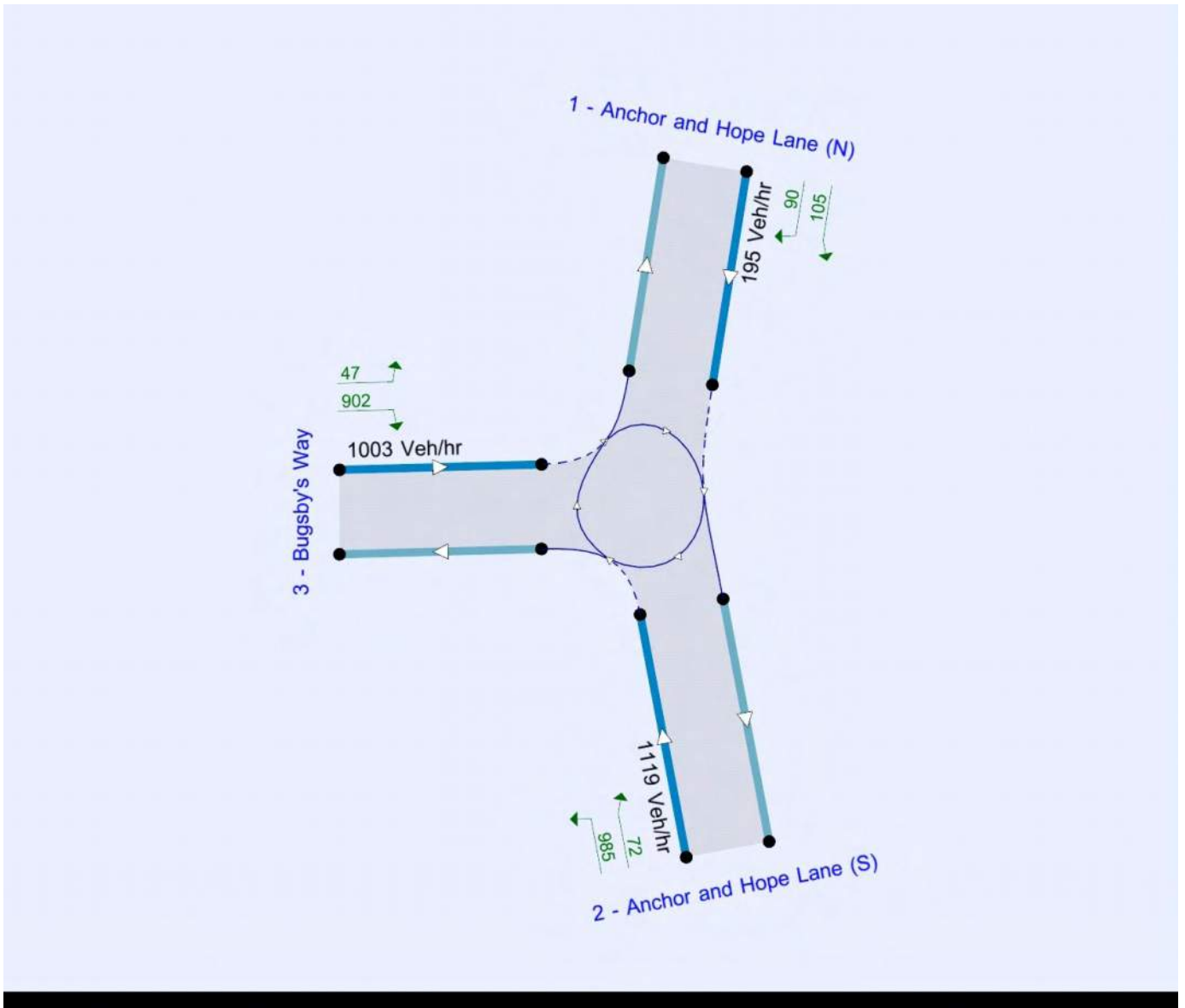

The junction diagram reflects the last run of Junctions.

### Analysis Options

Calculate Queue Percentiles	Calculate residual capacity	RFC Threshold	Average Delay threshold (s)	Queue threshold (PCU)
		0.85	36.00	20.00

## Demand Set Summary

Scenario name	Time Period name	Traffic profile type	Model start time (HH:mm)	Model finish time (HH:mm)	Time segment length (min)
2016 Baseline	AM	ONE HOUR	08:00	09:30	15
2016 Baseline	PM	ONE HOUR	17:00	18:30	15
Baseline Plus Proposed Development	AM	ONE HOUR	08:00	09:30	15
Baseline Plus Proposed Development	PM	ONE HOUR	17:00	18:30	15
Baseline Plus Other Cumulative Developments	AM	ONE HOUR	08:00	09:30	15
Baseline Plus Other Cumulative Developments	PM	ONE HOUR	17:00	18:30	15
Cumulative Development Scenario	AM	ONE HOUR	08:00	09:30	15
Cumulative Development Scenario	PM	ONE HOUR	17:00	18:30	15

# 2016 Baseline, AM

## Data Errors and Warnings

No errors or warnings

## Analysis Set Details

ID	Network flow scaling factor (%)
A1	100.000

# Junction Network

## Junctions

Junction	Name	Junction Type	Junction Delay (s)	Junction LOS
1 - untitled	untitled	Standard Roundabout	3.40	A

## Junction Network Options

Driving side	Lighting
Left	Normal/unknown

# Arms

## Arms

Arm	Name	Description
1	Anchor and Hope Lane (N)	
2	Anchor and Hope Lane (S)	
3	Bugsby's Way	

## Capacity Options

Arm	Minimum capacity (PCU/hr)	Maximum capacity (PCU/hr)
1 - Anchor and Hope Lane (N)	0.00	99999.00
2 - Anchor and Hope Lane (S)	0.00	99999.00
3 - Bugsby's Way	0.00	99999.00

## Roundabout Geometry

Arm	V - Approach road half-width (m)	E - Entry width (m)	I' - Effective flare length (m)	R - Entry radius (m)	D - Inscribed circle diameter (m)	PHI - Conflict (entry) angle (deg)	Exit only
1 - Anchor and Hope Lane (N)	4.50	7.10	22.9	18.0	40.0	42.0	
2 - Anchor and Hope Lane (S)	7.40	8.90	17.1	29.0	40.0	48.0	
3 - Bugsby's Way	5.00	8.30	8.8	42.0	40.0	24.0	

## Slope / Intercept / Capacity

### Roundabout Slope and Intercept used in model

Arm	Final slope	Final intercept (PCU/hr)
1 - Anchor and Hope Lane (N)	0.658	1849.969
2 - Anchor and Hope Lane (S)	0.782	2474.283
3 - Bugsby's Way	0.728	2060.952

The slope and intercept shown above include any corrections and adjustments.

## Traffic Demand

### Demand Set Details

ID	Scenario name	Time Period name	Traffic profile type	Model start time (HH:mm)	Model finish time (HH:mm)	Time segment length (min)
D1	2016 Baseline	AM	ONE HOUR	08:00	09:30	15

Vehicle mix varies over turn	Vehicle mix varies over entry	Vehicle mix source	PCU Factor for a HV (PCU)
✓	✓	HV Percentages	2.00

### Demand overview (Traffic)

Arm	Linked arm	Use O-D data	Average Demand (Veh/hr)	Scaling Factor (%)
1 - Anchor and Hope Lane (N)		✓	84.00	100.000
2 - Anchor and Hope Lane (S)		✓	998.00	100.000
3 - Bugsby's Way		✓	482.00	100.000

## Origin-Destination Data

### Demand (Veh/hr)

		To		
		1 - Anchor and Hope Lane (N)	2 - Anchor and Hope Lane (S)	3 - Bugsby's Way
From	1 - Anchor and Hope Lane (N)	0.000	25.000	59.000
	2 - Anchor and Hope Lane (S)	101.000	82.000	815.000
	3 - Bugsby's Way	73.000	348.000	61.000

## Vehicle Mix

### Heavy Vehicle proportion

		To		
		1 - Anchor and Hope Lane (N)	2 - Anchor and Hope Lane (S)	3 - Bugsby's Way
From	1 - Anchor and Hope Lane (N)	0	16	22
	2 - Anchor and Hope Lane (S)	6	1	8
	3 - Bugsby's Way	10	17	66

# Results

## Results Summary for whole modelled period

Arm	Max RFC	Max delay (s)	Max Queue (Veh)	Max LOS
1 - Anchor and Hope Lane (N)	0.08	3.30	0.1	A
2 - Anchor and Hope Lane (S)	0.51	3.36	1.0	A
3 - Bugsby's Way	0.34	3.49	0.5	A

## Main Results for each time segment

### Main results: (08:00-08:15)

Arm	Total Demand (Veh/hr)	Circulating flow (Veh/hr)	Capacity (Veh/hr)	RFC	Throughput (Veh/hr)	End queue (Veh)	Delay (s)	LOS
1 - Anchor and Hope Lane (N)	63.24	368.49	1296.17	0.049	63.04	0.1	2.919	A
2 - Anchor and Hope Lane (S)	751.35	90.05	2212.79	0.340	749.30	0.5	2.457	A
3 - Bugsby's Way	362.88	137.40	1602.38	0.226	361.71	0.3	2.899	A

### Main results: (08:15-08:30)

Arm	Total Demand (Veh/hr)	Circulating flow (Veh/hr)	Capacity (Veh/hr)	RFC	Throughput (Veh/hr)	End queue (Veh)	Delay (s)	LOS
1 - Anchor and Hope Lane (N)	75.51	441.06	1248.36	0.060	75.46	0.1	3.068	A
2 - Anchor and Hope Lane (S)	897.19	107.80	2194.10	0.409	896.48	0.7	2.773	A
3 - Bugsby's Way	433.31	164.38	1585.69	0.273	432.98	0.4	3.123	A

### Main results: (08:30-08:45)

Arm	Total Demand (Veh/hr)	Circulating flow (Veh/hr)	Capacity (Veh/hr)	RFC	Throughput (Veh/hr)	End queue (Veh)	Delay (s)	LOS
1 - Anchor and Hope Lane (N)	92.49	540.03	1183.17	0.078	92.40	0.1	3.299	A
2 - Anchor and Hope Lane (S)	1098.82	132.00	2168.61	0.507	1097.50	1.0	3.356	A
3 - Bugsby's Way	530.69	201.24	1562.89	0.340	530.14	0.5	3.484	A

### Main results: (08:45-09:00)

Arm	Total Demand (Veh/hr)	Circulating flow (Veh/hr)	Capacity (Veh/hr)	RFC	Throughput (Veh/hr)	End queue (Veh)	Delay (s)	LOS
1 - Anchor and Hope Lane (N)	92.49	540.60	1182.80	0.078	92.49	0.1	3.301	A
2 - Anchor and Hope Lane (S)	1098.82	132.12	2168.48	0.507	1098.81	1.0	3.364	A
3 - Bugsby's Way	530.69	201.48	1562.75	0.340	530.69	0.5	3.487	A

**Main results: (09:00-09:15)**

Arm	Total Demand (Veh/hr)	Circulating flow (Veh/hr)	Capacity (Veh/hr)	RFC	Throughput (Veh/hr)	End queue (Veh)	Delay (s)	LOS
1 - Anchor and Hope Lane (N)	75.51	441.96	1247.77	0.061	75.59	0.1	3.070	A
2 - Anchor and Hope Lane (S)	897.19	108.00	2193.88	0.409	898.50	0.7	2.783	A
3 - Bugsby's Way	433.31	164.75	1585.46	0.273	433.85	0.4	3.129	A

**Main results: (09:15-09:30)**

Arm	Total Demand (Veh/hr)	Circulating flow (Veh/hr)	Capacity (Veh/hr)	RFC	Throughput (Veh/hr)	End queue (Veh)	Delay (s)	LOS
1 - Anchor and Hope Lane (N)	63.24	370.00	1295.18	0.049	63.29	0.1	2.924	A
2 - Anchor and Hope Lane (S)	751.35	90.42	2212.40	0.340	752.07	0.5	2.467	A
3 - Bugsby's Way	362.88	137.90	1602.07	0.227	363.21	0.3	2.908	A

# 2016 Baseline, PM

## Data Errors and Warnings

*No errors or warnings*

## Analysis Set Details

ID	Network flow scaling factor (%)
A1	100.000

# Junction Network

## Junctions

Junction	Name	Junction Type	Junction Delay (s)	Junction LOS
1 - untitled	untitled	Standard Roundabout	3.71	A

## Junction Network Options

*[same as above]*

# Arms

## Arms

*[same as above]*

## Capacity Options

*[same as above]*

## Roundabout Geometry

*[same as above]*

## Slope / Intercept / Capacity

*[same as above]*

# Traffic Demand

## Demand Set Details

ID	Scenario name	Time Period name	Traffic profile type	Model start time (HH:mm)	Model finish time (HH:mm)	Time segment length (min)
D2	2016 Baseline	PM	ONE HOUR	17:00	18:30	15

Vehicle mix varies over turn	Vehicle mix varies over entry	Vehicle mix source	PCU Factor for a HV (PCU)
✓	✓	HV Percentages	2.00

## Demand overview (Traffic)

Arm	Linked arm	Use O-D data	Average Demand (Veh/hr)	Scaling Factor (%)
1 - Anchor and Hope Lane (N)		✓	197.00	100.000
2 - Anchor and Hope Lane (S)		✓	1003.00	100.000
3 - Bugsby's Way		✓	920.00	100.000

## Origin-Destination Data

### Demand (Veh/hr)

		To		
		1 - Anchor and Hope Lane (N)	2 - Anchor and Hope Lane (S)	3 - Bugsby's Way
From	1 - Anchor and Hope Lane (N)	0.000	109.000	88.000
	2 - Anchor and Hope Lane (S)	35.000	62.000	906.000
	3 - Bugsby's Way	27.000	839.000	54.000

## Vehicle Mix

### Heavy Vehicle proportion

		To		
		1 - Anchor and Hope Lane (N)	2 - Anchor and Hope Lane (S)	3 - Bugsby's Way
From	1 - Anchor and Hope Lane (N)	0	3	1
	2 - Anchor and Hope Lane (S)	20	3	4
	3 - Bugsby's Way	7	6	6

## Results

### Results Summary for whole modelled period

Arm	Max RFC	Max delay (s)	Max Queue (Veh)	Max LOS
1 - Anchor and Hope Lane (N)	0.20	4.10	0.2	A
2 - Anchor and Hope Lane (S)	0.49	3.15	1.0	A
3 - Bugsby's Way	0.54	4.23	1.2	A

## Main Results for each time segment

### Main results: (17:00-17:15)

Arm	Total Demand (Veh/hr)	Circulating flow (Veh/hr)	Capacity (Veh/hr)	RFC	Throughput (Veh/hr)	End queue (Veh)	Delay (s)	LOS
1 - Anchor and Hope Lane (N)	148.31	716.62	1323.47	0.112	147.81	0.1	3.060	A
2 - Anchor and Hope Lane (S)	755.11	106.55	2285.74	0.330	753.14	0.5	2.346	A
3 - Bugsby's Way	692.63	72.84	1889.18	0.367	690.32	0.6	2.998	A

### Main results: (17:15-17:30)

Arm	Total Demand (Veh/hr)	Circulating flow (Veh/hr)	Capacity (Veh/hr)	RFC	Throughput (Veh/hr)	End queue (Veh)	Delay (s)	LOS
1 - Anchor and Hope Lane (N)	177.10	857.69	1227.34	0.144	176.93	0.2	3.426	A
2 - Anchor and Hope Lane (S)	901.67	127.53	2269.57	0.397	901.01	0.7	2.629	A
3 - Bugsby's Way	827.06	87.14	1878.47	0.440	826.24	0.8	3.417	A

### Main results: (17:30-17:45)

Arm	Total Demand (Veh/hr)	Circulating flow (Veh/hr)	Capacity (Veh/hr)	RFC	Throughput (Veh/hr)	End queue (Veh)	Delay (s)	LOS
1 - Anchor and Hope Lane (N)	216.90	1049.86	1096.39	0.198	216.59	0.2	4.091	A
2 - Anchor and Hope Lane (S)	1104.32	156.11	2247.56	0.491	1103.10	1.0	3.143	A
3 - Bugsby's Way	1012.94	106.68	1863.82	0.543	1011.35	1.2	4.215	A

### Main results: (17:45-18:00)

Arm	Total Demand (Veh/hr)	Circulating flow (Veh/hr)	Capacity (Veh/hr)	RFC	Throughput (Veh/hr)	End queue (Veh)	Delay (s)	LOS
1 - Anchor and Hope Lane (N)	216.90	1051.45	1095.31	0.198	216.90	0.2	4.098	A
2 - Anchor and Hope Lane (S)	1104.32	156.34	2247.38	0.491	1104.31	1.0	3.148	A
3 - Bugsby's Way	1012.94	106.80	1863.74	0.544	1012.92	1.2	4.231	A

### Main results: (18:00-18:15)

Arm	Total Demand (Veh/hr)	Circulating flow (Veh/hr)	Capacity (Veh/hr)	RFC	Throughput (Veh/hr)	End queue (Veh)	Delay (s)	LOS
1 - Anchor and Hope Lane (N)	177.10	860.13	1225.68	0.144	177.40	0.2	3.434	A
2 - Anchor and Hope Lane (S)	901.67	127.88	2269.30	0.397	902.87	0.7	2.638	A
3 - Bugsby's Way	827.06	87.32	1878.33	0.440	828.63	0.8	3.436	A

### Main results: (18:15-18:30)

Arm	Total Demand (Veh/hr)	Circulating flow (Veh/hr)	Capacity (Veh/hr)	RFC	Throughput (Veh/hr)	End queue (Veh)	Delay (s)	LOS
1 - Anchor and Hope Lane (N)	148.31	719.83	1321.28	0.112	148.48	0.1	3.069	A
2 - Anchor and Hope Lane (S)	755.11	107.03	2285.36	0.330	755.78	0.5	2.356	A
3 - Bugsby's Way	692.63	73.09	1888.99	0.367	693.47	0.6	3.015	A



# Baseline Plus Proposed Development, AM

## Data Errors and Warnings

*No errors or warnings*

## Analysis Set Details

ID	Network flow scaling factor (%)
A1	100.000

# Junction Network

## Junctions

Junction	Name	Junction Type	Junction Delay (s)	Junction LOS
1 - untitled	untitled	Standard Roundabout	3.45	A

## Junction Network Options

*[same as above]*

# Arms

## Arms

*[same as above]*

## Capacity Options

*[same as above]*

## Roundabout Geometry

*[same as above]*

## Slope / Intercept / Capacity

*[same as above]*

# Traffic Demand

## Demand Set Details

ID	Scenario name	Time Period name	Traffic profile type	Model start time (HH:mm)	Model finish time (HH:mm)	Time segment length (min)
D3	Baseline Plus Proposed Development	AM	ONE HOUR	08:00	09:30	15

Vehicle mix varies over turn	Vehicle mix varies over entry	Vehicle mix source	PCU Factor for a HV (PCU)
✓	✓	HV Percentages	2.00

## Demand overview (Traffic)

Arm	Linked arm	Use O-D data	Average Demand (Veh/hr)	Scaling Factor (%)
1 - Anchor and Hope Lane (N)		✓	182.00	100.000
2 - Anchor and Hope Lane (S)		✓	992.00	100.000
3 - Bugsby's Way		✓	477.00	100.000

## Origin-Destination Data

### Demand (Veh/hr)

		To		
		1 - Anchor and Hope Lane (N)	2 - Anchor and Hope Lane (S)	3 - Bugsby's Way
From	1 - Anchor and Hope Lane (N)	0.000	69.000	113.000
	2 - Anchor and Hope Lane (S)	95.000	82.000	815.000
	3 - Bugsby's Way	68.000	348.000	61.000

## Vehicle Mix

### Heavy Vehicle proportion

		To		
		1 - Anchor and Hope Lane (N)	2 - Anchor and Hope Lane (S)	3 - Bugsby's Way
From	1 - Anchor and Hope Lane (N)	0	5	10
	2 - Anchor and Hope Lane (S)	6	1	8
	3 - Bugsby's Way	10	17	66

## Results

### Results Summary for whole modelled period

Arm	Max RFC	Max delay (s)	Max Queue (Veh)	Max LOS
1 - Anchor and Hope Lane (N)	0.15	3.23	0.2	A
2 - Anchor and Hope Lane (S)	0.51	3.48	1.1	A
3 - Bugsby's Way	0.34	3.46	0.5	A

## Main Results for each time segment

### Main results: (08:00-08:15)

Arm	Total Demand (Veh/hr)	Circulating flow (Veh/hr)	Capacity (Veh/hr)	RFC	Throughput (Veh/hr)	End queue (Veh)	Delay (s)	LOS
1 - Anchor and Hope Lane (N)	137.02	368.49	1441.37	0.095	136.60	0.1	2.759	A
2 - Anchor and Hope Lane (S)	746.83	130.59	2183.97	0.342	744.76	0.5	2.498	A
3 - Bugsby's Way	359.11	132.89	1603.56	0.224	357.96	0.3	2.887	A

### Main results: (08:15-08:30)

Arm	Total Demand (Veh/hr)	Circulating flow (Veh/hr)	Capacity (Veh/hr)	RFC	Throughput (Veh/hr)	End queue (Veh)	Delay (s)	LOS
1 - Anchor and Hope Lane (N)	163.61	441.06	1388.21	0.118	163.50	0.1	2.939	A
2 - Anchor and Hope Lane (S)	891.79	156.31	2159.65	0.413	891.06	0.7	2.836	A
3 - Bugsby's Way	428.81	158.99	1587.45	0.270	428.49	0.4	3.106	A

### Main results: (08:30-08:45)

Arm	Total Demand (Veh/hr)	Circulating flow (Veh/hr)	Capacity (Veh/hr)	RFC	Throughput (Veh/hr)	End queue (Veh)	Delay (s)	LOS
1 - Anchor and Hope Lane (N)	200.39	540.03	1315.71	0.152	200.20	0.2	3.227	A
2 - Anchor and Hope Lane (S)	1092.21	191.40	2126.47	0.514	1090.82	1.0	3.471	A
3 - Bugsby's Way	525.19	194.63	1565.44	0.335	524.65	0.5	3.457	A

### Main results: (08:45-09:00)

Arm	Total Demand (Veh/hr)	Circulating flow (Veh/hr)	Capacity (Veh/hr)	RFC	Throughput (Veh/hr)	End queue (Veh)	Delay (s)	LOS
1 - Anchor and Hope Lane (N)	200.39	540.60	1315.30	0.152	200.38	0.2	3.228	A
2 - Anchor and Hope Lane (S)	1092.21	191.58	2126.30	0.514	1092.19	1.1	3.480	A
3 - Bugsby's Way	525.19	194.88	1565.29	0.336	525.18	0.5	3.460	A

### Main results: (09:00-09:15)

Arm	Total Demand (Veh/hr)	Circulating flow (Veh/hr)	Capacity (Veh/hr)	RFC	Throughput (Veh/hr)	End queue (Veh)	Delay (s)	LOS
1 - Anchor and Hope Lane (N)	163.61	441.97	1387.55	0.118	163.80	0.1	2.941	A
2 - Anchor and Hope Lane (S)	891.79	156.60	2159.37	0.413	893.17	0.7	2.847	A
3 - Bugsby's Way	428.81	159.36	1587.22	0.270	429.34	0.4	3.109	A

### Main results: (09:15-09:30)

Arm	Total Demand (Veh/hr)	Circulating flow (Veh/hr)	Capacity (Veh/hr)	RFC	Throughput (Veh/hr)	End queue (Veh)	Delay (s)	LOS
1 - Anchor and Hope Lane (N)	137.02	369.99	1440.27	0.095	137.13	0.1	2.764	A
2 - Anchor and Hope Lane (S)	746.83	131.11	2183.48	0.342	747.57	0.5	2.509	A
3 - Bugsby's Way	359.11	133.39	1603.25	0.224	359.44	0.3	2.896	A



# Baseline Plus Proposed Development, PM

## Data Errors and Warnings

*No errors or warnings*

## Analysis Set Details

ID	Network flow scaling factor (%)
A1	100.000

# Junction Network

## Junctions

Junction	Name	Junction Type	Junction Delay (s)	Junction LOS
1 - untitled	untitled	Standard Roundabout	3.85	A

## Junction Network Options

*[same as above]*

# Arms

## Arms

*[same as above]*

## Capacity Options

*[same as above]*

## Roundabout Geometry

*[same as above]*

## Slope / Intercept / Capacity

*[same as above]*

# Traffic Demand

## Demand Set Details

ID	Scenario name	Time Period name	Traffic profile type	Model start time (HH:mm)	Model finish time (HH:mm)	Time segment length (min)
D4	Baseline Plus Proposed Development	PM	ONE HOUR	17:00	18:30	15

Vehicle mix varies over turn	Vehicle mix varies over entry	Vehicle mix source	PCU Factor for a HV (PCU)
✓	✓	HV Percentages	2.00

## Demand overview (Traffic)

Arm	Linked arm	Use O-D data	Average Demand (Veh/hr)	Scaling Factor (%)
1 - Anchor and Hope Lane (N)		✓	195.00	100.000
2 - Anchor and Hope Lane (S)		✓	1040.00	100.000
3 - Bugsby's Way		✓	940.00	100.000

## Origin-Destination Data

### Demand (Veh/hr)

		To		
		1 - Anchor and Hope Lane (N)	2 - Anchor and Hope Lane (S)	3 - Bugsby's Way
From	1 - Anchor and Hope Lane (N)	0.000	105.000	90.000
	2 - Anchor and Hope Lane (S)	72.000	62.000	906.000
	3 - Bugsby's Way	47.000	839.000	54.000

## Vehicle Mix

### Heavy Vehicle proportion

		To		
		1 - Anchor and Hope Lane (N)	2 - Anchor and Hope Lane (S)	3 - Bugsby's Way
From	1 - Anchor and Hope Lane (N)	0	2	1
	2 - Anchor and Hope Lane (S)	7	3	4
	3 - Bugsby's Way	1	6	6

## Results

### Results Summary for whole modelled period

Arm	Max RFC	Max delay (s)	Max Queue (Veh)	Max LOS
1 - Anchor and Hope Lane (N)	0.19	4.06	0.2	A
2 - Anchor and Hope Lane (S)	0.51	3.25	1.0	A
3 - Bugsby's Way	0.56	4.46	1.3	A

## Main Results for each time segment

### Main results: (17:00-17:15)

Arm	Total Demand (Veh/hr)	Circulating flow (Veh/hr)	Capacity (Veh/hr)	RFC	Throughput (Veh/hr)	End queue (Veh)	Delay (s)	LOS
1 - Anchor and Hope Lane (N)	146.81	716.56	1330.93	0.110	146.31	0.1	3.037	A
2 - Anchor and Hope Lane (S)	782.97	108.04	2292.26	0.342	780.90	0.5	2.379	A
3 - Bugsby's Way	707.68	100.62	1876.06	0.377	705.27	0.6	3.068	A

### Main results: (17:15-17:30)

Arm	Total Demand (Veh/hr)	Circulating flow (Veh/hr)	Capacity (Veh/hr)	RFC	Throughput (Veh/hr)	End queue (Veh)	Delay (s)	LOS
1 - Anchor and Hope Lane (N)	175.30	857.64	1234.26	0.142	175.14	0.2	3.398	A
2 - Anchor and Hope Lane (S)	934.94	129.33	2275.82	0.411	934.23	0.7	2.682	A
3 - Bugsby's Way	845.04	120.37	1861.76	0.454	844.15	0.8	3.534	A

### Main results: (17:30-17:45)

Arm	Total Demand (Veh/hr)	Circulating flow (Veh/hr)	Capacity (Veh/hr)	RFC	Throughput (Veh/hr)	End queue (Veh)	Delay (s)	LOS
1 - Anchor and Hope Lane (N)	214.70	1049.71	1102.64	0.195	214.40	0.2	4.052	A
2 - Anchor and Hope Lane (S)	1145.06	158.31	2253.43	0.508	1143.73	1.0	3.239	A
3 - Bugsby's Way	1034.96	147.37	1842.22	0.562	1033.19	1.3	4.440	A

### Main results: (17:45-18:00)

Arm	Total Demand (Veh/hr)	Circulating flow (Veh/hr)	Capacity (Veh/hr)	RFC	Throughput (Veh/hr)	End queue (Veh)	Delay (s)	LOS
1 - Anchor and Hope Lane (N)	214.70	1051.45	1101.45	0.195	214.70	0.2	4.059	A
2 - Anchor and Hope Lane (S)	1145.06	158.54	2253.24	0.508	1145.05	1.0	3.247	A
3 - Bugsby's Way	1034.96	147.54	1842.09	0.562	1034.93	1.3	4.459	A

### Main results: (18:00-18:15)

Arm	Total Demand (Veh/hr)	Circulating flow (Veh/hr)	Capacity (Veh/hr)	RFC	Throughput (Veh/hr)	End queue (Veh)	Delay (s)	LOS
1 - Anchor and Hope Lane (N)	175.30	860.27	1232.45	0.142	175.60	0.2	3.409	A
2 - Anchor and Hope Lane (S)	934.94	129.69	2275.53	0.411	936.25	0.7	2.690	A
3 - Bugsby's Way	845.04	120.63	1861.57	0.454	846.79	0.8	3.552	A

### Main results: (18:15-18:30)

Arm	Total Demand (Veh/hr)	Circulating flow (Veh/hr)	Capacity (Veh/hr)	RFC	Throughput (Veh/hr)	End queue (Veh)	Delay (s)	LOS
1 - Anchor and Hope Lane (N)	146.81	719.89	1328.65	0.110	146.97	0.1	3.046	A
2 - Anchor and Hope Lane (S)	782.97	108.54	2291.88	0.342	783.69	0.5	2.389	A
3 - Bugsby's Way	707.68	100.98	1875.80	0.377	708.59	0.6	3.088	A



# Baseline Plus Other Cumulative Developments, AM

## Data Errors and Warnings

*No errors or warnings*

## Analysis Set Details

ID	Network flow scaling factor (%)
A1	100.000

# Junction Network

## Junctions

Junction	Name	Junction Type	Junction Delay (s)	Junction LOS
1 - untitled	untitled	Standard Roundabout	3.55	A

## Junction Network Options

*[same as above]*

# Arms

## Arms

*[same as above]*

## Capacity Options

*[same as above]*

## Roundabout Geometry

*[same as above]*

## Slope / Intercept / Capacity

*[same as above]*

# Traffic Demand

## Demand Set Details

ID	Scenario name	Time Period name	Traffic profile type	Model start time (HH:mm)	Model finish time (HH:mm)	Time segment length (min)
D5	Baseline Plus Other Cumulative Developments	AM	ONE HOUR	08:00	09:30	15

Vehicle mix varies over turn	Vehicle mix varies over entry	Vehicle mix source	PCU Factor for a HV (PCU)
✓	✓	HV Percentages	2.00

## Demand overview (Traffic)

Arm	Linked arm	Use O-D data	Average Demand (Veh/hr)	Scaling Factor (%)
1 - Anchor and Hope Lane (N)		✓	84.00	100.000
2 - Anchor and Hope Lane (S)		✓	1041.00	100.000
3 - Bugsby's Way		✓	538.00	100.000

## Origin-Destination Data

### Demand (Veh/hr)

		To		
		1 - Anchor and Hope Lane (N)	2 - Anchor and Hope Lane (S)	3 - Bugsby's Way
From	1 - Anchor and Hope Lane (N)	0.000	25.000	59.000
	2 - Anchor and Hope Lane (S)	101.000	82.000	858.000
	3 - Bugsby's Way	73.000	404.000	61.000

## Vehicle Mix

### Heavy Vehicle proportion

		To		
		1 - Anchor and Hope Lane (N)	2 - Anchor and Hope Lane (S)	3 - Bugsby's Way
From	1 - Anchor and Hope Lane (N)	0	16	22
	2 - Anchor and Hope Lane (S)	6	1	8
	3 - Bugsby's Way	10	15	66

## Results

### Results Summary for whole modelled period

Arm	Max RFC	Max delay (s)	Max Queue (Veh)	Max LOS
1 - Anchor and Hope Lane (N)	0.08	3.41	0.1	A
2 - Anchor and Hope Lane (S)	0.53	3.52	1.1	A
3 - Bugsby's Way	0.37	3.61	0.6	A

## Main Results for each time segment

### Main results: (08:00-08:15)

Arm	Total Demand (Veh/hr)	Circulating flow (Veh/hr)	Capacity (Veh/hr)	RFC	Throughput (Veh/hr)	End queue (Veh)	Delay (s)	LOS
1 - Anchor and Hope Lane (N)	63.24	410.50	1272.60	0.050	63.03	0.1	2.976	A
2 - Anchor and Hope Lane (S)	783.72	90.05	2212.11	0.354	781.53	0.5	2.513	A
3 - Bugsby's Way	405.03	137.39	1629.56	0.249	403.72	0.3	2.934	A

### Main results: (08:15-08:30)

Arm	Total Demand (Veh/hr)	Circulating flow (Veh/hr)	Capacity (Veh/hr)	RFC	Throughput (Veh/hr)	End queue (Veh)	Delay (s)	LOS
1 - Anchor and Hope Lane (N)	75.51	491.34	1220.15	0.062	75.46	0.1	3.144	A
2 - Anchor and Hope Lane (S)	935.83	107.80	2193.43	0.427	935.06	0.7	2.859	A
3 - Bugsby's Way	483.65	164.38	1612.59	0.300	483.26	0.4	3.188	A

### Main results: (08:30-08:45)

Arm	Total Demand (Veh/hr)	Circulating flow (Veh/hr)	Capacity (Veh/hr)	RFC	Throughput (Veh/hr)	End queue (Veh)	Delay (s)	LOS
1 - Anchor and Hope Lane (N)	92.49	601.57	1148.64	0.081	92.40	0.1	3.407	A
2 - Anchor and Hope Lane (S)	1146.16	131.99	2167.96	0.529	1144.67	1.1	3.514	A
3 - Bugsby's Way	592.35	201.22	1589.41	0.373	591.69	0.6	3.606	A

### Main results: (08:45-09:00)

Arm	Total Demand (Veh/hr)	Circulating flow (Veh/hr)	Capacity (Veh/hr)	RFC	Throughput (Veh/hr)	End queue (Veh)	Delay (s)	LOS
1 - Anchor and Hope Lane (N)	92.49	602.25	1148.21	0.081	92.49	0.1	3.409	A
2 - Anchor and Hope Lane (S)	1146.16	132.12	2167.81	0.529	1146.14	1.1	3.522	A
3 - Bugsby's Way	592.35	201.48	1589.25	0.373	592.34	0.6	3.610	A

### Main results: (09:00-09:15)

Arm	Total Demand (Veh/hr)	Circulating flow (Veh/hr)	Capacity (Veh/hr)	RFC	Throughput (Veh/hr)	End queue (Veh)	Delay (s)	LOS
1 - Anchor and Hope Lane (N)	75.51	492.42	1219.46	0.062	75.60	0.1	3.149	A
2 - Anchor and Hope Lane (S)	935.83	108.01	2193.20	0.427	937.31	0.7	2.871	A
3 - Bugsby's Way	483.65	164.77	1612.34	0.300	484.30	0.4	3.192	A

### Main results: (09:15-09:30)

Arm	Total Demand (Veh/hr)	Circulating flow (Veh/hr)	Capacity (Veh/hr)	RFC	Throughput (Veh/hr)	End queue (Veh)	Delay (s)	LOS
1 - Anchor and Hope Lane (N)	63.24	412.21	1271.49	0.050	63.29	0.1	2.979	A
2 - Anchor and Hope Lane (S)	783.72	90.43	2211.71	0.354	784.50	0.6	2.525	A
3 - Bugsby's Way	405.03	137.91	1629.23	0.249	405.43	0.3	2.944	A



# Baseline Plus Other Cumulative Developments, PM

## Data Errors and Warnings

*No errors or warnings*

## Analysis Set Details

ID	Network flow scaling factor (%)
A1	100.000

# Junction Network

## Junctions

Junction	Name	Junction Type	Junction Delay (s)	Junction LOS
1 - untitled	untitled	Standard Roundabout	4.01	A

## Junction Network Options

*[same as above]*

# Arms

## Arms

*[same as above]*

## Capacity Options

*[same as above]*

## Roundabout Geometry

*[same as above]*

## Slope / Intercept / Capacity

*[same as above]*

# Traffic Demand

## Demand Set Details

ID	Scenario name	Time Period name	Traffic profile type	Model start time (HH:mm)	Model finish time (HH:mm)	Time segment length (min)
D6	Baseline Plus Other Cumulative Developments	PM	ONE HOUR	17:00	18:30	15

Vehicle mix varies over turn	Vehicle mix varies over entry	Vehicle mix source	PCU Factor for a HV (PCU)
✓	✓	HV Percentages	2.00

## Demand overview (Traffic)

Arm	Linked arm	Use O-D data	Average Demand (Veh/hr)	Scaling Factor (%)
1 - Anchor and Hope Lane (N)		✓	197.00	100.000
2 - Anchor and Hope Lane (S)		✓	1082.00	100.000
3 - Bugsby's Way		✓	983.00	100.000

## Origin-Destination Data

### Demand (Veh/hr)

From	To			
		1 - Anchor and Hope Lane (N)	2 - Anchor and Hope Lane (S)	3 - Bugsby's Way
1 - Anchor and Hope Lane (N)		0.000	109.000	88.000
2 - Anchor and Hope Lane (S)		35.000	62.000	985.000
3 - Bugsby's Way		27.000	902.000	54.000

## Vehicle Mix

### Heavy Vehicle proportion

From	To			
		1 - Anchor and Hope Lane (N)	2 - Anchor and Hope Lane (S)	3 - Bugsby's Way
1 - Anchor and Hope Lane (N)		0	3	1
2 - Anchor and Hope Lane (S)		20	3	4
3 - Bugsby's Way		7	6	6

## Results

### Results Summary for whole modelled period

Arm	Max RFC	Max delay (s)	Max Queue (Veh)	Max LOS
1 - Anchor and Hope Lane (N)	0.21	4.33	0.3	A
2 - Anchor and Hope Lane (S)	0.53	3.40	1.1	A
3 - Bugsby's Way	0.58	4.61	1.4	A

## Main Results for each time segment

### Main results: (17:00-17:15)

Arm	Total Demand (Veh/hr)	Circulating flow (Veh/hr)	Capacity (Veh/hr)	RFC	Throughput (Veh/hr)	End queue (Veh)	Delay (s)	LOS
1 - Anchor and Hope Lane (N)	148.31	763.79	1291.27	0.115	147.79	0.1	3.146	A
2 - Anchor and Hope Lane (S)	814.59	106.53	2286.56	0.356	812.38	0.6	2.439	A
3 - Bugsby's Way	740.06	72.83	1889.22	0.392	737.50	0.6	3.119	A

### Main results: (17:15-17:30)

Arm	Total Demand (Veh/hr)	Circulating flow (Veh/hr)	Capacity (Veh/hr)	RFC	Throughput (Veh/hr)	End queue (Veh)	Delay (s)	LOS
1 - Anchor and Hope Lane (N)	177.10	914.18	1188.78	0.149	176.92	0.2	3.557	A
2 - Anchor and Hope Lane (S)	972.70	127.52	2270.38	0.428	971.92	0.7	2.771	A
3 - Bugsby's Way	883.70	87.13	1878.51	0.470	882.74	0.9	3.612	A

### Main results: (17:30-17:45)

Arm	Total Demand (Veh/hr)	Circulating flow (Veh/hr)	Capacity (Veh/hr)	RFC	Throughput (Veh/hr)	End queue (Veh)	Delay (s)	LOS
1 - Anchor and Hope Lane (N)	216.90	1118.86	1049.29	0.207	216.56	0.3	4.321	A
2 - Anchor and Hope Lane (S)	1191.31	156.09	2248.37	0.530	1189.82	1.1	3.396	A
3 - Bugsby's Way	1082.31	106.67	1863.87	0.581	1080.36	1.4	4.584	A

### Main results: (17:45-18:00)

Arm	Total Demand (Veh/hr)	Circulating flow (Veh/hr)	Capacity (Veh/hr)	RFC	Throughput (Veh/hr)	End queue (Veh)	Delay (s)	LOS
1 - Anchor and Hope Lane (N)	216.90	1120.81	1047.96	0.207	216.90	0.3	4.331	A
2 - Anchor and Hope Lane (S)	1191.31	156.34	2248.18	0.530	1191.29	1.1	3.405	A
3 - Bugsby's Way	1082.31	106.80	1863.77	0.581	1082.28	1.4	4.606	A

### Main results: (18:00-18:15)

Arm	Total Demand (Veh/hr)	Circulating flow (Veh/hr)	Capacity (Veh/hr)	RFC	Throughput (Veh/hr)	End queue (Veh)	Delay (s)	LOS
1 - Anchor and Hope Lane (N)	177.10	917.12	1186.77	0.149	177.43	0.2	3.569	A
2 - Anchor and Hope Lane (S)	972.70	127.91	2270.08	0.428	974.17	0.8	2.780	A
3 - Bugsby's Way	883.70	87.33	1878.36	0.470	885.63	0.9	3.635	A

### Main results: (18:15-18:30)

Arm	Total Demand (Veh/hr)	Circulating flow (Veh/hr)	Capacity (Veh/hr)	RFC	Throughput (Veh/hr)	End queue (Veh)	Delay (s)	LOS
1 - Anchor and Hope Lane (N)	148.31	767.41	1288.80	0.115	148.49	0.1	3.159	A
2 - Anchor and Hope Lane (S)	814.59	107.04	2286.16	0.356	815.38	0.6	2.450	A
3 - Bugsby's Way	740.06	73.10	1889.02	0.392	741.05	0.6	3.137	A



# Cumulative Development Scenario, AM

## Data Errors and Warnings

*No errors or warnings*

## Analysis Set Details

ID	Network flow scaling factor (%)
A1	100.000

# Junction Network

## Junctions

Junction	Name	Junction Type	Junction Delay (s)	Junction LOS
1 - untitled	untitled	Standard Roundabout	3.60	A

## Junction Network Options

*[same as above]*

# Arms

## Arms

*[same as above]*

## Capacity Options

*[same as above]*

## Roundabout Geometry

*[same as above]*

## Slope / Intercept / Capacity

*[same as above]*

# Traffic Demand

## Demand Set Details

ID	Scenario name	Time Period name	Traffic profile type	Model start time (HH:mm)	Model finish time (HH:mm)	Time segment length (min)
D7	Cumulative Development Scenario	AM	ONE HOUR	08:00	09:30	15

Vehicle mix varies over turn	Vehicle mix varies over entry	Vehicle mix source	PCU Factor for a HV (PCU)
✓	✓	HV Percentages	2.00

## Demand overview (Traffic)

Arm	Linked arm	Use O-D data	Average Demand (Veh/hr)	Scaling Factor (%)
1 - Anchor and Hope Lane (N)		✓	182.00	100.000
2 - Anchor and Hope Lane (S)		✓	1035.00	100.000
3 - Bugsby's Way		✓	533.00	100.000

## Origin-Destination Data

### Demand (Veh/hr)

From	To			
		1 - Anchor and Hope Lane (N)	2 - Anchor and Hope Lane (S)	3 - Bugsby's Way
1 - Anchor and Hope Lane (N)		0.000	69.000	113.000
2 - Anchor and Hope Lane (S)		95.000	82.000	858.000
3 - Bugsby's Way		68.000	404.000	61.000

## Vehicle Mix

### Heavy Vehicle proportion

From	To			
		1 - Anchor and Hope Lane (N)	2 - Anchor and Hope Lane (S)	3 - Bugsby's Way
1 - Anchor and Hope Lane (N)		0	5	10
2 - Anchor and Hope Lane (S)		6	1	8
3 - Bugsby's Way		10	15	66

## Results

### Results Summary for whole modelled period

Arm	Max RFC	Max delay (s)	Max Queue (Veh)	Max LOS
1 - Anchor and Hope Lane (N)	0.16	3.34	0.2	A
2 - Anchor and Hope Lane (S)	0.54	3.65	1.2	A
3 - Bugsby's Way	0.37	3.58	0.6	A

## Main Results for each time segment

### Main results: (08:00-08:15)

Arm	Total Demand (Veh/hr)	Circulating flow (Veh/hr)	Capacity (Veh/hr)	RFC	Throughput (Veh/hr)	End queue (Veh)	Delay (s)	LOS
1 - Anchor and Hope Lane (N)	137.02	410.50	1415.16	0.097	136.59	0.1	2.816	A
2 - Anchor and Hope Lane (S)	779.20	130.58	2183.32	0.357	776.99	0.6	2.560	A
3 - Bugsby's Way	401.27	132.88	1631.17	0.246	399.97	0.3	2.921	A

### Main results: (08:15-08:30)

Arm	Total Demand (Veh/hr)	Circulating flow (Veh/hr)	Capacity (Veh/hr)	RFC	Throughput (Veh/hr)	End queue (Veh)	Delay (s)	LOS
1 - Anchor and Hope Lane (N)	163.61	491.35	1356.83	0.121	163.50	0.1	3.016	A
2 - Anchor and Hope Lane (S)	930.44	156.31	2159.01	0.431	929.64	0.8	2.927	A
3 - Bugsby's Way	479.16	158.98	1614.78	0.297	478.78	0.4	3.169	A

### Main results: (08:30-08:45)

Arm	Total Demand (Veh/hr)	Circulating flow (Veh/hr)	Capacity (Veh/hr)	RFC	Throughput (Veh/hr)	End queue (Veh)	Delay (s)	LOS
1 - Anchor and Hope Lane (N)	200.39	601.58	1277.31	0.157	200.19	0.2	3.342	A
2 - Anchor and Hope Lane (S)	1139.55	191.38	2125.85	0.536	1137.98	1.1	3.637	A
3 - Bugsby's Way	586.84	194.61	1592.40	0.369	586.20	0.6	3.576	A

### Main results: (08:45-09:00)

Arm	Total Demand (Veh/hr)	Circulating flow (Veh/hr)	Capacity (Veh/hr)	RFC	Throughput (Veh/hr)	End queue (Veh)	Delay (s)	LOS
1 - Anchor and Hope Lane (N)	200.39	602.25	1276.83	0.157	200.38	0.2	3.343	A
2 - Anchor and Hope Lane (S)	1139.55	191.58	2125.67	0.536	1139.53	1.2	3.649	A
3 - Bugsby's Way	586.84	194.88	1592.24	0.369	586.84	0.6	3.579	A

### Main results: (09:00-09:15)

Arm	Total Demand (Veh/hr)	Circulating flow (Veh/hr)	Capacity (Veh/hr)	RFC	Throughput (Veh/hr)	End queue (Veh)	Delay (s)	LOS
1 - Anchor and Hope Lane (N)	163.61	492.41	1356.07	0.121	163.81	0.1	3.021	A
2 - Anchor and Hope Lane (S)	930.44	156.61	2158.71	0.431	932.00	0.8	2.940	A
3 - Bugsby's Way	479.16	159.38	1614.52	0.297	479.79	0.4	3.173	A

### Main results: (09:15-09:30)

Arm	Total Demand (Veh/hr)	Circulating flow (Veh/hr)	Capacity (Veh/hr)	RFC	Throughput (Veh/hr)	End queue (Veh)	Delay (s)	LOS
1 - Anchor and Hope Lane (N)	137.02	412.21	1413.92	0.097	137.14	0.1	2.821	A
2 - Anchor and Hope Lane (S)	779.20	131.12	2182.82	0.357	780.02	0.6	2.569	A
3 - Bugsby's Way	401.27	133.39	1630.85	0.246	401.66	0.3	2.929	A



# Cumulative Development Scenario, PM

## Data Errors and Warnings

*No errors or warnings*

## Analysis Set Details

ID	Network flow scaling factor (%)
A1	100.000

# Junction Network

## Junctions

Junction	Name	Junction Type	Junction Delay (s)	Junction LOS
1 - untitled	untitled	Standard Roundabout	4.18	A

## Junction Network Options

*[same as above]*

# Arms

## Arms

*[same as above]*

## Capacity Options

*[same as above]*

## Roundabout Geometry

*[same as above]*

## Slope / Intercept / Capacity

*[same as above]*

# Traffic Demand

## Demand Set Details

ID	Scenario name	Time Period name	Traffic profile type	Model start time (HH:mm)	Model finish time (HH:mm)	Time segment length (min)
D8	Cumulative Development Scenario	PM	ONE HOUR	17:00	18:30	15

Vehicle mix varies over turn	Vehicle mix varies over entry	Vehicle mix source	PCU Factor for a HV (PCU)
✓	✓	HV Percentages	2.00

## Demand overview (Traffic)

Arm	Linked arm	Use O-D data	Average Demand (Veh/hr)	Scaling Factor (%)
1 - Anchor and Hope Lane (N)		✓	195.00	100.000
2 - Anchor and Hope Lane (S)		✓	1119.00	100.000
3 - Bugsby's Way		✓	1003.00	100.000

## Origin-Destination Data

### Demand (Veh/hr)

		To		
		1 - Anchor and Hope Lane (N)	2 - Anchor and Hope Lane (S)	3 - Bugsby's Way
From	1 - Anchor and Hope Lane (N)	0.000	105.000	90.000
	2 - Anchor and Hope Lane (S)	72.000	62.000	985.000
	3 - Bugsby's Way	47.000	902.000	54.000

## Vehicle Mix

### Heavy Vehicle proportion

		To		
		1 - Anchor and Hope Lane (N)	2 - Anchor and Hope Lane (S)	3 - Bugsby's Way
From	1 - Anchor and Hope Lane (N)	0	2	1
	2 - Anchor and Hope Lane (S)	7	3	4
	3 - Bugsby's Way	1	6	6

## Results

### Results Summary for whole modelled period

Arm	Max RFC	Max delay (s)	Max Queue (Veh)	Max LOS
1 - Anchor and Hope Lane (N)	0.20	4.29	0.3	A
2 - Anchor and Hope Lane (S)	0.55	3.52	1.2	A
3 - Bugsby's Way	0.60	4.88	1.5	A

## Main Results for each time segment

### Main results: (17:00-17:15)

Arm	Total Demand (Veh/hr)	Circulating flow (Veh/hr)	Capacity (Veh/hr)	RFC	Throughput (Veh/hr)	End queue (Veh)	Delay (s)	LOS
1 - Anchor and Hope Lane (N)	146.81	763.72	1298.55	0.113	146.30	0.1	3.122	A
2 - Anchor and Hope Lane (S)	842.44	108.03	2292.49	0.367	840.13	0.6	2.474	A
3 - Bugsby's Way	755.11	100.61	1875.78	0.403	752.43	0.7	3.196	A

### Main results: (17:15-17:30)

Arm	Total Demand (Veh/hr)	Circulating flow (Veh/hr)	Capacity (Veh/hr)	RFC	Throughput (Veh/hr)	End queue (Veh)	Delay (s)	LOS
1 - Anchor and Hope Lane (N)	175.30	914.12	1195.48	0.147	175.13	0.2	3.527	A
2 - Anchor and Hope Lane (S)	1005.95	129.31	2276.04	0.442	1005.12	0.8	2.831	A
3 - Bugsby's Way	901.67	120.36	1861.48	0.484	900.62	0.9	3.743	A

### Main results: (17:30-17:45)

Arm	Total Demand (Veh/hr)	Circulating flow (Veh/hr)	Capacity (Veh/hr)	RFC	Throughput (Veh/hr)	End queue (Veh)	Delay (s)	LOS
1 - Anchor and Hope Lane (N)	214.70	1118.67	1055.30	0.203	214.37	0.3	4.278	A
2 - Anchor and Hope Lane (S)	1232.04	158.28	2253.67	0.547	1230.40	1.2	3.511	A
3 - Bugsby's Way	1104.32	147.34	1841.95	0.600	1102.14	1.5	4.851	A

### Main results: (17:45-18:00)

Arm	Total Demand (Veh/hr)	Circulating flow (Veh/hr)	Capacity (Veh/hr)	RFC	Throughput (Veh/hr)	End queue (Veh)	Delay (s)	LOS
1 - Anchor and Hope Lane (N)	214.70	1120.80	1053.83	0.204	214.70	0.3	4.289	A
2 - Anchor and Hope Lane (S)	1232.04	158.54	2253.46	0.547	1232.02	1.2	3.523	A
3 - Bugsby's Way	1104.32	147.53	1841.81	0.600	1104.28	1.5	4.880	A

### Main results: (18:00-18:15)

Arm	Total Demand (Veh/hr)	Circulating flow (Veh/hr)	Capacity (Veh/hr)	RFC	Throughput (Veh/hr)	End queue (Veh)	Delay (s)	LOS
1 - Anchor and Hope Lane (N)	175.30	917.31	1193.29	0.147	175.63	0.2	3.537	A
2 - Anchor and Hope Lane (S)	1005.95	129.72	2275.73	0.442	1007.57	0.8	2.843	A
3 - Bugsby's Way	901.67	120.66	1861.27	0.484	903.83	0.9	3.770	A

### Main results: (18:15-18:30)

Arm	Total Demand (Veh/hr)	Circulating flow (Veh/hr)	Capacity (Veh/hr)	RFC	Throughput (Veh/hr)	End queue (Veh)	Delay (s)	LOS
1 - Anchor and Hope Lane (N)	146.81	767.48	1295.98	0.113	146.99	0.1	3.132	A
2 - Anchor and Hope Lane (S)	842.44	108.55	2292.09	0.368	843.29	0.6	2.487	A
3 - Bugsby's Way	755.11	100.98	1875.51	0.403	756.19	0.7	3.218	A

**Appendix F**  
**Woolwich Road/Anchor and**  
**Hope Lane/Charlton Church**  
**Lane LinSig Results**

Basic Results Summary  
**Basic Results Summary**

**Project and User Details**

<b>Project:</b>	
<b>Title:</b>	
<b>Location:</b>	
<b>File name:</b>	Site 5 - Woolwich Road - Anchor & Hope Lane - Charlton Church Lane.lsg3x
<b>Author:</b>	
<b>Company:</b>	
<b>Address:</b>	
<b>Notes:</b>	
<b>Linsig Version:</b>	3, 2, 28, 0

**Scenario 1: 'Baseline AM Peak'** (FG1: 'Baseline AM Peak', Plan 1: 'Network Control Plan 1')

**Network Layout Diagram**

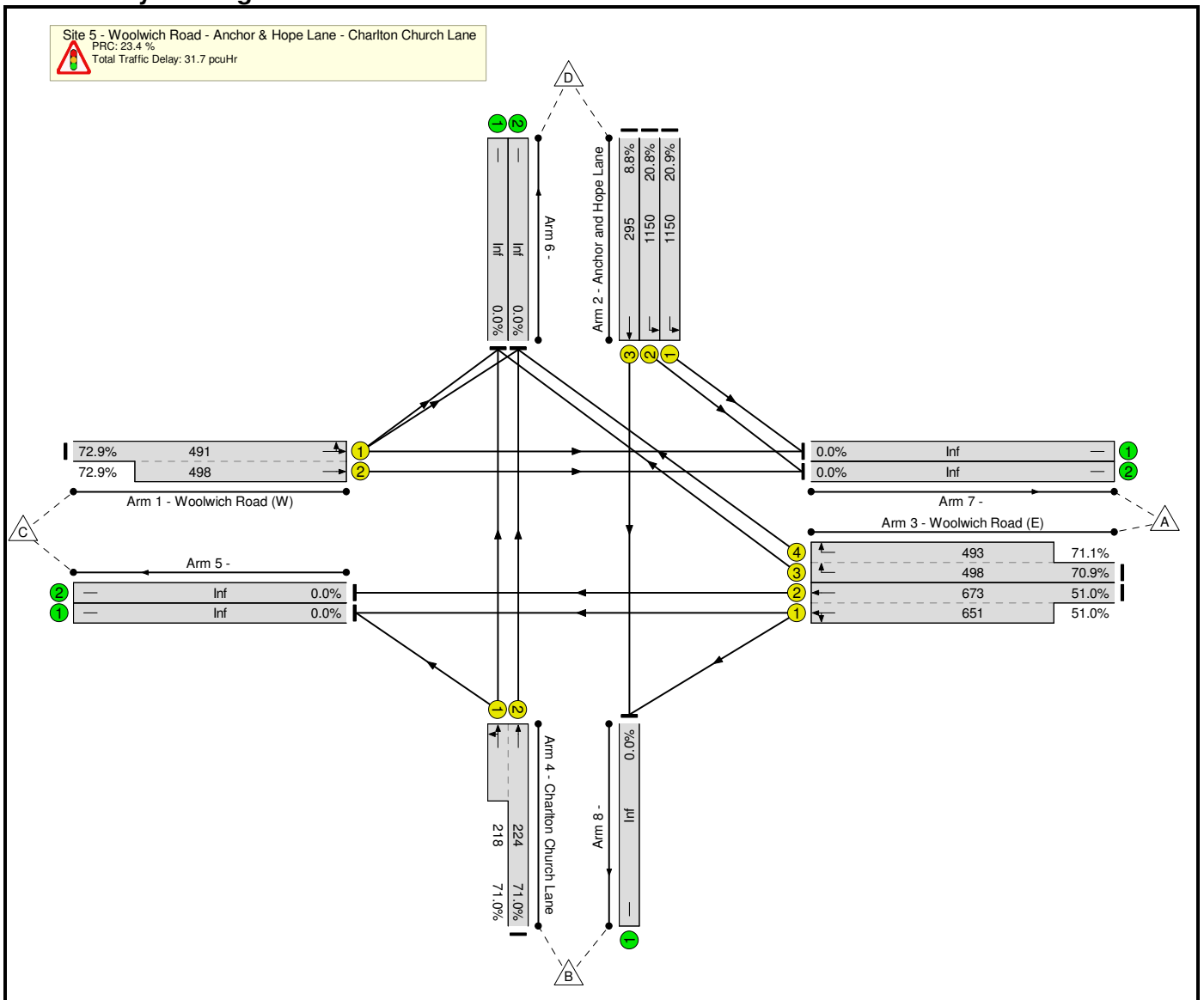

Basic Results Summary

**Network Results**

Item	Lane Description	Lane Type	Full Phase	Arrow Phase	Num Greens	Total Green (s)	Arrow Green (s)	Demand Flow (pcu)	Sat Flow (pcu/Hr)	Capacity (pcu)	Deg Sat (%)	Turners In Gaps (pcu)	Turners When Unopposed (pcu)	Turners In Intergreen (pcu)	Total Delay (pcuHr)	Av. Delay Per PCU (s/pcu)	Mean Max Queue (pcu)
<b>Network</b>	-	-	-		-	-	-	-	-	-	<b>72.9%</b>	<b>0</b>	<b>0</b>	<b>0</b>	<b>31.7</b>	-	-
<b>Site 5 - Woolwich Road - Anchor &amp; Hope Lane - Charlton Church Lane</b>	-	-	-		-	-	-	-	-	-	<b>72.9%</b>	<b>0</b>	<b>0</b>	<b>0</b>	<b>31.7</b>	-	-
1/1+1/2	Woolwich Road (W) Left Ahead	U	B		1	29	-	721	2030:2055	491+498	72.9 : 72.9%	-	-	-	9.5	47.6	12.3
2/1	Anchor and Hope Lane Left	U	D		1	70	-	240	1944	1150	20.9%	-	-	-	0.9	13.4	3.8
2/2	Anchor and Hope Lane Left	U	D		1	70	-	239	1944	1150	20.8%	-	-	-	0.9	13.4	3.8
2/3	Anchor and Hope Lane Ahead	U	E		1	17	-	26	1965	295	8.8%	-	-	-	0.4	50.7	0.8
3/2+3/1	Woolwich Road (E) Ahead Left	U	A		1	46	-	675	2005:1939	673+651	51.0 : 51.0%	-	-	-	5.5	29.6	8.9
3/3+3/4	Woolwich Road (E) Right	U	C		1	31	-	703	1868:1847	498+493	70.9 : 71.1%	-	-	-	9.0	46.0	11.8
4/2+4/1	Charlton Church Lane Left Ahead	U	F		1	15	-	314	1985:1926	224+218	71.0 : 71.0%	-	-	-	5.5	62.8	6.2
		C1	PRC for Signalled Lanes (%):		23.4		23.4	Total Delay for Signalled Lanes (pcuHr):		31.69		Cycle Time (s):		120			
			PRC Over All Lanes (%):		23.4			Total Delay Over All Lanes(pcuHr):		31.69							

Basic Results Summary

Scenario 2: 'Baseline PM Peak' (FG2: 'Baseline PM Peak', Plan 1: 'Network Control Plan 1')

Network Layout Diagram

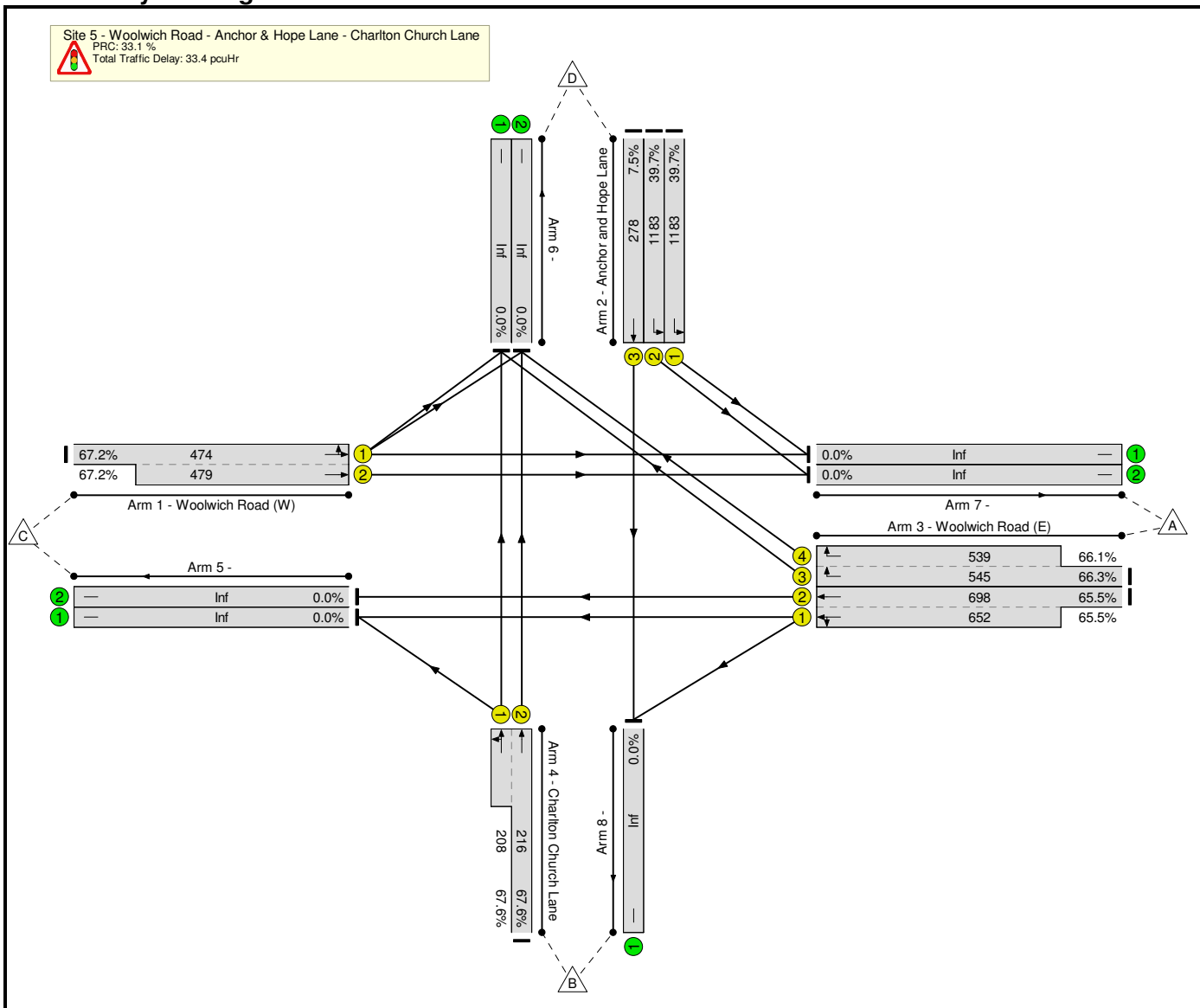

Basic Results Summary

**Network Results**

Item	Lane Description	Lane Type	Full Phase	Arrow Phase	Num Greens	Total Green (s)	Arrow Green (s)	Demand Flow (pcu)	Sat Flow (pcu/Hr)	Capacity (pcu)	Deg Sat (%)	Turners In Gaps (pcu)	Turners When Unopposed (pcu)	Turners In Intergreen (pcu)	Total Delay (pcuHr)	Av. Delay Per PCU (s/pcu)	Mean Max Queue (pcu)			
<b>Network</b>	-	-	-		-	-	-	-	-	-	67.6%	0	0	0	33.4	-	-			
<b>Site 5 - Woolwich Road - Anchor &amp; Hope Lane - Charlton Church Lane</b>	-	-	-		-	-	-	-	-	-	67.6%	0	0	0	33.4	-	-			
1/1+1/2	Woolwich Road (W) Left Ahead	U	B		1	27	-	641	2033:2055	474+479	67.2 : 67.2%	-	-	-	8.5	47.6	10.8			
2/1	Anchor and Hope Lane Left	U	D		1	72	-	470	1944	1183	39.7%	-	-	-	1.9	14.7	8.3			
2/2	Anchor and Hope Lane Left	U	D		1	72	-	469	1944	1183	39.7%	-	-	-	1.9	14.7	8.3			
2/3	Anchor and Hope Lane Ahead	U	E		1	16	-	21	1965	278	7.5%	-	-	-	0.3	51.7	0.6			
3/2+3/1	Woolwich Road (E) Ahead Left	U	A		1	49	-	884	2005:1871	698+652	65.5 : 65.5%	-	-	-	7.4	30.3	12.4			
3/3+3/4	Woolwich Road (E) Right	U	C		1	34	-	717	1868:1847	545+539	66.3 : 66.1%	-	-	-	8.4	42.2	11.5			
4/2+4/1	Charlton Church Lane Left Ahead	U	F		1	14	-	287	1985:1904	216+208	67.6 : 67.6%	-	-	-	5.0	62.5	5.6			
		C1	PRC for Signalled Lanes (%):		33.1		PRC Over All Lanes (%):		33.1		Total Delay for Signalled Lanes (pcuHr):		33.42		Total Delay Over All Lanes(pcuHr):		33.42		Cycle Time (s): 120	

Basic Results Summary

**Scenario 3: 'Baseline Plus Proposed Development AM Peak'** (FG3: 'Baseline Plus Proposed Development AM Peak', Plan 1: 'Network Control Plan 1')

**Network Layout Diagram**

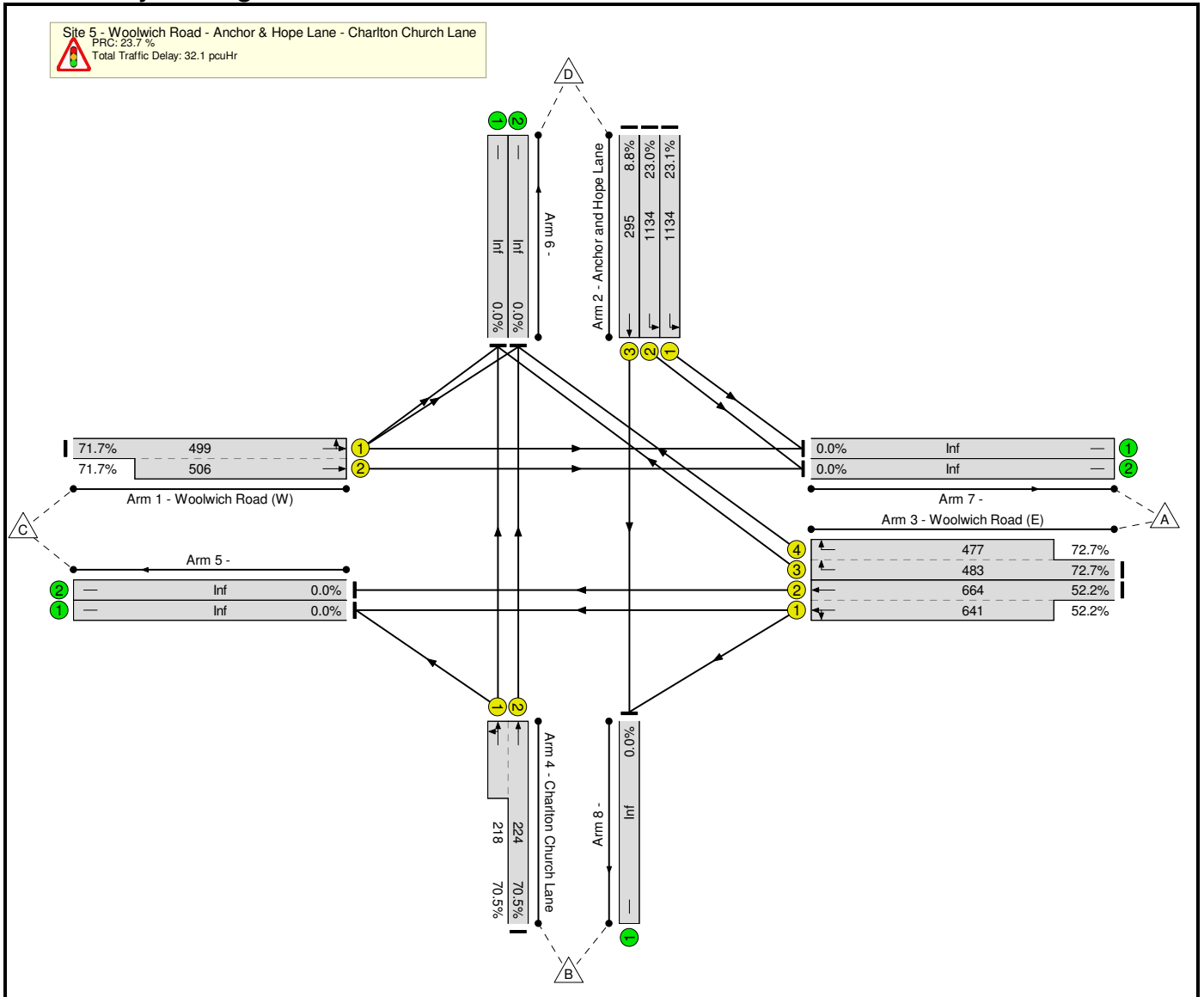

Basic Results Summary

**Network Results**

Item	Lane Description	Lane Type	Full Phase	Arrow Phase	Num Greens	Total Green (s)	Arrow Green (s)	Demand Flow (pcu)	Sat Flow (pcu/Hr)	Capacity (pcu)	Deg Sat (%)	Turners In Gaps (pcu)	Turners When Unopposed (pcu)	Turners In Intergreen (pcu)	Total Delay (pcuHr)	Av. Delay Per PCU (s/pcu)	Mean Max Queue (pcu)
<b>Network</b>	-	-	-		-	-	-	-	-	-	<b>72.7%</b>	<b>0</b>	<b>0</b>	<b>0</b>	<b>32.1</b>	-	-
<b>Site 5 - Woolwich Road - Anchor &amp; Hope Lane - Charlton Church Lane</b>	-	-	-		-	-	-	-	-	-	<b>72.7%</b>	<b>0</b>	<b>0</b>	<b>0</b>	<b>32.1</b>	-	-
1/1+1/2	Woolwich Road (W) Left Ahead	U	B		1	30	-	721	2030:2055	499+506	71.7 : 71.7%	-	-	-	9.3	46.3	12.1
2/1	Anchor and Hope Lane Left	U	D		1	69	-	262	1944	1134	23.1%	-	-	-	1.0	14.1	4.3
2/2	Anchor and Hope Lane Left	U	D		1	69	-	261	1944	1134	23.0%	-	-	-	1.0	14.1	4.3
2/3	Anchor and Hope Lane Ahead	U	E		1	17	-	26	1965	295	8.8%	-	-	-	0.4	50.7	0.8
3/2+3/1	Woolwich Road (E) Ahead Left	U	A		1	45	-	682	2005:1935	664+641	52.2 : 52.2%	-	-	-	5.8	30.5	9.1
3/3+3/4	Woolwich Road (E) Right	U	C		1	30	-	698	1868:1847	483+477	72.7 : 72.7%	-	-	-	9.2	47.5	11.9
4/2+4/1	Charlton Church Lane Left Ahead	U	F		1	15	-	312	1985:1926	224+218	70.5 : 70.5%	-	-	-	5.4	62.5	6.1
		C1	PRC for Signalled Lanes (%):		23.7		23.7	Total Delay for Signalled Lanes (pcuHr):		32.09		Cycle Time (s):		120			
			PRC Over All Lanes (%):		23.7			Total Delay Over All Lanes(pcuHr):		32.09							

Basic Results Summary

**Scenario 4: 'Baseline Plus Proposed Development PM Peak'** (FG4: 'Baseline Plus Proposed Development PM Peak', Plan 1: 'Network Control Plan 1')

**Network Layout Diagram**

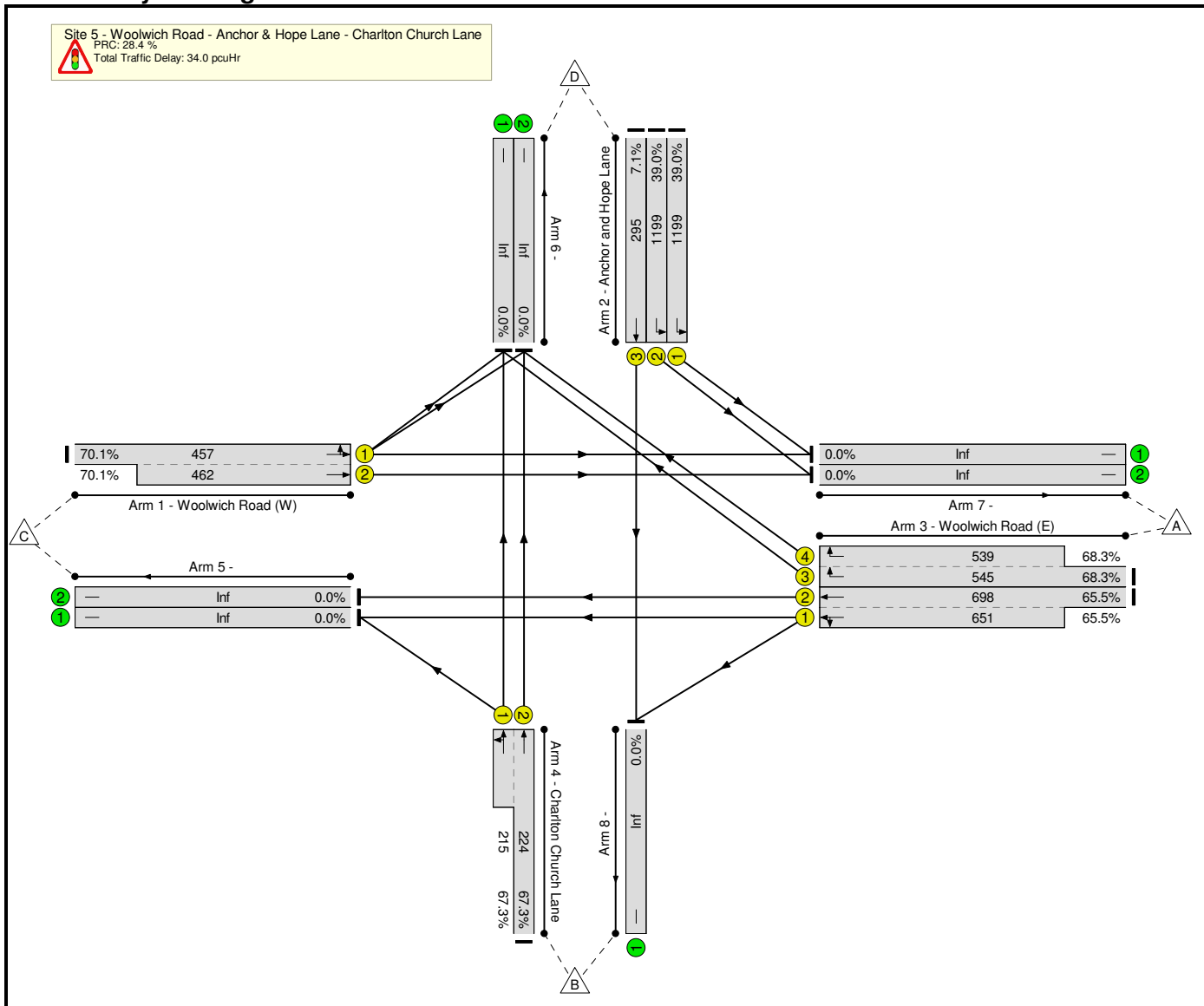

Basic Results Summary

**Network Results**

Item	Lane Description	Lane Type	Full Phase	Arrow Phase	Num Greens	Total Green (s)	Arrow Green (s)	Demand Flow (pcu)	Sat Flow (pcu/Hr)	Capacity (pcu)	Deg Sat (%)	Turners In Gaps (pcu)	Turners When Unopposed (pcu)	Turners In Intergreen (pcu)	Total Delay (pcuHr)	Av. Delay Per PCU (s/pcu)	Mean Max Queue (pcu)
<b>Network</b>	-	-	-		-	-	-	-	-	-	70.1%	0	0	0	34.0	-	-
<b>Site 5 - Woolwich Road - Anchor &amp; Hope Lane - Charlton Church Lane</b>	-	-	-		-	-	-	-	-	-	70.1%	0	0	0	34.0	-	-
1/1+1/2	Woolwich Road (W) Left Ahead	U	B		1	26	-	644	2030:2055	457+462	70.1 : 70.1%	-	-	-	8.8	49.3	11.1
2/1	Anchor and Hope Lane Left	U	D		1	73	-	467	1944	1199	39.0%	-	-	-	1.8	14.1	8.1
2/2	Anchor and Hope Lane Left	U	D		1	73	-	467	1944	1199	39.0%	-	-	-	1.8	14.1	8.1
2/3	Anchor and Hope Lane Ahead	U	E		1	17	-	21	1965	295	7.1%	-	-	-	0.3	50.4	0.6
3/2+3/1	Woolwich Road (E) Ahead Left	U	A		1	49	-	883	2005:1872	698+651	65.5 : 65.5%	-	-	-	7.4	30.3	12.4
3/3+3/4	Woolwich Road (E) Right	U	C		1	34	-	740	1868:1847	545+539	68.3 : 68.3%	-	-	-	8.8	42.8	12.0
4/2+4/1	Charlton Church Lane Left Ahead	U	F		1	15	-	296	1985:1906	224+215	67.3 : 67.3%	-	-	-	5.0	61.1	5.7
		C1	PRC for Signalled Lanes (%):		28.4		28.4	Total Delay for Signalled Lanes (pcuHr):		34.01		Cycle Time (s):		120			
			PRC Over All Lanes (%):		28.4			Total Delay Over All Lanes(pcuHr):		34.01							

Basic Results Summary

**Scenario 5: 'Baseline Plus Other Cumulative Developments AM Peak'** (FG5: 'Baseline Plus Other Cumulative Developments AM Peak', Plan 1: 'Network Control Plan 1')

**Network Layout Diagram**

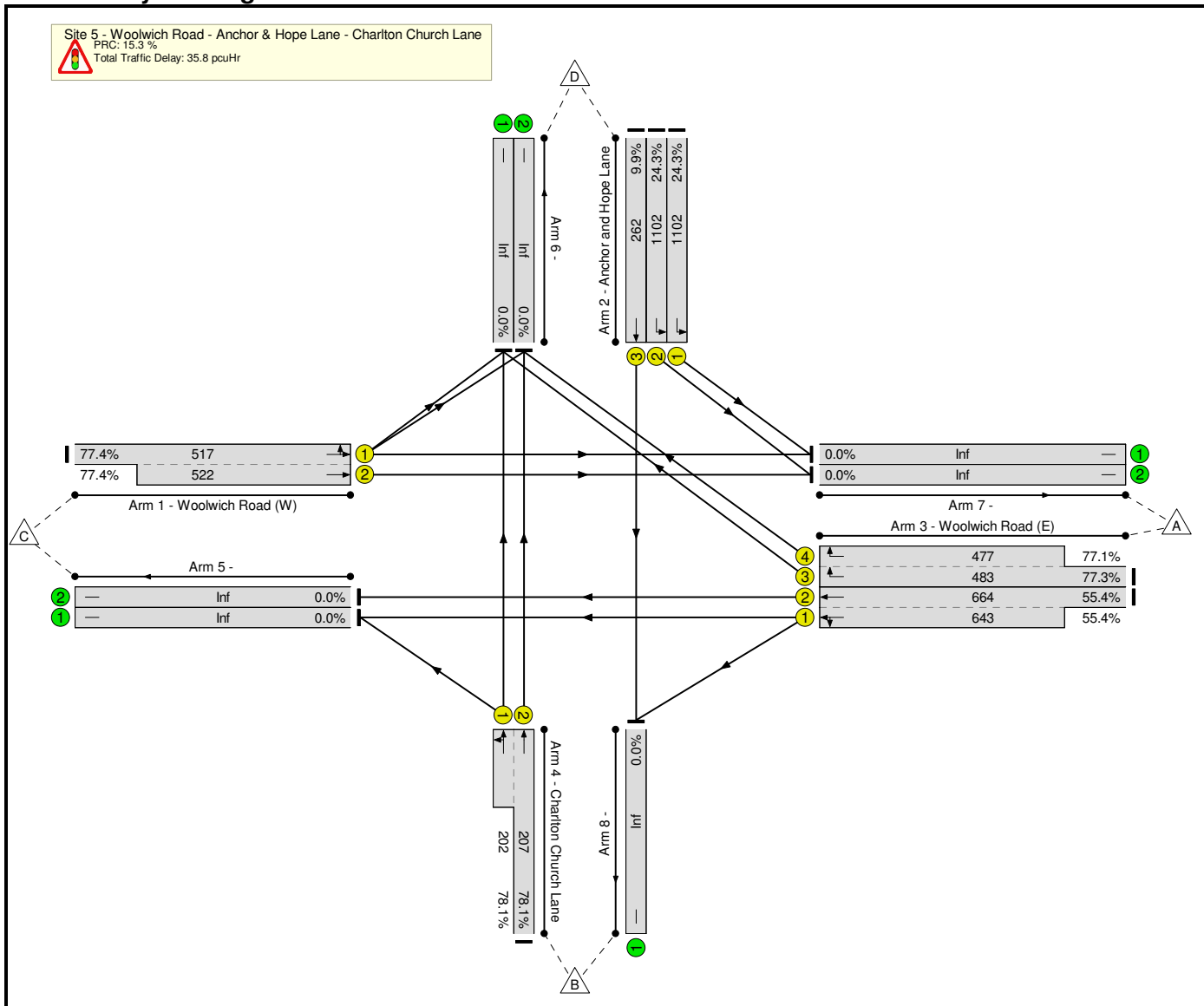

Basic Results Summary

**Network Results**

Item	Lane Description	Lane Type	Full Phase	Arrow Phase	Num Greens	Total Green (s)	Arrow Green (s)	Demand Flow (pcu)	Sat Flow (pcu/Hr)	Capacity (pcu)	Deg Sat (%)	Turners In Gaps (pcu)	Turners When Unopposed (pcu)	Turners In Intergreen (pcu)	Total Delay (pcuHr)	Av. Delay Per PCU (s/pcu)	Mean Max Queue (pcu)			
<b>Network</b>	-	-	-		-	-	-	-	-	-	<b>78.1%</b>	<b>0</b>	<b>0</b>	<b>0</b>	<b>35.8</b>	-	-			
<b>Site 5 - Woolwich Road - Anchor &amp; Hope Lane - Charlton Church Lane</b>	-	-	-		-	-	-	-	-	-	<b>78.1%</b>	<b>0</b>	<b>0</b>	<b>0</b>	<b>35.8</b>	-	-			
1/1+1/2	Woolwich Road (W) Left Ahead	U	B		1	32	-	804	2033:2055	517+522	77.4 : 77.4%	-	-	-	10.5	46.8	13.8			
2/1	Anchor and Hope Lane Left	U	D		1	67	-	268	1944	1102	24.3%	-	-	-	1.1	15.2	4.6			
2/2	Anchor and Hope Lane Left	U	D		1	67	-	268	1944	1102	24.3%	-	-	-	1.1	15.2	4.6			
2/3	Anchor and Hope Lane Ahead	U	E		1	15	-	26	1965	262	9.9%	-	-	-	0.4	53.4	0.8			
3/2+3/1	Woolwich Road (E) Ahead Left	U	A		1	45	-	724	2005:1938	664+643	55.4 : 55.4%	-	-	-	6.2	31.0	9.8			
3/3+3/4	Woolwich Road (E) Right	U	C		1	30	-	741	1868:1847	483+477	77.3 : 77.1%	-	-	-	10.2	49.3	13.2			
4/2+4/1	Charlton Church Lane Left Ahead	U	F		1	13	-	320	1985:1927	207+202	78.1 : 78.1%	-	-	-	6.2	70.3	6.9			
		C1	PRC for Signalled Lanes (%):		15.3		Arrow Green (s):		15.3		Total Delay for Signalled Lanes (pcuHr):		35.75		Total Delay Over All Lanes(pcuHr):		35.75		Cycle Time (s): 120	

Basic Results Summary

**Scenario 6: 'Baseline Plus Other Cumulative Developments PM Peak'** (FG6: 'Baseline Plus Other Cumulative Developments PM Peak', Plan 1: 'Network Control Plan 1')

**Network Layout Diagram**

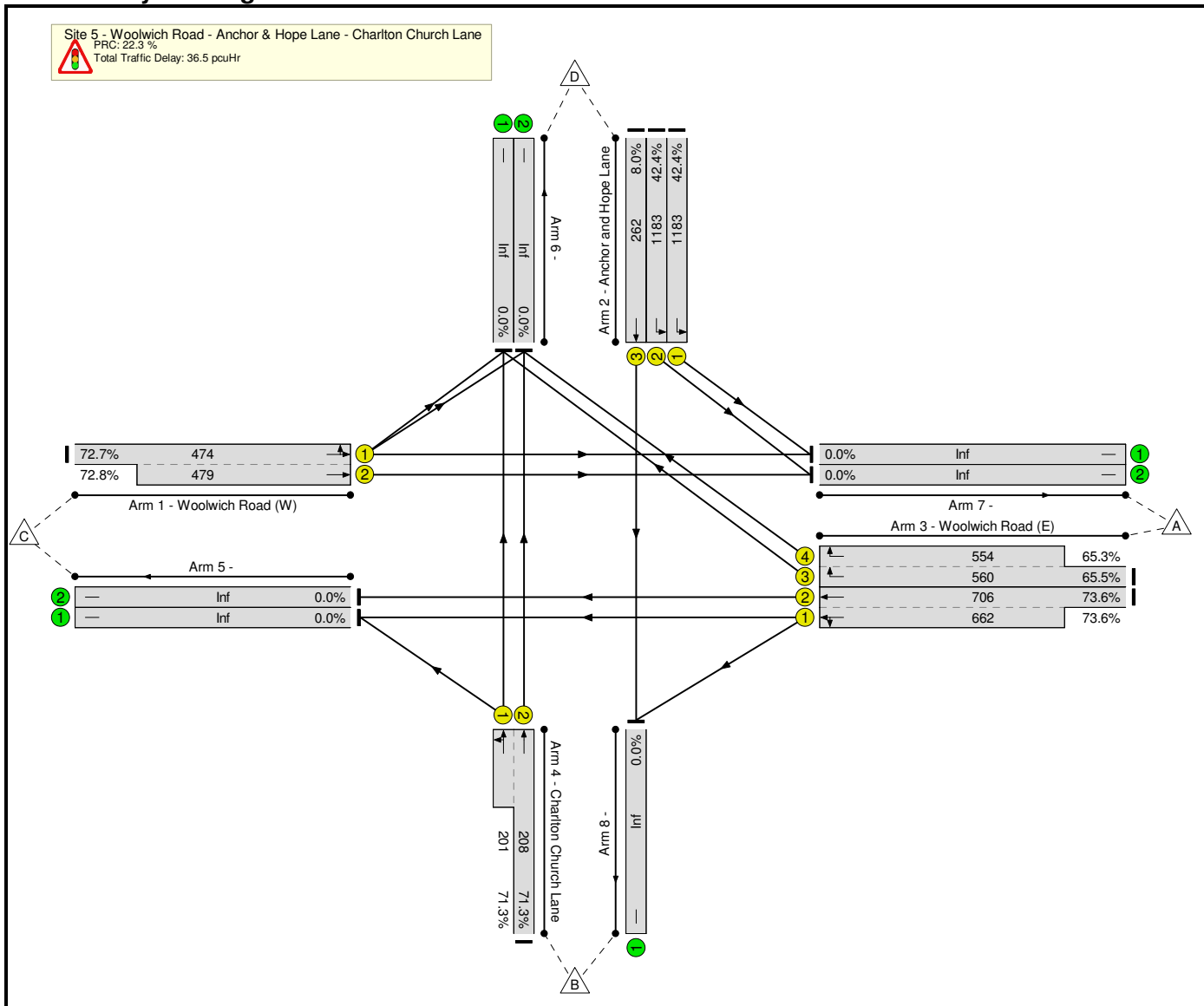

Basic Results Summary

**Network Results**

Item	Lane Description	Lane Type	Full Phase	Arrow Phase	Num Greens	Total Green (s)	Arrow Green (s)	Demand Flow (pcu)	Sat Flow (pcu/Hr)	Capacity (pcu)	Deg Sat (%)	Turners In Gaps (pcu)	Turners When Unopposed (pcu)	Turners In Intergreen (pcu)	Total Delay (pcuHr)	Av. Delay Per PCU (s/pcu)	Mean Max Queue (pcu)
<b>Network</b>	-	-	-		-	-	-	-	-	-	73.6%	0	0	0	36.5	-	-
<b>Site 5 - Woolwich Road - Anchor &amp; Hope Lane - Charlton Church Lane</b>	-	-	-		-	-	-	-	-	-	73.6%	0	0	0	36.5	-	-
1/1+1/2	Woolwich Road (W) Left Ahead	U	B		1	27	-	694	2034:2055	474+479	72.7 : 72.8%	-	-	-	9.5	49.3	12.0
2/1	Anchor and Hope Lane Left	U	D		1	72	-	501	1944	1183	42.4%	-	-	-	2.1	15.0	9.1
2/2	Anchor and Hope Lane Left	U	D		1	72	-	501	1944	1183	42.4%	-	-	-	2.1	15.0	9.1
2/3	Anchor and Hope Lane Ahead	U	E		1	15	-	21	1965	262	8.0%	-	-	-	0.3	53.1	0.7
3/2+3/1	Woolwich Road (E) Ahead Left	U	A		1	50	-	1007	2005:1880	706+662	73.6 : 73.6%	-	-	-	8.9	31.7	14.8
3/3+3/4	Woolwich Road (E) Right	U	C		1	35	-	729	1868:1847	560+554	65.5 : 65.3%	-	-	-	8.3	41.2	11.5
4/2+4/1	Charlton Church Lane Left Ahead	U	F		1	13	-	291	1985:1905	208+201	71.3 : 71.3%	-	-	-	5.3	65.7	5.9
		C1	PRC for Signalled Lanes (%):		22.3		22.3		Total Delay for Signalled Lanes (pcuHr):		36.54		Cycle Time (s):		120		
			PRC Over All Lanes (%):		22.3				Total Delay Over All Lanes(pcuHr):		36.54						

Basic Results Summary

**Scenario 7: 'Cumulative Development Scenario AM Peak'** (FG7: 'Cumulative Development Scenario AM Peak', Plan 1: 'Network Control Plan 1')

**Network Layout Diagram**

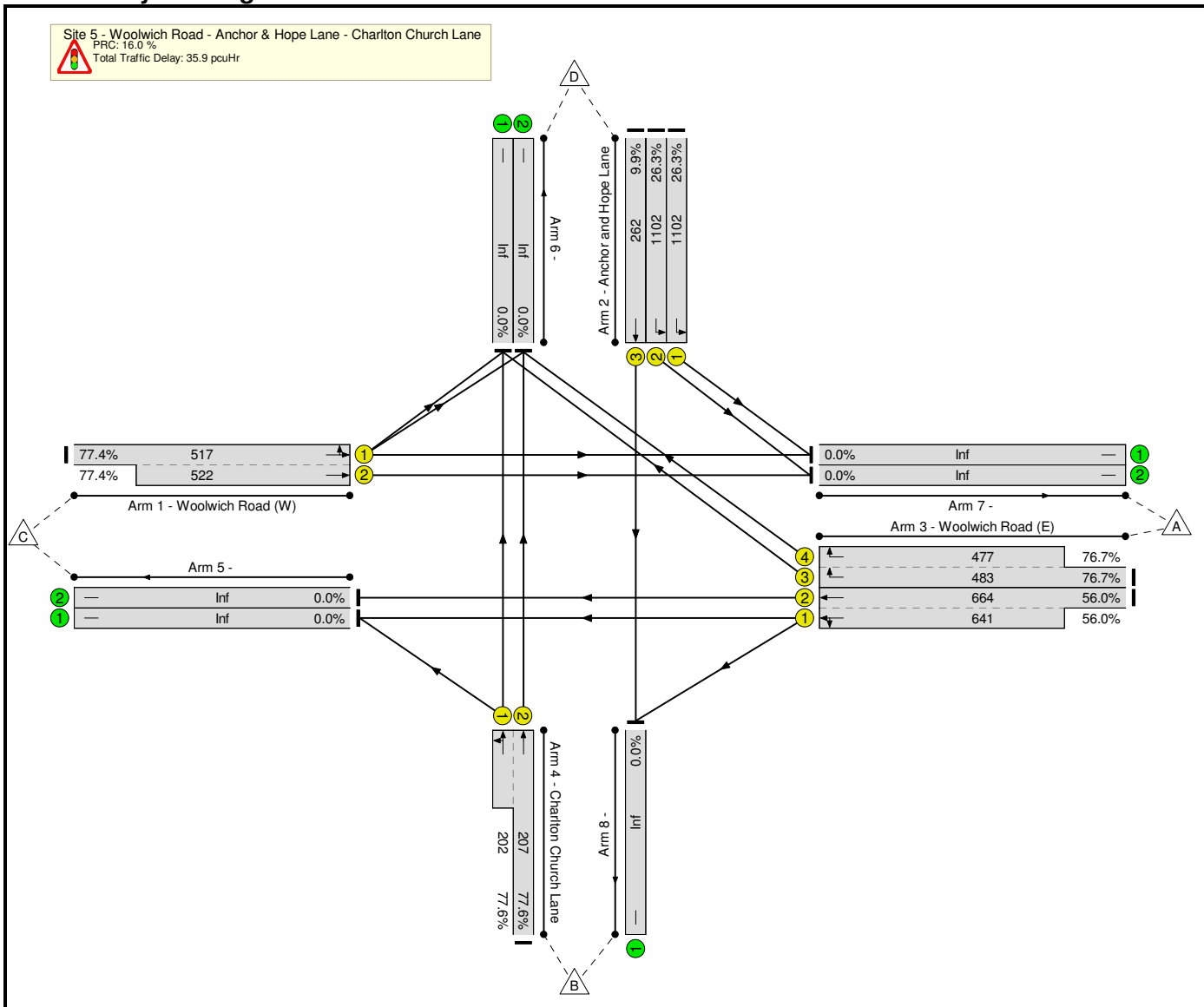

Basic Results Summary

**Network Results**

Item	Lane Description	Lane Type	Full Phase	Arrow Phase	Num Greens	Total Green (s)	Arrow Green (s)	Demand Flow (pcu)	Sat Flow (pcu/Hr)	Capacity (pcu)	Deg Sat (%)	Turners In Gaps (pcu)	Turners When Unopposed (pcu)	Turners In Intergreen (pcu)	Total Delay (pcuHr)	Av. Delay Per PCU (s/pcu)	Mean Max Queue (pcu)	
<b>Network</b>	-	-	-		-	-	-	-	-	-	77.6%	0	0	0	35.9	-	-	
<b>Site 5 - Woolwich Road - Anchor &amp; Hope Lane - Charlton Church Lane</b>	-	-	-		-	-	-	-	-	-	77.6%	0	0	0	35.9	-	-	
1/1+1/2	Woolwich Road (W) Left Ahead	U	B		1	32	-	804	2033:2055	517+522	77.4 : 77.4%	-	-	-	10.5	46.8	13.8	
2/1	Anchor and Hope Lane Left	U	D		1	67	-	290	1944	1102	26.3%	-	-	-	1.2	15.5	5.1	
2/2	Anchor and Hope Lane Left	U	D		1	67	-	290	1944	1102	26.3%	-	-	-	1.2	15.5	5.1	
2/3	Anchor and Hope Lane Ahead	U	E		1	15	-	26	1965	262	9.9%	-	-	-	0.4	53.4	0.8	
3/2+3/1	Woolwich Road (E) Ahead Left	U	A		1	45	-	731	2005:1934	664+641	56.0 : 56.0%	-	-	-	6.3	31.1	9.9	
3/3+3/4	Woolwich Road (E) Right	U	C		1	30	-	736	1868:1847	483+477	76.7 : 76.7%	-	-	-	10.0	49.1	12.9	
4/2+4/1	Charlton Church Lane Left Ahead	U	F		1	13	-	318	1985:1927	207+202	77.6 : 77.6%	-	-	-	6.2	69.9	6.8	
		C1	PRC for Signalled Lanes (%):		16.0		16.0		Total Delay for Signalled Lanes (pcuHr):		35.87		Cycle Time (s):		120			
			PRC Over All Lanes (%):		16.0				Total Delay Over All Lanes(pcuHr):		35.87							

Basic Results Summary

**Scenario 8: 'Cumulative Development Scenario PM Peak'** (FG8: 'Cumulative Development Scenario PM Peak', Plan 1: 'Network Control Plan 1')

**Network Layout Diagram**

Site 5 - Woolwich Road - Anchor & Hope Lane - Charlton Church Lane  
 PRC: 22.5 %  
 Total Traffic Delay: 38.3 pcuHr

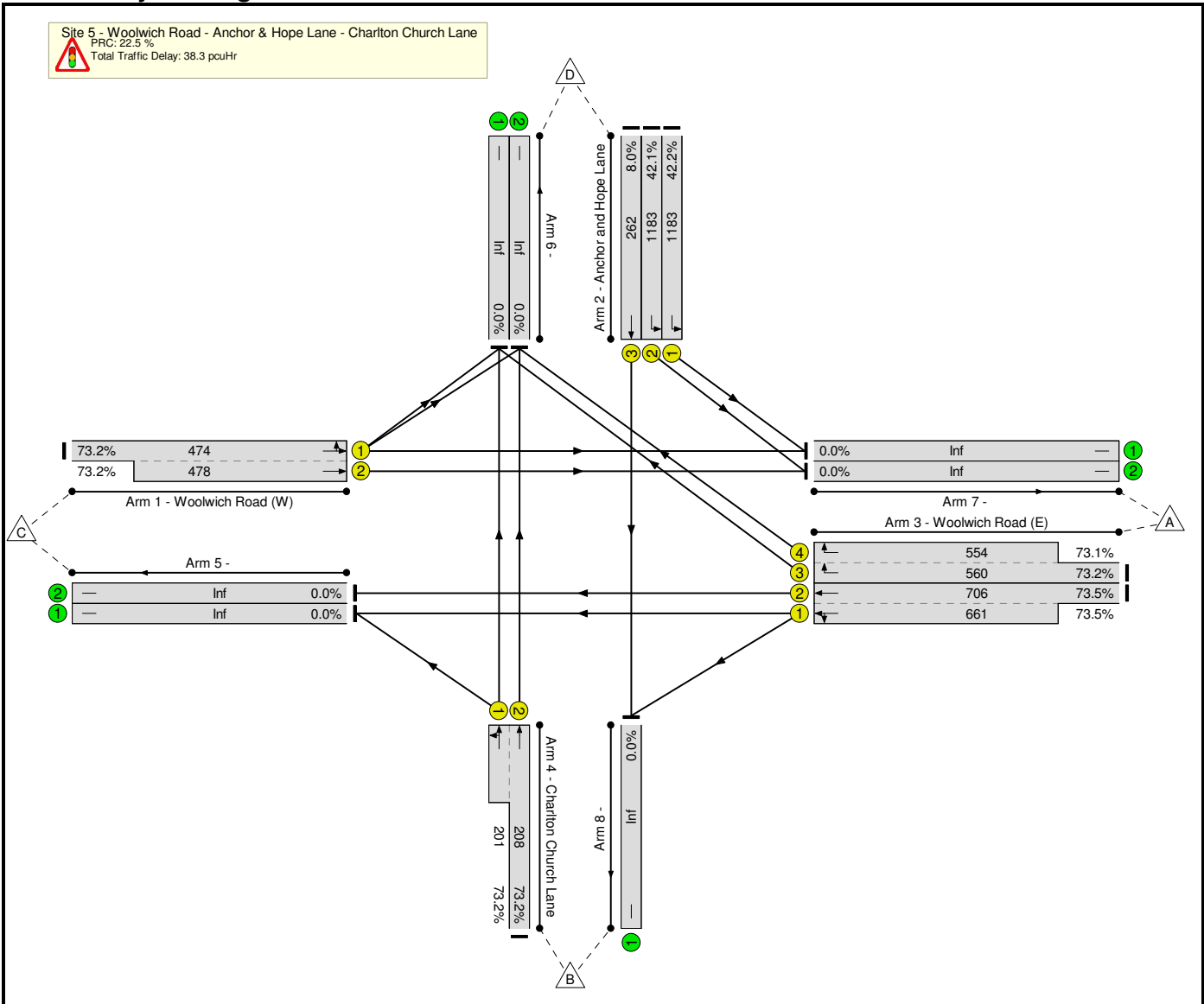

Basic Results Summary

**Network Results**

Item	Lane Description	Lane Type	Full Phase	Arrow Phase	Num Greens	Total Green (s)	Arrow Green (s)	Demand Flow (pcu)	Sat Flow (pcu/Hr)	Capacity (pcu)	Deg Sat (%)	Turners In Gaps (pcu)	Turners When Unopposed (pcu)	Turners In Intergreen (pcu)	Total Delay (pcuHr)	Av. Delay Per PCU (s/pcu)	Mean Max Queue (pcu)	
<b>Network</b>	-	-	-		-	-	-	-	-	-	73.5%	0	0	0	38.3	-	-	
<b>Site 5 - Woolwich Road - Anchor &amp; Hope Lane - Charlton Church Lane</b>	-	-	-		-	-	-	-	-	-	73.5%	0	0	0	38.3	-	-	
1/1+1/2	Woolwich Road (W) Left Ahead	U	B		1	27	-	697	2032:2055	474+478	73.2 : 73.2%	-	-	-	9.6	49.5	12.0	
2/1	Anchor and Hope Lane Left	U	D		1	72	-	499	1944	1183	42.2%	-	-	-	2.1	15.0	9.1	
2/2	Anchor and Hope Lane Left	U	D		1	72	-	498	1944	1183	42.1%	-	-	-	2.1	15.0	9.1	
2/3	Anchor and Hope Lane Ahead	U	E		1	15	-	21	1965	262	8.0%	-	-	-	0.3	53.1	0.7	
3/2+3/1	Woolwich Road (E) Ahead Left	U	A		1	50	-	1005	2005:1881	706+661	73.5 : 73.5%	-	-	-	8.8	31.7	14.8	
3/3+3/4	Woolwich Road (E) Right	U	C		1	35	-	815	1868:1847	560+554	73.2 : 73.1%	-	-	-	9.9	43.6	13.5	
4/2+4/1	Charlton Church Lane Left Ahead	U	F		1	13	-	299	1985:1907	208+201	73.2 : 73.2%	-	-	-	5.5	66.8	6.1	
		C1	PRC for Signalled Lanes (%):		22.5		22.5		Total Delay for Signalled Lanes (pcuHr):		38.31		Cycle Time (s):		120			
			PRC Over All Lanes (%):		22.5				Total Delay Over All Lanes(pcuHr):		38.31							

**Appendix G**  
**Woolwich Road/Retail Park**  
**Access/Gallon Close ARCADY**  
**Results**

<b>Junctions 9</b>
<b>ARCADY 9 - Roundabout Module</b>
Version: 9.0.0.4211 [] © Copyright TRL Limited, 2017
For sales and distribution information, program advice and maintenance, contact TRL: Tel: +44 (0)1344 770758 email: software@trl.co.uk Web: http://www.trlsoftware.co.uk
The users of this computer program for the solution of an engineering problem are in no way relieved of their responsibility for the correctness of the solution

**Filename:** Site 6 - Woolwich Road - Retail Park - Gallon Close.j9  
**Path:** T:\30000\_Projects\30821 Charlton Riverside, Greenwich\Junction modelling\Site 6  
**Report generation date:** 04/12/2017 11:34:55

- »2016 Baseline, AM
- »2016 Baseline, PM
- »Baseline Plus Proposed Development, AM
- »Baseline Plus Proposed Development, PM
- »Baseline Plus Other Cumulative Developments, AM
- »Baseline Plus Other Cumulative Developments, PM
- »Cumulative Development Scenario, AM
- »Cumulative Development Scenario, PM

### Summary of junction performance

	AM				PM			
	Queue (Veh)	Delay (s)	RFC	LOS	Queue (Veh)	Delay (s)	RFC	LOS
<b>2016 Baseline</b>								
1 - Stone Lake Retail Park	0.0	5.01	0.01	A	0.2	9.01	0.18	A
2 - Woolwich Road (E)	1.4	3.96	0.59	A	1.8	4.54	0.64	A
3 - York Terrace	0.0	9.68	0.03	A	0.0	14.05	0.02	B
4 - Woolwich Road (W)	1.0	3.14	0.50	A	2.3	4.88	0.70	A
<b>Baseline Plus Proposed Development</b>								
1 - Stone Lake Retail Park	0.0	5.23	0.01	A	0.2	8.95	0.18	A
2 - Woolwich Road (E)	1.4	3.96	0.59	A	1.9	4.69	0.65	A
3 - York Terrace	0.0	9.71	0.03	A	0.0	14.87	0.02	B
4 - Woolwich Road (W)	1.1	3.28	0.52	A	2.3	4.86	0.70	A
<b>Baseline Plus Other Cumulative Developments</b>								
1 - Stone Lake Retail Park	0.0	5.76	0.01	A	0.3	11.17	0.22	B
2 - Woolwich Road (E)	1.7	4.31	0.63	A	2.8	6.22	0.74	A
3 - York Terrace	0.0	11.11	0.03	B	0.0	26.43	0.04	D
4 - Woolwich Road (W)	1.3	3.59	0.57	A	3.0	5.94	0.75	A
<b>Cumulative Development Scenario</b>								
1 - Stone Lake Retail Park	0.0	5.97	0.01	A	0.3	11.08	0.22	B
2 - Woolwich Road (E)	1.7	4.31	0.63	A	2.8	6.28	0.74	A
3 - York Terrace	0.0	11.13	0.03	B	0.0	27.59	0.04	D
4 - Woolwich Road (W)	1.4	3.69	0.58	A	3.0	5.90	0.75	A

Values shown are the highest values encountered over all time segments. Delay is the maximum value of average delay per arriving vehicle.

## File summary

### File Description

<b>Title</b>	(untitled)
<b>Location</b>	
<b>Site number</b>	
<b>Date</b>	30/08/2016
<b>Version</b>	
<b>Status</b>	(new file)
<b>Identifier</b>	
<b>Client</b>	
<b>Jobnumber</b>	
<b>Enumerator</b>	TPP111"techuser
<b>Description</b>	

## Units

Distance units	Speed units	Traffic units input	Traffic units results	Flow units	Average delay units	Total delay units	Rate of delay units
m	kph	Veh	Veh	perHour	s	-Min	perMin

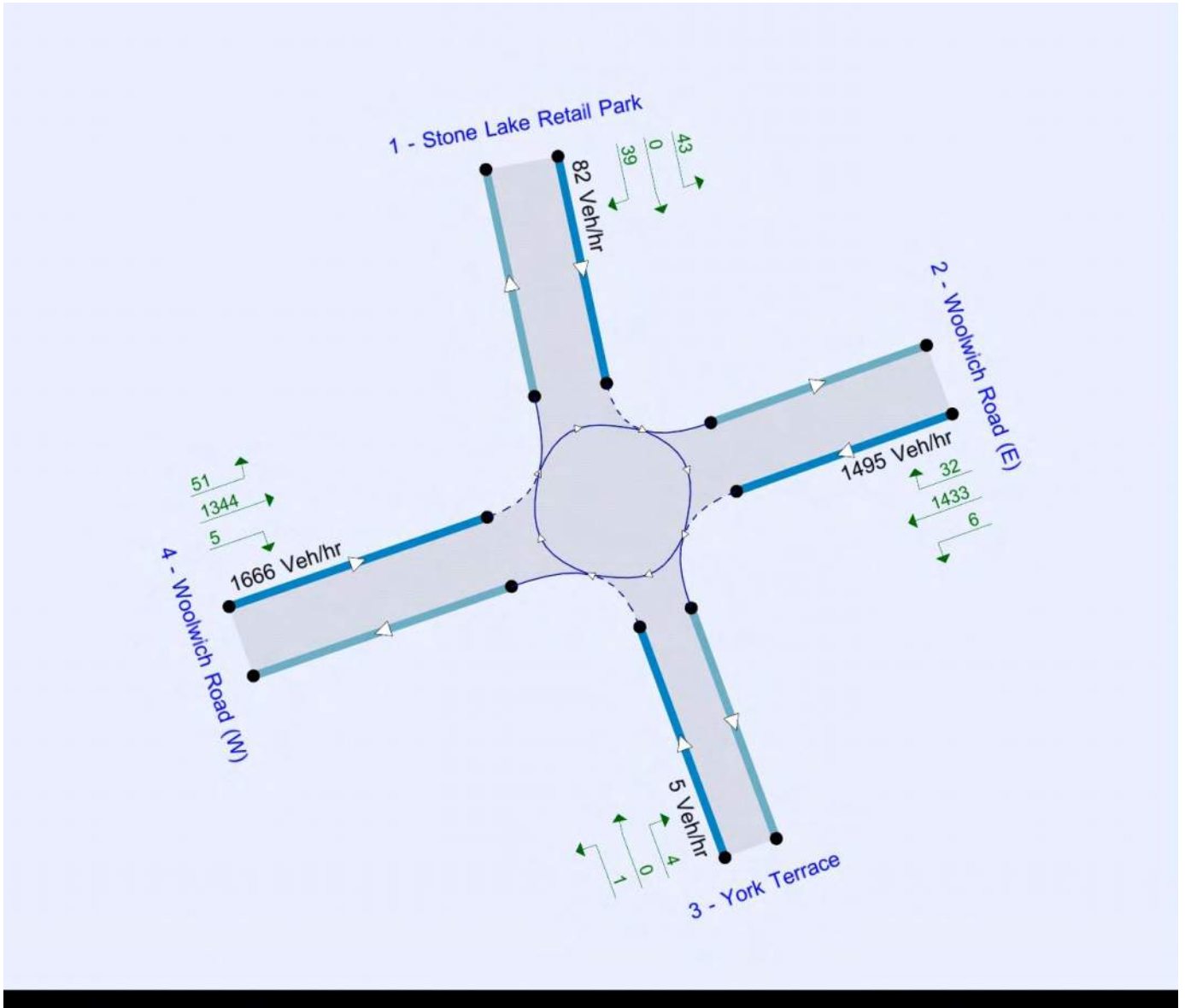

The junction diagram reflects the last run of Junctions.

### Analysis Options

Calculate Queue Percentiles	Calculate residual capacity	RFC Threshold	Average Delay threshold (s)	Queue threshold (PCU)
		0.85	36.00	20.00

## Demand Set Summary

Scenario name	Time Period name	Traffic profile type	Model start time (HH:mm)	Model finish time (HH:mm)	Time segment length (min)
2016 Baseline	AM	ONE HOUR	08:00	09:30	15
2016 Baseline	PM	ONE HOUR	17:00	18:30	15
Baseline Plus Proposed Development	AM	ONE HOUR	08:00	09:30	15
Baseline Plus Proposed Development	PM	ONE HOUR	17:00	18:30	15
Baseline Plus Other Cumulative Developments	AM	ONE HOUR	08:00	09:30	15
Baseline Plus Other Cumulative Developments	PM	ONE HOUR	17:00	18:30	15
Cumulative Development Scenario	AM	ONE HOUR	08:00	09:30	15
Cumulative Development Scenario	PM	ONE HOUR	17:00	18:30	15

# 2016 Baseline, AM

## Data Errors and Warnings

*No errors or warnings*

## Analysis Set Details

ID	Network flow scaling factor (%)
A1	100.000

# Junction Network

## Junctions

Junction	Name	Junction Type	Junction Delay (s)	Junction LOS
1 - untitled	untitled	Standard Roundabout	3.60	A

## Junction Network Options

Driving side	Lighting
Left	Normal/unknown

# Arms

## Arms

Arm	Name	Description
1	Stone Lake Retail Park	
2	Woolwich Road (E)	
3	York Terrace	
4	Woolwich Road (W)	

## Capacity Options

Arm	Minimum capacity (PCU/hr)	Maximum capacity (PCU/hr)
1 - Stone Lake Retail Park	0.00	99999.00
2 - Woolwich Road (E)	0.00	99999.00
3 - York Terrace	0.00	99999.00
4 - Woolwich Road (W)	0.00	99999.00

## Roundabout Geometry

Arm	V - Approach road half-width (m)	E - Entry width (m)	I' - Effective flare length (m)	R - Entry radius (m)	D - Inscribed circle diameter (m)	PHI - Conflict (entry) angle (deg)	Exit only
1 - Stone Lake Retail Park	3.70	7.50	9.3	23.0	46.0	56.0	
2 - Woolwich Road (E)	8.90	10.60	3.2	20.0	46.0	62.0	
3 - York Terrace	2.70	5.00	10.2	9.0	46.0	15.0	
4 - Woolwich Road (W)	8.80	10.90	3.7	21.0	46.0	56.0	

## Slope / Intercept / Capacity

### Roundabout Slope and Intercept used in model

Arm	Final slope	Final intercept (PCU/hr)
1 - Stone Lake Retail Park	0.558	1484.246
2 - Woolwich Road (E)	0.760	2566.852
3 - York Terrace	0.528	1213.468
4 - Woolwich Road (W)	0.781	2638.129

The slope and intercept shown above include any corrections and adjustments.

## Traffic Demand

### Demand Set Details

ID	Scenario name	Time Period name	Traffic profile type	Model start time (HH:mm)	Model finish time (HH:mm)	Time segment length (min)
D1	2016 Baseline	AM	ONE HOUR	08:00	09:30	15

Vehicle mix varies over turn	Vehicle mix varies over entry	Vehicle mix source	PCU Factor for a HV (PCU)
✓	✓	HV Percentages	2.00

### Demand overview (Traffic)

Arm	Linked arm	Use O-D data	Average Demand (Veh/hr)	Scaling Factor (%)
1 - Stone Lake Retail Park		✓	8.00	100.000
2 - Woolwich Road (E)		✓	1198.00	100.000
3 - York Terrace		✓	9.00	100.000
4 - Woolwich Road (W)		✓	1055.00	100.000

## Origin-Destination Data

### Demand (Veh/hr)

		To			
		1 - Stone Lake Retail Park	2 - Woolwich Road (E)	3 - York Terrace	4 - Woolwich Road (W)
From	1 - Stone Lake Retail Park	0.000	2.000	0.000	6.000
	2 - Woolwich Road (E)	6.000	54.000	3.000	1135.000
	3 - York Terrace	0.000	3.000	0.000	6.000
	4 - Woolwich Road (W)	13.000	951.000	4.000	87.000

## Vehicle Mix

### Heavy Vehicle proportion

		To			
		1 - Stone Lake Retail Park	2 - Woolwich Road (E)	3 - York Terrace	4 - Woolwich Road (W)
From	1 - Stone Lake Retail Park	0	0	0	0
	2 - Woolwich Road (E)	0	19	0	11
	3 - York Terrace	0	0	0	0
	4 - Woolwich Road (W)	0	12	0	10

## Results

### Results Summary for whole modelled period

Arm	Max RFC	Max delay (s)	Max Queue (Veh)	Max LOS
1 - Stone Lake Retail Park	0.01	5.01	0.0	A
2 - Woolwich Road (E)	0.59	3.96	1.4	A
3 - York Terrace	0.03	9.68	0.0	A
4 - Woolwich Road (W)	0.50	3.14	1.0	A

### Main Results for each time segment

#### Main results: (08:00-08:15)

Arm	Total Demand (Veh/hr)	Circulating flow (Veh/hr)	Capacity (Veh/hr)	RFC	Throughput (Veh/hr)	End queue (Veh)	Delay (s)	LOS
1 - Stone Lake Retail Park	6.02	825.21	968.19	0.006	6.00	0.0	3.740	A
2 - Woolwich Road (E)	901.92	72.83	2252.49	0.400	899.26	0.7	2.656	A
3 - York Terrace	6.78	966.84	646.38	0.010	6.73	0.0	5.627	A
4 - Woolwich Road (W)	794.26	47.28	2324.58	0.342	792.19	0.5	2.346	A

**Main results: (08:15-08:30)**

Arm	Total Demand (Veh/hr)	Circulating flow (Veh/hr)	Capacity (Veh/hr)	RFC	Throughput (Veh/hr)	End queue (Veh)	Delay (s)	LOS
1 - Stone Lake Retail Park	7.19	987.25	866.86	0.008	7.18	0.0	4.187	A
2 - Woolwich Road (E)	1076.98	87.14	2241.85	0.480	1075.96	0.9	3.084	A
3 - York Terrace	8.09	1156.81	534.95	0.015	8.07	0.0	6.832	A
4 - Woolwich Road (W)	948.42	56.58	2317.02	0.409	947.73	0.7	2.627	A

**Main results: (08:30-08:45)**

Arm	Total Demand (Veh/hr)	Circulating flow (Veh/hr)	Capacity (Veh/hr)	RFC	Throughput (Veh/hr)	End queue (Veh)	Delay (s)	LOS
1 - Stone Lake Retail Park	8.81	1208.66	728.39	0.012	8.79	0.0	5.002	A
2 - Woolwich Road (E)	1319.02	106.68	2227.30	0.592	1316.95	1.4	3.946	A
3 - York Terrace	9.91	1415.93	382.97	0.026	9.87	0.0	9.647	A
4 - Woolwich Road (W)	1161.57	69.25	2306.71	0.504	1160.30	1.0	3.138	A

**Main results: (08:45-09:00)**

Arm	Total Demand (Veh/hr)	Circulating flow (Veh/hr)	Capacity (Veh/hr)	RFC	Throughput (Veh/hr)	End queue (Veh)	Delay (s)	LOS
1 - Stone Lake Retail Park	8.81	1210.01	727.55	0.012	8.81	0.0	5.008	A
2 - Woolwich Road (E)	1319.02	106.80	2227.21	0.592	1318.99	1.4	3.963	A
3 - York Terrace	9.91	1418.09	381.70	0.026	9.91	0.0	9.682	A
4 - Woolwich Road (W)	1161.57	69.36	2306.62	0.504	1161.56	1.0	3.143	A

**Main results: (09:00-09:15)**

Arm	Total Demand (Veh/hr)	Circulating flow (Veh/hr)	Capacity (Veh/hr)	RFC	Throughput (Veh/hr)	End queue (Veh)	Delay (s)	LOS
1 - Stone Lake Retail Park	7.19	989.33	865.55	0.008	7.21	0.0	4.195	A
2 - Woolwich Road (E)	1076.98	87.32	2241.71	0.480	1079.03	0.9	3.103	A
3 - York Terrace	8.09	1160.06	533.05	0.015	8.13	0.0	6.857	A
4 - Woolwich Road (W)	948.42	56.75	2316.88	0.409	949.68	0.7	2.635	A

**Main results: (09:15-09:30)**

Arm	Total Demand (Veh/hr)	Circulating flow (Veh/hr)	Capacity (Veh/hr)	RFC	Throughput (Veh/hr)	End queue (Veh)	Delay (s)	LOS
1 - Stone Lake Retail Park	6.02	828.13	966.36	0.006	6.03	0.0	3.747	A
2 - Woolwich Road (E)	901.92	73.09	2252.30	0.400	902.96	0.7	2.669	A
3 - York Terrace	6.78	970.78	644.07	0.011	6.80	0.0	5.650	A
4 - Woolwich Road (W)	794.26	47.49	2324.41	0.342	794.96	0.5	2.356	A

# 2016 Baseline, PM

## Data Errors and Warnings

*No errors or warnings*

## Analysis Set Details

ID	Network flow scaling factor (%)
A1	100.000

# Junction Network

## Junctions

Junction	Name	Junction Type	Junction Delay (s)	Junction LOS
1 - untitled	untitled	Standard Roundabout	4.86	A

## Junction Network Options

*[same as above]*

# Arms

## Arms

*[same as above]*

## Capacity Options

*[same as above]*

## Roundabout Geometry

*[same as above]*

## Slope / Intercept / Capacity

*[same as above]*

# Traffic Demand

## Demand Set Details

ID	Scenario name	Time Period name	Traffic profile type	Model start time (HH:mm)	Model finish time (HH:mm)	Time segment length (min)
D2	2016 Baseline	PM	ONE HOUR	17:00	18:30	15

Vehicle mix varies over turn	Vehicle mix varies over entry	Vehicle mix source	PCU Factor for a HV (PCU)
✓	✓	HV Percentages	2.00

## Demand overview (Traffic)

Arm	Linked arm	Use O-D data	Average Demand (Veh/hr)	Scaling Factor (%)
1 - Stone Lake Retail Park		✓	82.00	100.000
2 - Woolwich Road (E)		✓	1280.00	100.000
3 - York Terrace		✓	5.00	100.000
4 - Woolwich Road (W)		✓	1552.00	100.000

## Origin-Destination Data

### Demand (Veh/hr)

		To			
		1 - Stone Lake Retail Park	2 - Woolwich Road (E)	3 - York Terrace	4 - Woolwich Road (W)
From	1 - Stone Lake Retail Park	0.000	43.000	0.000	39.000
	2 - Woolwich Road (E)	32.000	24.000	6.000	1218.000
	3 - York Terrace	0.000	4.000	0.000	1.000
	4 - Woolwich Road (W)	51.000	1235.000	5.000	261.000

## Vehicle Mix

### Heavy Vehicle proportion

		To			
		1 - Stone Lake Retail Park	2 - Woolwich Road (E)	3 - York Terrace	4 - Woolwich Road (W)
From	1 - Stone Lake Retail Park	0	0	0	0
	2 - Woolwich Road (E)	0	4	0	5
	3 - York Terrace	0	0	0	0
	4 - Woolwich Road (W)	0	7	0	1

## Results

### Results Summary for whole modelled period

Arm	Max RFC	Max delay (s)	Max Queue (Veh)	Max LOS
1 - Stone Lake Retail Park	0.18	9.01	0.2	A
2 - Woolwich Road (E)	0.64	4.54	1.8	A
3 - York Terrace	0.02	14.05	0.0	B
4 - Woolwich Road (W)	0.70	4.88	2.3	A

## Main Results for each time segment

### Main results: (17:00-17:15)

Arm	Total Demand (Veh/hr)	Circulating flow (Veh/hr)	Capacity (Veh/hr)	RFC	Throughput (Veh/hr)	End queue (Veh)	Delay (s)	LOS
1 - Stone Lake Retail Park	61.73	1147.55	806.43	0.077	61.40	0.1	4.829	A
2 - Woolwich Road (E)	963.65	228.85	2281.17	0.422	960.74	0.7	2.721	A
3 - York Terrace	3.76	1181.33	564.63	0.007	3.74	0.0	6.417	A
4 - Woolwich Road (W)	1168.43	45.02	2461.19	0.475	1164.84	0.9	2.768	A

### Main results: (17:15-17:30)

Arm	Total Demand (Veh/hr)	Circulating flow (Veh/hr)	Capacity (Veh/hr)	RFC	Throughput (Veh/hr)	End queue (Veh)	Delay (s)	LOS
1 - Stone Lake Retail Park	73.72	1372.92	673.31	0.109	73.56	0.1	6.001	A
2 - Woolwich Road (E)	1150.69	273.83	2248.28	0.512	1149.44	1.0	3.274	A
3 - York Terrace	4.49	1413.40	437.17	0.010	4.48	0.0	8.320	A
4 - Woolwich Road (W)	1395.22	53.87	2454.55	0.568	1393.59	1.3	3.389	A

### Main results: (17:30-17:45)

Arm	Total Demand (Veh/hr)	Circulating flow (Veh/hr)	Capacity (Veh/hr)	RFC	Throughput (Veh/hr)	End queue (Veh)	Delay (s)	LOS
1 - Stone Lake Retail Park	90.28	1679.60	492.17	0.183	89.88	0.2	8.939	A
2 - Woolwich Road (E)	1409.30	334.95	2203.59	0.640	1406.47	1.8	4.500	A
3 - York Terrace	5.51	1729.34	263.64	0.021	5.46	0.0	13.942	B
4 - Woolwich Road (W)	1708.79	65.90	2445.53	0.699	1704.90	2.3	4.836	A

### Main results: (17:45-18:00)

Arm	Total Demand (Veh/hr)	Circulating flow (Veh/hr)	Capacity (Veh/hr)	RFC	Throughput (Veh/hr)	End queue (Veh)	Delay (s)	LOS
1 - Stone Lake Retail Park	90.28	1683.37	489.94	0.184	90.27	0.2	9.007	A
2 - Woolwich Road (E)	1409.30	335.79	2202.97	0.640	1409.25	1.8	4.535	A
3 - York Terrace	5.51	1732.94	261.67	0.021	5.50	0.0	14.052	B
4 - Woolwich Road (W)	1708.79	66.06	2445.41	0.699	1708.71	2.3	4.884	A

### Main results: (18:00-18:15)

Arm	Total Demand (Veh/hr)	Circulating flow (Veh/hr)	Capacity (Veh/hr)	RFC	Throughput (Veh/hr)	End queue (Veh)	Delay (s)	LOS
1 - Stone Lake Retail Park	73.72	1378.39	670.09	0.110	74.12	0.1	6.043	A
2 - Woolwich Road (E)	1150.69	275.05	2247.39	0.512	1153.52	1.1	3.301	A
3 - York Terrace	4.49	1418.65	434.29	0.010	4.54	0.0	8.379	A
4 - Woolwich Road (W)	1395.22	54.10	2454.39	0.568	1399.10	1.3	3.425	A

### Main results: (18:15-18:30)

Arm	Total Demand (Veh/hr)	Circulating flow (Veh/hr)	Capacity (Veh/hr)	RFC	Throughput (Veh/hr)	End queue (Veh)	Delay (s)	LOS
1 - Stone Lake Retail Park	61.73	1152.78	803.35	0.077	61.90	0.1	4.857	A
2 - Woolwich Road (E)	963.65	229.98	2280.34	0.423	964.93	0.7	2.741	A
3 - York Terrace	3.76	1186.63	561.72	0.007	3.78	0.0	6.451	A
4 - Woolwich Road (W)	1168.43	45.24	2461.03	0.475	1170.11	0.9	2.793	A



# Baseline Plus Proposed Development, AM

## Data Errors and Warnings

*No errors or warnings*

## Analysis Set Details

ID	Network flow scaling factor (%)
A1	100.000

# Junction Network

## Junctions

Junction	Name	Junction Type	Junction Delay (s)	Junction LOS
1 - untitled	untitled	Standard Roundabout	3.66	A

## Junction Network Options

*[same as above]*

# Arms

## Arms

*[same as above]*

## Capacity Options

*[same as above]*

## Roundabout Geometry

*[same as above]*

## Slope / Intercept / Capacity

*[same as above]*

# Traffic Demand

## Demand Set Details

ID	Scenario name	Time Period name	Traffic profile type	Model start time (HH:mm)	Model finish time (HH:mm)	Time segment length (min)
D3	Baseline Plus Proposed Development	AM	ONE HOUR	08:00	09:30	15

Vehicle mix varies over turn	Vehicle mix varies over entry	Vehicle mix source	PCU Factor for a HV (PCU)
✓	✓	HV Percentages	2.00

## Demand overview (Traffic)

Arm	Linked arm	Use O-D data	Average Demand (Veh/hr)	Scaling Factor (%)
1 - Stone Lake Retail Park		✓	8.00	100.000
2 - Woolwich Road (E)		✓	1193.00	100.000
3 - York Terrace		✓	9.00	100.000
4 - Woolwich Road (W)		✓	1099.00	100.000

## Origin-Destination Data

### Demand (Veh/hr)

		To			
		1 - Stone Lake Retail Park	2 - Woolwich Road (E)	3 - York Terrace	4 - Woolwich Road (W)
From	1 - Stone Lake Retail Park	0.000	2.000	0.000	6.000
	2 - Woolwich Road (E)	6.000	54.000	3.000	1130.000
	3 - York Terrace	0.000	3.000	0.000	6.000
	4 - Woolwich Road (W)	13.000	988.000	4.000	94.000

## Vehicle Mix

### Heavy Vehicle proportion

		To			
		1 - Stone Lake Retail Park	2 - Woolwich Road (E)	3 - York Terrace	4 - Woolwich Road (W)
From	1 - Stone Lake Retail Park	0	0	0	0
	2 - Woolwich Road (E)	0	19	0	11
	3 - York Terrace	0	0	0	0
	4 - Woolwich Road (W)	0	12	0	10

## Results

### Results Summary for whole modelled period

Arm	Max RFC	Max delay (s)	Max Queue (Veh)	Max LOS
1 - Stone Lake Retail Park	0.01	5.23	0.0	A
2 - Woolwich Road (E)	0.59	3.96	1.4	A
3 - York Terrace	0.03	9.71	0.0	A
4 - Woolwich Road (W)	0.52	3.28	1.1	A

## Main Results for each time segment

### Main results: (08:00-08:15)

Arm	Total Demand (Veh/hr)	Circulating flow (Veh/hr)	Capacity (Veh/hr)	RFC	Throughput (Veh/hr)	End queue (Veh)	Delay (s)	LOS
1 - Stone Lake Retail Park	6.02	858.20	947.63	0.006	6.00	0.0	3.822	A
2 - Woolwich Road (E)	898.15	78.08	2248.53	0.399	895.51	0.7	2.657	A
3 - York Terrace	6.78	968.33	645.53	0.011	6.73	0.0	5.635	A
4 - Woolwich Road (W)	827.39	47.28	2324.55	0.356	825.19	0.6	2.398	A

### Main results: (08:15-08:30)

Arm	Total Demand (Veh/hr)	Circulating flow (Veh/hr)	Capacity (Veh/hr)	RFC	Throughput (Veh/hr)	End queue (Veh)	Delay (s)	LOS
1 - Stone Lake Retail Park	7.19	1026.73	842.25	0.009	7.18	0.0	4.310	A
2 - Woolwich Road (E)	1072.48	93.42	2237.11	0.479	1071.47	0.9	3.085	A
3 - York Terrace	8.09	1158.60	533.93	0.015	8.07	0.0	6.845	A
4 - Woolwich Road (W)	987.98	56.58	2317.00	0.426	987.22	0.7	2.706	A

### Main results: (08:30-08:45)

Arm	Total Demand (Veh/hr)	Circulating flow (Veh/hr)	Capacity (Veh/hr)	RFC	Throughput (Veh/hr)	End queue (Veh)	Delay (s)	LOS
1 - Stone Lake Retail Park	8.81	1256.95	698.30	0.013	8.79	0.0	5.220	A
2 - Woolwich Road (E)	1313.52	114.37	2221.50	0.591	1311.45	1.4	3.947	A
3 - York Terrace	9.91	1418.12	381.72	0.026	9.86	0.0	9.679	A
4 - Woolwich Road (W)	1210.02	69.25	2306.69	0.525	1208.60	1.1	3.274	A

### Main results: (08:45-09:00)

Arm	Total Demand (Veh/hr)	Circulating flow (Veh/hr)	Capacity (Veh/hr)	RFC	Throughput (Veh/hr)	End queue (Veh)	Delay (s)	LOS
1 - Stone Lake Retail Park	8.81	1258.45	697.37	0.013	8.81	0.0	5.227	A
2 - Woolwich Road (E)	1313.52	114.50	2221.40	0.591	1313.49	1.4	3.965	A
3 - York Terrace	9.91	1420.28	380.45	0.026	9.91	0.0	9.714	A
4 - Woolwich Road (W)	1210.02	69.36	2306.60	0.525	1210.01	1.1	3.282	A

### Main results: (09:00-09:15)

Arm	Total Demand (Veh/hr)	Circulating flow (Veh/hr)	Capacity (Veh/hr)	RFC	Throughput (Veh/hr)	End queue (Veh)	Delay (s)	LOS
1 - Stone Lake Retail Park	7.19	1029.03	840.82	0.009	7.21	0.0	4.320	A
2 - Woolwich Road (E)	1072.48	93.63	2236.95	0.479	1074.53	0.9	3.104	A
3 - York Terrace	8.09	1161.86	532.02	0.015	8.13	0.0	6.871	A
4 - Woolwich Road (W)	987.98	56.75	2316.85	0.426	989.39	0.7	2.714	A

**Main results: (09:15-09:30)**

Arm	Total Demand (Veh/hr)	Circulating flow (Veh/hr)	Capacity (Veh/hr)	RFC	Throughput (Veh/hr)	End queue (Veh)	Delay (s)	LOS
1 - Stone Lake Retail Park	6.02	861.32	945.68	0.006	6.03	0.0	3.833	A
2 - Woolwich Road (E)	898.15	78.37	2248.31	0.399	899.19	0.7	2.669	A
3 - York Terrace	6.78	972.28	643.21	0.011	6.80	0.0	5.658	A
4 - Woolwich Road (W)	827.39	47.49	2324.39	0.356	828.16	0.6	2.408	A

# Baseline Plus Proposed Development, PM

## Data Errors and Warnings

*No errors or warnings*

## Analysis Set Details

ID	Network flow scaling factor (%)
A1	100.000

# Junction Network

## Junctions

Junction	Name	Junction Type	Junction Delay (s)	Junction LOS
1 - untitled	untitled	Standard Roundabout	4.91	A

## Junction Network Options

*[same as above]*

# Arms

## Arms

*[same as above]*

## Capacity Options

*[same as above]*

## Roundabout Geometry

*[same as above]*

## Slope / Intercept / Capacity

*[same as above]*

# Traffic Demand

## Demand Set Details

ID	Scenario name	Time Period name	Traffic profile type	Model start time (HH:mm)	Model finish time (HH:mm)	Time segment length (min)
D4	Baseline Plus Proposed Development	PM	ONE HOUR	17:00	18:30	15

Vehicle mix varies over turn	Vehicle mix varies over entry	Vehicle mix source	PCU Factor for a HV (PCU)
✓	✓	HV Percentages	2.00

## Demand overview (Traffic)

Arm	Linked arm	Use O-D data	Average Demand (Veh/hr)	Scaling Factor (%)
1 - Stone Lake Retail Park		✓	82.00	100.000
2 - Woolwich Road (E)		✓	1304.00	100.000
3 - York Terrace		✓	5.00	100.000
4 - Woolwich Road (W)		✓	1548.00	100.000

## Origin-Destination Data

### Demand (Veh/hr)

		To			
		1 - Stone Lake Retail Park	2 - Woolwich Road (E)	3 - York Terrace	4 - Woolwich Road (W)
From	1 - Stone Lake Retail Park	0.000	43.000	0.000	39.000
	2 - Woolwich Road (E)	32.000	24.000	6.000	1242.000
	3 - York Terrace	0.000	4.000	0.000	1.000
	4 - Woolwich Road (W)	51.000	1232.000	5.000	260.000

## Vehicle Mix

### Heavy Vehicle proportion

		To			
		1 - Stone Lake Retail Park	2 - Woolwich Road (E)	3 - York Terrace	4 - Woolwich Road (W)
From	1 - Stone Lake Retail Park	0	0	0	0
	2 - Woolwich Road (E)	0	4	0	5
	3 - York Terrace	0	0	0	0
	4 - Woolwich Road (W)	0	7	0	1

## Results

### Results Summary for whole modelled period

Arm	Max RFC	Max delay (s)	Max Queue (Veh)	Max LOS
1 - Stone Lake Retail Park	0.18	8.95	0.2	A
2 - Woolwich Road (E)	0.65	4.69	1.9	A
3 - York Terrace	0.02	14.87	0.0	B
4 - Woolwich Road (W)	0.70	4.86	2.3	A

## Main Results for each time segment

### Main results: (17:00-17:15)

Arm	Total Demand (Veh/hr)	Circulating flow (Veh/hr)	Capacity (Veh/hr)	RFC	Throughput (Veh/hr)	End queue (Veh)	Delay (s)	LOS
1 - Stone Lake Retail Park	61.73	1144.56	808.19	0.076	61.41	0.1	4.818	A
2 - Woolwich Road (E)	981.72	228.10	2281.66	0.430	978.71	0.8	2.757	A
3 - York Terrace	3.76	1198.55	555.07	0.007	3.74	0.0	6.529	A
4 - Woolwich Road (W)	1165.42	45.02	2461.17	0.474	1161.84	0.9	2.764	A

### Main results: (17:15-17:30)

Arm	Total Demand (Veh/hr)	Circulating flow (Veh/hr)	Capacity (Veh/hr)	RFC	Throughput (Veh/hr)	End queue (Veh)	Delay (s)	LOS
1 - Stone Lake Retail Park	73.72	1369.34	675.42	0.109	73.56	0.1	5.980	A
2 - Woolwich Road (E)	1172.27	272.94	2248.87	0.521	1170.95	1.1	3.335	A
3 - York Terrace	4.49	1434.01	425.73	0.011	4.48	0.0	8.545	A
4 - Woolwich Road (W)	1391.62	53.87	2454.53	0.567	1390.00	1.3	3.378	A

### Main results: (17:30-17:45)

Arm	Total Demand (Veh/hr)	Circulating flow (Veh/hr)	Capacity (Veh/hr)	RFC	Throughput (Veh/hr)	End queue (Veh)	Delay (s)	LOS
1 - Stone Lake Retail Park	90.28	1675.23	494.74	0.182	89.89	0.2	8.882	A
2 - Woolwich Road (E)	1435.73	333.86	2204.32	0.651	1432.69	1.8	4.646	A
3 - York Terrace	5.51	1754.46	249.70	0.022	5.46	0.0	14.740	B
4 - Woolwich Road (W)	1704.38	65.89	2445.51	0.697	1700.53	2.3	4.807	A

### Main results: (17:45-18:00)

Arm	Total Demand (Veh/hr)	Circulating flow (Veh/hr)	Capacity (Veh/hr)	RFC	Throughput (Veh/hr)	End queue (Veh)	Delay (s)	LOS
1 - Stone Lake Retail Park	90.28	1678.97	492.53	0.183	90.27	0.2	8.949	A
2 - Woolwich Road (E)	1435.73	334.69	2203.72	0.652	1435.67	1.9	4.687	A
3 - York Terrace	5.51	1758.26	247.62	0.022	5.50	0.0	14.868	B
4 - Woolwich Road (W)	1704.38	66.06	2445.39	0.697	1704.30	2.3	4.855	A

### Main results: (18:00-18:15)

Arm	Total Demand (Veh/hr)	Circulating flow (Veh/hr)	Capacity (Veh/hr)	RFC	Throughput (Veh/hr)	End queue (Veh)	Delay (s)	LOS
1 - Stone Lake Retail Park	73.72	1374.75	672.23	0.110	74.11	0.1	6.024	A
2 - Woolwich Road (E)	1172.27	274.13	2248.00	0.521	1175.30	1.1	3.367	A
3 - York Terrace	4.49	1439.52	422.71	0.011	4.54	0.0	8.611	A
4 - Woolwich Road (W)	1391.62	54.11	2454.36	0.567	1395.46	1.3	3.411	A

**Main results: (18:15-18:30)**

Arm	Total Demand (Veh/hr)	Circulating flow (Veh/hr)	Capacity (Veh/hr)	RFC	Throughput (Veh/hr)	End queue (Veh)	Delay (s)	LOS
1 - Stone Lake Retail Park	61.73	1149.75	805.13	0.077	61.90	0.1	4.844	A
2 - Woolwich Road (E)	981.72	229.23	2280.83	0.430	983.07	0.8	2.776	A
3 - York Terrace	3.76	1204.01	552.08	0.007	3.78	0.0	6.565	A
4 - Woolwich Road (W)	1165.42	45.24	2461.01	0.474	1167.08	0.9	2.785	A

# Baseline Plus Other Cumulative Developments, AM

## Data Errors and Warnings

*No errors or warnings*

## Analysis Set Details

ID	Network flow scaling factor (%)
A1	100.000

# Junction Network

## Junctions

Junction	Name	Junction Type	Junction Delay (s)	Junction LOS
1 - untitled	untitled	Standard Roundabout	3.99	A

## Junction Network Options

*[same as above]*

# Arms

## Arms

*[same as above]*

## Capacity Options

*[same as above]*

## Roundabout Geometry

*[same as above]*

## Slope / Intercept / Capacity

*[same as above]*

# Traffic Demand

## Demand Set Details

ID	Scenario name	Time Period name	Traffic profile type	Model start time (HH:mm)	Model finish time (HH:mm)	Time segment length (min)
D5	Baseline Plus Other Cumulative Developments	AM	ONE HOUR	08:00	09:30	15

Vehicle mix varies over turn	Vehicle mix varies over entry	Vehicle mix source	PCU Factor for a HV (PCU)
✓	✓	HV Percentages	2.00

## Demand overview (Traffic)

Arm	Linked arm	Use O-D data	Average Demand (Veh/hr)	Scaling Factor (%)
1 - Stone Lake Retail Park		✓	8.00	100.000
2 - Woolwich Road (E)		✓	1279.00	100.000
3 - York Terrace		✓	9.00	100.000
4 - Woolwich Road (W)		✓	1202.00	100.000

## Origin-Destination Data

### Demand (Veh/hr)

		To			
		1 - Stone Lake Retail Park	2 - Woolwich Road (E)	3 - York Terrace	4 - Woolwich Road (W)
From	1 - Stone Lake Retail Park	0.000	2.000	0.000	6.000
	2 - Woolwich Road (E)	6.000	54.000	3.000	1216.000
	3 - York Terrace	0.000	3.000	0.000	6.000
	4 - Woolwich Road (W)	13.000	1094.000	4.000	91.000

## Vehicle Mix

### Heavy Vehicle proportion

		To			
		1 - Stone Lake Retail Park	2 - Woolwich Road (E)	3 - York Terrace	4 - Woolwich Road (W)
From	1 - Stone Lake Retail Park	0	0	0	0
	2 - Woolwich Road (E)	0	19	0	10
	3 - York Terrace	0	0	0	0
	4 - Woolwich Road (W)	0	11	0	10

## Results

### Results Summary for whole modelled period

Arm	Max RFC	Max delay (s)	Max Queue (Veh)	Max LOS
1 - Stone Lake Retail Park	0.01	5.76	0.0	A
2 - Woolwich Road (E)	0.63	4.31	1.7	A
3 - York Terrace	0.03	11.11	0.0	B
4 - Woolwich Road (W)	0.57	3.59	1.3	A

## Main Results for each time segment

### Main results: (08:00-08:15)

Arm	Total Demand (Veh/hr)	Circulating flow (Veh/hr)	Capacity (Veh/hr)	RFC	Throughput (Veh/hr)	End queue (Veh)	Delay (s)	LOS
1 - Stone Lake Retail Park	6.02	935.44	903.94	0.007	6.00	0.0	4.009	A
2 - Woolwich Road (E)	962.89	75.82	2269.99	0.424	959.96	0.7	2.742	A
3 - York Terrace	6.78	1030.53	613.90	0.011	6.73	0.0	5.928	A
4 - Woolwich Road (W)	904.93	47.28	2342.90	0.386	902.42	0.6	2.495	A

### Main results: (08:15-08:30)

Arm	Total Demand (Veh/hr)	Circulating flow (Veh/hr)	Capacity (Veh/hr)	RFC	Throughput (Veh/hr)	End queue (Veh)	Delay (s)	LOS
1 - Stone Lake Retail Park	7.19	1119.16	789.96	0.009	7.18	0.0	4.598	A
2 - Woolwich Road (E)	1149.79	90.72	2258.81	0.509	1148.60	1.0	3.240	A
3 - York Terrace	8.09	1233.03	496.09	0.016	8.07	0.0	7.376	A
4 - Woolwich Road (W)	1080.57	56.57	2335.28	0.463	1079.65	0.9	2.866	A

### Main results: (08:30-08:45)

Arm	Total Demand (Veh/hr)	Circulating flow (Veh/hr)	Capacity (Veh/hr)	RFC	Throughput (Veh/hr)	End queue (Veh)	Delay (s)	LOS
1 - Stone Lake Retail Park	8.81	1369.95	634.38	0.014	8.79	0.0	5.754	A
2 - Woolwich Road (E)	1408.20	111.05	2243.54	0.628	1405.66	1.7	4.284	A
3 - York Terrace	9.91	1509.01	335.53	0.030	9.85	0.0	11.053	B
4 - Woolwich Road (W)	1323.42	69.23	2324.91	0.569	1321.61	1.3	3.582	A

### Main results: (08:45-09:00)

Arm	Total Demand (Veh/hr)	Circulating flow (Veh/hr)	Capacity (Veh/hr)	RFC	Throughput (Veh/hr)	End queue (Veh)	Delay (s)	LOS
1 - Stone Lake Retail Park	8.81	1371.84	633.20	0.014	8.81	0.0	5.764	A
2 - Woolwich Road (E)	1408.20	111.20	2243.42	0.628	1408.16	1.7	4.309	A
3 - York Terrace	9.91	1511.65	333.99	0.030	9.91	0.0	11.107	B
4 - Woolwich Road (W)	1323.42	69.36	2324.80	0.569	1323.40	1.3	3.594	A

### Main results: (09:00-09:15)

Arm	Total Demand (Veh/hr)	Circulating flow (Veh/hr)	Capacity (Veh/hr)	RFC	Throughput (Veh/hr)	End queue (Veh)	Delay (s)	LOS
1 - Stone Lake Retail Park	7.19	1122.03	788.18	0.009	7.21	0.0	4.609	A
2 - Woolwich Road (E)	1149.79	90.95	2258.63	0.509	1152.31	1.0	3.263	A
3 - York Terrace	8.09	1236.96	493.80	0.016	8.15	0.0	7.415	A
4 - Woolwich Road (W)	1080.57	56.77	2335.12	0.463	1082.37	0.9	2.879	A

**Main results: (09:15-09:30)**

Arm	Total Demand (Veh/hr)	Circulating flow (Veh/hr)	Capacity (Veh/hr)	RFC	Throughput (Veh/hr)	End queue (Veh)	Delay (s)	LOS
1 - Stone Lake Retail Park	6.02	939.04	901.70	0.007	6.03	0.0	4.020	A
2 - Woolwich Road (E)	962.89	76.12	2269.77	0.424	964.11	0.7	2.759	A
3 - York Terrace	6.78	1034.95	611.33	0.011	6.80	0.0	5.956	A
4 - Woolwich Road (W)	904.93	47.49	2342.72	0.386	905.86	0.6	2.506	A

# Baseline Plus Other Cumulative Developments, PM

## Data Errors and Warnings

*No errors or warnings*

## Analysis Set Details

ID	Network flow scaling factor (%)
A1	100.000

# Junction Network

## Junctions

Junction	Name	Junction Type	Junction Delay (s)	Junction LOS
1 - untitled	untitled	Standard Roundabout	6.23	A

## Junction Network Options

*[same as above]*

# Arms

## Arms

*[same as above]*

## Capacity Options

*[same as above]*

## Roundabout Geometry

*[same as above]*

## Slope / Intercept / Capacity

*[same as above]*

# Traffic Demand

## Demand Set Details

ID	Scenario name	Time Period name	Traffic profile type	Model start time (HH:mm)	Model finish time (HH:mm)	Time segment length (min)
D6	Baseline Plus Other Cumulative Developments	PM	ONE HOUR	17:00	18:30	15

Vehicle mix varies over turn	Vehicle mix varies over entry	Vehicle mix source	PCU Factor for a HV (PCU)
✓	✓	HV Percentages	2.00

## Demand overview (Traffic)

Arm	Linked arm	Use O-D data	Average Demand (Veh/hr)	Scaling Factor (%)
1 - Stone Lake Retail Park		✓	82.00	100.000
2 - Woolwich Road (E)		✓	1471.00	100.000
3 - York Terrace		✓	5.00	100.000
4 - Woolwich Road (W)		✓	1670.00	100.000

## Origin-Destination Data

### Demand (Veh/hr)

		To			
		1 - Stone Lake Retail Park	2 - Woolwich Road (E)	3 - York Terrace	4 - Woolwich Road (W)
From	1 - Stone Lake Retail Park	0.000	43.000	0.000	39.000
	2 - Woolwich Road (E)	32.000	24.000	6.000	1409.000
	3 - York Terrace	0.000	4.000	0.000	1.000
	4 - Woolwich Road (W)	51.000	1347.000	5.000	267.000

## Vehicle Mix

### Heavy Vehicle proportion

		To			
		1 - Stone Lake Retail Park	2 - Woolwich Road (E)	3 - York Terrace	4 - Woolwich Road (W)
From	1 - Stone Lake Retail Park	0	0	0	0
	2 - Woolwich Road (E)	0	4	0	5
	3 - York Terrace	0	0	0	0
	4 - Woolwich Road (W)	0	7	0	1

## Results

### Results Summary for whole modelled period

Arm	Max RFC	Max delay (s)	Max Queue (Veh)	Max LOS
1 - Stone Lake Retail Park	0.22	11.17	0.3	B
2 - Woolwich Road (E)	0.74	6.22	2.8	A
3 - York Terrace	0.04	26.43	0.0	D
4 - Woolwich Road (W)	0.75	5.94	3.0	A

## Main Results for each time segment

### Main results: (17:00-17:15)

Arm	Total Demand (Veh/hr)	Circulating flow (Veh/hr)	Capacity (Veh/hr)	RFC	Throughput (Veh/hr)	End queue (Veh)	Delay (s)	LOS
1 - Stone Lake Retail Park	61.73	1235.84	753.89	0.082	61.38	0.1	5.196	A
2 - Woolwich Road (E)	1107.44	233.29	2277.44	0.486	1103.68	0.9	3.056	A
3 - York Terrace	3.76	1328.72	483.07	0.008	3.73	0.0	7.509	A
4 - Woolwich Road (W)	1257.26	45.00	2459.63	0.511	1253.11	1.0	2.974	A

### Main results: (17:15-17:30)

Arm	Total Demand (Veh/hr)	Circulating flow (Veh/hr)	Capacity (Veh/hr)	RFC	Throughput (Veh/hr)	End queue (Veh)	Delay (s)	LOS
1 - Stone Lake Retail Park	73.72	1478.55	610.45	0.121	73.53	0.1	6.703	A
2 - Woolwich Road (E)	1322.39	279.15	2243.91	0.589	1320.47	1.4	3.891	A
3 - York Terrace	4.49	1589.76	339.58	0.013	4.47	0.0	10.743	B
4 - Woolwich Road (W)	1501.30	53.85	2453.00	0.612	1499.21	1.6	3.766	A

### Main results: (17:30-17:45)

Arm	Total Demand (Veh/hr)	Circulating flow (Veh/hr)	Capacity (Veh/hr)	RFC	Throughput (Veh/hr)	End queue (Veh)	Delay (s)	LOS
1 - Stone Lake Retail Park	90.28	1807.78	415.87	0.217	89.74	0.3	11.019	B
2 - Woolwich Road (E)	1619.59	341.24	2198.52	0.737	1614.36	2.7	6.108	A
3 - York Terrace	5.51	1943.54	145.10	0.038	5.40	0.0	25.752	D
4 - Woolwich Road (W)	1838.70	65.78	2444.05	0.752	1833.10	3.0	5.839	A

### Main results: (17:45-18:00)

Arm	Total Demand (Veh/hr)	Circulating flow (Veh/hr)	Capacity (Veh/hr)	RFC	Throughput (Veh/hr)	End queue (Veh)	Delay (s)	LOS
1 - Stone Lake Retail Park	90.28	1813.23	412.66	0.219	90.27	0.3	11.166	B
2 - Woolwich Road (E)	1619.59	342.38	2197.68	0.737	1619.45	2.8	6.221	A
3 - York Terrace	5.51	1949.73	141.70	0.039	5.50	0.0	26.429	D
4 - Woolwich Road (W)	1838.70	66.05	2443.85	0.752	1838.55	3.0	5.943	A

### Main results: (18:00-18:15)

Arm	Total Demand (Veh/hr)	Circulating flow (Veh/hr)	Capacity (Veh/hr)	RFC	Throughput (Veh/hr)	End queue (Veh)	Delay (s)	LOS
1 - Stone Lake Retail Park	73.72	1486.23	605.91	0.122	74.27	0.1	6.777	A
2 - Woolwich Road (E)	1322.39	280.76	2242.74	0.590	1327.65	1.5	3.955	A
3 - York Terrace	4.49	1598.48	334.78	0.013	4.60	0.0	10.907	B
4 - Woolwich Road (W)	1501.30	54.22	2452.72	0.612	1506.91	1.6	3.830	A

**Main results: (18:15-18:30)**

Arm	Total Demand (Veh/hr)	Circulating flow (Veh/hr)	Capacity (Veh/hr)	RFC	Throughput (Veh/hr)	End queue (Veh)	Delay (s)	LOS
1 - Stone Lake Retail Park	61.73	1242.10	750.18	0.082	61.93	0.1	5.233	A
2 - Woolwich Road (E)	1107.44	234.59	2276.50	0.486	1109.43	1.0	3.091	A
3 - York Terrace	3.76	1335.73	479.22	0.008	3.79	0.0	7.574	A
4 - Woolwich Road (W)	1257.26	45.27	2459.43	0.511	1259.43	1.1	3.004	A

# Cumulative Development Scenario, AM

## Data Errors and Warnings

*No errors or warnings*

## Analysis Set Details

ID	Network flow scaling factor (%)
A1	100.000

# Junction Network

## Junctions

Junction	Name	Junction Type	Junction Delay (s)	Junction LOS
1 - untitled	untitled	Standard Roundabout	4.03	A

## Junction Network Options

*[same as above]*

# Arms

## Arms

*[same as above]*

## Capacity Options

*[same as above]*

## Roundabout Geometry

*[same as above]*

## Slope / Intercept / Capacity

*[same as above]*

# Traffic Demand

## Demand Set Details

ID	Scenario name	Time Period name	Traffic profile type	Model start time (HH:mm)	Model finish time (HH:mm)	Time segment length (min)
D7	Cumulative Development Scenario	AM	ONE HOUR	08:00	09:30	15

Vehicle mix varies over turn	Vehicle mix varies over entry	Vehicle mix source	PCU Factor for a HV (PCU)
✓	✓	HV Percentages	2.00

## Demand overview (Traffic)

Arm	Linked arm	Use O-D data	Average Demand (Veh/hr)	Scaling Factor (%)
1 - Stone Lake Retail Park		✓	8.00	100.000
2 - Woolwich Road (E)		✓	1274.00	100.000
3 - York Terrace		✓	9.00	100.000
4 - Woolwich Road (W)		✓	1245.00	100.000

## Origin-Destination Data

### Demand (Veh/hr)

		To			
		1 - Stone Lake Retail Park	2 - Woolwich Road (E)	3 - York Terrace	4 - Woolwich Road (W)
From	1 - Stone Lake Retail Park	0.000	2.000	0.000	6.000
	2 - Woolwich Road (E)	6.000	54.000	3.000	1211.000
	3 - York Terrace	0.000	3.000	0.000	6.000
	4 - Woolwich Road (W)	13.000	1130.000	4.000	98.000

## Vehicle Mix

### Heavy Vehicle proportion

		To			
		1 - Stone Lake Retail Park	2 - Woolwich Road (E)	3 - York Terrace	4 - Woolwich Road (W)
From	1 - Stone Lake Retail Park	0	0	0	0
	2 - Woolwich Road (E)	0	19	0	10
	3 - York Terrace	0	0	0	0
	4 - Woolwich Road (W)	0	10	0	9

## Results

### Results Summary for whole modelled period

Arm	Max RFC	Max delay (s)	Max Queue (Veh)	Max LOS
1 - Stone Lake Retail Park	0.01	5.97	0.0	A
2 - Woolwich Road (E)	0.63	4.31	1.7	A
3 - York Terrace	0.03	11.13	0.0	B
4 - Woolwich Road (W)	0.58	3.69	1.4	A

## Main Results for each time segment

### Main results: (08:00-08:15)

Arm	Total Demand (Veh/hr)	Circulating flow (Veh/hr)	Capacity (Veh/hr)	RFC	Throughput (Veh/hr)	End queue (Veh)	Delay (s)	LOS
1 - Stone Lake Retail Park	6.02	967.70	889.13	0.007	6.00	0.0	4.076	A
2 - Woolwich Road (E)	959.13	81.07	2266.50	0.423	956.21	0.7	2.742	A
3 - York Terrace	6.78	1032.03	613.42	0.011	6.73	0.0	5.933	A
4 - Woolwich Road (W)	937.30	47.28	2363.90	0.397	934.68	0.7	2.515	A

### Main results: (08:15-08:30)

Arm	Total Demand (Veh/hr)	Circulating flow (Veh/hr)	Capacity (Veh/hr)	RFC	Throughput (Veh/hr)	End queue (Veh)	Delay (s)	LOS
1 - Stone Lake Retail Park	7.19	1157.75	772.25	0.009	7.18	0.0	4.705	A
2 - Woolwich Road (E)	1145.30	97.00	2254.63	0.508	1144.12	1.0	3.239	A
3 - York Terrace	8.09	1234.83	495.51	0.016	8.07	0.0	7.384	A
4 - Woolwich Road (W)	1119.23	56.57	2356.21	0.475	1118.25	0.9	2.905	A

### Main results: (08:30-08:45)

Arm	Total Demand (Veh/hr)	Circulating flow (Veh/hr)	Capacity (Veh/hr)	RFC	Throughput (Veh/hr)	End queue (Veh)	Delay (s)	LOS
1 - Stone Lake Retail Park	8.81	1417.13	612.74	0.014	8.79	0.0	5.960	A
2 - Woolwich Road (E)	1402.70	118.73	2238.43	0.627	1400.17	1.7	4.282	A
3 - York Terrace	9.91	1511.21	334.82	0.030	9.85	0.0	11.077	B
4 - Woolwich Road (W)	1370.77	69.23	2345.75	0.584	1368.79	1.4	3.677	A

### Main results: (08:45-09:00)

Arm	Total Demand (Veh/hr)	Circulating flow (Veh/hr)	Capacity (Veh/hr)	RFC	Throughput (Veh/hr)	End queue (Veh)	Delay (s)	LOS
1 - Stone Lake Retail Park	8.81	1419.18	611.48	0.014	8.81	0.0	5.972	A
2 - Woolwich Road (E)	1402.70	118.91	2238.30	0.627	1402.66	1.7	4.307	A
3 - York Terrace	9.91	1513.86	333.28	0.030	9.91	0.0	11.132	B
4 - Woolwich Road (W)	1370.77	69.36	2345.64	0.584	1370.74	1.4	3.691	A

### Main results: (09:00-09:15)

Arm	Total Demand (Veh/hr)	Circulating flow (Veh/hr)	Capacity (Veh/hr)	RFC	Throughput (Veh/hr)	End queue (Veh)	Delay (s)	LOS
1 - Stone Lake Retail Park	7.19	1160.84	770.35	0.009	7.21	0.0	4.717	A
2 - Woolwich Road (E)	1145.30	97.27	2254.43	0.508	1147.81	1.0	3.262	A
3 - York Terrace	8.09	1238.77	493.22	0.016	8.15	0.0	7.421	A
4 - Woolwich Road (W)	1119.23	56.77	2356.05	0.475	1121.18	0.9	2.921	A

**Main results: (09:15-09:30)**

Arm	Total Demand (Veh/hr)	Circulating flow (Veh/hr)	Capacity (Veh/hr)	RFC	Throughput (Veh/hr)	End queue (Veh)	Delay (s)	LOS
1 - Stone Lake Retail Park	6.02	971.47	886.81	0.007	6.03	0.0	4.087	A
2 - Woolwich Road (E)	959.13	81.40	2266.26	0.423	960.34	0.7	2.760	A
3 - York Terrace	6.78	1036.46	610.85	0.011	6.80	0.0	5.961	A
4 - Woolwich Road (W)	937.30	47.49	2363.72	0.397	938.30	0.7	2.526	A

# Cumulative Development Scenario, PM

## Data Errors and Warnings

*No errors or warnings*

## Analysis Set Details

ID	Network flow scaling factor (%)
A1	100.000

# Junction Network

## Junctions

Junction	Name	Junction Type	Junction Delay (s)	Junction LOS
1 - untitled	untitled	Standard Roundabout	6.23	A

## Junction Network Options

*[same as above]*

# Arms

## Arms

*[same as above]*

## Capacity Options

*[same as above]*

## Roundabout Geometry

*[same as above]*

## Slope / Intercept / Capacity

*[same as above]*

# Traffic Demand

## Demand Set Details

ID	Scenario name	Time Period name	Traffic profile type	Model start time (HH:mm)	Model finish time (HH:mm)	Time segment length (min)
D8	Cumulative Development Scenario	PM	ONE HOUR	17:00	18:30	15

Vehicle mix varies over turn	Vehicle mix varies over entry	Vehicle mix source	PCU Factor for a HV (PCU)
✓	✓	HV Percentages	2.00

## Demand overview (Traffic)

Arm	Linked arm	Use O-D data	Average Demand (Veh/hr)	Scaling Factor (%)
1 - Stone Lake Retail Park		✓	82.00	100.000
2 - Woolwich Road (E)		✓	1495.00	100.000
3 - York Terrace		✓	5.00	100.000
4 - Woolwich Road (W)		✓	1666.00	100.000

## Origin-Destination Data

### Demand (Veh/hr)

		To			
		1 - Stone Lake Retail Park	2 - Woolwich Road (E)	3 - York Terrace	4 - Woolwich Road (W)
From	1 - Stone Lake Retail Park	0.000	43.000	0.000	39.000
	2 - Woolwich Road (E)	32.000	24.000	6.000	1433.000
	3 - York Terrace	0.000	4.000	0.000	1.000
	4 - Woolwich Road (W)	51.000	1344.000	5.000	266.000

## Vehicle Mix

### Heavy Vehicle proportion

		To			
		1 - Stone Lake Retail Park	2 - Woolwich Road (E)	3 - York Terrace	4 - Woolwich Road (W)
From	1 - Stone Lake Retail Park	0	0	0	0
	2 - Woolwich Road (E)	0	4	0	4
	3 - York Terrace	0	0	0	0
	4 - Woolwich Road (W)	0	7	0	1

## Results

### Results Summary for whole modelled period

Arm	Max RFC	Max delay (s)	Max Queue (Veh)	Max LOS
1 - Stone Lake Retail Park	0.22	11.08	0.3	B
2 - Woolwich Road (E)	0.74	6.28	2.8	A
3 - York Terrace	0.04	27.59	0.0	D
4 - Woolwich Road (W)	0.75	5.90	3.0	A

## Main Results for each time segment

### Main results: (17:00-17:15)

Arm	Total Demand (Veh/hr)	Circulating flow (Veh/hr)	Capacity (Veh/hr)	RFC	Throughput (Veh/hr)	End queue (Veh)	Delay (s)	LOS
1 - Stone Lake Retail Park	61.73	1232.84	755.65	0.082	61.38	0.1	5.183	A
2 - Woolwich Road (E)	1125.52	232.54	2298.97	0.490	1121.71	1.0	3.048	A
3 - York Terrace	3.76	1345.99	479.16	0.008	3.73	0.0	7.571	A
4 - Woolwich Road (W)	1254.25	45.00	2459.60	0.510	1250.11	1.0	2.967	A

### Main results: (17:15-17:30)

Arm	Total Demand (Veh/hr)	Circulating flow (Veh/hr)	Capacity (Veh/hr)	RFC	Throughput (Veh/hr)	End queue (Veh)	Delay (s)	LOS
1 - Stone Lake Retail Park	73.72	1474.97	612.55	0.120	73.53	0.1	6.677	A
2 - Woolwich Road (E)	1343.98	278.26	2265.24	0.593	1342.01	1.4	3.892	A
3 - York Terrace	4.49	1610.39	334.91	0.013	4.47	0.0	10.894	B
4 - Woolwich Road (W)	1497.70	53.85	2452.97	0.611	1495.62	1.6	3.752	A

### Main results: (17:30-17:45)

Arm	Total Demand (Veh/hr)	Circulating flow (Veh/hr)	Capacity (Veh/hr)	RFC	Throughput (Veh/hr)	End queue (Veh)	Delay (s)	LOS
1 - Stone Lake Retail Park	90.28	1803.44	418.42	0.216	89.74	0.3	10.936	B
2 - Woolwich Road (E)	1646.03	340.16	2219.57	0.742	1640.62	2.8	6.160	A
3 - York Terrace	5.51	1968.70	139.44	0.039	5.40	0.0	26.858	D
4 - Woolwich Road (W)	1834.30	65.77	2444.03	0.751	1828.77	2.9	5.799	A

### Main results: (17:45-18:00)

Arm	Total Demand (Veh/hr)	Circulating flow (Veh/hr)	Capacity (Veh/hr)	RFC	Throughput (Veh/hr)	End queue (Veh)	Delay (s)	LOS
1 - Stone Lake Retail Park	90.28	1808.83	415.25	0.217	90.27	0.3	11.077	B
2 - Woolwich Road (E)	1646.03	341.28	2218.74	0.742	1645.88	2.8	6.280	A
3 - York Terrace	5.51	1975.04	135.98	0.040	5.50	0.0	27.588	D
4 - Woolwich Road (W)	1834.30	66.05	2443.82	0.751	1834.15	3.0	5.900	A

### Main results: (18:00-18:15)

Arm	Total Demand (Veh/hr)	Circulating flow (Veh/hr)	Capacity (Veh/hr)	RFC	Throughput (Veh/hr)	End queue (Veh)	Delay (s)	LOS
1 - Stone Lake Retail Park	73.72	1482.57	608.06	0.121	74.26	0.1	6.752	A
2 - Woolwich Road (E)	1343.98	279.84	2264.07	0.594	1349.42	1.5	3.958	A
3 - York Terrace	4.49	1619.32	330.04	0.014	4.60	0.0	11.065	B
4 - Woolwich Road (W)	1497.70	54.23	2452.69	0.611	1503.24	1.6	3.812	A

**Main results: (18:15-18:30)**

Arm	Total Demand (Veh/hr)	Circulating flow (Veh/hr)	Capacity (Veh/hr)	RFC	Throughput (Veh/hr)	End queue (Veh)	Delay (s)	LOS
1 - Stone Lake Retail Park	61.73	1239.08	751.97	0.082	61.93	0.1	5.220	A
2 - Woolwich Road (E)	1125.52	233.83	2298.03	0.490	1127.56	1.0	3.080	A
3 - York Terrace	3.76	1353.08	475.29	0.008	3.79	0.0	7.637	A
4 - Woolwich Road (W)	1254.25	45.27	2459.41	0.510	1256.40	1.0	2.997	A